

(No Model.)

# H. L. BOWDOIN. RUDDER LOCK.

No. 523,618.

Patented July 24, 1894.

FIG. 1.

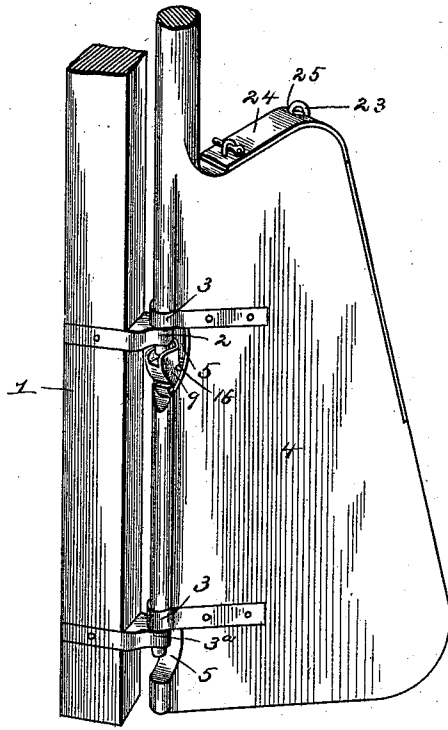

FIG. 2.

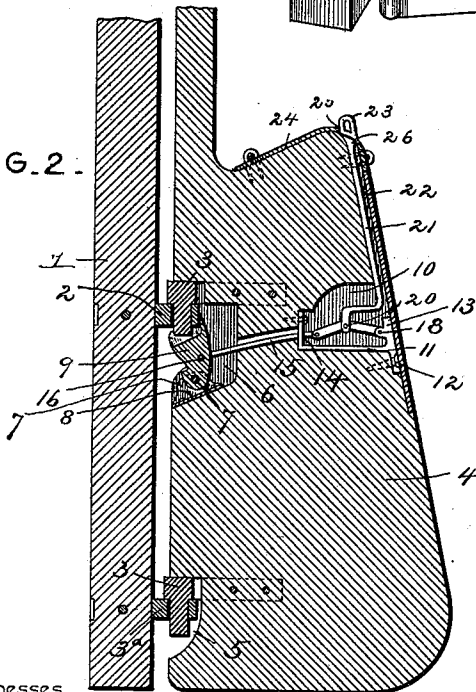
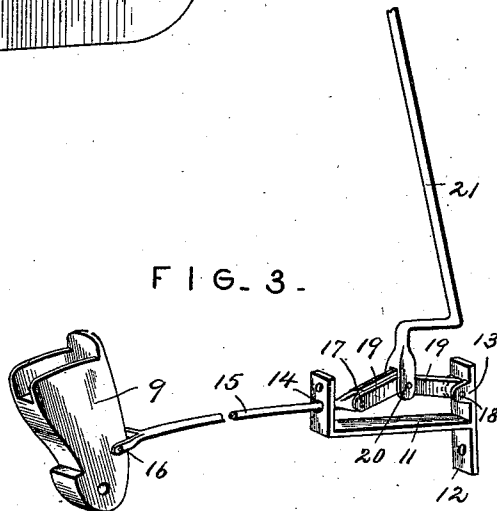

FIG. 3.



Inventor

*Harry L. Bowdoin.*

Witnesses

*Harry L. Amer.*

By his Attorneys.

*J. H. Tiggers,*

*C. A. Snow & Co.*

# UNITED STATES PATENT OFFICE.

HARRY L. BOWDOIN, OF WILMINGTON, NORTH CAROLINA.

## RUDDER-LOCK.

SPECIFICATION forming part of Letters Patent No. 523,618, dated July 24, 1894.

Application filed January 31, 1894. Serial No. 498,623. (No model.)

*To all whom it may concern:*

Be it known that I, HARRY L. BOWDOIN, a citizen of the United States, residing at Wilmington, in the county of New Hanover and State of North Carolina, have invented a new and useful Rudder-Lock, of which the following is a specification.

My invention has relation to boats and particular reference to certain improvements in the rudders thereof.

The objects of my invention are to provide for a cheap and simple construction of lock for securing rudders in their hinged positions on the stern-posts of vessels; to so construct the lock as to render the unshipping of the rudder possible without docking the vessel or employing a diver for the purpose of disconnecting the rudder, but to the contrary to enable such unshipping to be accomplished from the surface of the water or above the same; and finally to construct the lock so as to render the engagement of the rudder secure and safe.

Other objects and advantages of the invention will appear in the following description and the novel features thereof will be particularly pointed out in the claims.

Referring to the drawings:—Figure 1 is a perspective view of the stern-post and rudder of a vessel of any class. Fig. 2 is a vertical longitudinal sectional view of the same. Fig. 3 is a detail in perspective of the locking mechanism.

Like numerals of reference indicate like parts in all the figures of the drawings.

The stern-post 1 is provided with the usual braces to form eyes 2 and 3<sup>a</sup>, which project aft therefrom, and are designed to engage in a hinge-like manner with the depending pintles 3 located at the forward edge of the rudder 4, and extending from the upper sides of the usual recesses 5 provided for their reception, whereby the front edge of the latter is positioned in close proximity to the aforesaid stern-post 1.

A mortise, chamber or recess 6 is produced in the forward edge of the rudder immediately below the upper pintle, and located in the same is a pair of metal bearing-ears 7, the same being formed upon the metal securing-plate 8, secured in position in the bottom of

said recess. Between these ears there is pivoted a locking-block 9, the same having its upper end chambered so that when swung forward it receives the lower end of the upper pintle. The after edge of the rudder is likewise provided with a recess, mortise or chamber 10, and in the same is seated a substantially U-shaped metal frame, whose after end has a depending securing-flange 12. The after vertical portion of the metal frame 11 has formed on its inner side bearing ears 13, and the forward vertical portion has an opening 14 formed therein opposite the ears. Through this forward opening a connecting-rod 15 is passed, the front end of which is pivoted at 16 to the locking-block 9. Pivoted to the after end of this connecting-rod 15, as indicated at 17, and between the ears 13 as indicated at 18, is a pair of members or links 19 of an angle-joint, said members being pivotally connected at their inner ends at 20 to each other, and to the lower end of a bent operating-rod 21, which extends through a channel 22, with which the after edge of the rudder is provided, and terminates above the same in an eye 23.

The links, when swung downward in substantial alignment, form a positive lock to prevent any liability of the pivoted locking block 9 swinging inward and releasing the rudder; and the operating rod extends upward, and is supported by the links or members 19, whereby its weight serves to hold the latter in their locked positions.

The mortise in which the operating rod works is covered by a thin strip 24 of metal or wood. The operating rod projects far enough above the rudder to enable a hooked rod or similar tool to be inserted in the eye 23, whenever the lock is to be operated, and when not in operation the lock is held in place by the strip 24. The strip 24 is hinged at its after end to the rudder; its forward end is detachably secured by means of a staple and bolt; and the operating rod is provided below the eye 23 with a shoulder 26 of greater size than the opening 25 of the strip, to form a stop to prevent the operating rod from moving upward and releasing the rudder.

The operation of the invention is as follows: To unship the rudder remove the secur-

ing strip 24, insert a tool in the eye 23, the same serving to elevate or reciprocate vertically the operating-rod 22, and thus through the medium of the angle-joint and the connecting-rod 15 draw the locking-block inward or toward the after edge and from under the pintle of the rudder. No opposition then exists to an upward withdrawal of the rudder and its complete unshipping. To replace the rudder it is simply necessary to lower the pintles into the braces, and depress the lever, which forces the operating-rod 22 downward, and presses the angle-joint into substantial alignment and through the medium of the connecting-bar 15 pushing the locking-block 9 forward so that its upper chambered end takes under the upper pintle, and any upward motion of the rudder is resisted by the aforesaid locking-block coming into contact with the upper brace of the stern-post.

From the foregoing description in connection with the accompanying drawings, it will be seen that I have provided a very simple means for locking in operative position the rudders of vessels of any class whatever, which means is so constructed as to permit of a ready unshipping of the rudder when occasion requires, without the necessity of docking the vessel or diving below water to disengage the parts.

Various changes will suggest themselves as to the details of my invention, and I therefore do not limit the same to those particular details herein shown and described, but hold that I may vary the same to any degree and extent within the knowledge of the skilled mechanic.

It will be observed that my invention may be built in the rudder at the time of its manufacture, or may be applied at a slight cost to such rudders as are now in use, and it will be found adequate for vessels of any class whatever.

Having described my invention, what I claim is—

1. The combination with the stern post of a vessel and its eyes, of a rudder having pintles for removably engaging the eyes, a pivoted locking block arranged below one of the pintles and arranged to engage the under side of the receiving eye, the links pivoted together and connected with the rudder and the locking block, and means for swinging the

links upward and downward to operate the locking block, substantially as described. 55

2. The combination with the stern post of a vessel and its eyes, of a rudder having pintles for removably engaging the eyes, a locking block pivoted to the rudder and located below one of the pintles and engaging the under side of the adjacent eye, the pivoted links disposed substantially horizontally and connected with the rudder and the locking block and forming when lowered a brace to prevent inward movement of the pivoted locking block, and an upward extending operating rod connected with the links and resting upon the same and serving as a weight to hold the links downward, substantially as described. 60 65

3. The combination with the stern-post and eyes of a vessel, of a rudder and its depending pintles for removably engaging said eyes, a pivoted locking-block arranged below one of said eyes in the forward edge of said rudder, an operating-rod, connections between the same and the locking-block for causing a swinging movement of the block at a vertical movement of the rod, and means for causing said vertical movements of the rod, substantially as specified. 70 75 80

4. The combination with the stern-post and its eyes of a vessel, of a rudder having depending pintles in its forward edge for removably and loosely engaging the eyes, a metal bearing-plate arranged in the forward edge of the rudder below the uppermost pintle, a locking-block pivoted between the ears, and having its upper end recessed to receive the pintle, a metal U-frame arranged in an after recess in the rudder and having its forward end perforated, a connecting-bar passed through the perforation, and loosely connected at its front end with the locking-block, an angle-lever having its opposite ends connected to the rod, and to the frame, and the reciprocating operating rod arranged in a channel in the rudder and pivoted at its lower end at an intermediate point on the angle, substantially as specified. 85 90 95

In testimony that I claim the foregoing as my own I have hereto affixed my signature in the presence of two witnesses. 100

HARRY L. BOWDOIN.

Witnesses:

R. F. FOWLER,  
W. N. HARRISS.