



(11) **EP 2 065 649 A1**

(12) **EUROPEAN PATENT APPLICATION**

(43) Date of publication:
03.06.2009 Bulletin 2009/23

(51) Int Cl.:
F24C 7/08 (2006.01) F24C 15/36 (2006.01)

(21) Application number: **07023107.1**

(22) Date of filing: **29.11.2007**

(84) Designated Contracting States:
AT BE BG CH CY CZ DE DK EE ES FI FR GB GR HU IE IS IT LI LT LU LV MC MT NL PL PT RO SE SI SK TR

Designated Extension States:
AL BA HR MK RS

- **Nostro, Massimo**
47100 Forli (IT)
- **Chung, Ha Min**
61100 Pesaro (IT)
- **Viroli, Alex**
47100 Forli (IT)
- **Rigolle, Thibaut**
47100 Forli (IT)

(71) Applicant: **Electrolux Home Products Corporation N.V.**
1930 Zaventem (BE)

(74) Representative: **Hochmuth, Jürgen**
c/o AEG Hausgeräte GmbH
Group Intellectual Property
90327 Nürnberg (DE)

(72) Inventors:
• **Jeanneteau, Laurent**
60200 Compiègne (FR)

(54) **Cooking appliance, especially domestic cooking appliance**

(57) The invention relates to a cooking appliance (1), especially to a domestic cooking appliance, having a hob (2) with a front end (3). To improve the functionality and security of the cooking appliance, the invention is char-

acterized in that a front panel (4) is arranged at the front end (3) of the hob (2), wherein the front panel (4) has an upper edge (5) which is arranged above (h) the upper surface (6) of the hob (2).

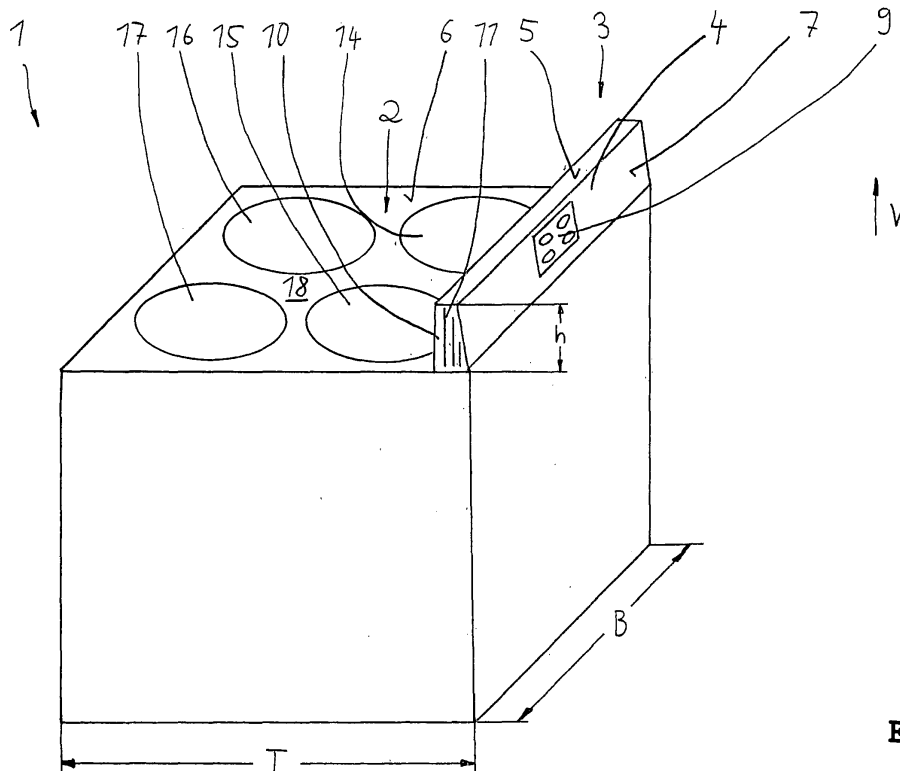

FIG 1

EP 2 065 649 A1

Description

[0001] The invention relates to a cooking appliance, especially to a domestic cooking appliance, having a hob with a front end.

[0002] Cooking appliances of this kind are well known in the art. Examples are shown in EP 0 570 670 A2 and in US 6,455,819 B1. For operating and controlling the cooking appliance switching and display elements are necessary which can be arranged on the hob surface or can be located in the front area of the hob. The mentioned solution according to the cited references employs switching and display elements which are located in the front area of the hob. In the case of EP 0 570 670 A1 the hob surface is slightly slanted in the front region where the switching and display elements are mounted.

[0003] For certain applications it is desired to equip the cooking appliance with security means to protect children. Those security means make sure that a child cannot grab a handle of a pot or of a pan and pull it down from the hob, what can cause scalds.

[0004] On the other side it is desired to use the surface of the hob as efficient as possible for cooking. The well-known design with integrated switching and display elements in the stove top contravenes to this demand, because the switching and display elements which are located on the stove top need a certain space.

[0005] Thus, it is desirable to design a cooking appliance in that way that a high level of security is ensured with regard to child protection and to allow a maximum use of the surface of the stove top for cooking.

[0006] Furthermore, if switching and display elements are arranged on the stove top it is possible that those elements are exposed to a quite high thermal strain. This can influence the lifetime of the elements.

[0007] Therefore, it is an object of the invention to suggest a cooking appliance, especially a domestic cooking appliance, which ensures a secure protection for children. Also, the surface of the stove top should be usable as much as possible for cooking. Finally, it should be made sure that the switching and display elements are protected against heat from the heating elements of the hob.

[0008] The solution of this object according to the invention is characterized in that a front panel is arranged at the front end of the hob, wherein the front panel has an upper edge which is arranged above the upper surface of the hob.

[0009] The front panel can extend substantial along the whole width of the hob.

[0010] The front panel preferably comprises a flat front surface. The plane of the front surface extends preferably with a small angel to the vertical direction. This angel can be between 10° and 30°.

[0011] The front panel can further comprise a flat rear surface facing the hob. The plane of the rear surface extends preferably in vertical direction.

[0012] The front panel has preferably a substantial tri-

angular form when viewed from the side.

[0013] The height of the upper edge above the upper surface of the hob is preferably between 15 % and 35 % of the depth of the hob.

5 **[0014]** At least one switching and/or display element can be arranged in the front surface of the front panel. At least one switching element can be a touch screen element and more specifically one of the TFT type (thin-film transistor).

10 **[0015]** The front panel can have side walls connecting the front surface and the rear surface of the front panel. The side walls can comprise at least one ventilation slot for exhaust air. At least one ventilation slot can be in fluidic connection with a bottom region of the front panel. 15 Preferably, at least one opening is arranged in the bottom region of the front panel. At least one fan can be integrated in the frame in which the heating elements are installed in the case of a hob, specifically induction heating elements. By operating the fans a flow of air can be produced. A preferred embodiment of the invention has openings in the frame by which air is sucked in. The air is then transported through the frame and blown out via the ventilation slots. If a design without fans is chosen, an air flow can be produced by natural convection.

20 **[0016]** The hob is preferably equipped with at least one heating element; the heating element can be an induction heating element.

[0017] The hob is preferably covered by a ceramic stove top. The ceramic stove top is preferably free from switching and/or display elements.

30 **[0018]** The suggested design makes sure that the cooking appliance is safely protected with respect to children which could draw down pots or pans from the hob. Due to the relatively high front panel it is not possible for a child to pull down a pot or pan from the hob.

35 **[0019]** Also, due to the integration of the switching and display elements into the front panel they are well protected against heat from the heating elements.

40 **[0020]** Finally, the surface of the hob can be kept free from any switching and display element. Thus, the available surface can be fully used for cooking purposes and consequently be equipped accordingly with heating elements.

45 **[0021]** In the drawings an embodiment of the invention is depicted.

FIG 1 shows a perspective view of a domestic cooking appliance with a hob with four heating elements and a front panel,

50 FIG 2 shows a perspective view of the hob of the cooking appliance, seen from the rear region of the appliance,

55 FIG 3 shows the same perspective view as FIG 2 but with dismantled hob and with the rear surface of the front panel being broken away,

- FIG 4 shows a side view of the hob of the appliance,
- FIG 5 shows a view from the rear side of the hob with the front panel and
- FIG 6 shows a perspective view of the right part of the front panel of the hob with the front surface of the front panel being broken away.

[0022] In the figures a domestic cooking appliance 1 and especially its hob 2 is depicted. The hob 2 has four heating elements 14, 15, 16 and 17. The surface 6 of the hob 2 is formed by a ceramic stove top 18. The stove top 18 is carried by a frame 19 which is depicted in FIG 3.

[0023] In general the hob 2 and thus the cooking appliance 1 have a width B and a depth T.

[0024] The hob 2 has a front end 3 which is facing the user during use of the appliance 1.

[0025] A front panel 4 is arranged at the front end 3 of the hob 2. The front panel 4 has an upper edge 5 which is arranged above the upper surface 6 of the hob 2. The height h of the upper edge 5 is shown and being substantial for establishing a protection for children so that they cannot pull down a pot or a pan from the hob 2. The height h of the front panel 4 is about 25 % of the depth T of the hob 2; a preferred range is between 15 % and 35 % of the depth T. In absolute figures the height h is normally between 90 mm and 135 mm; the depicted solution has a height h of about 113 mm.

[0026] Furthermore, the front panel 4 and more specifically its front surface 7 is big enough to receive switching and display elements 9 for controlling the appliance 1.

[0027] The front panel 4 has a substantial triangular shape when viewed from the side as can be seen in FIG 4. The front surface 7 and a rear surface 8 have a substantial flat shape. While the rear surface 8 extends in vertical direction V, the front surface 7 is arranged in such a way that its plane extends under a small angle α to the vertical direction V as can be seen in FIG 4. The angle α is about 20° in the depicted embodiment; the complementary angle β (see FIG 4) to the right angle is thus about 70°.

[0028] The front panel 4 has side walls 10 which can be best seen in FIG 2 and in FIG 6. The side walls 10 have ventilation slots 11 for the flow of air. As can be seen in FIG 6 the front panel 4 has an opening 13 in the bottom region 12 on both sides of the front panel 4. Thus, air 20 can flow along a path which is depicted in FIG 6. This allows an air exhaust from the hob 2 which improves the performance during cooking.

[0029] As can be seen in FIG 3, openings 21 can be machined into the bottom side of the frame 19. In the depicted embodiment two identical openings 21 are employed in the rear side of the frame 19. Behind the openings 21 fans (not depicted) can be mounted. When the fans are operated, an air flow takes place. As can be seen in FIG 3 air 22 is sucked in by the fans. The air is then transported through the frame 19 and can leave the

frame via the ventilation slots 11 (see air 23); reference is made to the air flow depicted in FIG 6. In the frame 19 heating elements 14, 15, 16, 17 are installed in the case of a hob, specifically induction heating elements. By operating the fans a flow of air can thus be produced. If a design without fans is chosen, an air flow can be produced by natural convection. By the specific guide of air the performance of the hob can be improved.

[0030] The front surface 7 offers sufficient space for mounting the necessary switching and/or display elements for operating and controlling the appliance. The space for placing the elements 9 allows a design which is chosen to meet the demands with respect to the aesthetical appearance of the appliance 1.

[0031] The front panel 4 can be made from the sheet metal from which the frame 19 is made, i. e. the front panel 4 can be one piece together with the frame 19. The production of the structure is economically possible by well-known methods of deforming, deep-drawing and punching of a sheet metal plate.

[0032] The invention allows by adding the front panel with the triangular section to the hob to implement all kinds of modern switches and displays, especially those with touch screens and using TFTs.

[0033] The high temperature area (stove top) is remote from the switches and displays so there is no influence from the heat of the stove top. The mounting of the switches and display elements into the front panel is quite easy.

[0034] The view to the display elements is improved due to the arrangement of the front surface of the front panel under the mentioned angle.

[0035] It is practically impossible that a pot or pan is drawn down from the hob by a child due to the mentioned height h of the front panel.

[0036] The exhaust of air is facilitated by the ventilation slots and the circulation of air can easily take place.

[0037] The front panel can also be provided as an add-on part which can be fixed i. e. by a snap connection to an existing hob.

[0038] An advantage of the panel according to the invention is that a glass element used for the panel is not used for the cooking area. As very often the standard cooking surface (ceramic or equivalent) is mainly dark red this limits the possible colours for the displays. Having a panel with a free surface, glass, polycarbonate or equivalents can be used; this allows the use of any colours for the display. I. e. any display can be employed which is trendy, like TFT displays or equivalents.

[0039] The cooking surface can be transparent but it needs a specific coating or enamelling to hide some components, but usually the cost is higher and the display can be in higher ambient temperature.

Reference Numerals

[0040]

1 Cooking Appliance

2	Hob
3	Front end
4	Front panel
5	Upper edge
6	Upper surface
7	Front surface
8	Rear surface
9	Switching and/or display element
10	Side wall
11	Ventilation slot
12	Bottom region
13	Opening
14	Heating element
15	Heating element
16	Heating element
17	Heating element
18	Ceramic stove top
19	Frame
20	Air
21	Opening
22	Air
23	Air
h	Height
B	Width
T	Depth
α	Angel
β	Angel
V	Vertical direction

Claims

1. Cooking appliance (1), especially domestic cooking appliance, having a hob (2) with a front end (3), **characterized in that** a front panel (4) is arranged at the front end (3) of the hob (2), wherein the front panel (4) has an upper edge (5) which is arranged above (h) the upper surface (6) of the hob (2).
2. Cooking appliance according to claim 1, **characterized in that** the front panel (4) extends substantial along the whole width (B) of the hob (2).
3. Cooking appliance according to claim 1 or 2, **characterized in that** the front panel (4) comprises a flat front surface (7).
4. Cooking appliance according to claim 3, **characterized in that** the plane of the front surface (7) extends with a small angel (α) to the vertical direction (V).
5. Cooking appliance according to claim 4, **characterized in that** the angel (α) is between 10° and 30°.
6. Cooking appliance according to at least one of claims 1 to 5, **characterized in that** the front panel (4) comprises a flat rear surface (8) facing the hob (2).
7. Cooking appliance according to claim 6, **characterized in that** the plane of the rear surface (8) extends in vertical direction (V).
8. Cooking appliance according to at least one of claims 1 to 7, **characterized in that** the front panel (4) has a substantial triangular form when viewed from the side.
9. Cooking appliance according to at least one of claims 1 to 8, **characterized in that** the height (h) of the upper edge (5) above the upper surface (6) of the hob (2) is between 15 % and 35 % of the depth (T) of the hob (2), preferably between 20 % and 30 %.
10. Cooking appliance according to at least one of claims 1 to 9, **characterized in that** at least one switching and/or display element (9) is arranged in the front surface (7) of the front panel (4).
11. Cooking appliance according to claim 10, **characterized in that** at least one switching element (9) is a touch screen element.
12. Cooking appliance according to claim 11, **characterized in that** the touch screen switching element (9) is of the TFT type.
13. Cooking appliance according to at least one of claims 1 to 12, **characterized in that** the front panel (4) has side walls (10) connecting the front surface (7) and the rear surface (8) of the front panel (4).
14. Cooking appliance according to claim 13, **characterized in that** the side walls (10) comprise at least one ventilation slot (11).
15. Cooking appliance according to claim 14, **characterized in that** at least one ventilation slot (11) is in fluidic connection with a bottom region (12) of the front panel (4).
16. Cooking appliance according to claim 15, **characterized in that** at least one opening (13) is arranged in the bottom region (12) of the front panel (4).
17. Cooking appliance according to at least one of claims 1 to 16, **characterized in that** the hob (2) is equipped with at least one heating element (14, 15, 16, 17).
18. Cooking appliance according to claim 17, **characterized in that** the heating element (14, 15, 16, 17) is an induction heating element.
19. Cooking appliance according to at least one of claims

1 to 18, **characterized in that** the hob is covered by a ceramic stove top (18).

- 20.** Cooking appliance according to claim 19, **characterized in that** the ceramic stove top (18) is free from switching and/or display elements (9).

10

15

20

25

30

35

40

45

50

55

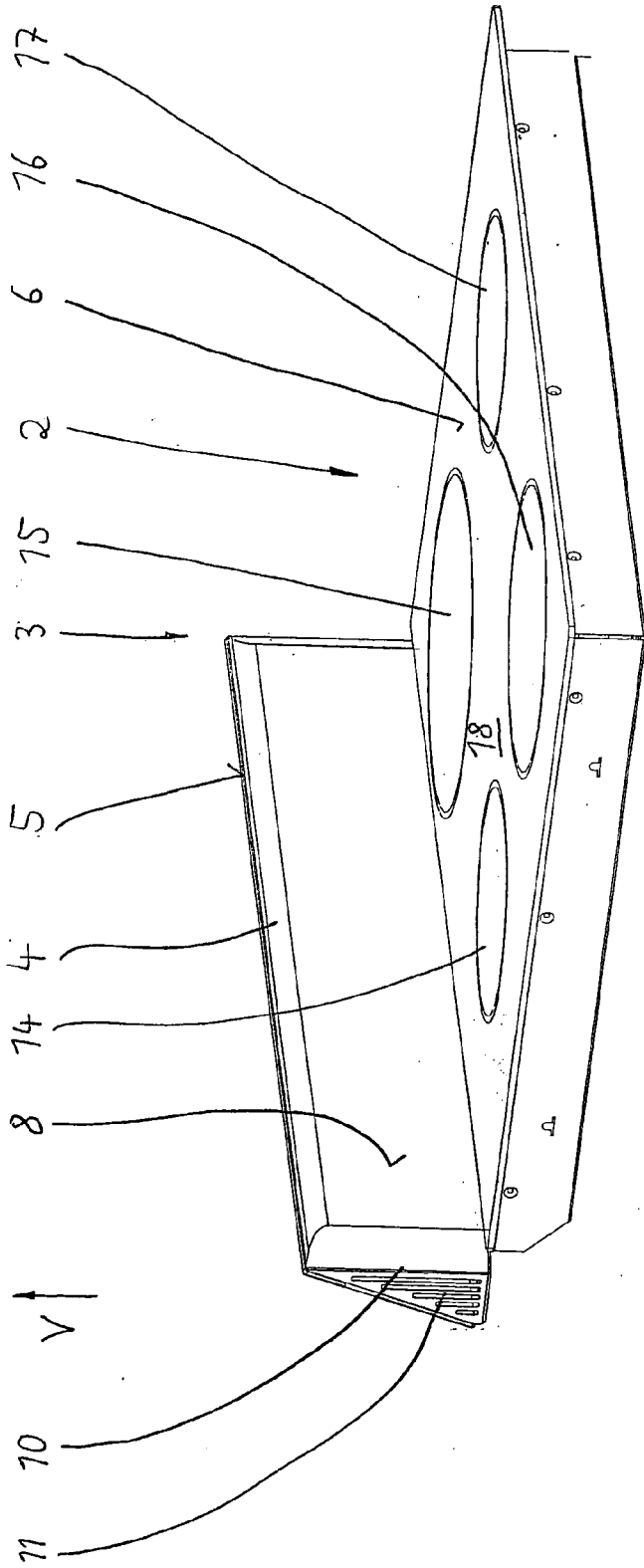

FIG 2

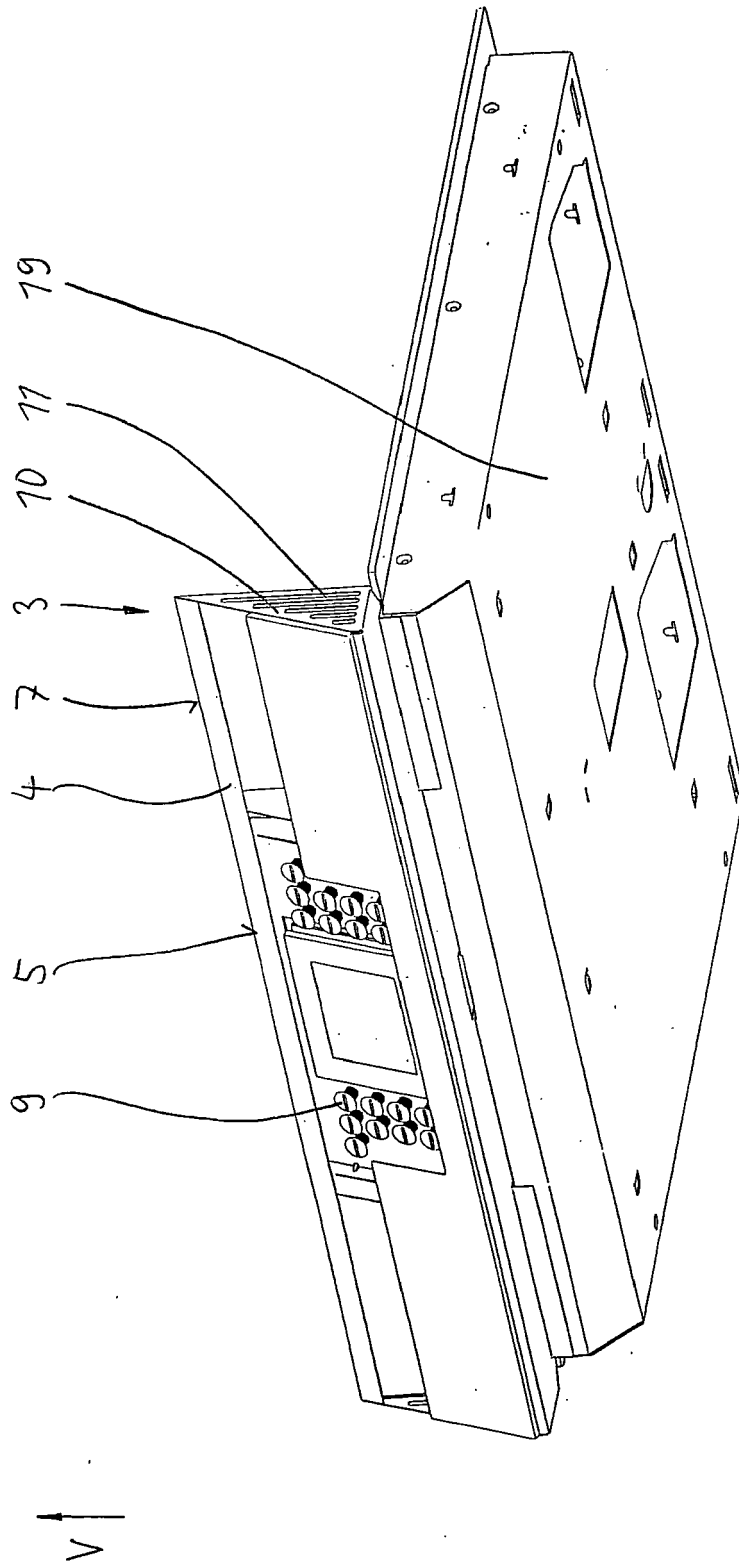

FIG 3

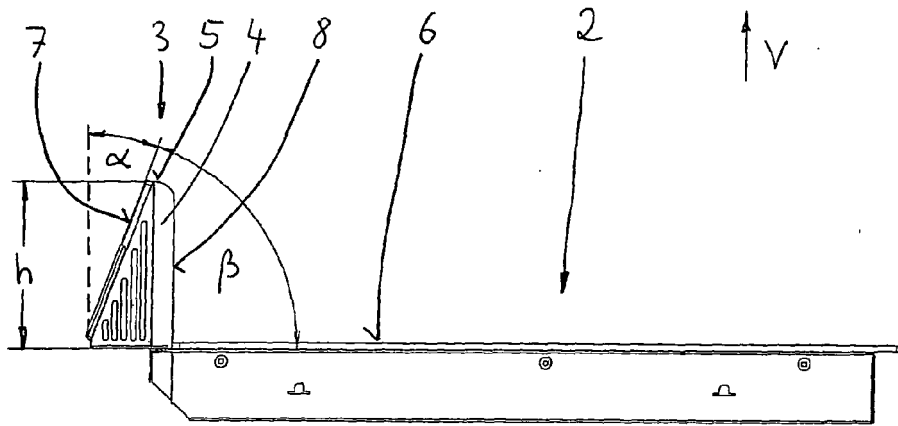

FIG 4

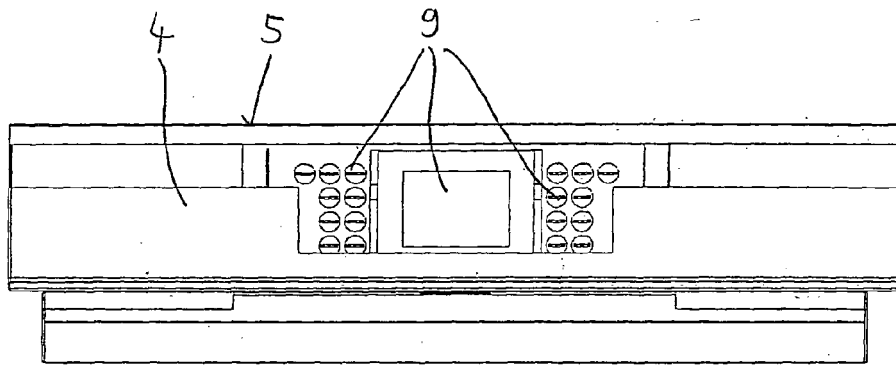

FIG 5

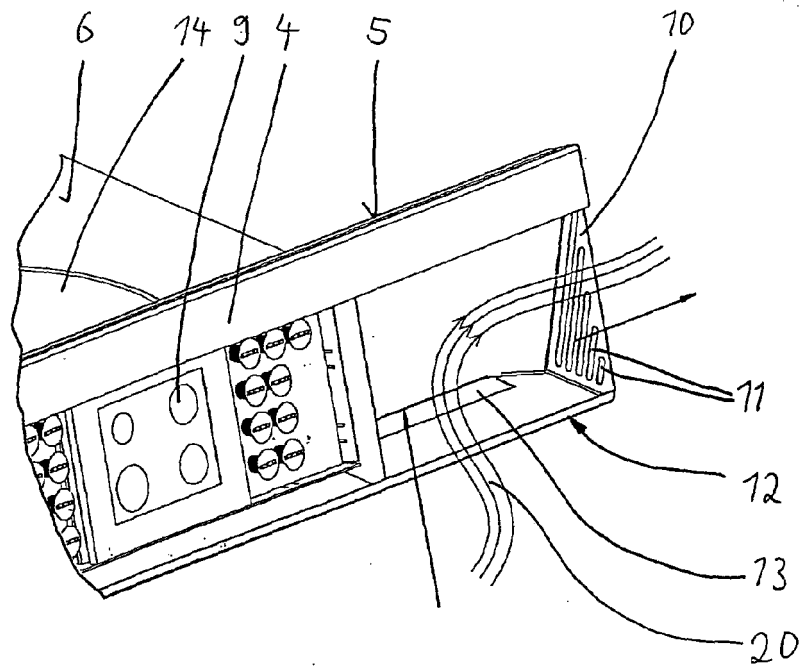

FIG 6



EUROPEAN SEARCH REPORT

Application Number
EP 07 02 3107

DOCUMENTS CONSIDERED TO BE RELEVANT			
Category	Citation of document with indication, where appropriate, of relevant passages	Relevant to claim	CLASSIFICATION OF THE APPLICATION (IPC)
X	DE 88 00 720 U1 (PICHERT, HORST, PROF. DR.-ING., 8000 MUENCHEN, DE) 19 May 1988 (1988-05-19) * the whole document * -----	1-7,9, 10,13,17	INV. F24C7/08 F24C15/36
X	DE 102 11 520 A1 (BSH BOSCH SIEMENS HAUSGERAETE [DE]) 25 September 2003 (2003-09-25) * column 3, line 45 - column 4, line 17; figures * -----	1-3,6-8, 10,11, 17,19,20	
X	EP 0 376 791 A (EUROP EQUIP MENAGER [FR]) 4 July 1990 (1990-07-04) * claims 1,8; figures * -----	1,2,17, 18	
A	* column 4, line 4 - line 45 *	13-16	
X	DE 199 61 457 A1 (BSH BOSCH SIEMENS HAUSGERAETE [DE]) 21 June 2001 (2001-06-21) * column 2, line 24 - line 59; figures * -----	1,3,6, 10-12, 17,19,20	
			TECHNICAL FIELDS SEARCHED (IPC)
			F24C
The present search report has been drawn up for all claims			
Place of search Munich		Date of completion of the search 19 December 2008	Examiner Rohr, Peter
CATEGORY OF CITED DOCUMENTS X : particularly relevant if taken alone Y : particularly relevant if combined with another document of the same category A : technological background O : non-written disclosure P : intermediate document		T : theory or principle underlying the invention E : earlier patent document, but published on, or after the filing date D : document cited in the application L : document cited for other reasons & : member of the same patent family, corresponding document	

2
EPO FORM 1503 03.82 (P04C01)

ANNEX TO THE EUROPEAN SEARCH REPORT
ON EUROPEAN PATENT APPLICATION NO.

EP 07 02 3107

This annex lists the patent family members relating to the patent documents cited in the above-mentioned European search report. The members are as contained in the European Patent Office EDP file on
The European Patent Office is in no way liable for these particulars which are merely given for the purpose of information.

19-12-2008

Patent document cited in search report	Publication date	Patent family member(s)	Publication date
DE 8800720	U1	19-05-1988	NONE

DE 10211520	A1	25-09-2003	FR 2837265 A1

EP 0376791	A	04-07-1990	DE 68901088 D1
			ES 2030293 T3
			FR 2641061 A1
			HK 71594 A
			JP 2219917 A
			SU 1808073 A3
			US 4983799 A

DE 19961457	A1	21-06-2001	NONE

EPO FORM P0459

For more details about this annex : see Official Journal of the European Patent Office, No. 12/82

REFERENCES CITED IN THE DESCRIPTION

This list of references cited by the applicant is for the reader's convenience only. It does not form part of the European patent document. Even though great care has been taken in compiling the references, errors or omissions cannot be excluded and the EPO disclaims all liability in this regard.

Patent documents cited in the description

- EP 0570670 A2 [0002]
- US 6455819 B1 [0002]
- EP 0570670 A1 [0002]