

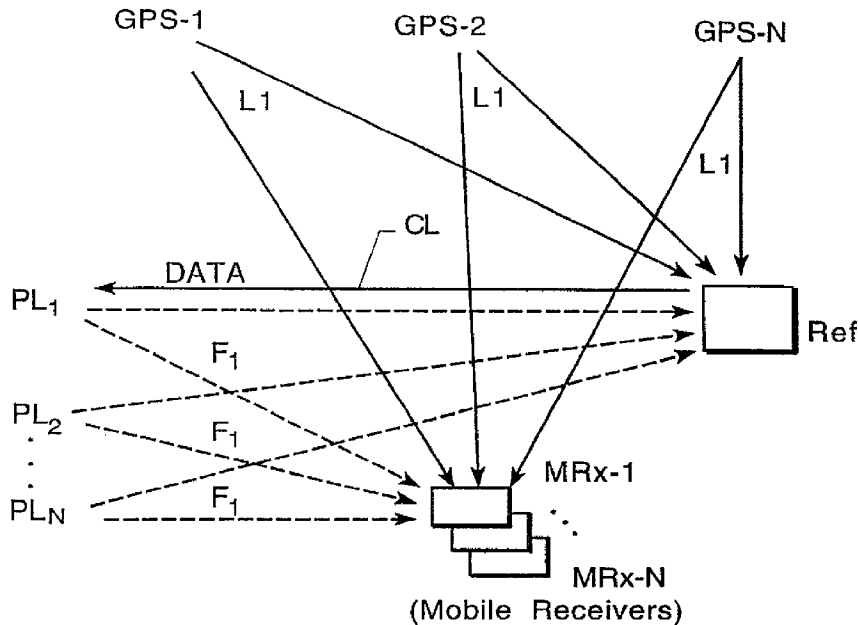

(72) HOLDEN, Thomas, US
(72) HANSON, Peter, US
(71) STANFORD TELECOMMUNICATIONS, INC., US
(51) Int.Cl.⁶ G01S 5/14
(30) 1996/02/01 (08/595,137) US
(54) **SYSTEME DE RADIONAVIGATION UTILISANT DES
PSEUDOLITES HORS BANDE**
(54) **RADIO NAVIGATION SYSTEM USING OUT-OF-BAND
PSEUDOLITES**



(57) La présente invention concerne un système d'émetteurs stationnaires de navigation par pseudolites permettant d'émettre, en environnement de signaux de navigation GPS large spectre utilisant une fréquence radio L1, un signal de type GPS utilisant une fréquence F1 autre qu'une fréquence de porteuse GPS. Une pluralité de stations pseudolites (PL) émet une pluralité de signaux de navigation GPS large spectre utilisant une fréquence radio F1, les fréquences de ces signaux étant différentes de la fréquence L1. L'invention comporte au moins une station de référence (REF) conçue pour recevoir les signaux de navigation GPS ainsi que les

(57) A system of stationary pseudolite navigation transmitters for broadcasting a GPS-like signal at a frequency F1, a non-GPS carrier frequency, is provided in the environment of GPS spread spectrum navigation signals at a radio frequency L1. A plurality of pseudolite stations (PL) broadcast a plurality of spread spectrum pseudolite navigation signals at a radio frequency F1 which are at a different frequency than the frequency L1. According to the invention, at least one reference station (REF) is provided for receiving the GPS navigation and the pseudolite navigation signals and deriving navigation correction data (Differential GPS, kinematic



signaux de navigation pseudolites, et pour en dériver les signaux des données de correction de navigation (GPS Différentiel, données d'observations cinématiques). L'une au moins des stations pseudolites sert de station maîtresse (PL1) en association avec chacune des stations de référence. Une liaison de télécommunications assure le transfert des signaux du GPS Différentiel et des données d'observation depuis chaque récepteur de référence vers l'une au moins de ses stations pseudolites modulant les données d'observation et d'intégrité de la station de référence pour émettre, à destination d'une pluralité de récepteurs mobiles (NRX), des signaux de navigation pseudolites et GPS, y compris les signaux de correction de navigation en provenance des stations pseudolites maîtresses, et produire, à partir de ces signaux, des informations de navigation précises en présence ou en l'absence de signaux de navigation GPS utiles.

observations data) signals. At least one of the pseudolite stations serves as a master station (PL1) in association with each reference station. A communication link provides differential GPS and observation data signals from each reference receiver to its master pseudolite station(s) which modulate(s) the reference station observations and integrity data for broadcasting to a plurality of mobile receivers (NRX) which receive the pseudolite and GPS navigation signals including the navigation correction signals from the master pseudolite stations and produce accurate navigation information therefrom in the presence or absence of useful GPS navigation signals.



PCT

WORLD INTELLECTUAL PROPERTY ORGANIZATION
International Bureau

INTERNATIONAL APPLICATION PUBLISHED UNDER THE PATENT COOPERATION TREATY (PCT)

(51) International Patent Classification ⁶ : G01S 5/02, H04B 7/185	A1	(11) International Publication Number: WO 97/28455 (43) International Publication Date: 7 August 1997 (07.08.97)
<p>(21) International Application Number: PCT/US97/01238</p> <p>(22) International Filing Date: 31 January 1997 (31.01.97)</p> <p>(30) Priority Data: 08/595,137 1 February 1996 (01.02.96) US</p> <p>(71) Applicant: STANFORD TELECOMMUNICATIONS, INC. [US/US]; 1221 Crossman Avenue, Sunnyvale, CA 94088 (US).</p> <p>(72) Inventors: HOLDEN, Thomas; 170 Pasito Terrace #811, Sunnyvale, CA 94086 (US). HANSON, Peter; 1100 Tewa Court, Fremont, CA 94536 (US).</p> <p>(74) Agent: ZEGERER, Jim; 801 North Pitt Street #108, Alexandria, VA 22314 (US).</p>	<p>(81) Designated States: AU, BR, CA, JP, KR, European patent (AT, BE, CH, DE, DK, ES, FI, FR, GB, GR, IE, IT, LU, MC, NL, PT, SE).</p> <p>Published <i>With international search report.</i> <i>Before the expiration of the time limit for amending the claims and to be republished in the event of the receipt of amendments.</i></p>	

(54) Title: RADIO NAVIGATION SYSTEM USING OUT-OF-BAND PSEUDOLITES

(57) Abstract

A system of stationary navigation pseudolite transmitters for broadcasting a GPS-like signal at a frequency F_1 , a non-GPS carrier frequency, is provided in the environment of GPS spread spectrum navigation signals at a radio frequency L_1 . A plurality of pseudolite stations (PL) broadcast a plurality of spread spectrum pseudolite navigation signals at a radio frequency F_1 which are at a different frequency than the frequency L_1 . According to the invention, at least one reference station (REF) is provided for receiving the GPS navigation and the pseudolite navigation signals and deriving navigation correction data (Differential GPS, kinematic observations data) signals. At least one of the pseudolite stations serves as a master station (PL1) in association with each reference station. A communication link provides differential GPS and observation data signals from each reference receiver to its master pseudolite station(s) which modulate(s) the reference station observations and integrity data for broadcasting to a plurality of mobile receivers (NRX) which receive the pseudolite and GPS navigation signals including the navigation correction signals from the master pseudolite stations and produce accurate navigation information therefrom in the presence or absence of useful GPS navigation signals.

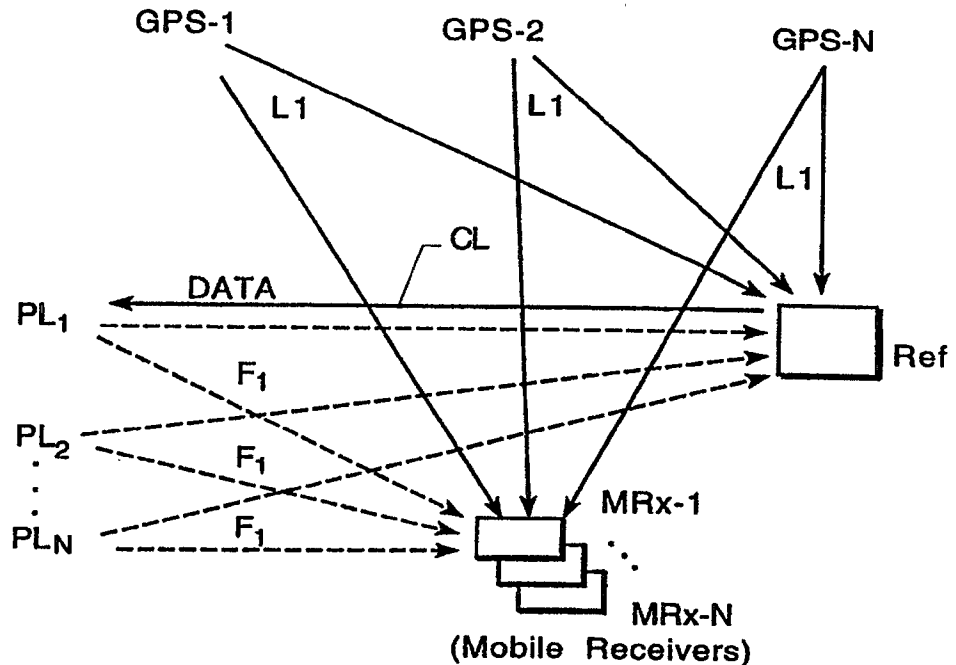

RADIO NAVIGATION SYSTEM USING OUT-OF-BAND PSEUDOLITES

The present invention relates to a radio navigation system using out-of-band pseudolites in an environment of the Global Position System (GPS) navigation system.

In the GPS navigation system a plurality of satellite vehicles orbiting the earth broadcast direct sequence spread spectrum signals at a frequency L1 and by receiving a plurality of GPS satellite vehicles very accurate location or navigation information can be derived at almost any position on earth that is visible (in a radio sense) to the satellites. Stationary ground reference stations are used to provide differential correction signals to mobile navigation receivers so that the position signals are extremely accurate and can be used for land surveys, for example. However there can be locations and times when there are insufficient GPS satellite vehicles visible.

The objective of the present invention is to provide a navigation system that is available at all times in a given area and to provide a navigation system wherein if no GPS satellites are visible, or an insufficient number of GPS satellites are available, a system of pseudolites, including a reference station and a master pseudolite station, are available for providing pseudolite navigation signals for extremely accurate navigation signals to the remote mobile receivers in a given area.

SUMMARY OF THE INVENTION

The invention overlays a system of stationary pseudolite navigation

transmitters for broadcasting a GPS like signal at a frequency F1, a non-GPS carrier frequency, in the environment of GPS spread spectrum navigation signals at a radio frequency L1. A plurality of pseudolite stations broadcast a plurality of spread spectrum pseudolite navigation signals at a radio frequency F1 which are at a different frequency than the frequency L1. According to the invention, at least one reference station is provided for receiving the GPS navigation and the pseudolite navigation signals and deriving navigation correction data (differential GPS, kinematic observations data) signals. At least one of the pseudolite stations serves as a master station in association with each reference station. A communication link provides differential GPS and observation data signals from each reference receiver to its master pseudolite stations which modulate the reference station observations and integrity data for broadcasting to a plurality of mobile receivers which receive the pseudolite and GPS navigation signals including the navigation correction signals from the master pseudolite stations and produce accurate navigation information therefrom in the presence or absence of useful GPS navigation signals.

The present invention differs with respect to in-band pseudolites in the following particulars:

1. Non-GPS F1 frequencies are available to wider range of potential customers without danger of interfering with existing GPS facilities.
2. Prior art includes use of near GPS frequencies- e.g., within about 1-10

C/A code nulls (approximately 10 MHz) of L1 (See B. D. Elrod and A. J. Van Dierendonck, "Testing and Evaluation of GPS Augmented with Pseudolites for Precision Landing Applications," *Proceedings of DSNS '93*, Amsterdam, The Netherlands, 31 March 1993.), WAAS testing within about 2.5% of nominal GPS L1 frequencies, and the technique up to 3.5% different from nominal GPS described in Brown US patent number 5,311,194.

3. In these cases, only trivial modifications are required to receive the signals- the signals are "in-band" as far as the receiver architectures are concerned. In addition, the detailed signal paths within the receiver can be made to be identical, further simplifying the modeling task.

4. The present invention relaxes the range of F1 to be almost arbitrary. Candidate frequencies in the USA at this time appear to be 1.9 GHz and 2.4 GHz, for example.

5. Non-GPS frequencies F1 observations can be combined with GPS observations to jointly form both carrier-smoothed DGPS and/or kinematic solutions as shown herein.

6. The present invention does not assume pseudolite broadcasts are synchronized, neither with one another, nor with GPS.

The present invention differs with respect to conventional GPS in the following particulars:

1. The present invention employs pseudolites to augment GPS range observations. (Conventional DGPS provides no additional range observations).
2. Pseudolites may employ pulsing to mitigate near/far limitations.
3. At least one pseudolite broadcasts DGPS reference information, in addition to range observations. (DGPS uses separate communication resource).
4. GPS augmentation may radically collapse time to achieve On-the-Fly

(OTF) kinematic solution.

DESCRIPTION OF THE DRAWINGS

The above and other objects, advantages and features of the invention will become more apparent when considered with the following specification and accompanying drawings wherein:

Fig. 1 is a schematic illustration of a GPS-pseudolite navigation system incorporating the invention,

Fig. 2 is a block diagram of a master pseudolite incorporated in the invention,

Fig. 3 is a block diagram of a receiver incorporated in the invention, (the REF and MRX receivers being preferably, identical except with respect to the uses of their outputs), and

Fig. 4 is a block diagram of an auxiliary pseudolite reference station as used in the invention.

DETAILED DESCRIPTION OF THE INVENTION

Referring to Fig. 1, a constellation of GPS satellites GPS-1, GPS-2.....GPS-N provide basic service to most areas including the area to be served by the system of pseudolites PL-1, PL-2....PL-N. The area to be served may have any number or plurality of mobile receivers MRX-1, MRX-2.....MRX-N. One or more of the reference receivers REF are provided and are capable of receiving the GPS signals at frequency L1 and also the GPS-like signals from the pseudolite

stations PL-1, PL-2....PL-N at a frequency F1 which can be chosen over a wide range and need not be near the GPS frequency L1. A communication link CL, which may be land line, microwave, fiber optic, a short set of wires, etc. from the reference receiver REF to one or more of the pseudolites PL-1, PL-2...PL-N supplies Differential GPS (DGPS), kinematic observations and integrity data to the pseudolites. The pseudolites transmit GPS-like spread spectrum signals at frequency F1 to reference station REF and the mobile receivers MRX-1, MRX-2.....MRX-N in order to augment the GPS signals. One of the pseudolite stations in this system (PL-1) has been designated a master pseudolite station. The master pseudolite modulates the observation and integrity data received from the reference station REF over communication link CL, thereby broadcasting this information to the MRX population.

The mobile receivers MRX are capable of receiving GPS signals at frequency L1 and the GPS-like signals from the pseudolite stations PL-1, PL-2...PL-N at frequency F1. Receiver elements best realized as exact copy of element at the reference station REF in order for best opportunity for implementation dependent errors to cancel out. Since these are true receivers, (i.e., they need not transmit signals), there may be any number of them in the service area.

If no GPS satellites are visible or in line-of-sight within the service area (e.g., at the reference receiver REF), the system may operate without GPS. In that case, it replaces GPS, rather than augmenting it, and the GPS time is not available. If one GPS satellite is available within the service area, e.g., at the reference receiver REF, the system can transfer GPS time to the mobile receivers

MRX as limited by observation errors and conventional limits of the Navstar GPS Standard Positioning Service. Carrier-smoothed code (pseudo-range, PR) observations are possible with only one GPS satellite visible. The pseudolites can augment this PR, but must fully replace GPS if true kinematic solutions are to be derived. If two or more GPS satellites are available, GPS time can be transferred and GPS observations can participate in the kinematic solution.

The reference receiver is preferably adapted to handle the observations of the non-master pseudolite stations. The invention contemplates reducing these PRs modulo a preset value (set at above twice the expected maximum measurement range). The reference station observations may be compressed to be suitable for broadcast. For example, the most significant bits (MSB) of range and rate may be infrequently broadcast, with frequent updates supplied relative to these values, thus reducing the number of bits required. Note that the non-master pseudolites need not be synchronized to GPS or any other pseudolite. This may present special problems at the receivers, since the resulting PR values are far more arbitrary than true GPS. The master pseudolite may be synchronized to GPS (if any) by means of observing its own DGPS terms in the communication link CL between the reference station REF and the master pseudolite station. This is not required but may be useful if pseudolites PL can replace GPS within part of the service area and when GPS time is useful.

Like the reference receiver REF, the MRX will need to handle observations of the non-master pseudolites.

In general, there must be at least one reference station, and at least one master pseudolite per reference station. However, there can be multiple reference stations, and multiple master pseudolites can be connected to modulate the observation and integrity data from any reference station. Systems may incorporate multiple reference stations to provide the benefits of improved system reliability and to extend the service area. Reliability improves when several reference signals are available to the typical MRX. A larger area may be served while maintaining nominal accuracy by spreading reference stations to cover it evenly; i.e., so that there is a fixed upper limit to the distance from an MRX to its closest available reference station. Accuracy at each MRX is limited by the distance from that MRX to the reference station it is using.

This incorporation of multiple master pseudolites may be required in the following situations. In some cases it is seen that a single master pseudolite source may not illuminate the desired coverage area. These areas could include regions near blockages, such as near bridges, large buildings and docks ; regions near moving blockages such as ships; or regions with highly irregular terrain, such as canyons, mines and factories.

Referring to Fig.2 a reference frequency source such as crystal oscillator CO or other stable frequency source SFS is selected by selection switch SSw as a source for multi-synthesizer MS which generates and outputs a control signal f_{control} , a carrier $\cos \underline{w}f_1(t)$, and f_{code} from one of the selected input reference

frequencies. Oscillator CO is a crystal oscillator or better. The control unit CU receives f_{control} and selectively uses an external interface EXT/INT for control and/or is interfaced to a reference receiver which provides advantageously both GPS reference observations and PL broadcast data and outputs a control signal to code generator CG. Code generator CG generates a spread spectrum code at a rate selected by use of the frequency f_{code} and has the ability to modulate a data pattern on the spread spectrum code. The $\cos \omega f_1(t)$ signal is binary phase shift keyed (BPSK) in modulator or mixer M. Optionally, a pulser P controlled by an output of control block CU can be used to provide greater effective dynamic range at the receiver and the thus formulated signal is amplified and broadcast to all of the mobile receivers MRX.

Referring to the receiver block diagram illustrated in Fig. 3, antenna and front end A receives the L1 and F1 signals and splits the output, supplying dual GPS-like receivers R1 and R2, respectively. Receiver R1 is a traditional GPS receiver for processing the L1 signal frequencies and receiver R2 has slight modifications for processing the \sim signal frequencies. Both receivers are locked to frequency and timing signal inputs from frequency and timing synthesizer FTS which is supplied with a base frequency from source CO. Frequency and timing synthesizer FTS generates reference and timing signals to coordinate receivers R1 and R2 and to drive control microprocessor CMP. Control microprocessor CMP provides high level control and integrates the observations and data of receivers

R1 and R2. Reference interface RI outputs the reference link data to communication link CL which is connected to the master pseudolite. The solution output interface SO provides the navigation information to the user via a utilization device, which may be a display, a recorder or perform a control or guidance function. The following table sets out some of the parameters:

Input Freq.	code rate	data rate	data format and content	Examples
1575.42	1.023	50 bps	ICD-GPS-200	NovaTel RT-20
F1	fcode = 1.023 (typical, others possible)	f_{code} ----- ≥ 1000 f_{data}	variant of WAAS/LAAS	GSV 1012 (modif. for F1)

An exemplary block diagram of an auxiliary pseudolite reference REF (Fig. 1) is illustrated in Fig. 4, which parallels Fig. 2. This example assumes BPSK modulation of frequency F1. The pulser function block P' again is optional. It provides a way of pulsing or chopping the output signal for greater effective dynamic range at the receiver. Oscillator OSC-2 is also of the quartz crystal oscillator family or better. The auxiliary pseudolite does not require an external time base input. As indicated the pseudolite has provision for external interface EXT INT and control. The pseudolite optionally broadcasts its location if known. The multi-synthesizer MS' and code generator CG' are the same as described in connection with Fig. 2. The control element or microprocessor CMP' selects the spread spectrum code and any data to be modulated on it, and generates the

pulsing element control signal and provides external interface signals. Its timing is derived from the multi-synthesizer. The control element or microprocessor controls the selection of the SS code, the pulsing control and services the external interface.

While preferred embodiments of the invention have been shown and described, it will be appreciated that various modifications and adaptations of the invention will be obvious to those skilled in the art and it is intended that the claims encompass such modification~ and adaptations.

WHAT IS CLAIMED IS:

PCT/US 97/01238

IPEA/US 13 FEB 1998

11

CLAIMS

1. A navigation system in an environment of GPS spread spectrum navigation signals at a radio frequency L1 comprising,

a plurality of pseudolite stations for broadcasting a plurality of spread spectrum pseudolite navigation signals at a radio frequency F1 which are at a different frequency greater than 5% of said frequency L1, at least one of said pseudolite stations comprising a master pseudolite station for each reference receiver,

at least one reference station for receiving said GPS navigation and said pseudolite navigation signals and deriving correction data (differential GPS, kinematic observations data) signals,

a communication link forming means for providing differential GPS and observation data signals from each of said reference receiver station to at least one of said master pseudolite stations,

a plurality of mobile receivers for receiving said pseudolite and GPS navigation signals including said navigation correction signals from said master pseudolite station and producing accurate navigation information therefrom in the presence or absence of useful GPS navigation signals.

2. A navigation system as defined in claim 1 wherein all pseudolites transmit one of a 1) GPS-like signal or 2) non-GPS code modulation to further reduce interference with GPS and improve the quality rate of the observations at the plurality of user receivers, respectively.

3. A navigation system as defined in claim 1 wherein said pseudolite stations are not synchronized with said reference receivers.

PCT/US 97/01238

IPEA/US 13 FEB 1998

12

4. A navigation system as defined in claim 1 wherein said pseudolite transmissions are pulsed so as to improve the near far problem encountered in continuous RF transmission code division multiple access systems.

5. A navigation system as defined in claim 1 wherein said mobile receivers combine L1 and F1 observations into a single solution, including code differential GPS solutions, carrier-phase smoothed differential GPS solutions, and kinematic differential GPS solutions.

6. A navigation system as defined in claim 1 wherein the frequency offset of the pseudolite transmissions at F1 provides interference protection from signal jammers in the L1 frequency region and in a region with a plurality of pseudolite transmissions allows the system to continue to function and provide navigation solution based upon the number of pseudolite signals that each of the plurality of mobile receivers can track in its receiver, respectively.

AMENDED SHEET

1 / 2

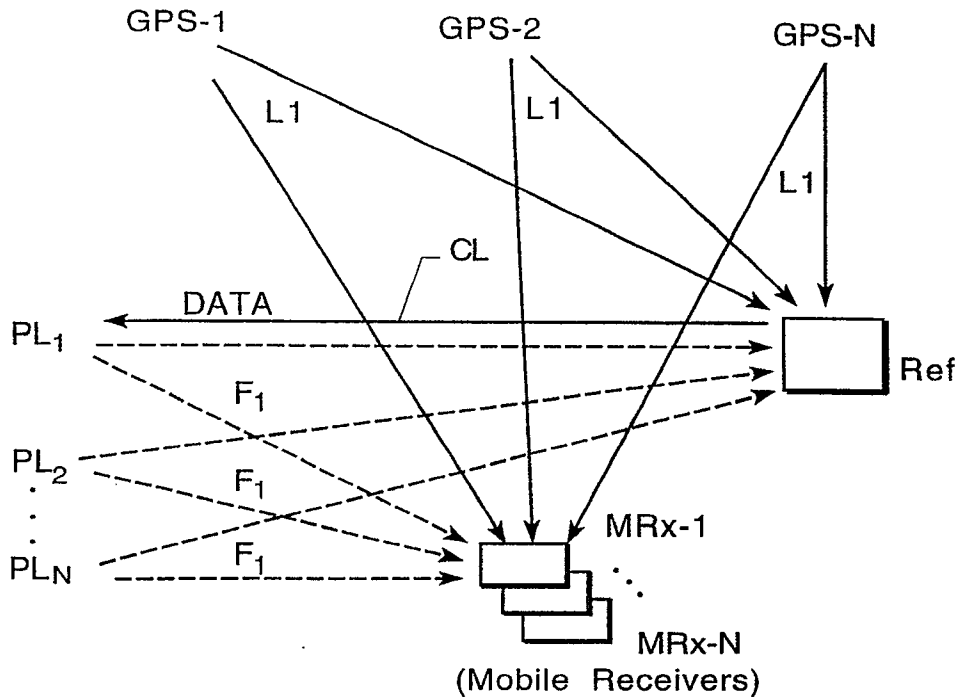

FIG. 1

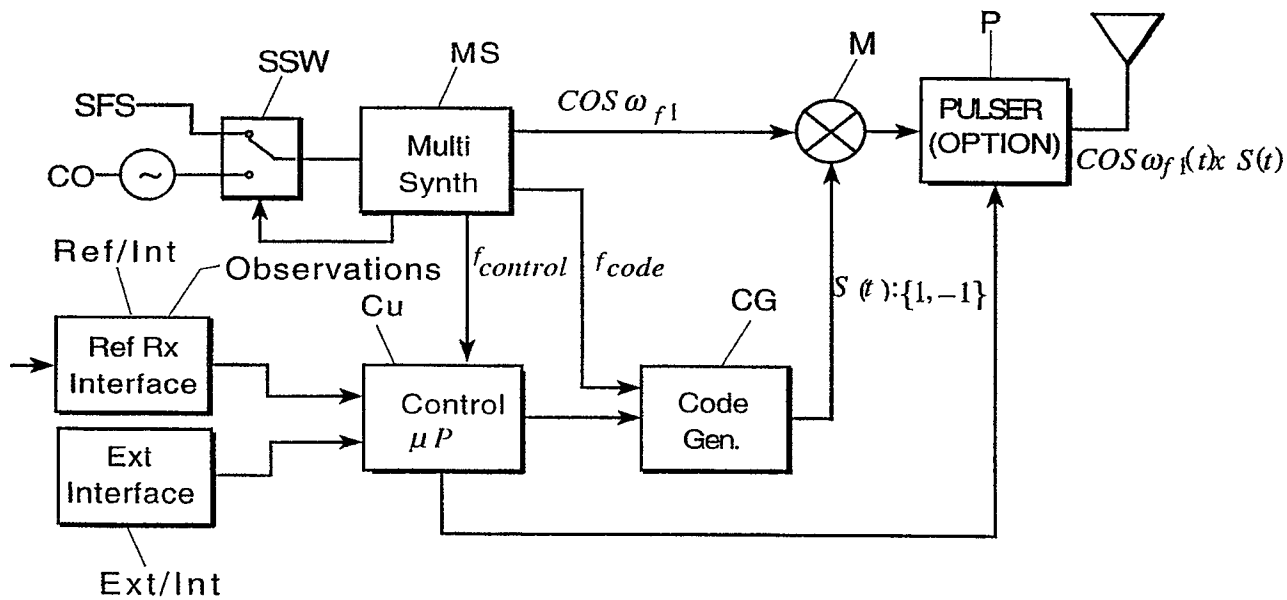

FIG. 2

2 / 2

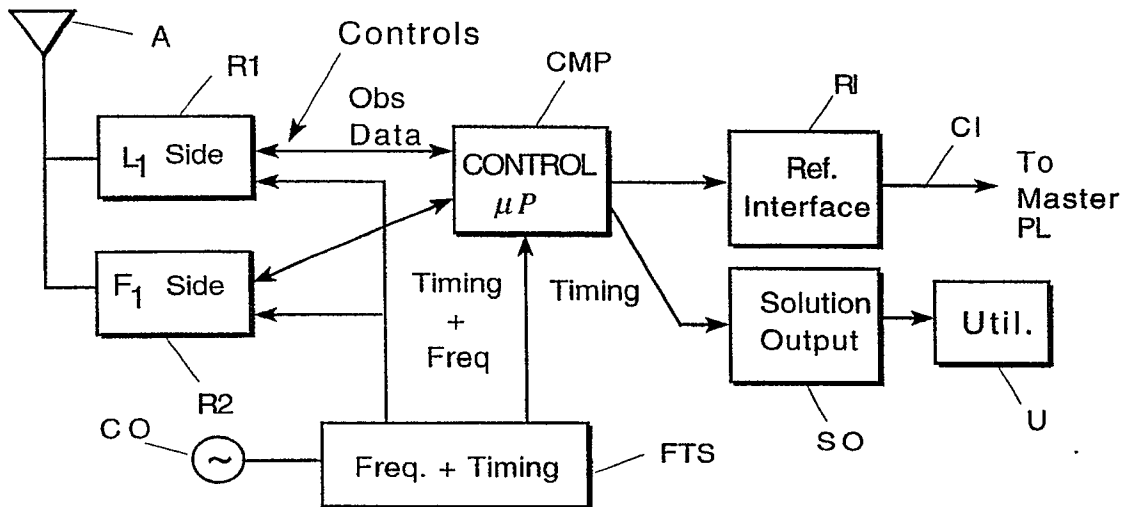
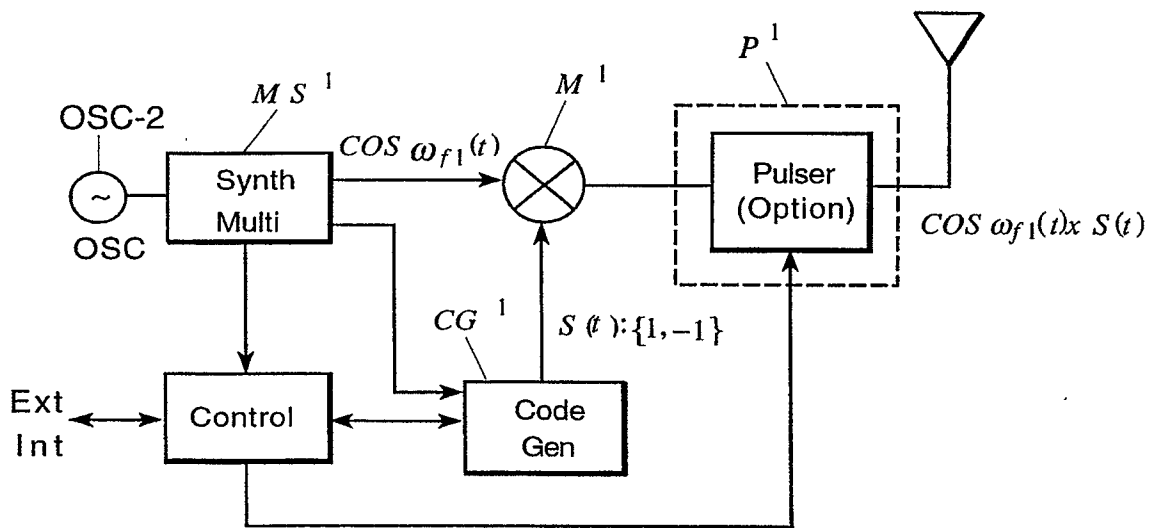

FIG. 3



Auxiliary PL

FIG. 4

