

S. M. STEVENS.
 APPARATUS FOR PUMPING WATER.
 APPLICATION FILED APR. 27, 1910.

Patented Oct. 18, 1910.

973,230.

Fig. 1

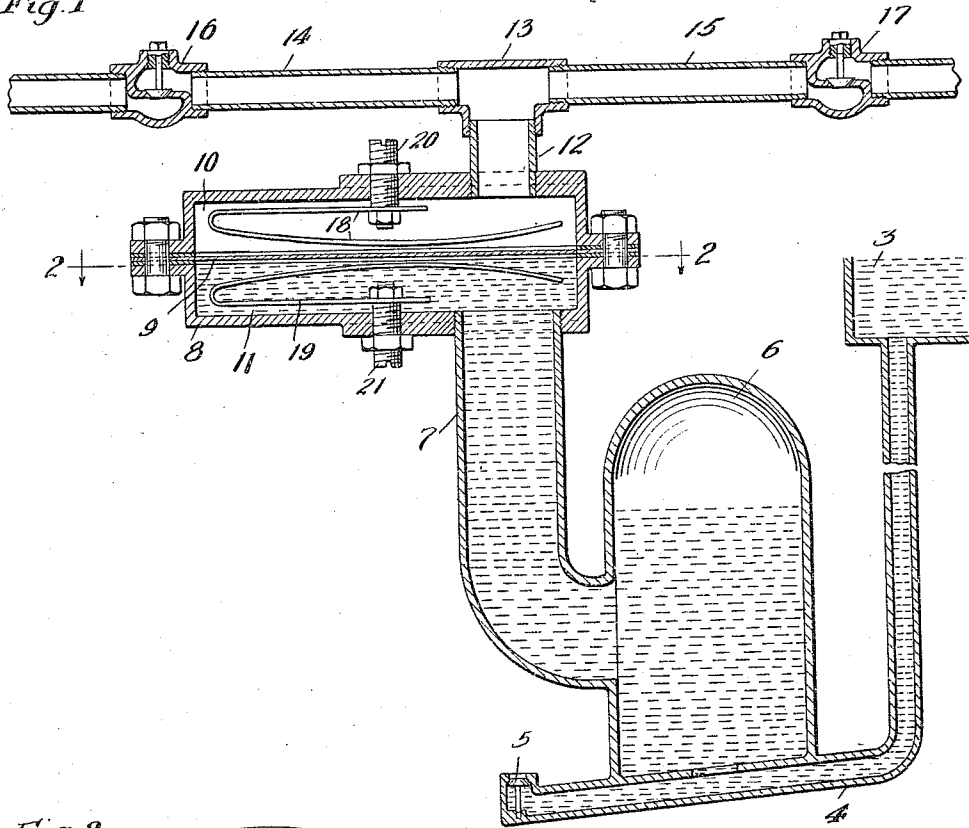
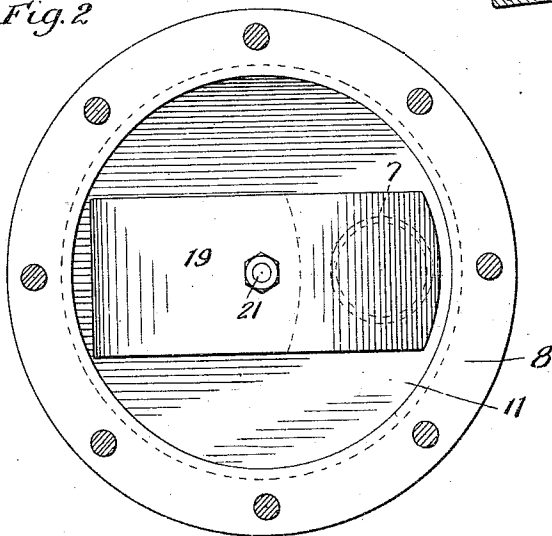

Fig. 2



Witnesses:

Wm. Geiger
 Pearl Abrams.

Inventor

Sidney M. Stevens
 By Munday Evans, Adcock & Clarke
 Attorneys

UNITED STATES PATENT OFFICE.

SIDNEY M. STEVENS, OF PRINCE GEORGE, VIRGINIA, ASSIGNOR OF ONE-HALF TO GRANT CHASE, OF PRINCE GEORGE, VIRGINIA.

APPARATUS FOR PUMPING WATER.

973,230.

Specification of Letters Patent.

Patented Oct. 18, 1910.

Application filed April 27, 1910. Serial No. 557,983.

To all whom it may concern:

Be it known that I, SIDNEY M. STEVENS, a citizen of the United States, residing in Prince George, in the county of Prince George and State of Virginia, have invented a new and useful Improvement in Apparatus for Pumping Water, of which the following is a specification.

This invention relates to the construction of apparatus for raising water, and its object has been to provide an inexpensive construction of automatic apparatus adapted to raise the water in cases where only limited volume is needed.

The invention is fully described below, and also illustrated in the accompanying drawing in which,

Figure 1 is a vertical section of the apparatus and Fig. 2 a section on the line 2—2 of Fig. 1.

In said drawing I show a novel construction of pumping apparatus in combination with a hydraulic ram for operating the same. This hydraulic ram may be of any known construction, and the one shown is a form illustrated in *Knight's Mechanical Dictionary*. In it the water passes from a reservoir or source of supply 3, through the pipe 4 at the lower end of which is a check valve 5, serving as a waste valve to the apparatus. When the water closes this valve, it spends its energy in forcing a portion of itself into the air chamber 6, thus relieving some of the pressure at the valve so that it drops and causes a resumption of the movement through pipe 4 until the valve is again lifted, when the same operations are repeated. The chamber 6 communicates by pipe 7 with a casing 8 in which is located the pumping apparatus now to be described. This casing is horizontally arranged as shown and is divided by a horizontal diaphragm 9 into upper and lower chambers 10 and 11. Of these the lower chamber receives the water from pipe 7, and the upper one receives the water which is to be pumped through a pipe 12. The pipe 12 is joined to a tee 13, one end of which connects with a pipe 14 leading from a spring or other source of supply, and the other end of the tee is joined to a pipe 15 leading to the point at which the water from the spring is to be used or delivered. The pipe 14 is provided with a check valve 16 adapted to admit the water freely to the pipe but also adapted to prevent any return of

the water, and pipe 15 is likewise provided with a check valve 17 adapted to permit the passage of the water to the point of destination, but also adapted to prevent the water after it has moved beyond said valve from returning.

The diaphragm 9 is flexible and adapted to yield to the pressure of the water upon its flat faces and it is accompanied upon both faces with assisting springs. The spring above the diaphragm is indicated at 18 and the one below it is indicated at 19. Both are made from flat metal bent into U shape, and the former is secured to the top of the casing by the screw 20 passing through the shorter limb of the spring, and the lower spring 19 is secured in like manner to the bottom of the casing by the screw 21 also passing through the shorter limb of the spring.

With the construction described, the operation is substantially as follows: The water from the spring enters through valve 16 and fills pipe 14 and the upper chamber 10 of the pumping casing, depressing the diaphragm to a greater or less extent, forcing it against the spring 19. The ram now acts by creating superior pressure on the underside of the diaphragm and raising it. In so doing the water above the diaphragm is lifted, compelling the closing of the valve 16 so that no more water can enter. At the same time the greater or less part of the water then accumulated above the diaphragm is expelled through valve 17, and sent on its way to the point of delivery. As soon as the ram reacts, the pressure from the water caused by it ceases and the diaphragm falls to its normal position, thereby permitting the water to again enter at valve 16, and to fill the space just vacated by that which was expelled. These operations are repeated as long as the ram is continued in action.

It will be noted that the screws 20 and 21 which support the springs 18 and 19, are adapted to position said springs at different distances from the diaphragm, so that the action of the springs may be lessened or increased as occasion requires. This enables me to regulate these springs, so as to adapt the apparatus to use in cases not only where the spring water is under considerable pressure as it enters but also in cases where there is no pressure upon it. If there is pressure upon it, the springs are adjusted so as to

put greater tension upon the lower spring and slacken that upon the upper one. It will also be noted that the spring water which is pumped, does not become mixed
5 with or adulterated by the water used in the ram. Indeed the latter may be very much inferior to the former.

The apparatus described is adapted to exert a suction force on the water being
10 pumped, so that it is adapted not only to draw the water into itself in the absence of any pressure upon the water, but also to raise the water from a well or other source lower than itself.

15 I claim:—

1. The apparatus for pumping water consisting of a water holding casing, a flexible diaphragm dividing said casing into two compartments, a water supplying and dis-
20 charging pipe communicating with one of said compartments, a hydraulic ram communicating with the other of said compartments and serving to actuate said diaphragm, and assisting springs at each side
25 of said diaphragm.

2. The apparatus for pumping water con-

sisting of a water holding casing, a flexible diaphragm dividing said casing into two compartments, a water supplying and dis-
30 charging pipe communicating with one of said compartments, a hydraulic ram communicating with the other of said compartments and serving to actuate said diaphragm, and assisting springs at each side of
35 said diaphragm, said assisting springs being adjustable.

3. The apparatus for pumping water consisting of a water holding casing, a flexible diaphragm dividing the casing into two compartments, a water supply pipe opening
40 into one of said compartments, a hydraulic ram communicating with the other compartment and supplying power to operate the diaphragm, and adjusting springs at
45 each side of said diaphragm, said springs being independently adjustable in both directions.

SIDNEY M. STEVENS.

Witnesses:

W. E. ARMSTRONG,
V. M. CAMPBELL.