



US00D477205S

(12) **United States Design Patent**
Sakai et al.

(10) **Patent No.:** **US D477,205 S**

(45) **Date of Patent:** **** Jul. 15, 2003**

(54) **IMPACT DRIVER**

(75) Inventors: **Masato Sakai, Ibaraki (JP); Masanori Watanabe, Ibaraki (JP); Katsuhiro Oomori, Ibaraki (JP); Takuya Teranishi, Ibaraki (JP)**

(73) Assignee: **Hitachi Koki Co., Ltd., Tokyo (JP)**

(**) Term: **14 Years**

(21) Appl. No.: **29/144,049**

(22) Filed: **Jun. 26, 2001**

(30) **Foreign Application Priority Data**

Dec. 27, 2000 (JP) 2000-037338

(51) **LOC (7) Cl.** **08-05**

(52) **U.S. Cl.** **D8/68**

(58) **Field of Search** D8/61, 62, 63, D8/64, 65, 66, 67, 68, 69, 70, 107; 29/243.525; 74/371; 81/52, 54, 55, 57, 57.11, 57.13, 57.14, 57.42, 57.43, 177.1, 177.4, 177.6, 177.85, 409, 429, 436, 463, 464, 466, 474, 900, 901, DIG. 12; 173/13, 15, 47, 48, 90, 91, 92, 93, 93.5, 93.6, 109, 112, 122, 164, 169, 170, 171, 176, 213, 216, 217; 227/51, 81, 138; 279/9.1, 19.3, 62, 137, 142, 147, 149, 158; 310/50; 320/114; 408/20, 120, 122, 124, 125, 234, 241 R, 241 S; 451/344, 354, 357, 358, 359, 456

(56) **References Cited**

U.S. PATENT DOCUMENTS

D156,319 S * 12/1949 Bushnell D8/68

D295,714 S * 5/1988 Sasaki et al. D8/68
D339,046 S * 9/1993 Fushiya et al. D8/68
D340,396 S * 10/1993 Ichikawa D8/68
D342,430 S * 12/1993 Saito et al. D8/68
D392,863 S * 3/1998 Sugimoto et al. D8/68
D424,902 S * 5/2000 Gildersleeve et al. D8/68
D435,414 S * 12/2000 Etter et al. D8/68
D437,761 S * 2/2001 Okumura et al. D8/68

* cited by examiner

Primary Examiner—Doris V. Coles

Assistant Examiner—T. Chase Nelson

(74) *Attorney, Agent, or Firm*—Sughrue Mion, PLLC

(57) **CLAIM**

The ornamental design for an impact driver, as shown and described.

DESCRIPTION

FIG. 1 is a perspective view of the top, front and left side of an impact driver showing our new design;

FIG. 2 is a front view thereof;

FIG. 3 is a rear view thereof;

FIG. 4 is a left side view thereof;

FIG. 5 is a right side view thereof;

FIG. 6 is a top view thereof;

FIG. 7 is a bottom view thereof; and,

FIG. 8 is a perspective view of the top, rear, and right side thereof with the hook disposed on the rear and pivoted upwardly.

1 Claim, 6 Drawing Sheets

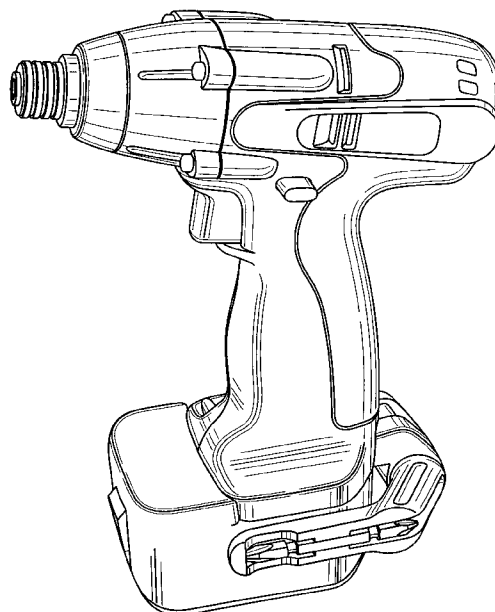

FIG. 1

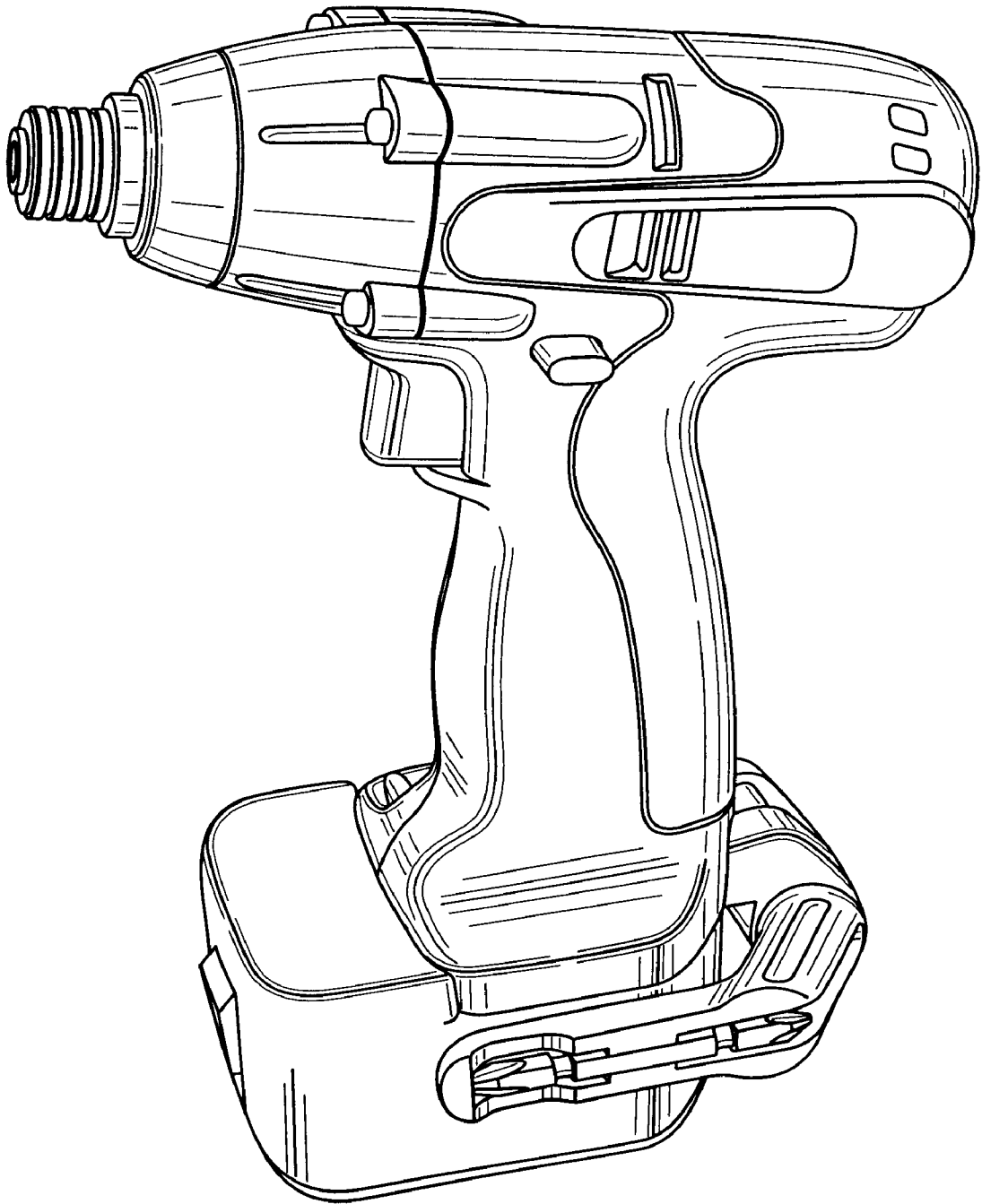

FIG. 2

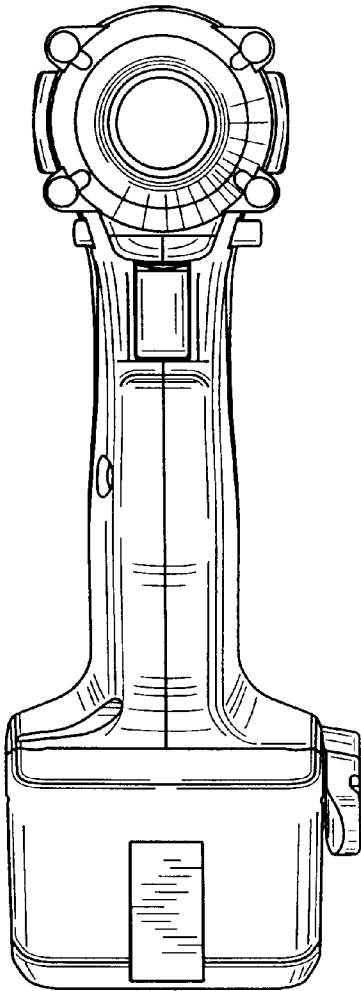

FIG. 3

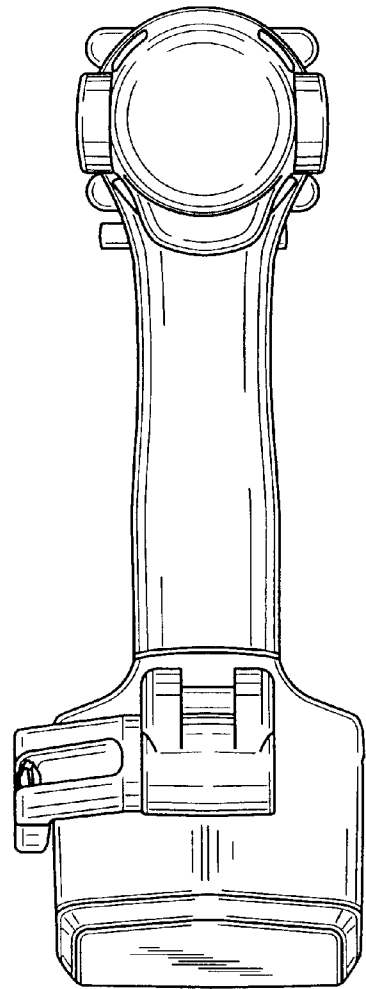

FIG. 4

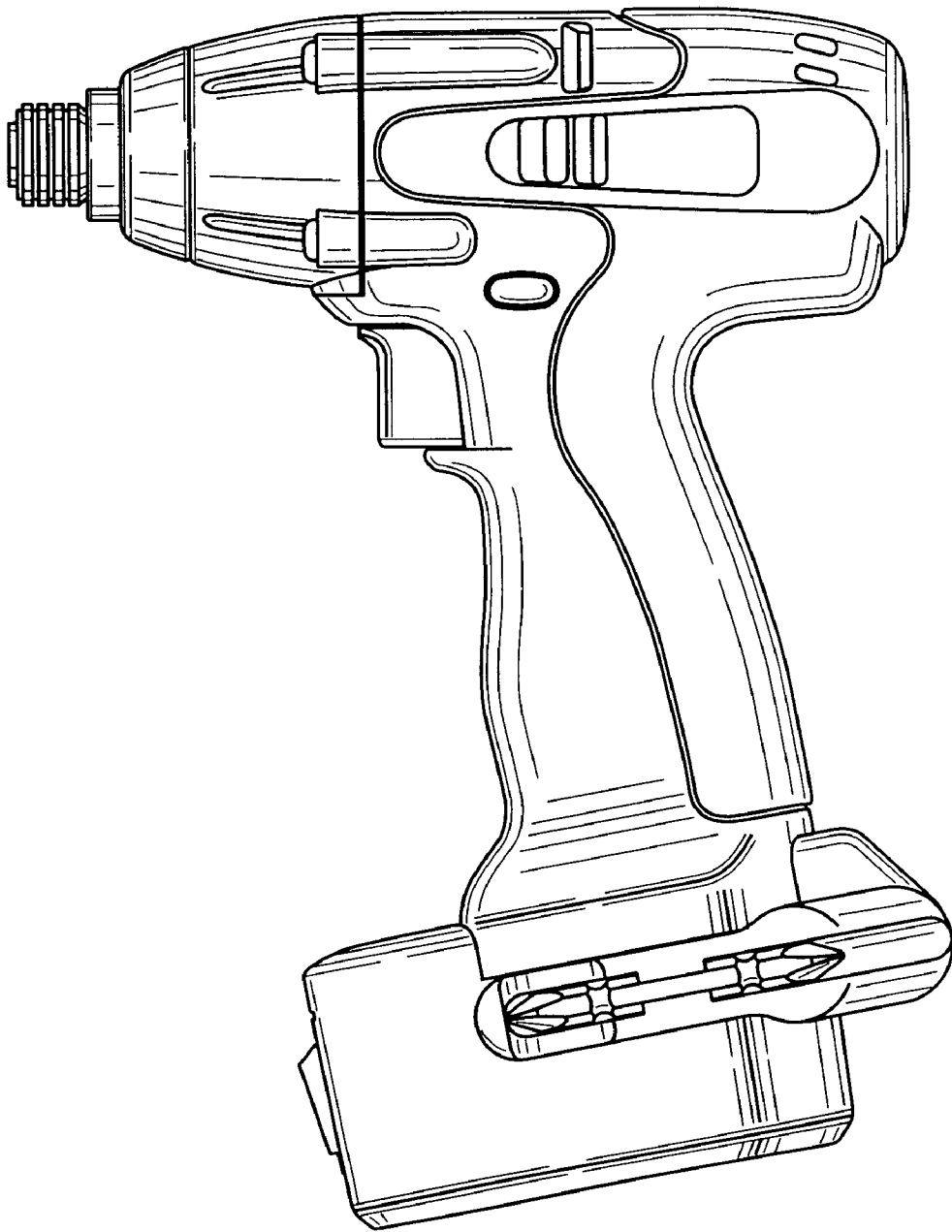

FIG. 5

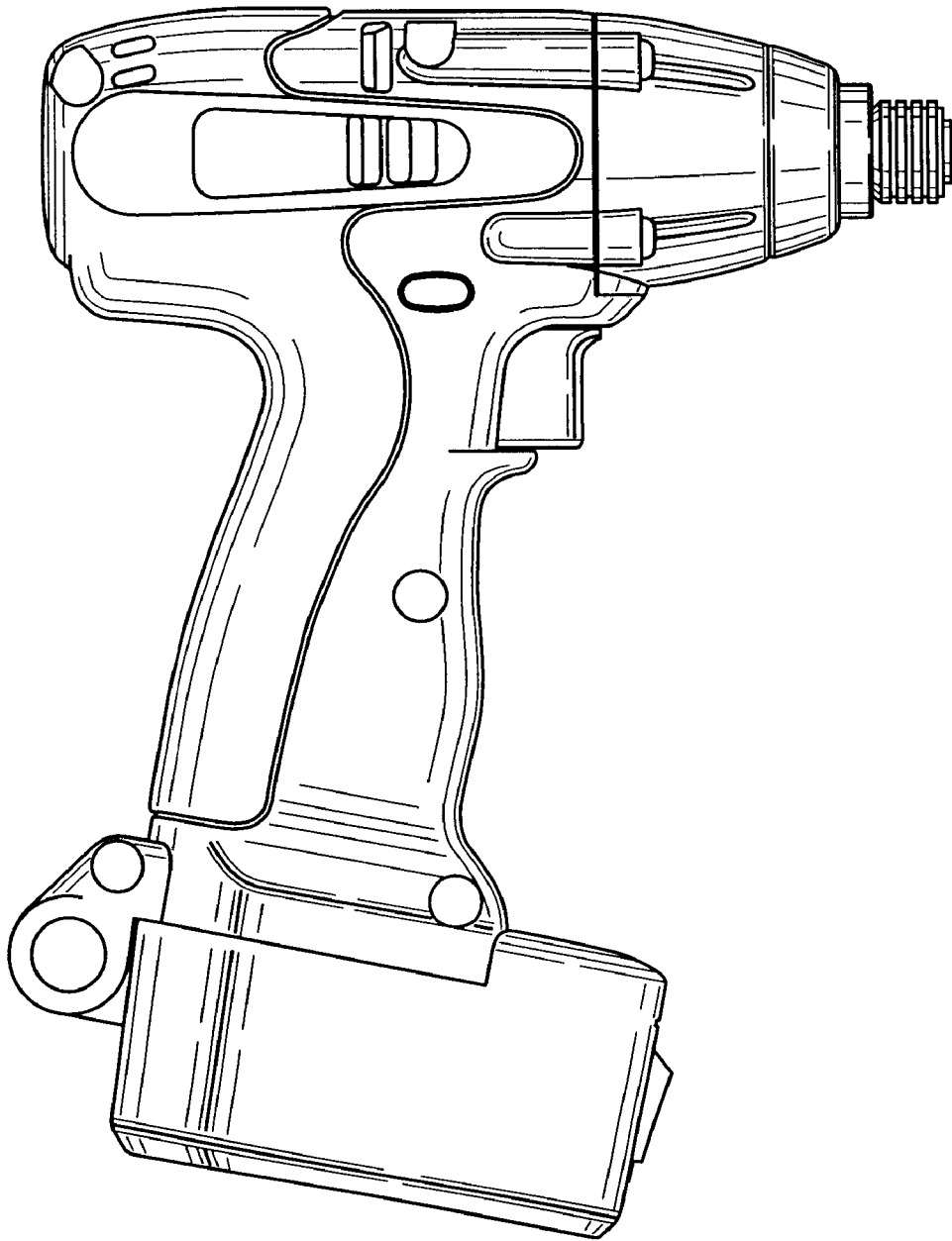

FIG. 6

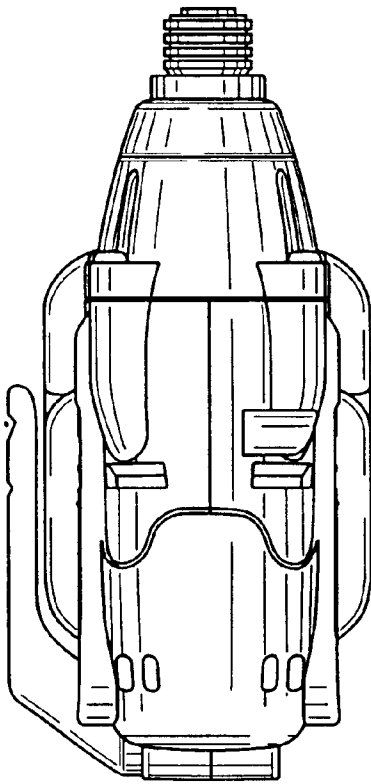

FIG. 7

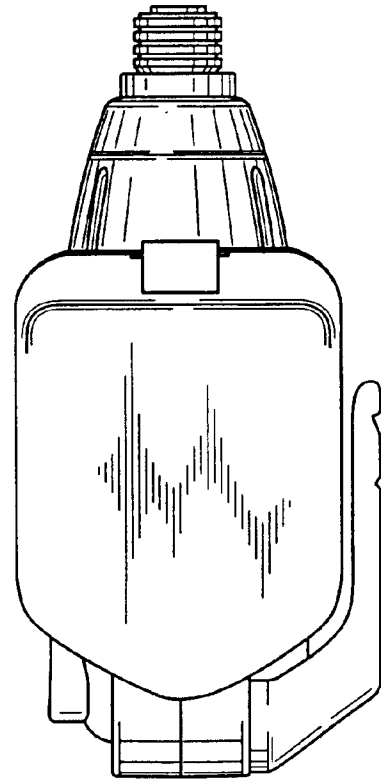

FIG. 8

