



INTERNATIONAL APPLICATION PUBLISHED UNDER THE PATENT COOPERATION TREATY (PCT)

(51) International Patent Classification ⁵ : B65D 25/06, 1/24	A1	(11) International Publication Number: WO 91/07327 (43) International Publication Date: 30 May 1991 (30.05.91)
--	-----------	--

<p>(21) International Application Number: PCT/SE90/00712</p> <p>(22) International Filing Date: 5 November 1990 (05.11.90)</p> <p>(30) Priority data: 8903809-5 13 November 1989 (13.11.89) SE</p> <p>(71) Applicant (for all designated States except US): PLASTIC FORM GF AB [SE/SE]; Box 39, S-335 00 Gnosjö (SE).</p> <p>(72) Inventor; and (75) Inventor/Applicant (for US only) : FREDRIKSSON, Gösta [SE/SE]; Villa Lövhuddan, S-335 00 Gnosjö (SE).</p> <p>(74) Agent: WALLENGREN, Yngvar; Patentbyrån Y Wallengren AB, Box 116, S-331 21 Värnamo (SE).</p>	<p>(81) Designated States: AT (European patent), BE (European patent), CH (European patent), DE (Utility model), DE (European patent), DK, DK (European patent), ES (European patent), FI, FR (European patent), GB (European patent), GR (European patent), IT (European patent), LU (European patent), NL (European patent), NO, SE (European patent), US.</p> <p>Published <i>With international search report.</i></p>
--	---

(54) Title: IMPROVEMENTS IN STORAGE CRATES

(57) Abstract

A bottle crate has a bottom and vertical corner posts (3) which are connected at the top via top pieces (4) so that the crate has openings (6) in its sides. The crate has an insert (2) divided into compartments (7), the insert being displaceable between a lower position where it blocks the openings (6) and an upper position where it permits laterally directed removal of the bottles. The insert (2) is guided in the crate by the intermediary of guide surfaces (12, 13). To achieve ready displacement of the insert (2) without "jammed drawer" effects, one or other or both of the guide surfaces (12, 13) have a surface structure with projecting and recessed surface portions so that diversion or accommodation spaces for foreign particles are created. The guide surfaces consist of guide grooves (12) in the corner posts (3) and corresponding elongate strips (13) on the insert (2). The strips (13) and the grooves (12) are approximately complementary and the surface structure is disposed on the strips (13).

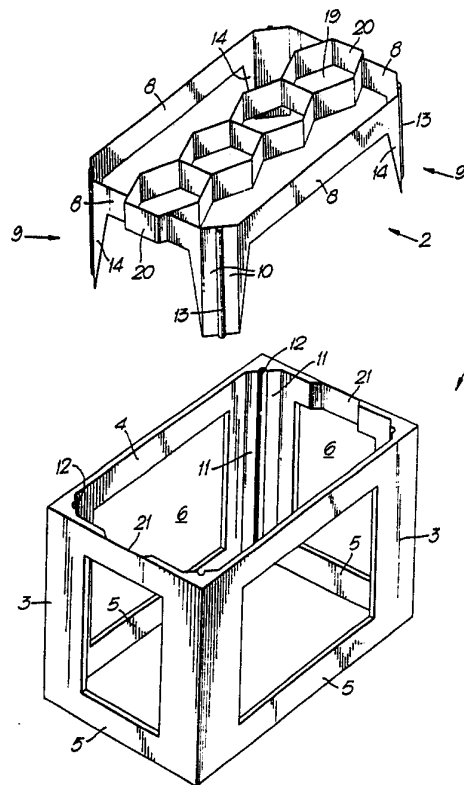

FOR THE PURPOSES OF INFORMATION ONLY

Codes used to identify States party to the PCT on the front pages of pamphlets publishing international applications under the PCT.

AT	Austria	FI	Finland	ML	Mali
AU	Australia	FR	France	MN	Mongolia
BB	Barbados	GA	Gabon	MR	Mauritania
BE	Belgium	GB	United Kingdom	MW	Malawi
BF	Burkina Faso	GN	Guinea	NL	Netherlands
BG	Bulgaria	GR	Greece	NO	Norway
BJ	Benin	HU	Hungary	PL	Poland
BR	Brazil	IT	Italy	RO	Romania
CA	Canada	JP	Japan	SD	Sudan
CF	Central African Republic	KP	Democratic People's Republic of Korea	SE	Sweden
CG	Congo	KR	Republic of Korea	SN	Senegal
CH	Switzerland	LI	Liechtenstein	SU	Soviet Union
CI	Côte d'Ivoire	LK	Sri Lanka	TD	Chad
CM	Cameroon	LU	Luxembourg	TG	Togo
DE	Germany	MC	Monaco	US	United States of America
DK	Denmark	MG	Madagascar		
ES	Spain				

IMPROVEMENTS IN STORAGE CRATES

TECHNICAL FIELD

The present invention relates to an apparatus in a storage crate for objects such as cans, bottles or the like and which comprises partly a crate with a bottom and corner portions upstanding therefrom, the corner portions being, at the top, connected with top pieces, where-
5 by the crate has an opening in at least one side wall, and partly an insert disposed in the crate and provided with compartments for the objects, the insert being displaceable, in the vertical direction of the crate, between a lower position where it blocks the opening and an upper position where it permits laterally directed removal of the
10 objects through the opening, the insert being guided in the crate by the intermediary of guide surfaces in the corner regions of the crate and the insert.

BACKGROUND ART

15

A crate of the type mentioned by way of introduction is known from SE-B-407 779. The crate according to this publication has arched corner regions which serve to guide the insert displaceably disposed in the crate. The insert is designed with vertically directed legs
20 which have an arching corresponding to the corner arching of the crate so that thereby the legs guide the insert on its displacement in the crate.

The crate according to this Swedish publication suffers from serious
25 drawbacks in that the vertical movement of the insert may not readily be effected. Thus, so-called "jammed drawer" effects are manifest when attempts are made to slide the insert vertically. Hence, a ready and reliable guiding of the movement of the insert will not be achieved with the above-described design and construction.

30

A factor which further aggravates the situation is that foreign particles, dirt or the like have a propensity to become trapped between

mutually sliding surfaces, whereby the movement capacity of the insert is greatly impaired.

PROBLEM STRUCTURE

5

The present invention has for its object to develop the apparatus described by way of introduction to such an extent that it offers a reliable and freely-running guide for the insert when this is displaced vertically. Thus, the invention has for its object to reduce, as far as possible, the friction between the insert and the crate and to eliminate "jammed drawer" effects when the insert is slidingly displaced. The present invention further has for its object to realise an apparatus which is not sensitive to dirt attack or foreign particles.

15

SOLUTION

The objects forming the basis of the present invention will be attained if the apparatus disclosed by way of introduction is characterised in that one or other of mutually cooperating guide surfaces has a surface structure with protruding and recessed surface portions, whereby the effective friction surface between cooperating guide surfaces is reduced and diversion or accommodation spaces for foreign matter or particles are created.

25

According to one advantageous embodiment of the present invention, the corner portions are also designed as hollow, closed profiles, the corner portions having a vertical guide groove formed from the wall material of the profile and constituting the guide surface on the corner portion, while the insert has a guide projection which is accommodated in the guide groove and which constitutes the guide surface of the insert, the guide projection being of a configuration which is approximately complementary to the configuration of the guide groove.

35

In order to minimise as far as possible the costs for the tools in which the storage crate is produced, it suitably further applies

according to the present invention that the above-mentioned surface structure is disposed on the guide surfaces of the insert.

Further advantages will be attained according to the present invention if the apparatus is also given one or more of the characterising features as set forth in appended Claims 4-6.

BRIEF DESCRIPTION OF THE ACCOMPANYING DRAWINGS

The invention will now be described in greater detail hereinbelow, reference being had to the accompanying Drawings, in which:

Fig. 1 is, in perspective, an exploded illustration of a crate designed according to the present invention; and

Fig. 2 is an exploded illustration showing a horizontal section through a corner portion of the crate and its insert.

DESCRIPTION OF PREFERRED EMBODIMENT

Fig. 1 shows a storage crate for bottles, cans and similar objects which is intended partly for transport and partly for direct sale of the objects. The storage crate is designed in such a manner that it is composed of two different parts, viz. an outer case or crate 1 and an insert 2 mounted therein and provided with a compartment unit for the objects. In the position of use of the storage crate, the insert 2 is placed interiorly in the outer case 1 or crate by being slid down into the crate from above.

According to the invention, the crate 1 has substantially smooth and even inner defining surfaces and a bottom which is not specified more closely on the Drawing but which is preferably produced from a grid construction. On its outside, the crate has a number of rigidifying fillets directed transversely or at right angles to the side walls, the fillets, however, not being shown in Fig. 1. Hereby, the side walls will have requisite rigidity and mechanical strength.

It will further be apparent from the Drawing that the crate 1 is composed of four corner portions in the form of tubular, downwardly open posts or profiles 3 which, at the upper end of the crate, are connected via horizontally directed top pieces 4. Furthermore, the
5 crate is provided, along the bottom, with lower side pieces 5 which, in the vertical direction, are preferably of lesser extent than the top pieces 4. As a result of this design and construction, the crate will have an opening 6 in each side surface. However, as an intimately related and self-evident modification, it is conceivable that
10 at least certain of the side surfaces be closed by providing panel-like means in place of the openings, possibly provided with rigidifying fillets. Furthermore, the corner portions may of course be wider so that together they may at least partly or completely cover one side surface of the crate.

15 As is apparent from the Drawing, the insert 2 is composed of a compartment unit 7 which, in the illustrated embodiment, has compartments designed as equilateral hexagons. A single row of such compartments is shown in the Figure, but it will be obvious that identical or similar compartments are disposed in the entire compartment
20 unit, with one row on either side of that illustrated.

The compartment unit 7 has an outer defining frame 8 which defines a nominal outer contour of the compartment unit. This defining frame
25 is produced from upright strip or panel material and is of a height which approximately corresponds to the height of the top pieces 4 of the crate 1. Furthermore, the defining frame 8 and the compartment unit 7 are preferably of the same height.

30 In the corner regions, the defining frame 8 has downwardly directed legs 9 which have outwardly facing guide surfaces 10 which are preferably disposed at an angle of 45° in relation to the sides of the defining frame 8. The guide surfaces 10 are arranged to guide against corner surfaces 11 disposed interiorly in the crate 1 and of
35 approximately the same width as the guide surfaces 10. These corner surfaces 11 are produced as one side of the closed profile which constitutes the corner posts 3.

As intimated by way of introduction, the insert is movable in the crate in the vertical direction thereof and switchable between a lower position where the compartment unit 7 blocks the openings 6 in the side surfaces of the crate. This is achieved in that the downwardly directed legs 9 have been given a suitable height for this purpose. In order to permit ready upward and downward displacement of the compartment unit, it is crucial that fully adequate guiding be realised so that so-called "jammed drawer" effects will thereby be eliminated as far as possible when the compartment unit is displaced. For this reason, the corner surfaces 11 in the crate 1 are provided with guide grooves 12, guide projections 13 on the legs 9 of the insert 2 running in these guide grooves. The guide grooves 12 are also created directly in the closed profile which forms the corner posts 3, whereby the walls defining the guide grooves will also be walls in the closed profile.

Ideally, dimensioning of the legs 9, the guide surfaces 10, the guide grooves 12 and the corner surfaces 11 may be adapted such that the major guiding function is realised by the guide grooves 12 and the guide projections 13. However, in heavier loadings, the guide surfaces 10 may come into abutment against the corner surfaces 11 in order to reinforce the guiding function.

It will further be apparent from the Drawing that the downwardly directed legs 9 have side surfaces 14, whereby the stability of the legs is considerably improved.

The function of the above-described crate is such that, once the insert 2 has been mounted in the crate 1 and this filled with bottles, the insert 2 is in a standing position with the legs 9 against the bottom of the crate. In this position, the compartment unit 7 will be located roughly in the middle of the crate viewed vertically so that thereby the compartment unit blocks the openings 6. In this position, the objects may only be removed from the crate upwardly. If, for example in retail premises, several crates are stacked on one another, this entails that removal of the objects may take place only upwardly from the uppermost crate.

However, as was mentioned above, the insert 2 is slidable in the vertical direction and may be slid to an upper position where the compartment unit is substantially concealed behind the top pieces 4. In this position, an object may be lifted slightly so that its bottom comes to a level higher than the upper edge of the lower side pieces 5. In this state, the object may be pivoted laterally and removed bottom-first through one or other of the openings 6. Hence, as a result of the present design of the crate, it is possible laterally to remove objects from any optional crate, even in the middle of a stack of crates.

Fig. 2 shows a horizontal section through a corner region of the crate 1, as well as a top plan view of a corner region of the insert 2. It will be apparent from this Figure that the corner portion 3 or corner post is designed as a closed profile which is open downwardly towards the underside of the crate. It will also be apparent that the bottom of the crate is designed with a grid lattice of ribs 18 and that the openings 6 in the side surfaces of the crate are defined by rigidifying fillets 16 and 17 disposed on the outside of the crate.

It is further apparent from the Drawing that the corner post 3 is designed as a hollow profile comprising two outer walls 25 approximately normal to one another, and a corner surface 11 facing the interior of the crate and making an angle of approx. 45° with both of the outer walls 25. Between the outer edges of the corner surfaces 11 and the outer walls 25, there are provided inwardly extending walls 26 so that the profile is thereby closed. These inwardly directed walls are approximately normal to the corner wall or surface 11. It will further be apparent from the Drawing that the vertical rigidifying fillets 17 defining the openings 6 may also be considered as included in the profile forming the corner portion.

According to the invention, the corner wall 11 has a longitudinal guide groove 12 which is of a gently arched, approximately U-shaped contour. This guide groove 12 serves for accommodating and guiding

a guide projection 13 which is disposed on the guide surfaces or corner surfaces 10 of the insert 2. The cross-sectional configuration of the guide projection 13 is suitably complementary to the configuration of the groove 12. Furthermore, the guide projection
5 extends vertically throughout the entire height of the leg 9. However, the guide projection 13 may be replaced by a series of projections distributed along the leg 9.

The dimensioning of the insert 2 and the crate 1 is such that, in
10 normal loading, the groove 12 guides the insert 2 by cooperation with the projection 13 or series of projections. However, in certain exaggerated loading situations, the guide surfaces 10 may also come into abutment and guiding engagement with the corner surfaces 11 of the corner portions.

15 Already by employing guide projections 13 and guide grooves 12 alone, the size of the friction surfaces operating against one another when the insert is slid in the vertical direction will be greatly reduced. Hereby, the major advantage will be gained that it
20 becomes easier for foreign particles, dirt and the like to depart from those surfaces which move relative to one another than would be the case involving large, continuous friction surfaces.

In order further to reduce friction and increase dependability in
25 the movement of the insert 2, one or other of the mutually cooperating guide surfaces on the projection 13 and the groove 12 has a surface structure which comprises projecting and recessed surface portions. Hereby, the tops of the projecting surface portions will, on movement of the insert, slide against a smooth surface on the
30 other guide surface, whereby the effective friction surface is greatly reduced. In addition, accommodation or diversion spaces are formed at the recessed surface portions, for foreign particles, dirt or the like so that, thereby, such particles do not run the risk of becoming embedded in the plastic material of the guide surfaces so
35 that these are damaged and the insert 2 becomes jammed.

Those surface portions of the guide surfaces which are displaced relative to the mean surface of the guide surface may be of sizes of from a few tenths of a millimetre up to a few millimetres.

- 5 The location of the surface portions displaced from the mean surface is of no consequence to the function of the present invention but, on the other hand, considerable production engineering advantages are gained if these surface portions are placed on the guide surface 13 on the insert 2.

10

In one practical embodiment, the surface structure may be realised in that the guide surface is generally rough or granular. Furthermore, various types of more or less regular striated patterns may of course be employed, mention here being made by way of one example of
15 a design in which the guide surface 13 has longitudinally directed projecting strips or ridges between which corresponding depressions or grooves are disposed. In another example, projecting ridges and interjacent grooves may be transversely directed in relation to the longitudinal direction of the guide surface 13, and also trans-
20 versely directed in relation to the direction of movement of the insert 2.

When the crate according to the present invention is used and objects are to be removed through one of the openings 6, it is advantageous if the insert 2 may be positionally fixed or locked in the
25 uppermost end position. According to the invention, the surface structure includes means for such positional fixing of the insert. Further such positional fixing measures may be implemented in that the groove 12 is provided with a tapering upper portion where direct
30 clamping of the insert 2 may take place. Furthermore, snap locking devices pure and simple may be utilised for positionally fixing the insert 2 in its upper position.

The present invention may be further modified without departing from
35 the spirit and scope of the appended Claims.

WHAT IS CLAIMED IS:

1. An apparatus in storage crates for objects such as cans, bottles or the like, comprising a crate (1) with a bottom (18) and corner portions (3) upstanding therefrom, the corner portions being connected at the top to top pieces (4), whereby the crate has an opening (6) in at least one side wall, an insert (2) disposed in the crate and provided with compartments (7) for the objects, the insert being, in the vertical direction of the crate, slidable between a lower position where it blocks the opening and an upper position where it permits laterally directed removal of the objects through the opening, the insert being guided in the crate via guide surfaces (12, 13) in the corner regions of the crate and the insert, **characterised in that** one or other of mutually cooperating guide surfaces (12, 13) has a surface structure with projecting and recessed surface portions, whereby the effective friction surface between cooperating surfaces is reduced and diversion or accommodation spaces for foreign matter or particles are created.
2. The apparatus as claimed in Claim 1, **characterised in that** the corner portions (3) are designed as hollow, closed profiles; and that the corner portions have a vertical guide groove (12) formed from the wall material of the profile and constituting the guide surface on the corner portion, while the insert (2) has a guide projection (13) accommodated in the guide groove and constituting the guide surface of the insert, the guide projection having a configuration which is approximately complementary to the configuration of the guide groove.
3. The apparatus as claimed in Claim 1 or 2, **characterised in that** the surface structure is disposed on the guide surfaces (13) of the insert (2).
4. The apparatus as claimed in any one of Claims 1-3, **characterised in that** the surface structure is formed in that the guide surface has projecting ribs or strips with interjacent depressions.

5. The apparatus as claimed in any one of Claims 1-3, characterised in that the surface structure is formed by the guide surface being granular.
- 5 6. The apparatus as claimed in any one of Claims 1-5, characterised in that the surface structure includes means for fixedly retaining the insert (2) in the upper end position thereof.

Fig. 2.

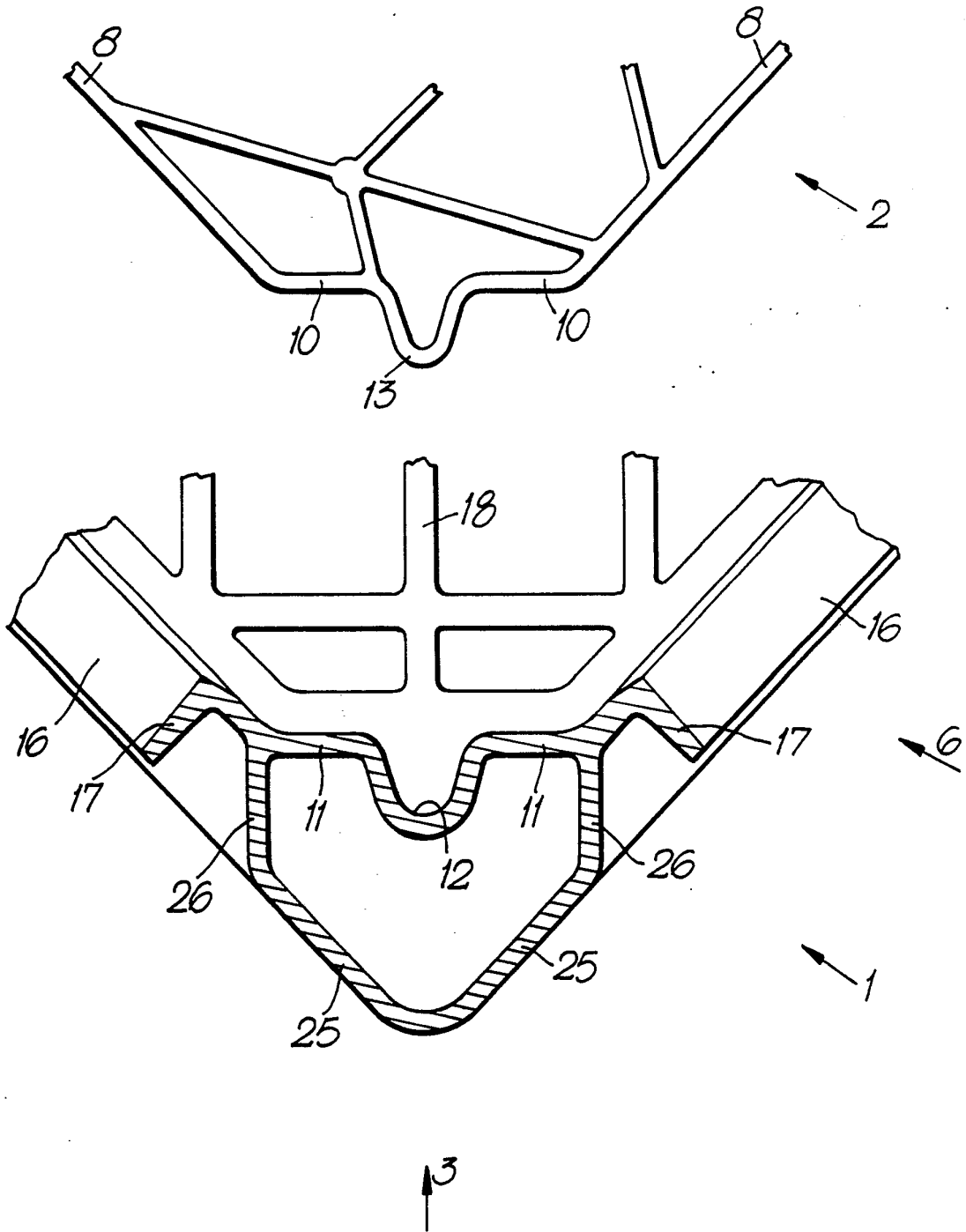

INTERNATIONAL SEARCH REPORT

International Application No **PCT/SE 90/00712**

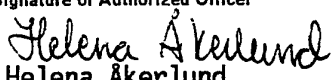
I. CLASSIFICATION OF SUBJECT MATTER (if several classification symbols apply, indicate all) ⁶		
According to International Patent Classification (IPC) or to both National Classification and IPC		
IPC5: B 65 D 25/06, 1/24		
II. FIELDS SEARCHED		
Minimum Documentation Searched ⁷		
Classification System	Classification Symbols	
IPC5	B 65 D	
Documentation Searched other than Minimum Documentation to the Extent that such Documents are Included in Fields Searched ⁸		
SE,DK,FI,NO classes as above		
III. DOCUMENTS CONSIDERED TO BE RELEVANT⁹		
Category *	Citation of Document, ¹¹ with indication, where appropriate, of the relevant passages ¹²	Relevant to Claim No. ¹³
A	SE, B, 407779 (NORPLASTA AS) 23 April 1979, see the whole document --	
A	NO, B, 135176 (NORPLASTA A/S) 15 November 1976, see the whole document --	
A	DE, A, 2152110 (NEDERLANDSE ORGANISATIE VOOR TOEGEPAST-NATUURWETENSCHAPPELIJK ONDERZOEK TEN BEHOEVE VAN NIJVERHEID, HANDEL EN VERKEER) 20 April 1972, see the whole document --	
A	US, A, 3762594 (UTZ) 2 October 1973, see the whole document --	
<p>* Special categories of cited documents:¹⁰</p> <p>"A" document defining the general state of the art which is not considered to be of particular relevance</p> <p>"E" earlier document but published on or after the international filing date</p> <p>"L" document which may throw doubts on priority claim(s) or which is cited to establish the publication date of another citation or other special reason (as specified)</p> <p>"O" document referring to an oral disclosure, use, exhibition or other means</p> <p>"P" document published prior to the international filing date but later than the priority date claimed</p> <p>"T" later document published after the international filing date or priority date and not in conflict with the application but cited to understand the principle or theory underlying the invention</p> <p>"X" document of particular relevance, the claimed invention cannot be considered novel or cannot be considered to involve an inventive step</p> <p>"Y" document of particular relevance, the claimed invention cannot be considered to involve an inventive step when the document is combined with one or more other such documents, such combination being obvious to a person skilled in the art.</p> <p>"&" document member of the same patent family</p>		
IV. CERTIFICATION		
Date of the Actual Completion of the International Search	Date of Mailing of this International Search Report	
31st January 1991	1991 -02- 06	
International Searching Authority	Signature of Authorized Officer	
SWEDISH PATENT OFFICE	 Helena Åkerlund	

III. DOCUMENTS CONSIDERED TO BE RELEVANT (CONTINUED FROM THE SECOND SHEET)		
Category *	Citation of Document, with indication, where appropriate, of the relevant passages	Relevant to Claim No
A	FI, B, 47316 (SARVIS OY) 31 July 1973, see the whole document --	
A	CH, A5, 537311 (FIRMA ALFRED STÖCKLI SÖHNE) 13 July 1973, see the whole document -- -----	

**ANNEX TO THE INTERNATIONAL SEARCH REPORT
ON INTERNATIONAL PATENT APPLICATION NO. PCT/SE 90/00712**

This annex lists the patent family members relating to the patent documents cited in the above-mentioned international search report. The members are as contained in the Swedish Patent Office EDP file on **90-12-28**. The Swedish Patent Office is in no way liable for these particulars which are merely given for the purpose of information.

Patent document cited in search report	Publication date	Patent family member(s)	Publication date
SE-B- 407779	79-04-23	SE-A- 7407126	74-12-02
NO-B- 135176	76-11-15	NONE	
DE-A- 2152110	72-04-20	BE-A- 774062 GB-A- 1342806 NL-A- 7015287	72-02-14 74-01-03 72-04-21
US-A- 3762594	73-10-02	AT-A-B- 315724 BE-A- 775051 CA-A- 972728 CH-A- 530913 FR-A-B- 2112557 GB-A- 1373115 NL-A- 7115326 US-E- RE29262	74-04-15 72-03-01 75-08-12 72-11-30 72-06-16 74-11-06 72-05-12 77-06-14
FI-B- 47316	73-07-31	NONE	
CH-A5- 537311	73-07-13	NONE	