



US 20050120482A1

(19) **United States**

(12) **Patent Application Publication**

Robie

(10) **Pub. No.: US 2005/0120482 A1**

(43) **Pub. Date: Jun. 9, 2005**

(54) **PRAYER AID**

Publication Classification

(76) Inventor: **Lynn Robie, Independence, WI (US)**

(51) **Int. Cl.⁷ A47G 9/00**

(52) **U.S. Cl. 5/639; 5/485**

Correspondence Address:
LITMAN LAW OFFICES, LTD
PO BOX 15035
CRYSTAL CITY STATION
ARLINGTON, VA 22215 (US)

(57) **ABSTRACT**

The prayer aid is a pocketed pillow or cushion that is used to hold prayer cards. The prayer aid may be disposed on the pillow's surface, in the side seams, or under a design formed on the pillow's surface. The pockets may have flaps to help conceal the pocket and to prevent the prayer card or cards from sliding out of the pocket. Both the prayer aid and the pockets on the prayer aid can take a variety of shapes and forms.

(21) Appl. No.: **10/728,747**

(22) Filed: **Dec. 8, 2003**

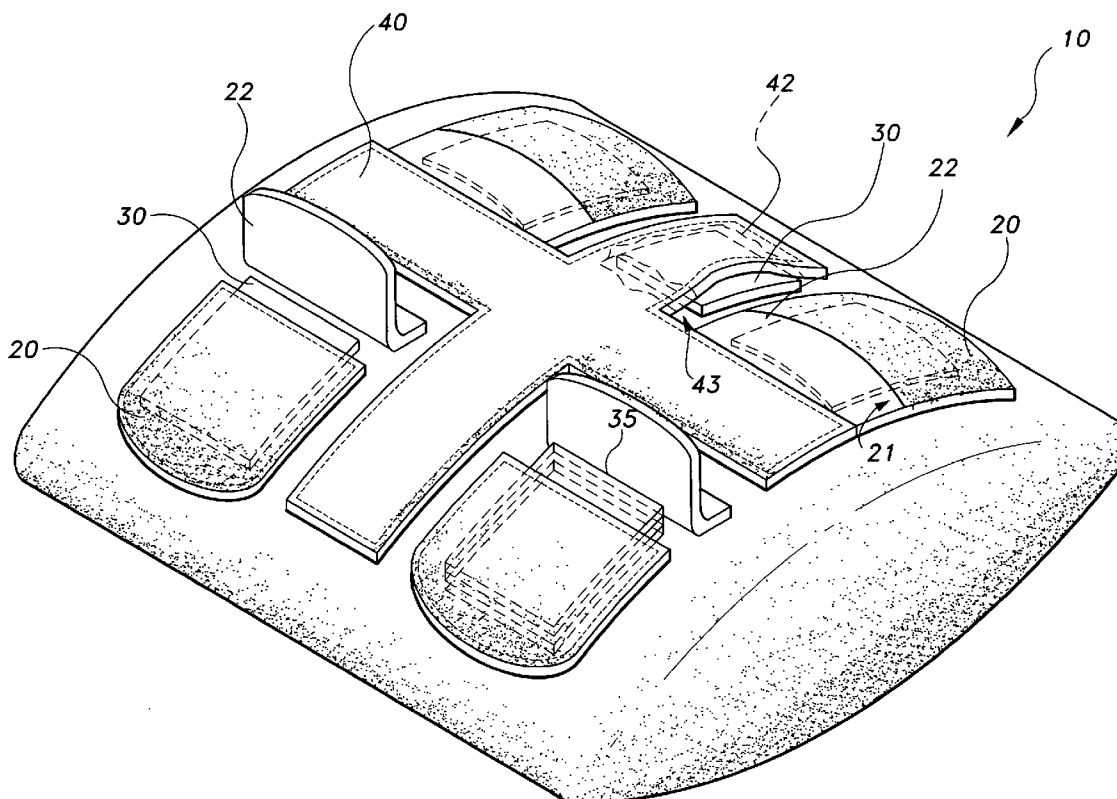

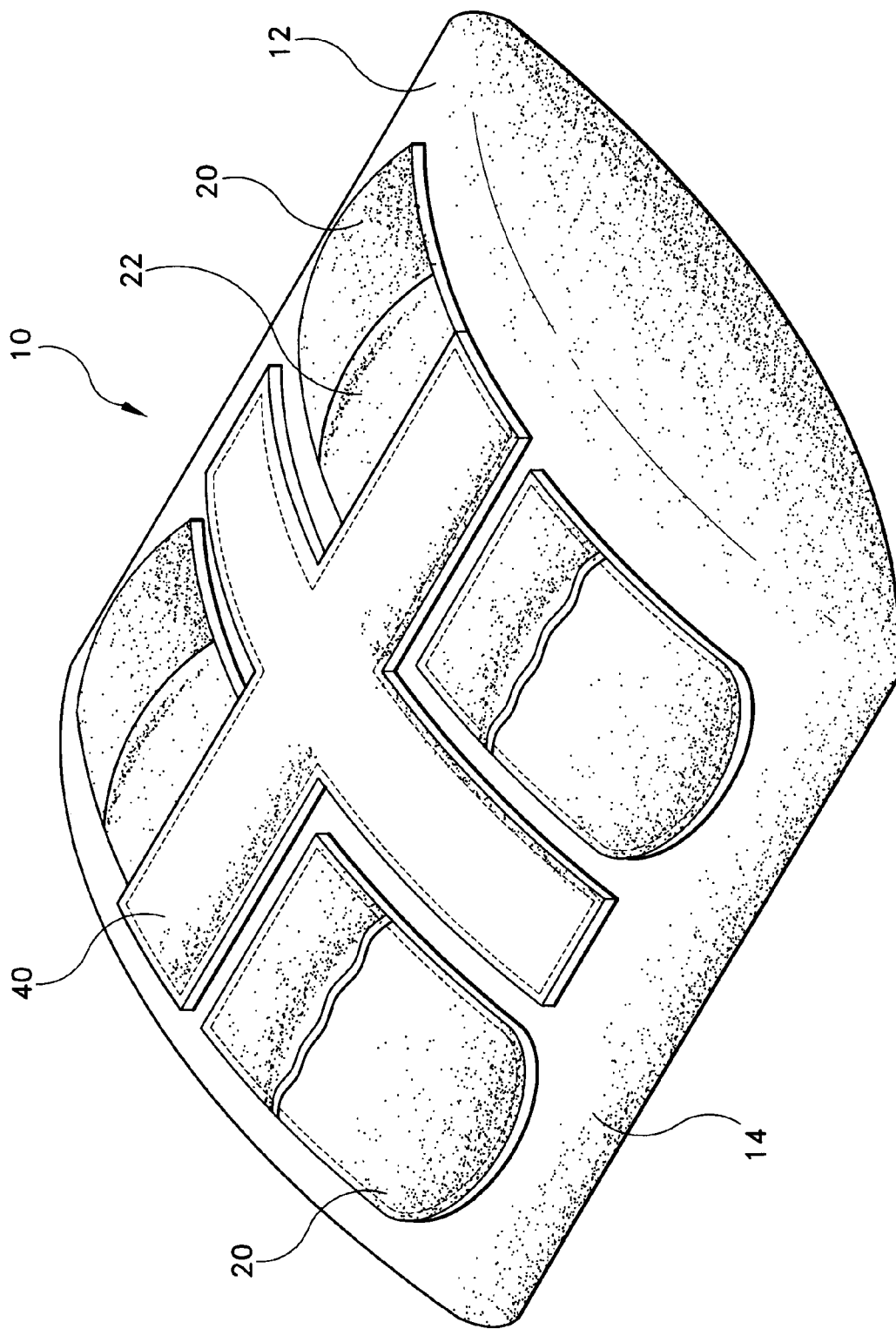

Fig. 1

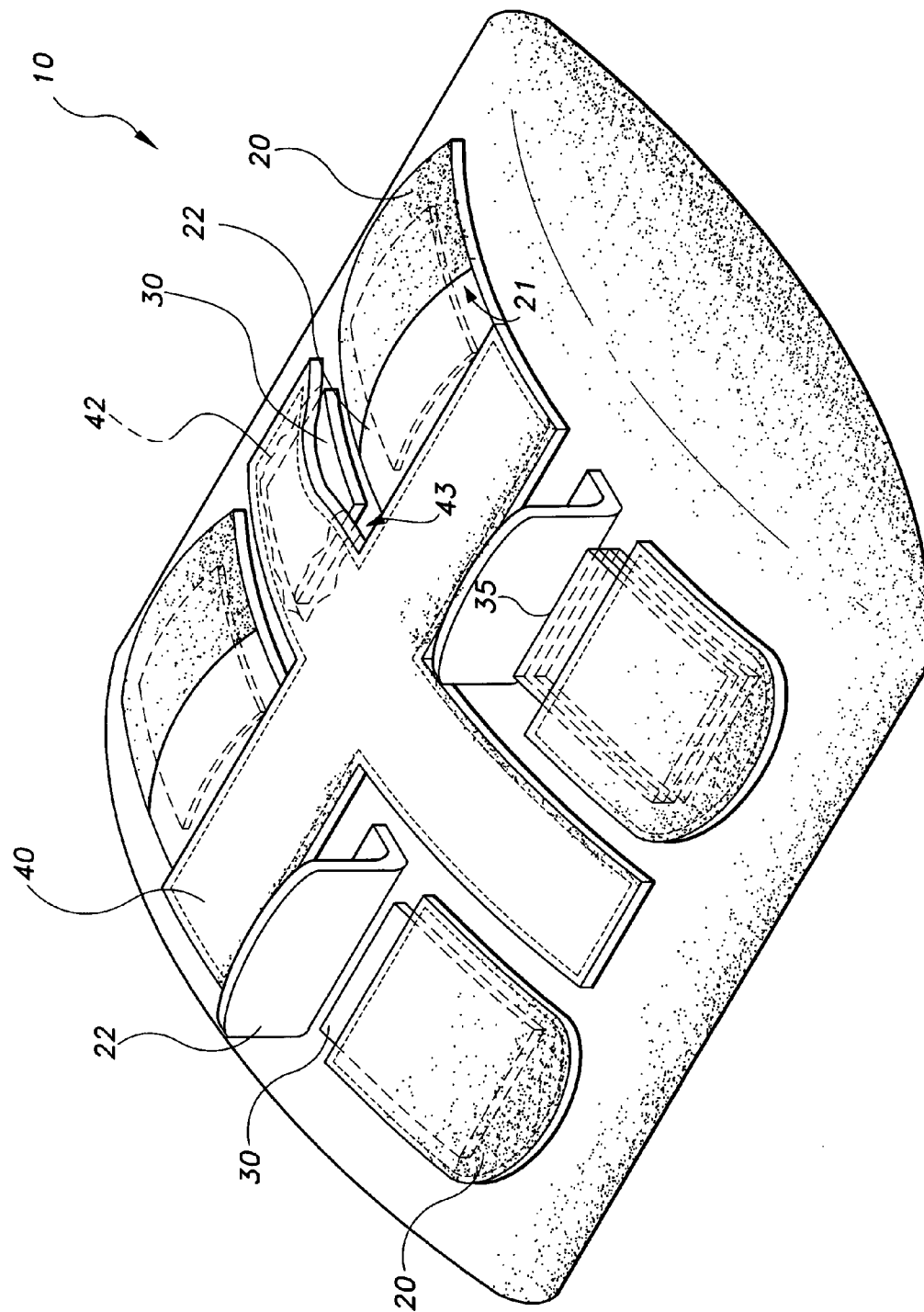

Fig. 2

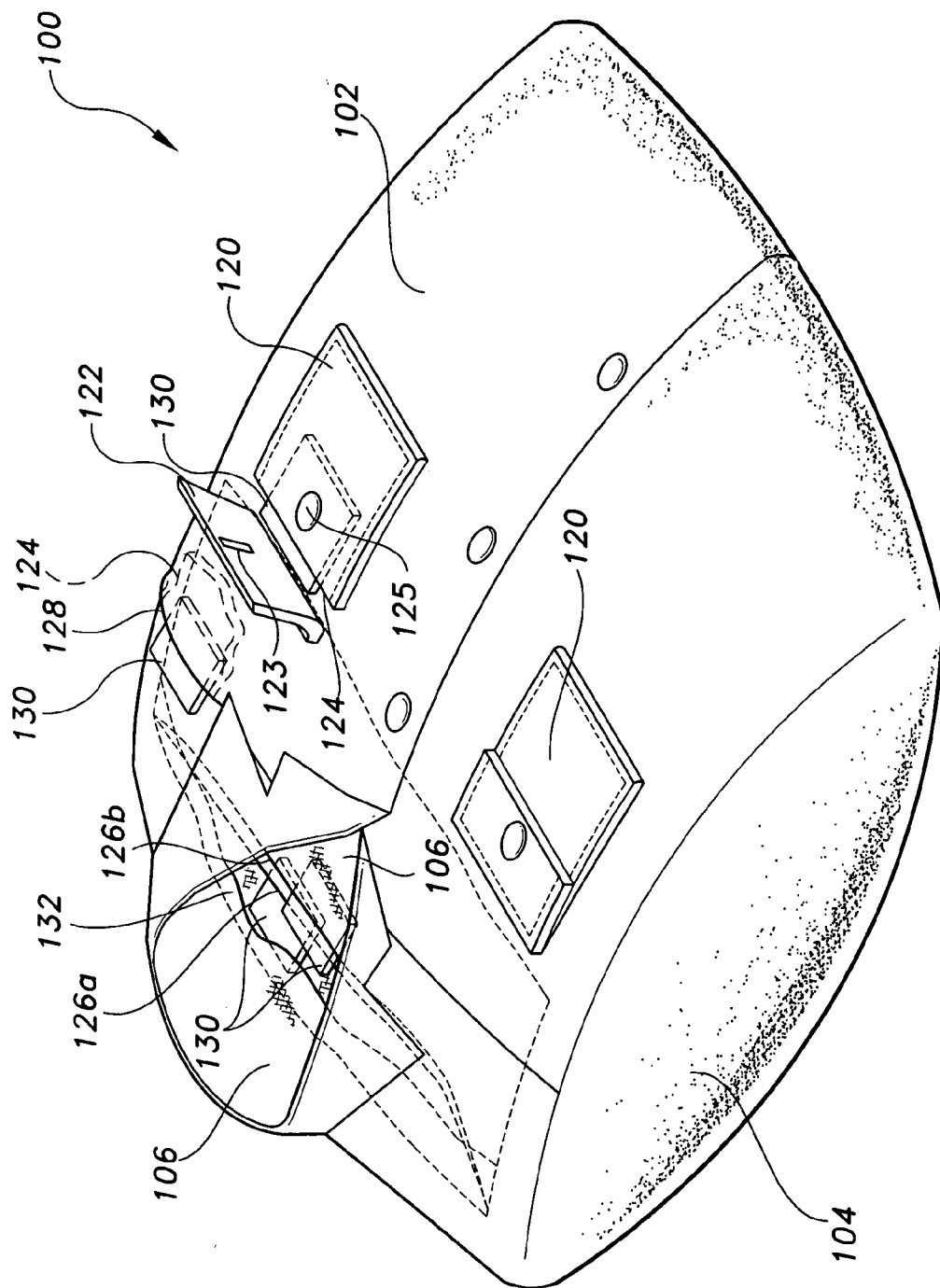

Fig. 3

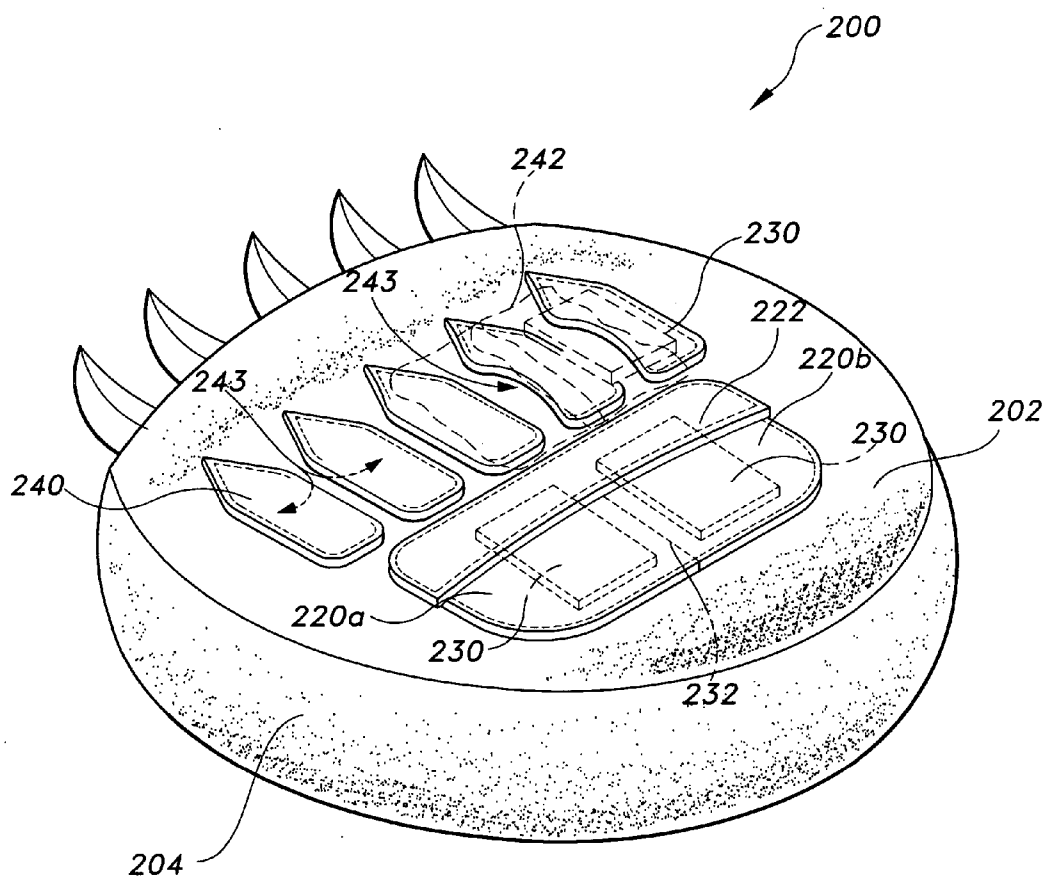

Fig. 4

PRAYER AID

BACKGROUND OF THE INVENTION

[0001] 1. Field of the Invention

[0002] The present invention relates to prayer aids, and more particularly to a cushion or pillow having a number of pockets to retain prayer cards and other religious articles.

[0003] 2. Description of the Related Art

[0004] Most religions practice some form of prayer. Prayer is practiced in a number of ways and for a variety of reasons. The act of praying can involve the use of religious and non-religious objects and be either overt or covert. Some people believe that their religion should not be belittled by ostentatious displays of prayer. Such people believe that prayer is meant to be private, out of the public's view, and that those who ostentatiously display the fact they are praying are insincere.

[0005] It therefore is not uncommon for people to hold a religious item or items, or to hide the items on their person, clothing or in their possessions, as they pray. At times, people find the best way to continue to think about a prayer is by keeping the religious items in a book, by their bed, on their body or clothing, or under their pillow. A problem with the above-mentioned ways of keeping the religious item is that the article could be misplaced, or it could fall out of the pages of a book or fall off a bed.

[0006] Some religious items, such as paper items, cannot be worn on the person. Other items are fragile, and thus can be easily ruined if worn or placed in bedding. As a result, it would be advantageous to find a way to keep the religious item out of the public's view, held in a secure place, and near one's person without being worn on the body. A number of pillows and dolls have been developed to display messages, mementos or to hold items having secular and non-secular significance.

[0007] U.S. Patent Application Publication Number 2002/0050008, published May 2, 2002, describes a tooth shaped pillow. The pillow has a hidden pocket that is covered by a flap and a drawstring pouch that is securely held within the hidden pocket. The pillow's hidden pocket or the drawstring pouch within the pocket is used to hold objects, such as baby teeth, toothpaste or loose coins. U.S. Pat. No. 5,778,468, issued to Saarela et al. on Jul. 14, 1998, describes a pillow also used as a tote. The pillow is cloud-shaped and has an elastic pocket to hold books and small toys.

[0008] U.S. Pat. No. 4,309,784, issued to Cohen on Jan. 12, 1982, describes a pillow display case. One face of a conventional pillow is overlaid with a transparent plastic sheet to form a pocket. The pocket is then filled with mementos and other objects that can be viewed from the outside.

[0009] U.S. Pat. No. 4,768,245, issued to Dutton on Sep. 6, 1988, describes a pillow having a pocket for receiving a book. The book cover and pillow are coordinated to match each other so the user can associate the pillow with the book. U.S. Pat. No. 4,853,994, issued to Ekstein on Aug. 8, 1989, describes a pillow book in which cushions form the front and back covers of the book and the pages of the book are disposed between the two cushions.

[0010] Dolls having storage capabilities or that are used to convey religious sentiment are disclosed in U.S. Pat. No. 5,324,201, issued to Friedel on Jun. 28, 1994 (a therapeutic doll having a torso cavity for holding icons and written messages to dissuade a person from carrying out vices); U.S. Pat. No. 5,059,149, issued to Stone on Oct. 22, 1991 (a stuffed animal having one or more storage compartments in its body and appendages for storing or displaying objects); and U.S. Pat. No. 6,447,363, issued to Carraway on Sep. 10, 2002 (prayer pledge doll used to promise to pray for another).

[0011] None of the above inventions and patents, taken either singly or in combination, is seen to describe the instant invention as claimed. Thus a prayer aid solving the aforementioned problems is desired.

SUMMARY OF THE INVENTION

[0012] The prayer aid is a pocketed pillow or cushion that is used to retain and conceal prayer card(s) as one prays. The prayer aid has one or several pockets placed in a variety of arrangements. The pockets on the prayer aid may be disposed on the pillow's surface, in the side seams, or under a design formed on the pillow's surface. The pockets may have flaps to help conceal the pocket and to prevent the prayer card or cards from sliding out of the pocket. Both the prayer aid and the pockets on the prayer aid can take a variety of shapes and forms.

[0013] Accordingly, it is a principal object of the invention to provide a prayer aid that has pockets to retain prayer cards as one prays.

[0014] It is another object of the invention to provide a prayer aid that allows a person to keep and conceal a prayer card.

[0015] It is a further object of the invention to provide a prayer aid that is soft and comfortable and for use as a conventional pillow.

[0016] Still another object of the invention is to provide a prayer aid in the form of a pillow having pockets and prayer cards retained in the pockets that may be formed in various designs.

[0017] It is an object of the invention to provide improved elements and arrangements thereof for the purposes described which is inexpensive, dependable and fully effective in accomplishing its intended purposes.

[0018] These and other objects of the present invention will become readily apparent upon further review of the following specification and drawings.

BRIEF DESCRIPTION OF THE DRAWINGS

[0019] **FIG. 1** is a perspective view of a prayer aid according to the present invention.

[0020] **FIG. 2** is a perspective view of the prayer aid according to the present invention with the flaps raised, showing insertion of prayer cards into the pockets.

[0021] **FIG. 3** is a perspective view of the prayer aid according to the present invention in which the pillow is configured to simulate a shirt.

[0022] FIG. 4 is a perspective view of the prayer aid according to the present invention in which the pillow is configured to simulate a bear paw.

[0023] Similar reference characters denote corresponding features consistently throughout the attached drawings.

DETAILED DESCRIPTION OF THE PREFERRED EMBODIMENTS

[0024] The present invention is a prayer aid, designated generally as **10** in FIGS. 1 and 2. The prayer aid **10** is a pocketed pillow or cushion. The prayer aid **10** is constructed as a conventional pillow **12** or cushion having an outer case or cover **14** enclosing cushioning material. The pillow **12** is filled with batting or other conventional filler or cushioning material (not shown). The prayer aid **10** shown in FIGS. 1 and 2 is generally rectangular and has a cross design **40** disposed on the cover **14**, as well as a plurality of pockets **20** and **42**. Prayer aid **10** can be made in shapes other than a rectangle, such as a triangle, a square, a circle, cylindrical etc. Surface pockets **20** are four-sided, with three sides attached to the cover **14** and the fourth side being unattached in order to form the opening **21** into the pocket.

[0025] The pockets **20** preferably have a flap **22** to cover the opening **21** of the pocket **20**. As shown in FIG. 2, flap **22** is a generally rectangular flap with one full side and at least a portion of two other sides unattached to the cover **14** so that the flap **22** can be lifted up and folded back to expose the opening **21** of the pocket **20**. Alternatively, flap **22** may have three full sides of its four sides attached to the cover **14** to make it a fixed flap instead of the hinged flap shown in FIGS. 1 and 2. Flap **22** helps to retain objects placed in the pockets **20**, such as a single prayer card **30** or a plurality of prayer cards **35**. Normally prayer card(s) **30**, **35** are smooth and as a result they slide past each other and can potentially slide out of the pockets **20**.

[0026] A second type of pocket **42** is concealed underneath the arm of the cross design **40**. Design **40** is preferably sewn to the surface of the prayer aid **10**. Pocket **42** has three sides attached to the cover **14** and a fourth side which is not attached to the cover in order to define the pocket opening **43**. Pocket **42** is placed so that the open side is formed by the material defining the cross design **40**. The remaining portion of pocket **42** is pouch-like, and is disposed between cross **40** and cover **14**.

[0027] Pockets **20** and **42** are used to conceal and retain a prayer card **30** or a deck of prayer cards **35**. The prayer card(s) **30**, **35** are largely Christian products sold commercially by the numerous Christian based organizations, such as Navigator Press (a Colorado Springs, Colo. based company) and Bridge Building Images, Inc. (based in Burlington, Vt.). Typically, a prayer card **30** displays a religious picture on one side of the card and a prayer on the opposite side of the card **30**. The cards **30**, **35** are used as a medium for individuals, both adult and children, to provide structured methods of praying. The prayer cards **35** help an individual improve their praying skills by guiding them to pray on particular topics and motivating individuals to pray effectively.

[0028] The prayer aid **10** is described for use with Christian religions, but it can also be used for other religions as well. One specific example of prayer cards designed for children are called T.H.U.M.B. prayer cards. The T.H.U.M.B. acronym stands for Tribal, Hindu, Unreligious, Muslim, and Buddhist. Each card has prayers written about

each identified group and encourages the child to pray for the group cited on the cards. The prayer aid **10** preferably holds and conceals a prayer card **30**. However, the prayer aid **10** should not be limited to retain a prayer card **30** or a deck of prayer cards **35** alone. The pockets **20** and **42** can hold other religious items as well, such as a rosary, a crucifix, a bible, etc., or non-religious items of sentimental value, such as children's drawing or pictures of family or friends.

[0029] The prayer aid **10** provides a creative way to pray by allowing the user to hold and conceal a prayer card **30** in a comfortable object that also has everyday use. An added benefit of using prayer aid **10** is to permit the user to hold a prayer card **30** in a secure place out of the public's view. The prayer aid **10** allows the owner to pray without disclosing the fact that they are praying or that they are holding a prayer card **30**. Also, the prayer aid **10** permits the user to keep a prayer card **30** in their possession without being worn on their clothing or even on their body. By possessing the prayer aid **10** the user is able to meditate on praying and/or keep the spirit of the loved one as represented in the picture or writing near them. The prayer aid **10** is designed to be held but it can also be used for sleeping and kneeling purposes. Often the practice of sleeping or resting with one's head against the pillow **12** containing one or more prayer cards **30** and **35** provides the user with a comforting feeling that is akin to praying in one's sleep.

[0030] FIG. 3 shows a prayer aid **100** in which the pillow **102** is configured to simulate a shirt. More particularly, the pillow **102** may be configured to resemble an occupational shirt that can be made to represent different occupations, such as a military camouflage shirt, a hospital worker's scrubs, a construction worker's shirt, etc. Pillow **102** has a number of pockets disposed on its surface and in its seams. Pillow **102** has an outer casing including outer pillow cover **104** and inner lining **106**. Two pockets **120** are disposed on outer pillow cover **104**. Pockets **120** are four-sided, having three sides attached to the outer cover **104** of the pillow **102** and one side being left open to define pocket opening **121**. Pocket **120** has a flap **122** disposed above pocket opening **121**. Flap **122** is a hinged flap, folding down to cover pocket opening **121** and up to expose pocket opening **121**. Optionally, a buttonhole **123** is formed in the center of flap **122** to receive button **125** to secure flap **122** to pocket **120**; otherwise, the flap **122** may simply lie over the pocket opening **121**. If desired, flaps **122** can be secured to pocket **120** by means other than buttons, such as hook and loop closures, snaps or zippers.

[0031] A second type of pocket is disposed attached to outer pillow cover **104**, namely seam pocket **124** disposed above left breast pocket **120**. Seam pocket **124** has three attached sides forming a pouch and an open side defining pocket opening **128**. The side forming pocket opening **128** is designed to simulate a seam extending between the shirt collar and the side of the shirt where a shirt sleeve would normally be attached.

[0032] Pillow **100** also displays a third pocket type, a layered pocket **126** formed on and by the inner lining **106**. The layered pocket **126** in FIG. 3 shows two pockets; one pocket **126b** lies on top of another pocket **126a**, however the layered pocket could be three or more pockets disposed on top of each other. Layered pockets **126a** and **126b** are disposed in the neck opening of the prayer aid **100**, however it can be located anywhere on the surface of the prayer aid **100**. Layered pockets **126a** and **126b** are made by folding and sewing one large piece of fabric in layers, or by sewing

a number of fabrics on top of each other to form layers. Layered pockets **126a** and **126b** can be made to have a flap **132** that covers its open side or it can be made to have no flap at all. Pockets **120**, **124**, **126a**, **126b** all hold a prayer card **130**, a deck of prayer cards, pictures or drawings.

[0033] FIG. 4 shows a prayer aid **200** in which the pillow **202** is configured as a bear paw. The bear paw pillow **202** has pockets **242** located underneath each of its five pads **240** and pockets **220a** and **220b** simulating the sole of the bear paw **200**. Each pocket **242** has four sides, including three sides attached to the pillow cover **204** and one unattached side that forms an opening **243** for the pocket **242** and three closed sides forming a pouch pocket.

[0034] Sole pocket **220a** and sole pocket **220b** are formed from one pocket that has been divided into two adjacent pockets by a seam **232**. The sole of the bear paw could be made as one undivided pocket or into numerous pockets divided by several seams. A flap **222** covers the openings of adjacent pockets **220a** and **220b** and forms the upper portion of the sole on the bear paw pillow **200** design. Flap **222** is fixed, in that three of four sides of the flap are secured to the prayer aid **10**, **100**, **200** surface. Sole pocket **220** could be designed without the flap **222** and still faithfully represent the sole design of the bear paw pillow **200**. All the pockets are designed to hold a prayer card **230** or a set of prayer cards.

[0035] The pockets disposed on and within the prayer aid **10**, **100** and **200**, respectively, can be surface pockets **20**, **120**, **220a**, **220b** or concealed pockets such as pockets **42**, **126a**, **126b**, **242** as shown in FIGS. 2, 3 and 4, respectively or seam pocket **124** shown in FIG. 3. The pockets are preferably opaque since they are designed to conceal the prayer card **30**. The pockets are generally made of non-elastic materials such as fabric, but if desired and feasible elastic fabric may be used to construct the pockets. The pockets can be placed anywhere and in any position on the prayer aid **10**, **100**, **200** they can also take a number of sizes, shapes and forms. For example, the pockets can be circular, two-sided or multi-sided.

[0036] The number of pockets disposed on the prayer aid **10**, **100**, **200** can range in number from two to several. The pockets can be individual and separate, be adjacent each other in a side by side design, or disposed on top of each other in a layered design. The pockets can also be designed to have a flap or not have a flap. If flaps are used they may be hinged **22**, **122** as shown in FIGS. 2 and 3, respectively, or fixed **222** as shown in FIG. 4.

[0037] It is to be understood that the present invention is not limited to the embodiments described above, but encompasses any and all embodiments within the scope of the following claims.

1-17. (canceled)

18. A prayer cushion and aid, comprising:

- a pillow having an outer casing and an inner filling;
 - said inner filling being a soft resilient material;
 - said outer casing having a predetermined shape for providing an aesthetically appealing appearance;
- wherein said inner filling maintaining the shape of the outer casing;
- an ornamental design attached to the outer casing of said pillow;

- a plurality of pockets disposed in said outer casing, each one of said plurality of pockets defining an opening;

- wherein at least one of said plurality of pockets is defined between said ornamental design and the outer cover;

- whereby said ornamental design is aesthetically appealing, and fosters a feeling of comfort; and

- a plurality of prayer cards;

- wherein at least one prayer card disposed in at least one of said plurality of pockets.

19. The prayer cushion and aid according to claim 18, wherein said at least one pocket further comprises at least two pockets;

- wherein said two pockets overlap between said outer casing and said inner filling.

20. The prayer cushion and aid according to claim 18, further comprising:

- a flap disposed above at least one pocket of said plurality of pockets;

- said flap being movable between a closed position and an open position; and

- means for securing said flap in the closed position;

- wherein when in said closed position, said flap covers the opening of said at least one pocket; and when in said open position, said flap exposes the opening of said at least one pocket;

- whereby access to the pocket is provided and prevented by said flap.

21. The prayer cushion and aid according to claim 20, further comprising:

- a button attached to said outer casing, adjacent to the opening of said at least one pocket, and said flap including a buttonhole defined therein;

- wherein said button matingly engages the buttonhole for securing said flap in said closed position.

22. The prayer cushion and aid according to claim 18, wherein said ornamental design includes a cross, said cross is attached to said outer casing,

- whereby at least one pocket of said plurality of pockets is defined between the cross and the outer casing.

23. The prayer cushion and aid according to claim 18, said pillow further includes at least one side edge;

- wherein said ornamental design of said outer casing is a simulated shirt; said simulated shirt includes at least a collar, at least one seam extending between said collar and said at least one side edge, and at least one breast pocket;

- said collar having an inner lining and defining a neck opening, said inner lining of said neck opening defining at least one pocket of said plurality of pockets;

- said at least one pocket of said plurality of pockets is disposed along said at least one seam, and

- said at least one breast pocket defining at least one pocket of said plurality of pockets.

24. The prayer cushion and aid according to claim 18, wherein said ornamental design simulates a bear paw; said

bear paw having patches attached to said outer casing, and configured to resemble a plurality of toe pads and a sole pad;

wherein each of said plurality of toe pads and said sole pad defines at least one pocket of said plurality of pockets;

whereby each of said plurality of toe pad pockets and said sole pad pocket stores said at least one prayer card therein.

* * * * *