



(12) **EUROPEAN PATENT APPLICATION**

(88) Date of publication A3:
17.01.2018 Bulletin 2018/03

(51) Int Cl.:
G01R 15/20 (2006.01) G01R 19/00 (2006.01)
G01R 21/08 (2006.01)

(43) Date of publication A2:
15.11.2017 Bulletin 2017/46

(21) Application number: **17172922.1**

(22) Date of filing: **10.09.2014**

(84) Designated Contracting States:
AL AT BE BG CH CY CZ DE DK EE ES FI FR GB GR HR HU IE IS IT LI LT LU LV MC MK MT NL NO PL PT RO RS SE SI SK SM TR

(71) Applicant: **Osaka City University**
Osaka-shi, Osaka 558-8585 (JP)

(72) Inventor: **TSUJIMOTO, Hiroaki**
Osaka-shi, Osaka 558-8585 (JP)

(30) Priority: **17.10.2013 JP 2013216852**

(74) Representative: **EIP**
EIP Europe LLP
Fairfax House
15 Fulwood Place
London WC1V 6HU (GB)

(62) Document number(s) of the earlier application(s) in accordance with Art. 76 EPC:
14853530.5 / 3 059 596

(54) **ELECTRIC CURRENT MEASUREMENT APPARATUS**

(57) Disclosed is an electric current measurement apparatus to measure a current flowing in a wire. The electric current measurement apparatus comprises a first magnetic element; a second magnetic element; a first current source capable of supplying a first alternating current to the first magnetic element; a second current source capable of supplying a second alternating current to the second magnetic element, a phase of the second alternating current being deviated from a phase of the first alternating current; a first lowpass filter configured to pass a low frequency component of an output from the first magnetic element; and a second low pass filter configured to pass a low frequency component of an output from the second magnetic element. The electric current measurement apparatus also comprises an operator configured to calculate a square root of a sum of squares of an output from the first low pass filter and an output from the second low pass filter, and / or an arc tangent value of the output from the first low pass filter and the output from the second low pass filter.

FIG.14

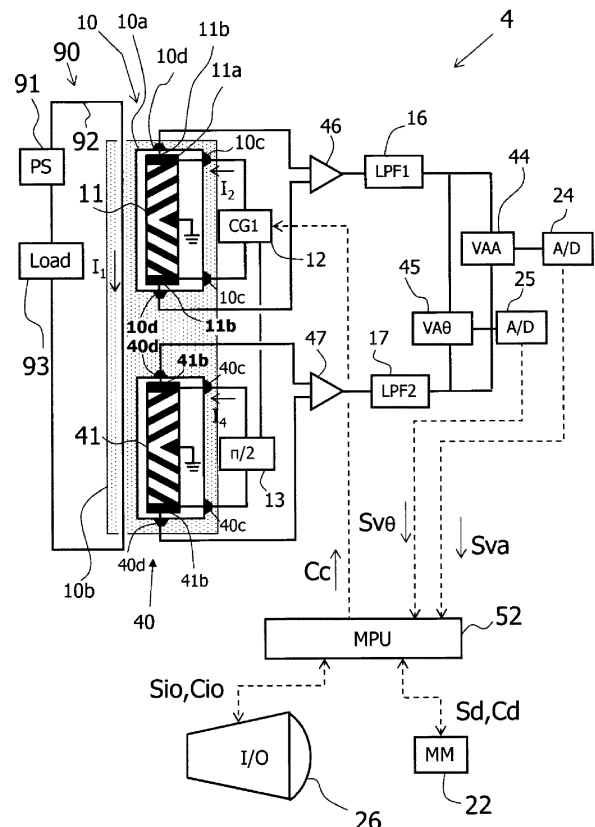



EUROPEAN SEARCH REPORT

Application Number
EP 17 17 2922

5

10

15

20

25

30

35

40

45

50

55

DOCUMENTS CONSIDERED TO BE RELEVANT			
Category	Citation of document with indication, where appropriate, of relevant passages	Relevant to claim	CLASSIFICATION OF THE APPLICATION (IPC)
A	US 2009/206831 A1 (FERMON CLAUDE [FR] ET AL) 20 August 2009 (2009-08-20) * figures 1, 2, 4 *	1	INV. G01R15/20 G01R19/00 G01R21/08
A	US 2011/006753 A1 (YU KONGHUI [JP] ET AL) 13 January 2011 (2011-01-13) * figures 1, 2 *	1	
A	GB 2 438 057 A (ROBERTSON PAUL ANDREW [GB]) 14 November 2007 (2007-11-14) * figures 1, 3, 7 *	1	
A	US 2009/230955 A1 (KEJIK PAVEL [CH] ET AL) 17 September 2009 (2009-09-17) * figure 4a *	1	
A	US 7 294 995 B1 (TEKTRONIX INC [US]) 13 November 2007 (2007-11-13) * figures 1, 8 *	1	
A	DE 36 42 478 A1 (BITZER BERTHOLD [DE]; VOSS JUERGEN DR [DE]) 23 June 1988 (1988-06-23) * figure 1 *	1	TECHNICAL FIELDS SEARCHED (IPC) G01R
The present search report has been drawn up for all claims			
Place of search Munich		Date of completion of the search 4 December 2017	Examiner Agerbaek, Thomas
CATEGORY OF CITED DOCUMENTS X : particularly relevant if taken alone Y : particularly relevant if combined with another document of the same category A : technological background O : non-written disclosure P : intermediate document		T : theory or principle underlying the invention E : earlier patent document, but published on, or after the filing date D : document cited in the application L : document cited for other reasons & : member of the same patent family, corresponding document	

EPO FORM 1503 03.02 (P04C01)

ANNEX TO THE EUROPEAN SEARCH REPORT
ON EUROPEAN PATENT APPLICATION NO.

EP 17 17 2922

5 This annex lists the patent family members relating to the patent documents cited in the above-mentioned European search report.
The members are as contained in the European Patent Office EDP file on
The European Patent Office is in no way liable for these particulars which are merely given for the purpose of information.

04-12-2017

Patent document cited in search report	Publication date	Patent family member(s)	Publication date
US 2009206831 A1	20-08-2009	EP 1991862 A1	19-11-2008
		JP 4776696 B2	21-09-2011
		JP 2009527745 A	30-07-2009
		US 2009206831 A1	20-08-2009
		WO 2007095971 A1	30-08-2007

US 2011006753 A1	13-01-2011	CN 101949965 A	19-01-2011
		JP 2011017618 A	27-01-2011
		US 2011006753 A1	13-01-2011

GB 2438057 A	14-11-2007	GB 2438057 A	14-11-2007
		GB 2461207 A	30-12-2009
		GB 2461437 A	06-01-2010

US 2009230955 A1	17-09-2009	CN 101228453 A	23-07-2008
		EP 1746430 A1	24-01-2007
		EP 1907872 A1	09-04-2008
		JP 2009503443 A	29-01-2009
		US 2009230955 A1	17-09-2009
WO 2007010378 A1	25-01-2007		

US 7294995 B1	13-11-2007	CN 101438172 A	20-05-2009
		EP 2016427 A2	21-01-2009
		JP 4753323 B2	24-08-2011
		JP 2009536742 A	15-10-2009
		US 2007257657 A1	08-11-2007
		WO 2007131186 A2	15-11-2007

DE 3642478 A1	23-06-1988	NONE	
