

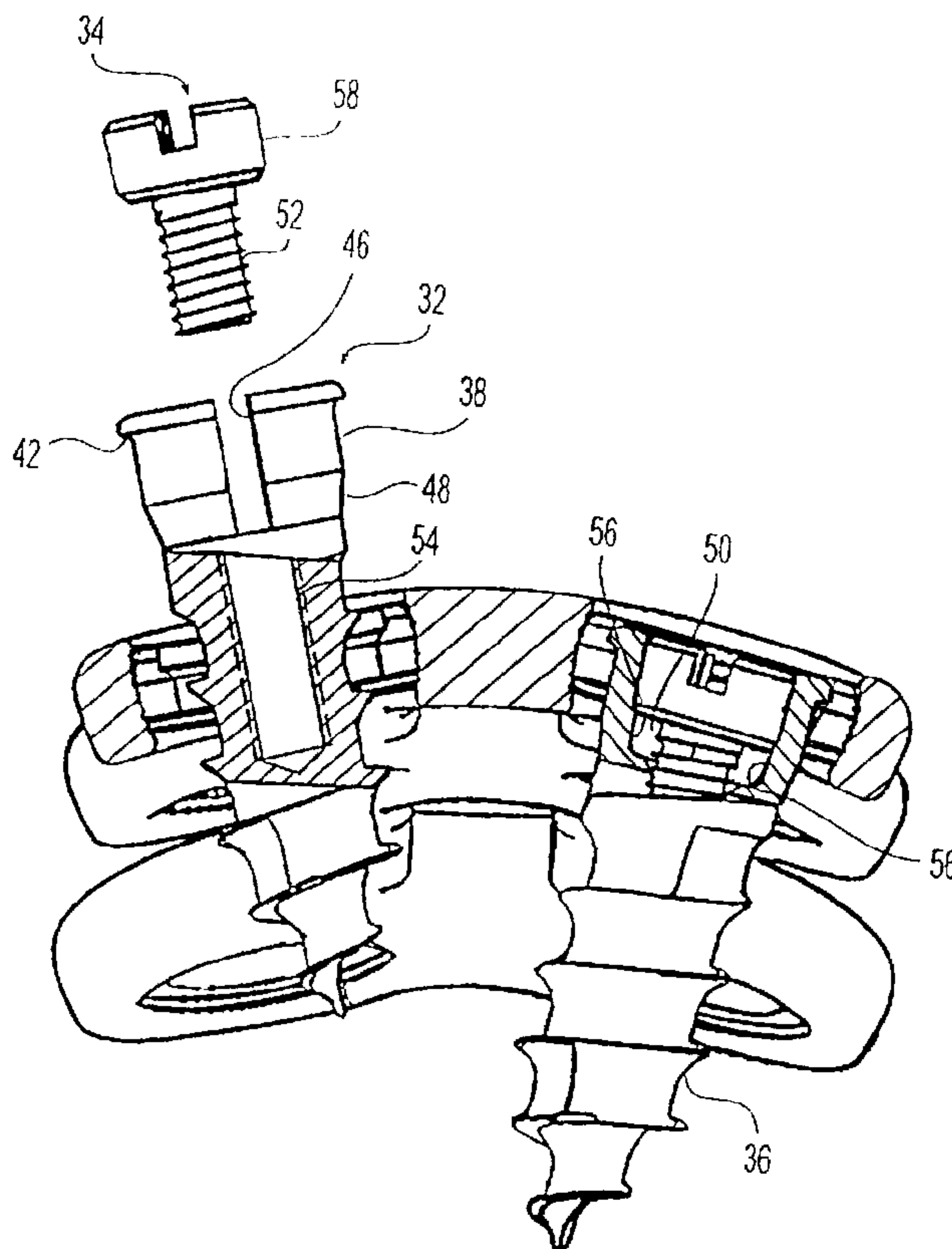

(86) Date de dépôt PCT/PCT Filing Date: 2001/03/28  
 (87) Date publication PCT/PCT Publication Date: 2001/10/25  
 (45) Date de délivrance/Issue Date: 2007/01/09  
 (85) Entrée phase nationale/National Entry: 2002/10/03  
 (86) N° demande PCT/PCT Application No.: CH 2001/000190  
 (87) N° publication PCT/PCT Publication No.: 2001/078615  
 (30) Priorité/Priority: 2000/04/19 (US09/453,911)

(51) Cl.Int./Int.Cl. *A61B 17/80* (2006.01),  
*A61B 17/70* (2006.01)  
 (72) Inventeurs/Inventors:  
BRACE, MICHAEL, US;  
EMCH, HANSJUERG, US  
 (73) Propriétaire/Owner:  
SYNTHES (U.S.A.), US  
 (74) Agent: OSLER, HOSKIN & HARCOURT LLP

(54) Titre : ENSEMBLE DE FIXATION D'OS  
 (54) Title: BONE FIXATION ASSEMBLY



(57) Abrégé/Abstract:

The present invention relates to a bone fixation assembly for securing a fixation device (10), such as a bone plate, to bone. The assembly includes the fixation device (10), a bushing (14), a fastening screw (32), and a locking screw (34). The bushing (14) is seated within a through hole (12) in the fixation device (10) and can rotate within the through hole (12) and has a sidewall (20) with a bore (24). The sidewall (20) has at least one slot (28; 28a) for allowing outward expansion of the sidewall (20) against the through hole (12) to thereby lock the bushing (14) at a selected angle relative to the axis of the through hole (12). The fastening screw (32)

**(57) Abrégé(suite)/Abstract(continued):**

has a threaded shaft (36) for insertion through the bore (24) of the bushing (14) and threads into bone to secure the bushing (14) and fixation device (10) to bone. The head (38) of the fastening screw (32) fits in the bushing (14) and includes a radial wall (44) and open end defining a recess (50). The radial side wall (44) has at least one slit (46) for allowing outward expansion of the radial wall (44) thereby outwardly expanding the sidewall (20) of the bushing (14). The locking screw (34) has a body that threads in the head (38) of the fastening screw (32) to thereby outwardly expand the radial wall (44) of the fastening screw (32).

## (12) INTERNATIONAL APPLICATION PUBLISHED UNDER THE PATENT COOPERATION TREATY (PCT)

(19) World Intellectual Property Organization  
International Bureau(43) International Publication Date  
25 October 2001 (25.10.2001)

PCT

(10) International Publication Number  
WO 01/78615 A1

- (51) International Patent Classification<sup>7</sup>: A61B 17/80
- (21) International Application Number: PCT/CH01/00190
- (22) International Filing Date: 28 March 2001 (28.03.2001)
- (25) Filing Language: English
- (26) Publication Language: English
- (30) Priority Data:  
09/453,911 19 April 2000 (19.04.2000) US
- (71) Applicant (for all designated States except CA, US): SYNTHES AG CHUR [CH/CH]; Grabenstrasse 15, CH-7002 Chur (CH).
- (71) Applicant (for CA only): SYNTHES (U.S.A.) [US/US]; 1690 Russell Road, P.O. Box 1766, Paoli, PA 19301-1222 (US).
- (72) Inventors; and
- (75) Inventors/Applicants (for US only): BRACE, Michael [US/US]; 1611 Bridle Path Drive, Lansdale, PA 19446 (US). EMCH, Hansjuerg [CH/US]; 310 South 12th Street, Philadelphia, PA 19107 (US).
- (74) Agent: LUSUARDI, Werther; Dr. Lusuardi AG, Kreuzbühlstrasse 8, CH-8008 Zürich (CH).
- (81) Designated States (national): AU, CA, JP, NZ, US, ZA.
- (84) Designated States (regional): European patent (AT, BE, CH, CY, DE, DK, ES, FI, FR, GB, GR, IE, IT, LU, MC, NL, PT, SE, TR).
- Published:  
— with international search report  
— before the expiration of the time limit for amending the claims and to be republished in the event of receipt of amendments

[Continued on next page]

(54) Title: BONE FIXATION ASSEMBLY

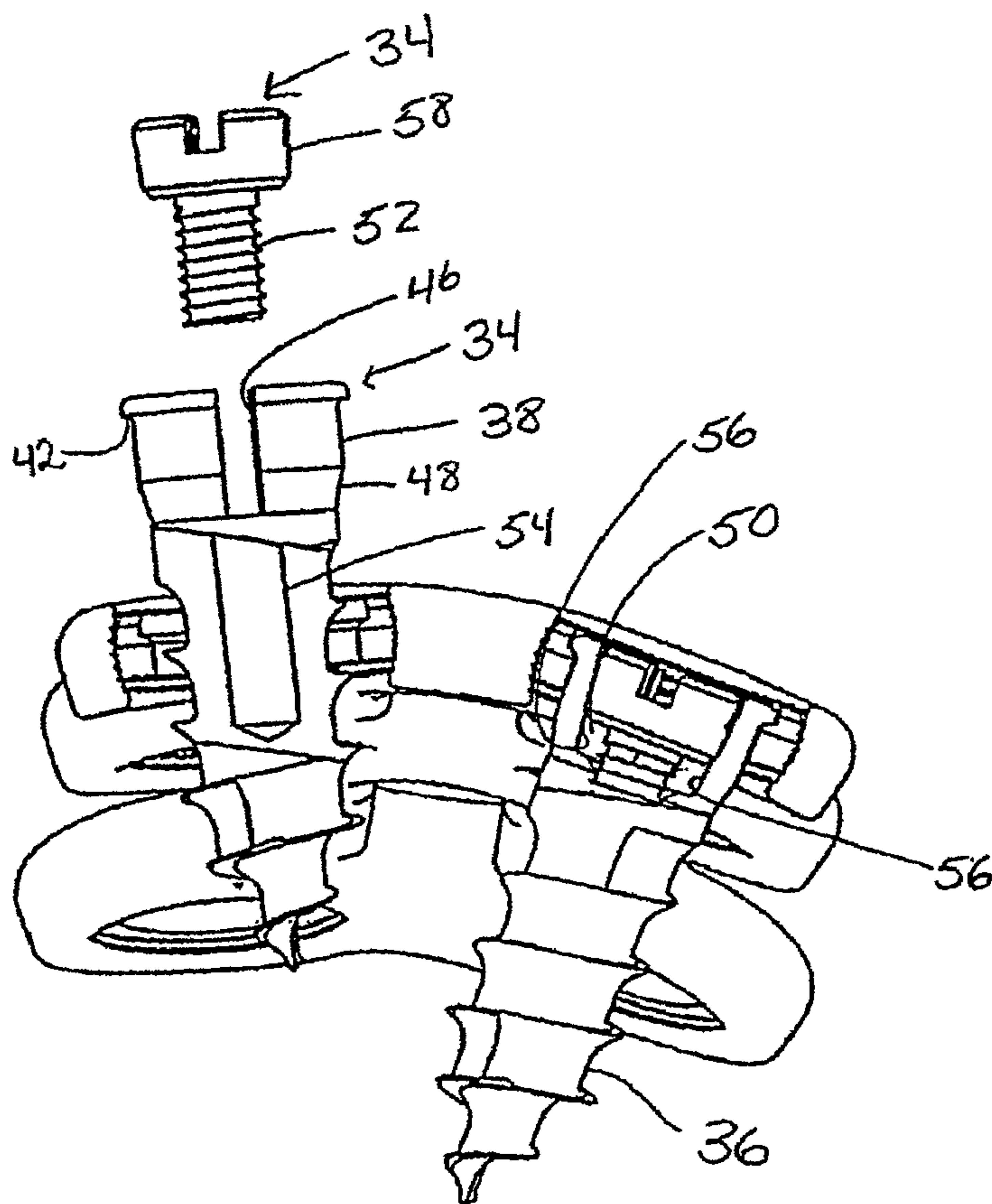

(57) Abstract: The present invention relates to a bone fixation assembly for securing a fixation device (10), such as a bone plate, to bone. The assembly includes the fixation device (10), a bushing (14), a fastening screw (32), and a locking screw (34). The bushing (14) is seated within a through hole (12) in the fixation device (10) and can rotate within the through hole (12) and has a sidewall (20) with a bore (24). The sidewall (20) has at least one slot (28; 28a) for allowing outward expansion of the sidewall (20) against the through hole (12) to thereby lock the bushing (14) at a selected angle relative to the axis of the through hole (12). The fastening screw (32) has a threaded shaft (36) for insertion through the bore (24) of the bushing (14) and threads into bone to secure the bushing (14) and fixation device (10) to bone. The head (38) of the fastening screw (32) fits in the bushing (14) and includes a radial wall (44) and open end defining a recess (50). The radial side wall (44) has at least one slit (46) for allowing outward expansion of the radial wall (44) thereby outwardly expanding the sidewall (20) of the bushing (14). The locking screw (34) has a body that threads in the head (38) of the fastening screw (32) to thereby outwardly expand the radial wall (44) of the fastening screw (32).

WO 01/78615 A1

**WO 01/78615 A1**

---



*For two-letter codes and other abbreviations, refer to the "Guidance Notes on Codes and Abbreviations" appearing at the beginning of each regular issue of the PCT Gazette.*



**BONE FIXATION ASSEMBLY**

5

The present invention is directed to a bone fixation assembly, and in particular to a bushing and screw assembly for securing a fixation device to bone.

10

Orthopaedic fixation devices, both internal and external, are frequently coupled to bone by the use of fasteners such as screws or pins. For example, bone plates can be secured to bone with bone screws inserted through plate holes. Securing the screws to the plate provides a fixed angle relationship between the plate and screw and reduces the incidence of loosening. One method of securing the screw to the plate involves the use of so-called "expansion-head screws." U.S. Patent No. 4,484,570 discloses an expansion-head screw with a head that has a recess, the walls of which contain a number of slits.

15

After the expansion-head screw is inserted into bone through a hole in the fixation device, a locking screw is inserted into the recess to expand the walls of the recess to thereby lock the screw to the fixation device.

20

In addition to securing the screw to the fixation device, it is also often desirable to insert the screws at an angle relative to the fixation device selected by the surgeon. The prior art discloses a number of these so-called "polyaxial" systems, most of which utilize a bushing located in a hole in the fixation device to provide for angulation of the screw relative to the fixation device. For example, U.S. Patent No. 5,954,722 discloses a polyaxial locking plate that includes a plate hole having a bushing rotatable within the hole.

25

As a screw is being inserted into bone through the bushing and plate hole, a threaded head of the screw engages a threaded internal surface of the bushing to expand the bushing against the wall of the plate hole, thereby locking the screw at the desired angular orientation with respect to the plate.

30

The present invention relates to an improved bone fixation assembly that allows for a surgeon-selected angle of a fastening screw relative to the fixation device and locking of the fastening screw once the screw is at the desired orientation.

35

The present invention relates to a bone fixation assembly for securing a fixation device, such as a bone plate, to bone. The assembly includes a fixation device, a bushing, a fastening screw, and a locking screw. The bushing has a sidewall with an exterior surface configured and dimensioned for polyaxial rotation within the through hole of the fixation device and an interior surface which defines a bore that extends through the upper

and lower surfaces of the bushing. The sidewall has at least one slot for allowing outward  
5 expansion of the sidewall against the through hole of the fixation device to thereby lock the  
bushing at a selected angle relative to the axis of the through hole of the fixation device.

The fastening screw has a threaded shaft configured and dimensioned for insertion  
through the bore of the bushing and threadably insertable into bone to secure the bushing  
and fixation device to bone. The head of the fastening screw is configured and  
10 dimensioned for insertion in the bushing and includes a radial wall and open end defining  
a recess. The radial side wall has at least one slit for allowing outward expansion of the  
radial wall thereby outwardly expanding the sidewall of the bushing. The locking screw  
has a threaded body threadably received in the head of the fastening screw to thereby  
15 outwardly expand the radial wall of the fastening screw.

The bushing can have a substantially frustospherical shape with the bore extending  
through the central axis of the bushing, perpendicular to the upper and lower surfaces. In  
an exemplary embodiment, the bushing has an annular shoulder and the head of the  
fastening screw is flush with the upper surface of the bushing when the head of the  
20 fastening screw rests against the shoulder. The fastening screw can be provided with a  
lip protruding from the radial wall which rests on the annular shoulder when the fastening  
screw is threaded into the bone.

In one embodiment, the sidewall of the bushing includes a plurality of slots  
extending from the upper surface of the bushing. Furthermore, one of the slots can extend  
25 from the upper surface completely through the lower surface. In order to further increase  
the security of the bushing within the through hole, the exterior surface of the sidewall of  
the bushing and/or the walls of the through hole of the fixation device can be provided with  
ridges.

In order to eliminate the need to tap a drilled hole, the fastening screw can be a  
30 self-tapping screw. The fastening screw could also be a self-drilling screw. In an  
exemplary embodiment, the head of the fastening screw includes a tapered portion  
proximal to the threaded shaft.

In one embodiment, the recess of the fastening screw has a bottom surface with a  
35 threaded hole for threadably receiving at least a portion of the threaded body of the locking  
screw. The locking screw can have a tapered end. Additionally, the radial wall of the head  
of the fastening screw can have a matching tapered inner surface.

The present invention also relates to a method for securing a fixation device having  
5 a through hole to bone. A fastening screw is inserted through a bushing located in the  
through hole of a fixation device. The fastening screw is then threaded into a bone. After  
the threading step is completed, the fastening screw is locked to the bushing and fixation  
device. The fastening screw can be inserted through the bushing at a surgeon-selected  
10 orientation relative to the fixation device. The fastening screw head is preferably expanded  
against the bushing to thereby lock the bushing to the fixation device. A locking screw can  
be inserted into a recess in the fastening screw head to cause the expansion.

Preferred features of the present invention are disclosed in the accompanying  
15 drawings, wherein similar reference characters denote similar elements throughout the  
several views, and wherein:

FIG. 1 shows a top view of a bone plate with four plate holes, each plate hole  
having a bushing according to the present invention.

FIG. 2 shows a sectional view through line 1-1 of FIG. 1.

20 FIG. 3 shows a top view of the bushing of FIGS. 1 and 2.

FIG. 4 shows a sectional view through line 3-3 of FIG. 3.

FIG. 5 shows a perspective view of the bushing of FIGS. 1-4.

FIG. 6 shows a perspective view of a bone fixation assembly according to the  
present invention with a portion of the fastening screw shown in cross section to illustrate  
25 insertion of the locking screw.

FIG. 7 shows a top view of the fastening screw of FIG. 6 prior to insertion of the  
locking screw.

FIG. 8 shows a top view of the locking screw of FIG. 6.

30 FIG. 9 shows a sectional view of a bone plate having a second embodiment of the  
bushing according to the present invention.

FIG. 10 shows a section view with a drill inserted in one of the plate holes.

FIG. 11 shows a sectional view with the fastening screws being inserted into the  
bushings.

35 FIG. 12 shows a sectional view with the locking screws inserted into the fastening  
screws.



For convenience, the same or equivalent elements in the various embodiments of the invention illustrated in the drawings have been identified with the same reference numerals. Further, in the description that follows, any reference to either orientation or direction is intended primarily for the convenience of description and is not intended in any way to limit the scope of the present invention thereto.

FIGS. 1 and 2 show a bone fixation device 10 having through holes 12 for receiving a fastener to secure device 10 to bone. Although device 10 is shown as a bone plate, device 10 can be any suitable internal or external fixation device. Examples of such devices include an external fixator, a clamp for a spinal rod, and the like. Each of through holes 12 has a bushing 14.

As best seen in FIGS. 3-5, bushing 14 has an upper surface 16, a lower surface 18, and a sidewall 20. Sidewall 20 has an exterior surface 22 configured and dimensioned for polyaxial rotation within through hole 12. As a result and as described in more detail below, a fastener inserted through a bore 24, which is defined by an interior surface 26 of bushing 14 and extends through both upper and lower surfaces 16, 18, can be inserted at a wide variety of orientations relative to device 10. In an exemplary embodiment, bushing 14 has a frustospherical shape. Alternatively, bushing 14 can have a frustoconical shape. With either shape, bore 24 can extend through the central longitudinal axis perpendicular to the parallel upper and lower surfaces 16, 18.

Bushing 14 includes slots 28 located on sidewall 20. Slots 28 allow sidewall 20 to expand outwardly against through hole 12. This outward expansion locks bushing 14 at the selected orientation relative to the axis of through hole 12. In order to enhance the locking effect upon expansion, exterior surface 22 of sidewall 20 and/or the periphery of through holes 12 can be provided with ridges 30. Ridges 30 provide an additional mechanism to resist motion of bushing 14 relative to device 10 once sidewall 20 has expanded outwardly. Although bushing 14 is shown having four slots, any number of slots, including one, can be used as long as the chosen number of slots provides for outward expansion of sidewall 20. As shown in FIG. 5, slot 28a extends from upper surface 16 through lower surface 18 while the rest of slots 28 do not extend through to lower surface 18. Slots 28 all extend from upper surface 16 of bushing 14. However, as shown in FIG. 9, slots 28 can extend from both upper and lower surfaces 16, 18. Although slots 28 of FIG. 9 extend in an alternating pattern, other patterns can be used.



As shown in FIG. 6, the bone fixation assembly according to the present invention also includes a fastening screw 32 and a locking screw 34. Fastening screw 32 has a threaded shaft 36 that inserts through bore 24 of bushing 14 and is threaded into bone to secure bushing 14 and device 10 to the bone. Fastening screw 32 can be self-tapping to eliminate the need to pre-thread the hole made in the bone. Further, fastening screw 32 can be self-drilling to also eliminate the need to pre-drill the hole. A head 38 of fastening screw 32 substantially sits within bushing 14 when fastening screw 32 has been threaded into the bone. In an exemplary embodiment, bore 24 has an annular shoulder 40 (FIG. 4) so that head 38 is flush with upper surface 16 of bushing 14 when head 38 rests against shoulder 40. This results in a low profile for the fixation assembly according to the present invention. Head 38 can be provided with a lip 42 protruding from radial wall 44. Lip 42 rests against shoulder 40 when fastening screw 32 has been threaded into the bone to further reduce the profile.

Radial wall 44 includes at least one slit 46 to enable outward expansion of radial wall 44. Thus, when head 38 is set within bore 24 of bushing 14, outward expansion of radial wall 44 of fastening screw 32 causes outward expansion of sidewall 20 of bushing 14. Fastening screw 32 can include a tapered portion 48 proximal threaded shaft 36 to maximize the expanding effect as fastening screw 32 is threaded into bone through bore 24 of bushing 14.

As head 38 of fastening screw 32 is open-ended at its top, the open end and radial wall 44 define a recess 50 into which locking screw 34 is inserted to outwardly expand radial wall 44. Locking screw 34 has a threaded body 52 that is received in a threaded blind hole 54 in fastening screw 32. Radial wall 44 of head 38 fastening screw 32 has a tapered inner surface 56 that cooperates with tapered end 58 of locking screw 34 so that as locking screw 34 is threaded into blind hole 54, tapered end 58 urges radial wall 44 outward.

In use, bone fixation device 10 is placed against bone (FIG. 9). If fastening screw is not self-drilling, a hole is drilled through bone at the desired orientation with respect to device 10 (FIG. 10). This is achieved by rotating bushing 14 within through hole 12. Fastening screw 32 is inserted through bushing 14 and threaded into bone to secure device 10 to bone (FIG. 11). Head 38 can be provided with a mechanism for mating with a driver for threading into bone. For example, FIG. 7 shows that slots 28 are formed in a pattern that allows slots 28 to receive a blade of a driver for insertion into bone.

After fastening screw 32 is threaded into bone, locking screw 34 is then inserted  
5 into recess 50. As locking screw 34 is threaded into threaded blind hole 54, tapered end  
58 of locking screw 34 pushes against radial wall 44 of fastening screw 32 to urge outward  
expansion of radial wall 44. This outward expansion of radial wall in turn causes outward  
expansion of sidewall 20 of bushing 14, thereby locking fastening screw 32, bushing 14,  
and device 10 to bone as a rigid construct. Because the locking of fastening screw 32  
10 occurs after fastening screw 32 is threaded into bone, it is easier to insert fastening screw  
32 into bone than some prior art designs, which result in simultaneous insertion and  
locking. Furthermore, because head 38 is physically deformed during the locking step (as  
opposed to just physical deformation of the bushing) the assembly according to the  
15 present invention improves interlocking between bushing 14 and fastening screw 32 to  
help ensure loosening does not occur with time.

While various descriptions of the present invention are described above, it should  
be understood that the various features can be used singly or in any combination thereof.  
Therefore, this invention is not to be limited to only the specifically preferred embodiments  
20 depicted herein.

Further, it should be understood that variations and modifications within the spirit  
and scope of the invention may occur to those skilled in the art to which the invention  
pertains. Accordingly, all expedient modifications readily attainable by one versed in the  
art from the disclosure set forth herein that are within the scope of the present invention  
25 are to be included as further embodiments of the present invention. The scope of the  
present invention is accordingly defined as set forth in the appended claims.

30

35

The Claims

1. A bone fixation assembly comprising:
  - (a) a fixation device having a through hole;
  - (b) a bushing having:
    - (i) upper and lower surfaces;
    - (ii) a sidewall with an exterior surface configured and dimensioned for polyaxial rotation within the through hole of the fixation device and an interior surface which defines a bore that extends through the upper and lower surfaces; and
      - (iii) at least one slot located on the sidewall for allowing outward expansion of the sidewall against the through hole of the fixation device to thereby lock the bushing at a selected angle relative to the axis of the through hole of the fixation device;
    - (c) a fastening screw having:
      - (i) a threaded shaft configured and dimensioned for insertion through the bore of the bushing and threadably insertable into bone to secure the bushing and fixation device to bone;
      - (ii) a head configured and dimensioned for insertion in the bushing and including a radial wall and open end defining a recess; and
        - (iii) at least one slit located on the radial wall for allowing outward expansion of the radial wall thereby outwardly expanding the sidewall of the bushing; and
      - (d) a locking screw having a threaded body threadably received in the head of the fastening screw to thereby outwardly expand the radial wall of the fastening screw.
2. The bone fixation assembly of claim 1 wherein the fixation device is a bone plate.
3. The bone fixation assembly of claim 1 wherein the bushing has a substantially frustospherical shape with a central longitudinal axis.
4. The bone fixation assembly of claim 3 wherein the bore extends through the central axis of the bushing and is perpendicular to the upper and lower surfaces.



5. The bone fixation assembly of claim 1 wherein the bore of the bushing has an annular shoulder and the head of the fastening screw is flush with the upper surface of the bushing when the head of the fastening screw rests against the shoulder.

6. The bone fixation assembly of claim 5 wherein the head of the fastening screw has a lip protruding from the radial wall.

7. The bone fixation assembly of claim 1 wherein the at least one slot includes a plurality of slots extending from the upper surface of the bushing.

8. The bone fixation assembly of claim 7 wherein one of the plurality of slots extends from the upper surface through the lower surface.

9. The bone fixation assembly of claim 1 wherein the exterior surface of the sidewall of the bushing includes ridges.

10. The bone fixation assembly of claim 1 wherein the through hole of the fixation device includes ridges.

11. The bone fixation assembly of claim 1 wherein the fastening screw is a self-tapping screw.

12. The bone fixation assembly of claim 1 wherein the fastening screw is a self-drilling screw.

13. The bone fixation assembly of claim 1 wherein the head of the fastening screw includes a tapered portion proximal to the threaded shaft.

14. The bone fixation assembly of claim 1 wherein the radial wall of the head of the fastening screw has a tapered inner surface.

15. The bone fixation assembly of claim 1 wherein the locking screw has a tapered end.

16. The bone fixation assembly of claim 1 wherein the recess of the fastening screw has a bottom surface having a threaded hole for

threadably receiving at least a portion of the threaded body of the locking screw.

17. Use of a fastening screw for securing a bone plate having a through hole to bone, wherein the bone plate comprises a bushing located in the through hole and wherein the fastening screw comprises:

(a) a threaded shaft configured and dimensioned for insertion through the bore of the bushing and threadably insertable into bone to secure the bushing and bone plate to bone; and

(b) a head configured and dimensioned for receiving a locking screw suitable for causing outward expansion of the head against the bushing to thereby lock the bushing to the bone plate.

18. The use according to claim 17 wherein the fastening screw is suitable for insertion through the bushing at a surgeon-selected orientation relative to the bone plate.

19. The use according to claim 17 wherein the fastening screw is a self-tapping screw.

20. The use according to claim 17 wherein the fastening screw is a self-drilling screw.

21. The use according to claim 17 wherein the fastening screw has a head portion configured and dimensioned to prevent its extension through the hole, and a shaft portion, configured and dimensioned for insertion through the hole.

22. The use according to claim 21 wherein the fastening screw is configured and dimensioned when it is inserted through the bore of the bushing, the shaft portion extends through the hole and the head portion is flush with a top surface of the bone plate.

23. The use according to claim 17 wherein the fastening screw is suitable for insertion in situ.

24. Use of a bone engaging member for securing a fixation device having a through hole to bone, wherein:

(a) the fixation device comprises a bushing located in the through hole; and

(b) the bone engaging member comprises:

(i) a shaft portion configured and dimensioned for insertion into the bushing, the through hole from one side of the fixation device to the other side of the fixation device and threading into a bone; and

(ii) a head configured and dimensioned for receiving a locking screw suitable for causing outward expansion of the head against the bushing to thereby lock the bushing to the fixation device.

25. The use according to claim 24 wherein the bone engaging member is suitable for insertion through the bushing at a surgeon-selected orientation relative to the fixation device.

26. The use according to claim 24 wherein the fixation device is a bone plate.

27. The use according to claim 24 wherein the bone engaging member is a self tapping screw.

28. The use according to claim 24 wherein the bone engaging member is a self-drilling screw.

29. Use of a fastening screw for securing a fixation device having a through hole to bone, wherein:

(a) the fixation device comprises a bushing located in the through hole; and

(b) the fastening screw is suitable for threadable insertion through the bushing and into bone and comprises a head configured and



dimensioned for outward expansion against the bushing to thereby lock the bushing to the fixation device.

30. The use according to claim 29 wherein the fastening screw is suitable for insertion through the bushing at a surgeon-selected orientation relative to the fixation device.

31. The use according to claim 29 wherein the fastening screw head has a recess for receiving a locking screw.

32. The use according to claim 29 wherein the fixation device is a bone plate.

33. The use according to claim 29 wherein the fastening screw is a self-tapping screw.

34. The use according to claim 29 wherein the fastening screw is a self-drilling screw.

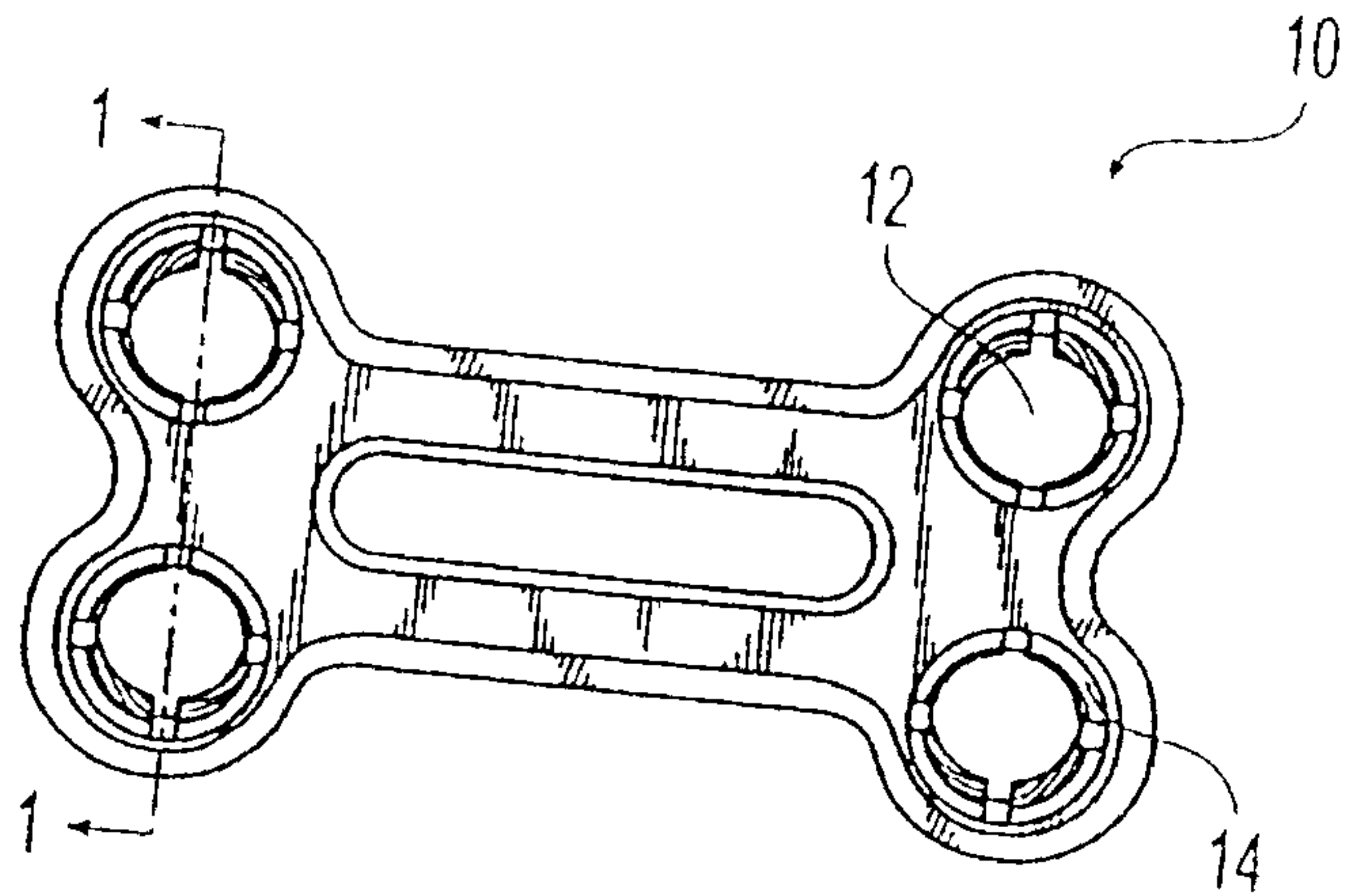

Fig. 1

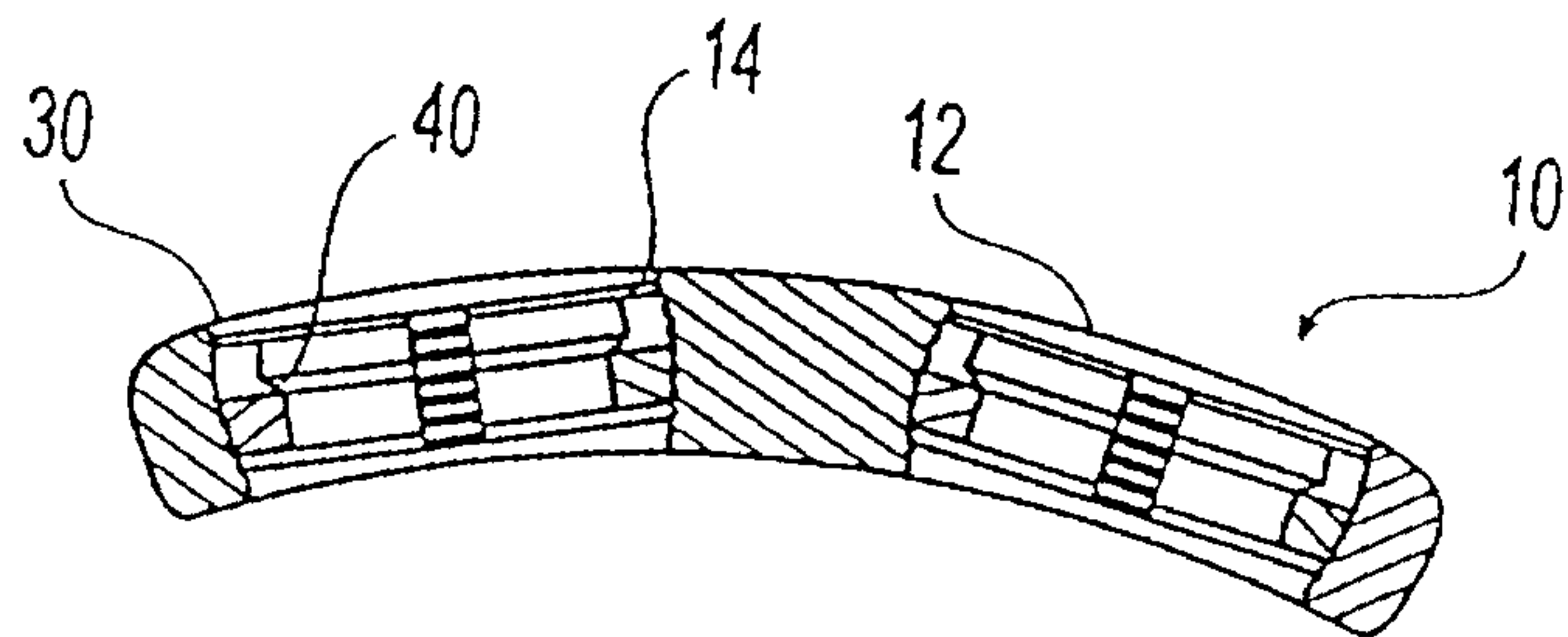

Fig. 2

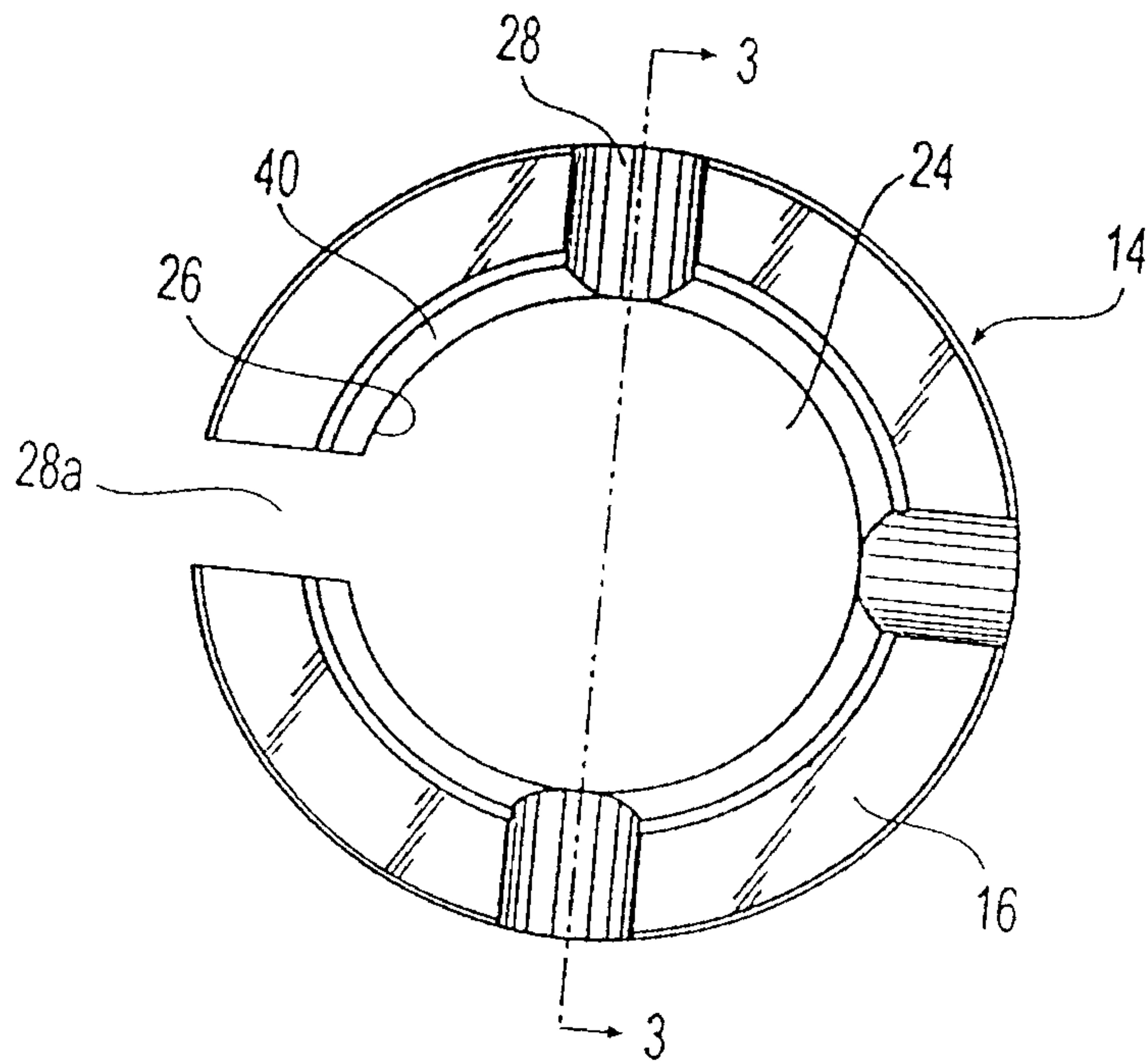
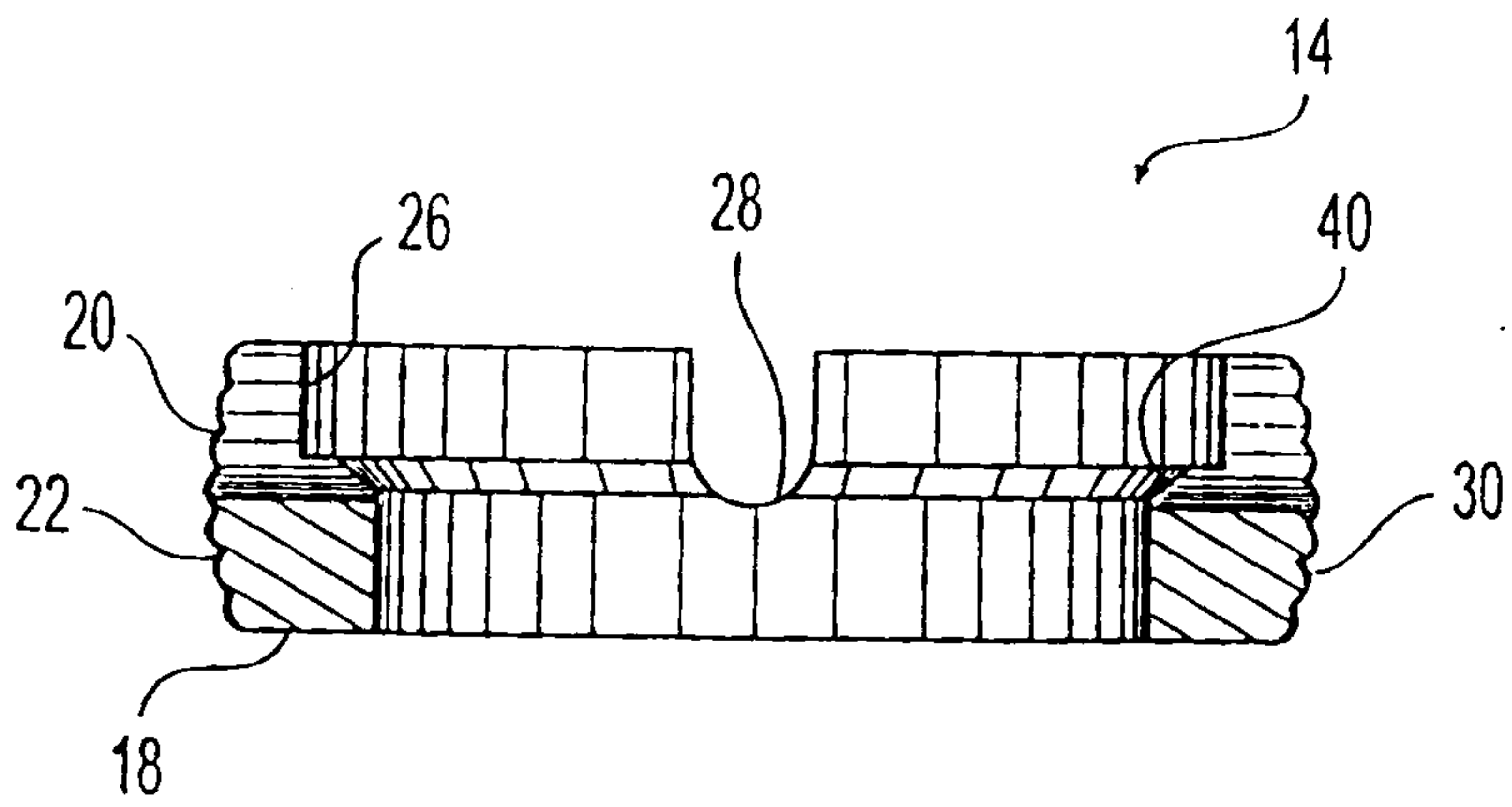
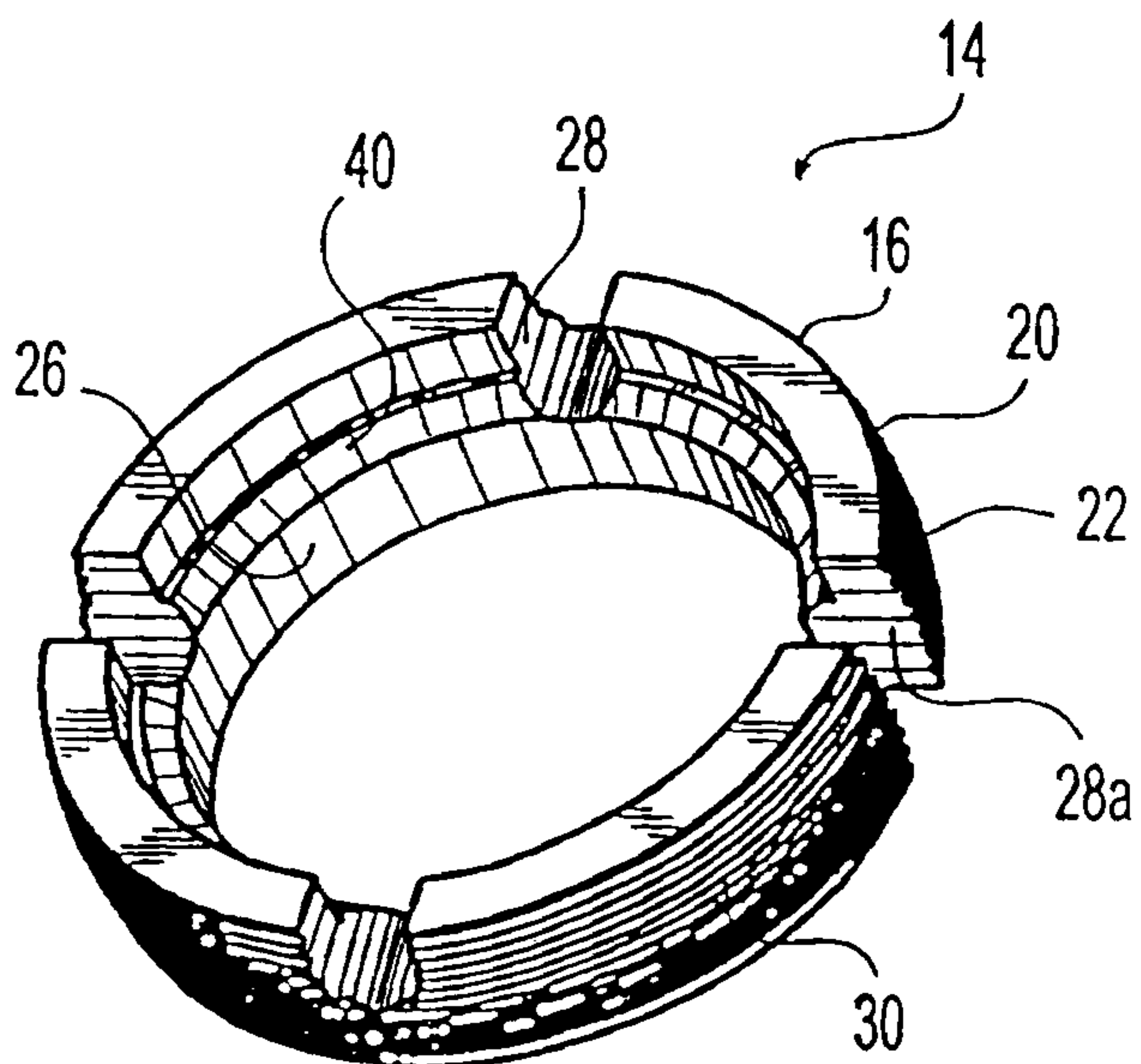

Fig. 3

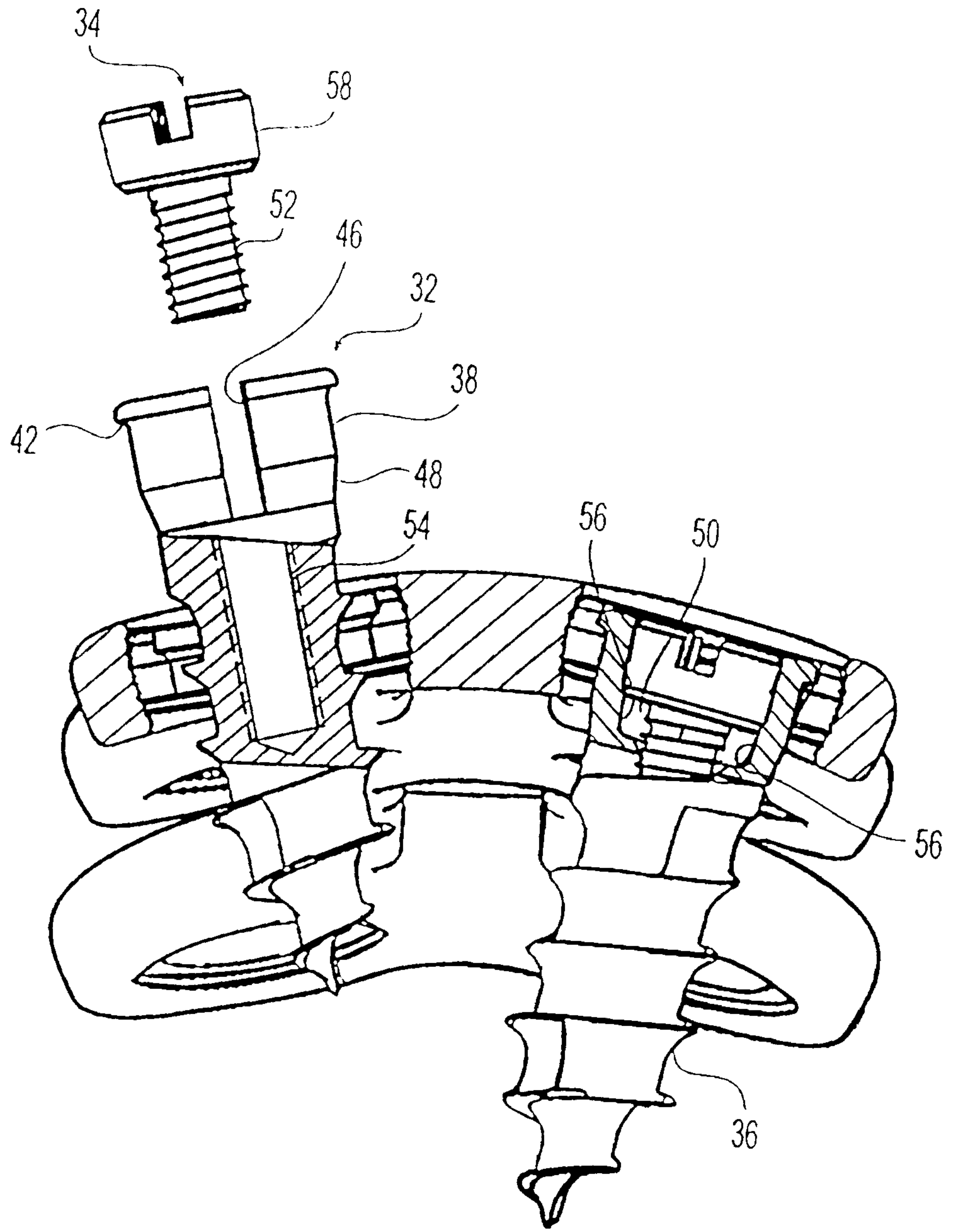

*Fig. 4*

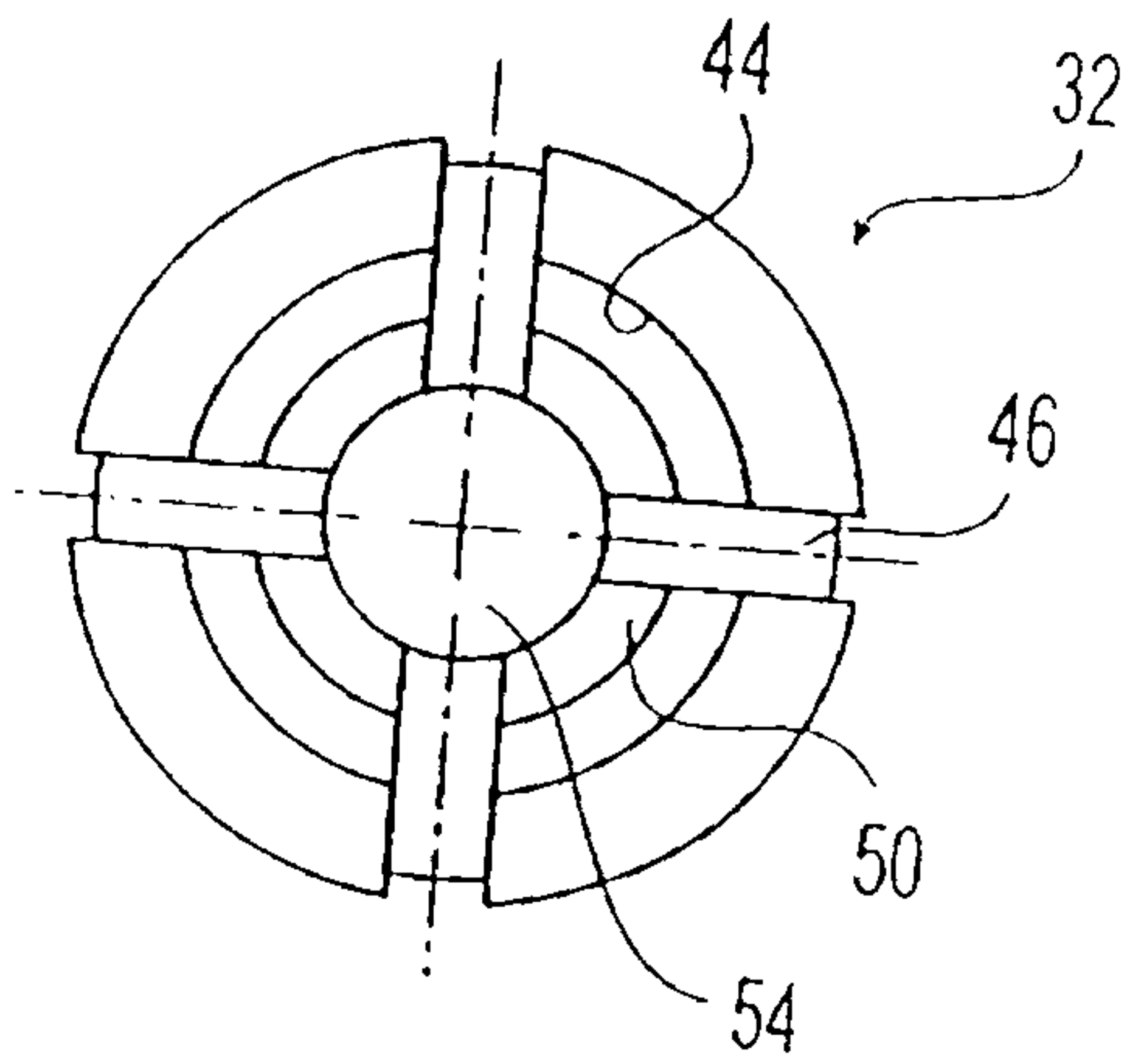

*Fig. 5*

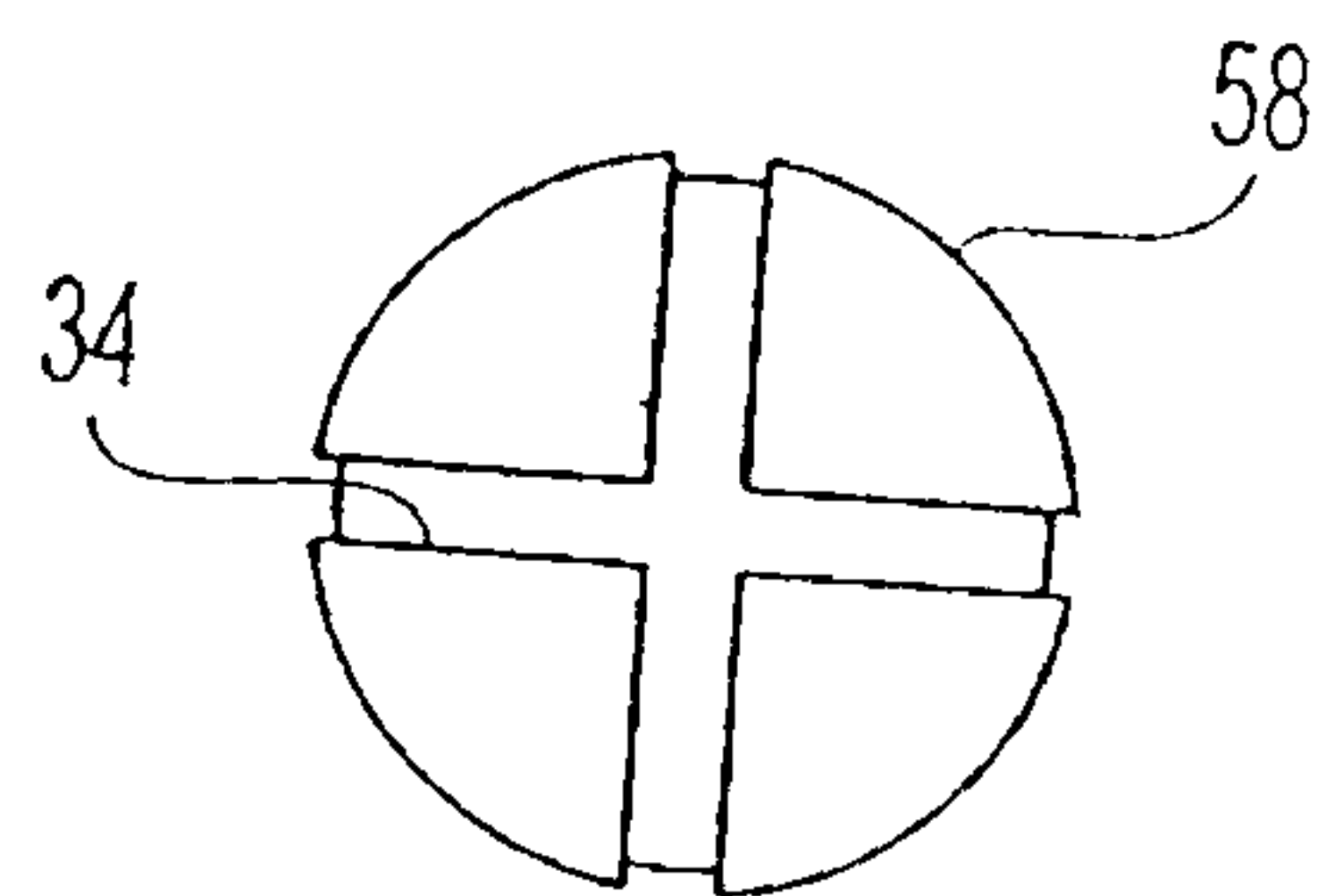



*Fig. 6*



*Fig. 7*



*Fig. 8*

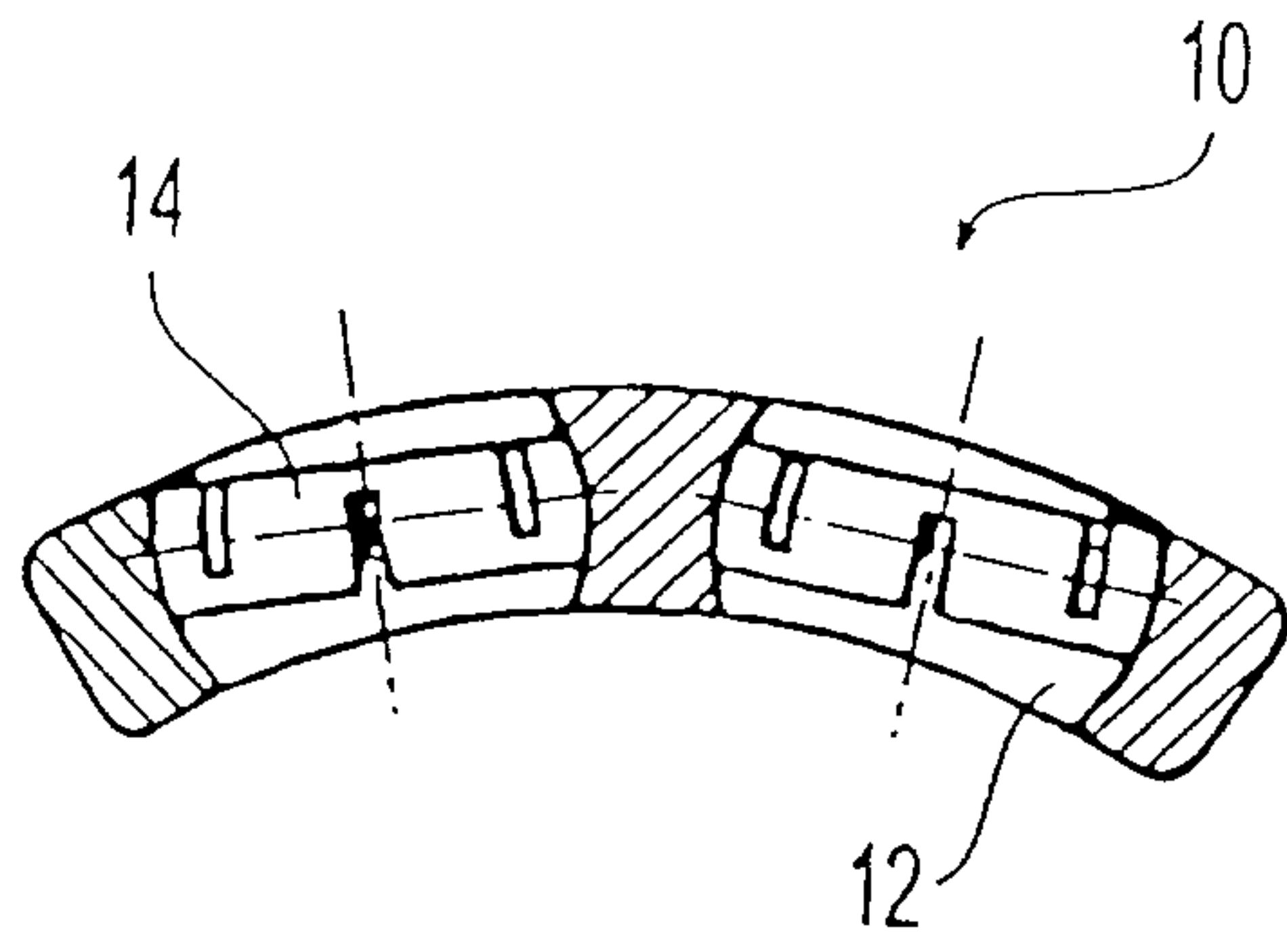

*Fig. 9*

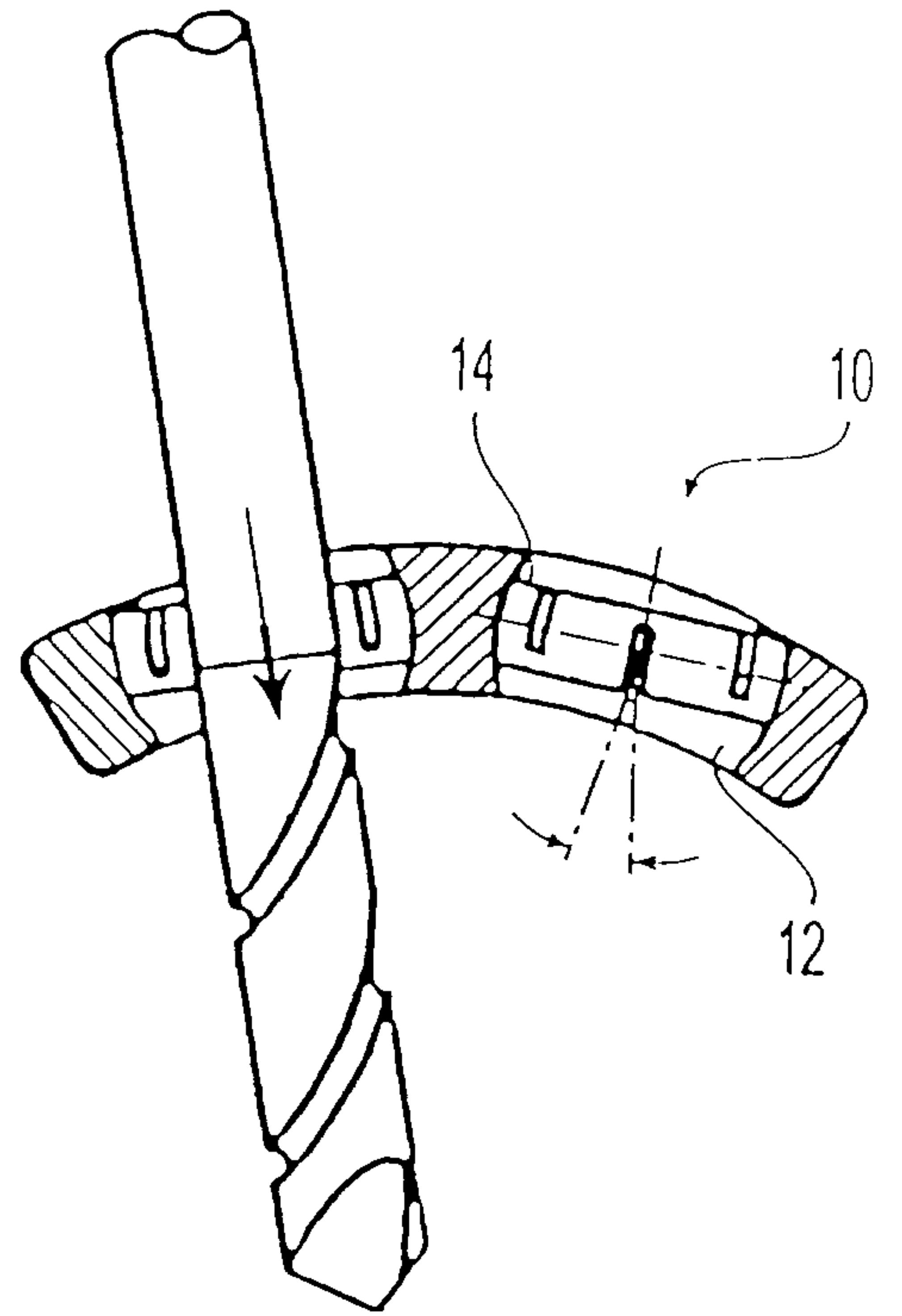

*Fig. 10*

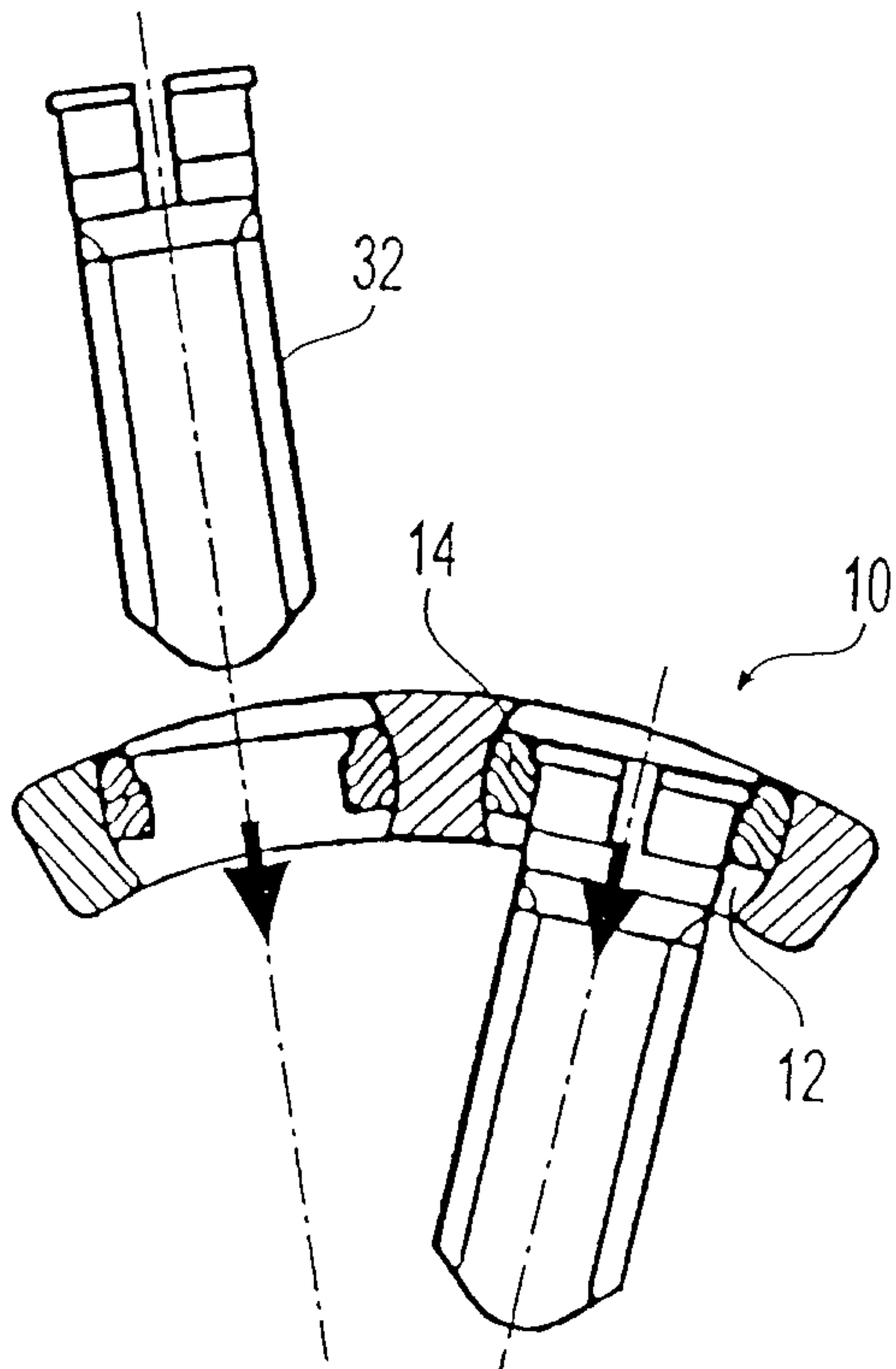

*Fig. 11*

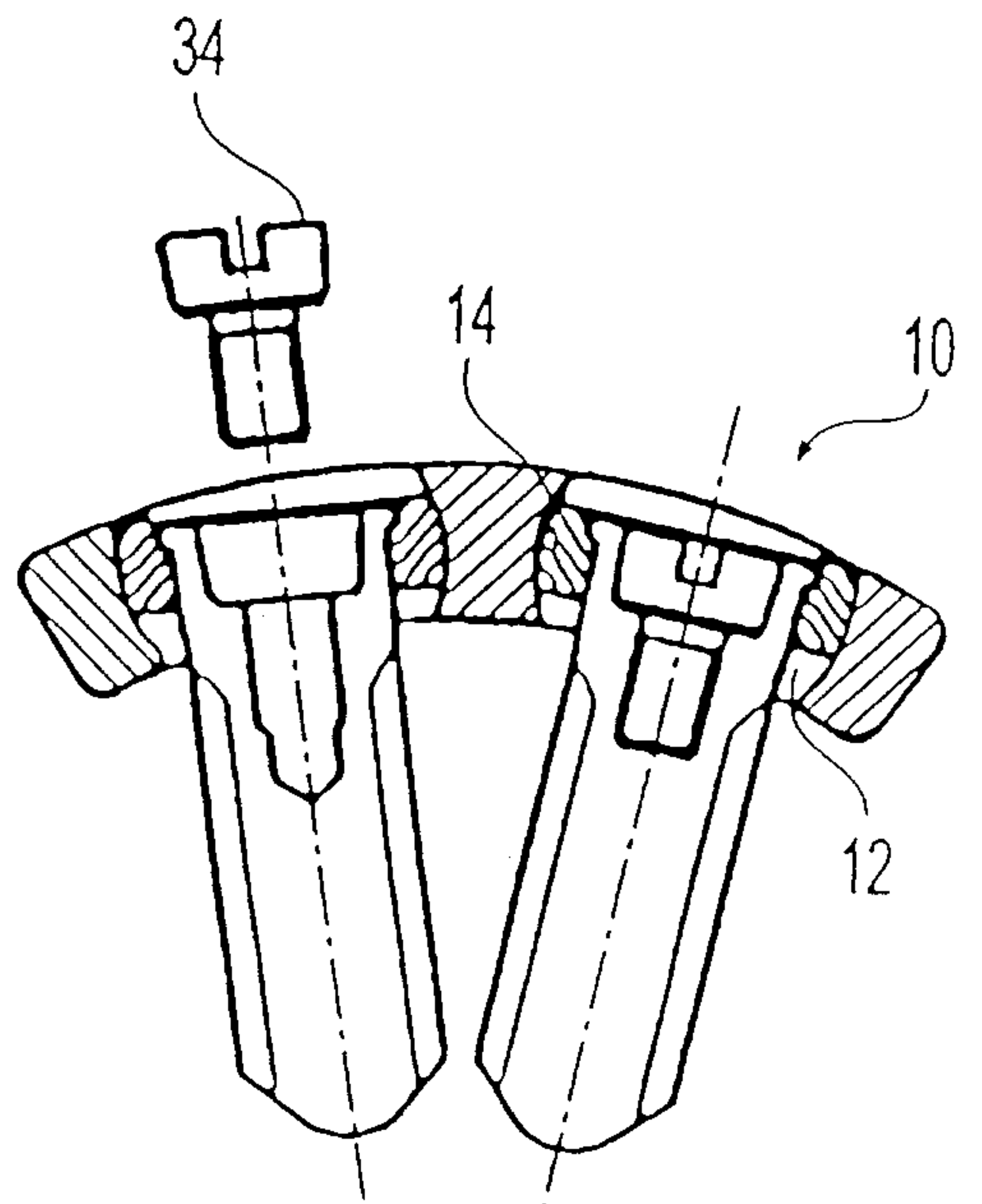

*Fig. 12*

