



- (51) International Patent Classification:  
G01S 7/495 (2022.01) H01S 3/23 (2022.01)
- (21) International Application Number:  
PCT/IL2021/051262
- (22) International Filing Date:  
25 October 2021 (25.10.2021)
- (25) Filing Language: English
- (26) Publication Language: English
- (30) Priority Data:  
278274 25 October 2020 (25.10.2020) IL  
282027 24 March 2021 (24.03.2021) IL
- (72) Inventor; and  
(71) Applicant: COHEN, David [IL/IL]; 2 HaEtrog Street, Apt. 4, 4630902 Herzliya (IL).
- (74) Agent: EHRLICH, Gal et al.; G. E. EHRLICH (1995) LTD., 11 Menachem Begin Road, 5268104 Ramat-Gan (IL).
- (81) Designated States (unless otherwise indicated, for every kind of national protection available): AE, AG, AL, AM, AO, AT, AU, AZ, BA, BB, BG, BH, BN, BR, BW, BY, BZ, CA, CH, CL, CN, CO, CR, CU, CZ, DE, DJ, DK, DM, DO, DZ, EC, EE, EG, ES, FI, GB, GD, GE, GH, GM, GT, HN,

HR, HU, ID, IL, IN, IR, IS, IT, JO, JP, KE, KG, KH, KN, KP, KR, KW, KZ, LA, LC, LK, LR, LS, LU, LY, MA, MD, ME, MG, MK, MN, MW, MX, MY, MZ, NA, NG, NI, NO, NZ, OM, PA, PE, PG, PH, PL, PT, QA, RO, RS, RU, RW, SA, SC, SD, SE, SG, SK, SL, ST, SV, SY, TH, TJ, TM, TN, TR, TT, TZ, UA, UG, US, UZ, VC, VN, WS, ZA, ZM, ZW.

- (84) Designated States (unless otherwise indicated, for every kind of regional protection available): ARIPO (BW, GH, GM, KE, LR, LS, MW, MZ, NA, RW, SD, SL, ST, SZ, TZ, UG, ZM, ZW), Eurasian (AM, AZ, BY, KG, KZ, RU, TJ, TM), European (AL, AT, BE, BG, CH, CY, CZ, DE, DK, EE, ES, FI, FR, GB, GR, HR, HU, IE, IS, IT, LT, LU, LV, MC, MK, MT, NL, NO, PL, PT, RO, RS, SE, SI, SK, SM, TR), OAPI (BF, BJ, CF, CG, CI, CM, GA, GN, GQ, GW, KM, ML, MR, NE, SN, TD, TG).

**Declarations under Rule 4.17:**

- of inventorship (Rule 4.17(iv))

**Published:**

- with international search report (Art. 21(3))
- before the expiration of the time limit for amending the claims and to be republished in the event of receipt of amendments (Rule 48.2(h))

(54) Title: ATMOSPHERE-PENETRATING LASER

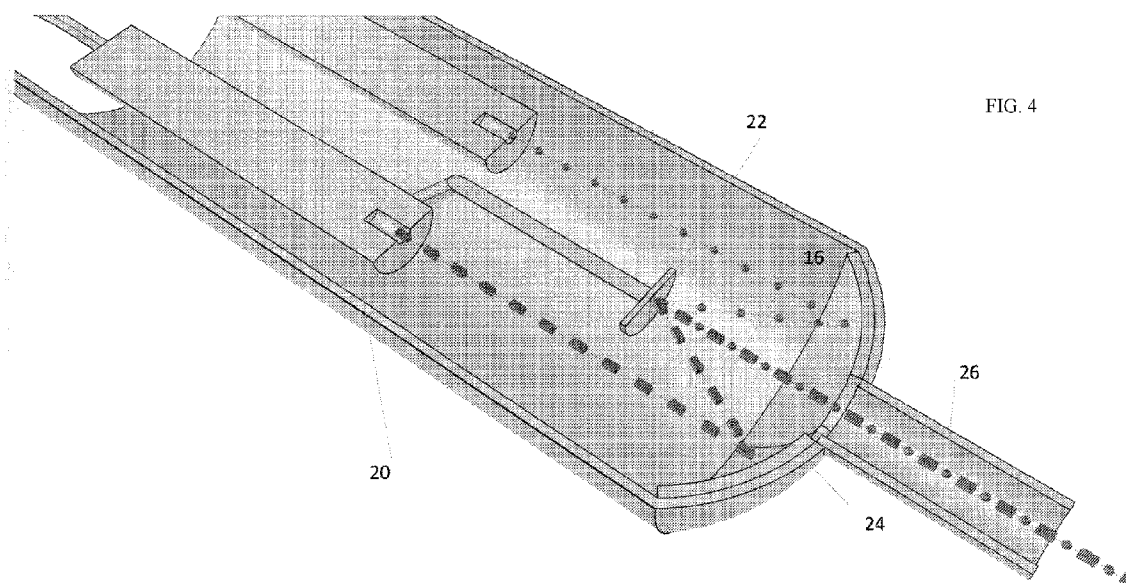

FIG. 4

(57) Abstract: A laser beam for improved atmospheric penetration is produced by a device having two or more laser sources each producing a laser beam of a different wavelength. The beams are combined by an optical combiner into a composite beam having at least two wavelengths, so that the different properties of the different wavelengths may combine to improve atmospheric penetration.



## ATMOSPHERE-PENETRATING LASER

RELATED APPLICATION/S

This application claims the benefit of priority of Israel Patent Application No. 278274 filed  
5 on 25 October 2020 and of Israel Patent Application No. 282027 filed on 24 March 2021, the  
contents of which are incorporated herein by reference in their entirety.

FIELD AND BACKGROUND OF THE INVENTION

The present invention relates to a device and method for improving atmospheric  
10 penetration by laser.

Lasers, first invented in the 1960's, are now widely used in numerous applications. Some  
of those applications require the laser beam to penetrate distances through the atmosphere. Such  
applications include but are not limited to LIDAR, laser range finding, laser guidance systems for  
weapons and missile defense systems.

15 However laser energy tends to get absorbed by the atmosphere creating a "thermal  
blooming" phenomena, so whereas a very small low power laser beam may travel tens of  
kilometers in a light guide and carry signals, in the atmosphere the beam energy is attenuated due  
to a plurality of factors such as air composition at deferent altitude, moisture content, temperature,  
dust, etc., thus long distance applications need relatively high power laser beams to have any effect  
20 at a distance. LIDAR and Laser range finding and guidance systems require some but not much  
energy to reach the target but a laser beam intended for destroying incoming missiles does depend  
on the amount of energy reaching the target. In particular, atmospheric conditions define the extent  
to which the laser beam is attenuated, so that on some days a given output power may be sufficient  
and on other days it may not.

25 A way of making atmospheric penetration by a laser beam more effective and more  
predictable would thus be welcome.

SUMMARY OF THE INVENTION

The present inventors noted that different wavelengths of laser react in different ways to a  
30 plurality of atmospheric factors. Thus long but lower energy red wavelengths tend to be simply  
blocked whereas short higher energy wavelengths tend to heat the moisture etc and thus dissipate  
their energy.

Thus the idea is to provide two or more laser beams of different wavelength and combine  
them into a single beam, typically using optics. The resulting composite beam may then combine

the behaviors of both wavelengths and provide improved penetration through the atmosphere. Thus as a non-limiting example, the higher energy beam may heat the atmosphere along the length of the beam causing moisture and dust to dissipate and create a tunnel for the lower energy beam.

According to an aspect of some embodiments of the present invention there is provided a device comprising:

- 5 a first laser source configured to produce a laser beam of a first wavelength;
- at least a second laser source configured to produce a laser beam of a second wavelength; and
- an optical combiner configured to combine the first and at least the second laser beams into a single composite beam having at least two wavelengths.

In embodiments, the first wavelength is from the red end of the spectrum and the second wavelength is from the blue end of the spectrum.

In embodiments, the first wavelength and the second wavelength are selected for their different behaviors during atmospheric penetration.

15 Embodiments may have three, four, five, six or more laser sources, each with different wavelengths, or some may have the same wavelengths but may be pulsed differently.

In embodiments, one of the wavelengths is selected as a transport wavelength, to clear a path through the atmosphere and ensure that a second of the wavelengths arrives at a target with a minimum of attenuation.

20 In embodiments, the combined beam comprises the transport wavelength alongside or surrounding the second of the wavelengths, thereby to clear a path in the vicinity of the second of the wavelengths.

According to a second aspect of the present invention, there is provided a laser beam in the atmosphere, the laser beam comprising at least two wavelengths, each wavelength selected for a different behavior during atmospheric penetration.

The beam may have three or more different wavelengths or pulse patterns.

In embodiments of the device or of the laser beam, one of the wavelengths is selected to heat water vapor encountered more than other wavelengths, thereby to clear a path for the other wavelengths by heating the vapor and causing currents of air to remove dust and water vapor from the path.

30 Unless otherwise defined, all technical and/or scientific terms used herein have the same meaning as commonly understood by one of ordinary skill in the art to which the invention pertains. Although methods and materials similar or equivalent to those described herein can be used in the practice or testing of embodiments of the invention, exemplary methods and/or

materials are described below. In case of conflict, the patent specification, including definitions, will control. In addition, the materials, methods, and examples are illustrative only and are not intended to be necessarily limiting.

5 BRIEF DESCRIPTION OF THE SEVERAL VIEWS OF THE DRAWING(S)

Some embodiments of the invention are herein described, by way of example only, with reference to the accompanying drawings. With specific reference now to the drawings in detail, it is stressed that the particulars shown are by way of example and for purposes of illustrative discussion of embodiments of the invention. In this regard, the description taken with the drawings  
10 makes apparent to those skilled in the art how embodiments of the invention may be practiced. In the drawings:

FIG. 1 is simplified diagram showing a device for producing a laser beam for improved atmospheric penetration according to a first embodiment of the present invention;

FIGs. 2A-B are a cross-section of a variation of the device of Fig. 1;

15 FIG. 3 is an exploded diagram showing the parts of the device of Figs. 2A-B;

FIG. 4 is a cross-sectional view of the device of Fig. 1 showing beam paths;

FIG. 5 is a view of a second embodiment of the present invention;

FIG. 6 is a view of the device of Fig. 5 with the cover of the combiner removed;

FIG. 7 is a view of the device of Fig. 5 with the laser beams shown;

20 FIG. 8 is a simplified diagram showing communication between two locations along a line of sight using an embodiment of the present invention;

FIG. 9 is a simplified diagram showing a satellite for use with the present embodiments;

FIG. 10 is a simplified diagram showing a chain of satellites providing communication between two points on the earth's surface;

25 FIG. 11 shows how satellites may be used with the present embodiments to allow for control of a missile over the horizon;

FIG. 12 shows a drone for use with the present embodiments;

FIG. 13 shows a laser beam according to the prior art and indicating dispersal of energy of the laser beam; and

30 FIG. 14 is a simplified diagram showing a concentrated beam protected by an atmospheric tunnel according to embodiments of the present invention.

DESCRIPTION OF SPECIFIC EMBODIMENTS OF THE INVENTION

The present invention relates to a device for improving the atmospheric penetration of laser beams.

In the present embodiments, two or more lasers of different wavelengths and an optical combiner are provided. A single composite beam is produced which then combines the abilities of  
5 all the wavelengths included in order to improve atmospheric penetration.

Before explaining at least one embodiment of the invention in detail, it is to be understood that the invention is not necessarily limited in its application to the details of construction and the arrangement of the components and/or methods set forth in the following description and/or  
10 illustrated in the drawings and/or the Examples. The invention is capable of other embodiments or of being practiced or carried out in various ways.

Referring now to the drawings, Figure 1 illustrates a device 10 having two laser sources 12 and 14, each connected to an optical combiner 16, which combines the lasers into a single composite beam.

The first laser source 12 produces a laser beam of a first wavelength. The second laser source 14 produces a laser beam having a second wavelength different from the first wavelength. Further laser sources may be added to increase the number of wavelengths used.  
15

The optical combiner 16 may combine the first, second and any other laser beams into a single composite beam having both wavelengths. The beam may include the different wavelengths directly following a single path or the beam may be shaped so that one wavelength surrounds the other or is next to the other, as will be explained below.  
20

The laser sources are optically connected to the optical combiner 16, for example using optical fibers 18.

Reference is now made to Figs. 2A-B, which is a cross section of the device of Fig. 1. Parts that are the same are given the same reference numerals and are not described again except as required for an understanding of the present view. The laser sources 12 and 14 provide their laser energy to the optical fibers 18 which end at terminations 20 in the combiner 16. The combiner 16 comprises an arrangement of mirrors and/or lenses that receives and combines the two wavelengths into a single beam. Specifically, mirrors 22 and 24 serve to combine the beams into  
30 a single beam and reflect them out through outlet 26. It is noted that the mirror 24 has a suitable shape such as a parabolic surface (not shown) to deflect the beams from either side towards the outlet.

Reference is now made to Figs. 2B which is a cross-section as with Fig 2A but of a variation of the device of Fig. 1 in which a lens 25 is added between the mirror 24 and mirror 22. The lens

may change the focus of the beam to carry out beam shaping or widen or narrow the beam path. The lens may be centrally located as shown or may be to the side to intercept just one of the beams prior to combination.

Reference is now made to Fig. 3, which is an exploded diagram showing the parts of Figs. 2A-B. As shown the mirror 24 has a central opening 28 to allow the combined beam to pass outwardly to outlet 26. As shown in greater detail in Fig. 4 the first laser source produces beam 30 and the second laser source produces beam 32. The mirror 24 receives the beams 30 and 32 at either side from each of the laser sources and reflects them back to mirror 22. Mirror 22 receives the beams at an angle from mirror 24 and directs them together towards the opening 28 in mirror 24 and through to outlet 26.

Reference is now made to Figs. 5, which is a simplified diagram showing a variation of the embodiment of Fig. 1 in which multiple laser sources are used to provide the composite beam. Three, four, five, six or more wavelengths may be used, and the present figure illustrates a six wavelengths. More particularly, laser sources 40, 42, 44, 46, 48 and 50 are connected to combiner 52 which has outlet 54 for outputting the composite laser beam. The laser sources are connected to the combiner via optical fibers 56.

Reference is now made to Fig. 6, which is a cutaway drawing of the device of Fig. 5 with the casing of the combiner removed. As in Fig. 5, laser sources 40, 42, 44, 46, 48 and 50 are connected to the combiner, where terminations 57 terminate the optical fibers 56. The beams go to mirror 58 where they are reflected back to mirror 60 and combined to exit at opening 62. Fig. 7 is the same view but showing the multiple beams 70 from the different laser sources being combined by the mirrors into single output beam 72.

In use, the different beams are of different wavelengths. For example one of the wavelengths may be from the red part of the spectrum and a second wavelength may be from the blue end of the spectrum. Typically, the wavelengths are selected for their different behaviors during atmospheric penetration. Thus one wavelength may tend to heat water vapor encountered more than other wavelengths and may be taken advantage of to clear a path for the other wavelengths by heating the vapor and causing currents of air to remove dust and water vapor out of the way. Hence, a particular wavelength may be provided because of its properties as a transport wavelength, to clear a path through the atmosphere and ensure that another wavelength arrives at a target with a minimum of attenuation.

The transport wavelength may actually overlap and coincide with the second of the wavelengths, or it may be alongside or surrounding the second wavelength. In either case a path

may be cleared by the beam to allow the intended energy to get through without attenuation or with minimal attenuation.

The wavelengths may be pulsed, and the different wavelengths may be pulsed differently, so that each one may be optimized separately for its respective intended effect. It is further noted that more than one of the multiple laser sources may be used with the same wavelength but pulsed differently to provide different effects. The different pulses may be used to identify the different beams for example in cases where reflections of the beams are used to identify distances or atmospheric disturbances. Reflections due to atmospheric disturbances may be used to refine the atmospheric penetration of the device. For example a particular pattern of reflections may indicate a particular characteristic of the atmosphere and then the device may modify the beam by altering the pulses or wavelengths used accordingly. Such methods of characterizing the atmosphere using laser are known in the art.

The method may also be used with optical equipment to create a path through which the optical device can see without thermal distortion. Such a path may be used with an optical device intended to see into the distance, including astronomical viewing.

In an airplane travelling through fog, an embodiment may be used to clear a path of visibility for the pilots.

Reflections of the laser beam may be used to indicate changes in atmospheric conditions and make corresponding changes to the channel. In other embodiments a detector at the far end may detect changes and control the necessary changes. Such changes may involve changes in signal strength or in some cases to changes in the wavelengths used. Meteorological data may be used as an input to the laser system to optimize the system for current atmospheric conditions, and such data may be obtained for example by use of radar. Such optimization may stabilize the system even in adverse atmospheric conditions.

Reference is now made to Fig. 8, which is a simplified diagram showing a laser source according to the present embodiments carrying out communication with a detector 82. If the detector 82 is also a laser source and the source 80 also includes a detector, then two-way communication is also possible. The use of multiple wavelengths as before creates a communication tunnel where the amount of distortion or diffusion or attenuation is minimized. As a result, a straight line laser communication path may be set up and less power used than in conventional laser communication. However line of sight is required by the laser.

Reference is now made to Fig. 9, in which satellite 90, in earth orbit, has a body 92, a reflector 94 and solar panels 96. The satellite reflector 94 may be used to redirect the laser beam from one location to another and overcome the earth's curvature. In addition, the laser beam may

be absorbed to provide power to the satellite, say in the case of failure of the solar panels. The base 98 of the reflector 94 may include a universal joint and an actuator so that the reflector angle can be accurately changed in three dimensions. It will be appreciated that a single satellite may have multiple reflectors. The multiple reflectors may deal with multiple sources and/or may deal with multiple destinations or targets. Thus a single source may control multiple missiles or multiple sources may communicate with each other or control missiles.

As shown in Fig. 10, communication from a first location 100 reaches a second location 102 despite the earth's curvature. The beam is the multiple wavelength beam of the previous embodiments, which creates a tunnel that is free from distortion, attenuation etc, and thus means that a laser beam may carry communication over long distances. The beam is carried between satellites 104, 106 and 108, and the satellites include reflectors as shown in Fig. 9. As above, the communication may be bidirectional.

Reference is now made to Fig. 11, which shows how the laser beam may be used to control a ballistic missile over the horizon. Control station 110 controls missile 112 over the horizon. A control laser beam is sent via satellites 114 and 116, and the missile may also transmit data such as its GPS position or altitude, or speed or attitude or a view of the target etc in the reverse direction. The control beam may in fact be multiple beams from multiple sources.

Reference is now made to Fig. 12, which is a simplified diagram that shows a drone 120. The drone receives a laser beam according to the present embodiments, and in one embodiment is controlled by signaling from the beam, which gives full line of sight control. The drone is also able to relay the beam, for example to direct it to another drone that is over the horizon from the beam source, so that the drone serves in the same way as the satellite referred to above. The drone is also able to relay the beam between two ground locations to provide communication between locations that do not have line of sight. It is noted that communication is hard to intercept or interfere with since the beam is very narrow and is constantly changing its route as the drone moves.

The beam may also be used to power the drone or assist with powering the drone, so that the drone may remain airborne for longer.

Reference is now made to Fig. 13 which shows a missile 130 being controlled by a prior art laser beam 132. Despite the beam being a laser beam, atmospheric dispersion of the beam so that over distance there is no concentrated energy. Adaptive optics may be used to stabilize the system and achieve optimal results.

Reference is now made to Fig. 14 which shows a missile 140 being controlled by a beam according to the present embodiments. A tunnel 142 is set up and within the tunnel, beam 144 reaches the missile without distortion.

The devices of the present embodiments may be used to provide laser beams for any application where significant atmospheric penetration is required and in particular for those applications where minimizing power attenuation is critical.

5 In an embodiment, both the beams may be of the same wavelength, thus avoiding interference between the two beams. Operation may be the same in that an outer shape of beam engulfs the passage of the inner beam and thus clears a path as above. The embodiment may thus prevent or reduce terminal bluming.

10 In an embodiment, two combined beams may be provided side by side, so that one of the beam combinations may protect or help to protect the other beam combination from effects of directional atmospheric disturbance, such as winds. The protection may be provided by a single beam rather than a combination beam, and in an embodiment, both of the beams may be simple beams.

15 The device may be combined with a weather sensing system or wind sensing system so as to position the two beams to provide protection, or more generally to calibrate in respect of the weather, for the purposes of optimization etc. A third beam may be provided for calibration purposes.

20 It is noted that the laser beam has a defined range of efficiency through the atmosphere. The combination has an increased range of efficiency. However the combination may additionally be used to provide a stage for a further length. That is to say one combined beam may provide a tunnel that provides an initial base for a second, third and more tunnels, thus telescoping the effective range. It is possible to calculate in advance, or observe, the optimum effective beam range for a given section of atmosphere. Using telescoping it is possible to provide different optimizations for different sections of an atmospheric path. Observations may be optical or using electromagnetic means. Spectral observations may be used.

25 Using the above techniques, the beams being used by the system may be changed during the course of an interception operation.

30 It is possible for the system to hit something and detect its range at an initial low power. If the range is not consistent with the expected threat, or the range is consistent with friendly forces, the system remains at low power and does no harm. Only if the range is consistent with an expected threat is the power turned up to cause damage.

The terms "comprises", "comprising", "includes", "including", "having" and their conjugates mean "including but not limited to".

The term "consisting of" means "including and limited to".

As used herein, the singular form "a", "an" and "the" include plural references unless the context clearly dictates otherwise.

It is appreciated that certain features of the invention, which are, for clarity, described in the context of separate embodiments, may also be provided in combination in a single  
5 embodiment, and the text is to be construed as if such a single embodiment is explicitly written out in detail. Conversely, various features of the invention, which are, for brevity, described in the context of a single embodiment, may also be provided separately or in any suitable subcombination or as suitable in any other described embodiment of the invention, and the text is to be construed as if such separate embodiments or subcombinations are explicitly set forth herein in detail.

10 Although the invention has been described in conjunction with specific embodiments thereof, it is evident that many alternatives, modifications and variations will be apparent to those skilled in the art. Accordingly, it is intended to embrace all such alternatives, modifications and variations that fall within the spirit and broad scope of the appended claims.

All publications, patents and patent applications mentioned in this specification are herein  
15 incorporated in their entirety by reference into the specification, to the same extent as if each individual publication, patent or patent application was specifically and individually indicated to be incorporated herein by reference. In addition, citation or identification of any reference in this application shall not be construed as an admission that such reference is available as prior art to the present invention. To the extent that section headings are used, they should not be construed  
20 as necessarily limiting.

In addition, any priority document(s) of this application is/are hereby incorporated herein by reference in its/their entirety.

## WHAT IS CLAIMED IS:

1. A device comprising:
  - A first laser source configured to produce a laser beam of a first wavelength;
  - At least a second laser source configured to produce a laser beam of a second wavelength;
  - An optical combiner configured to combine the first and at least the second laser beams into a single composite beam having at least two wavelengths.
2. The device of claim 1, wherein the first wavelength is a red wavelength and the second wavelength is a blue wavelength.
3. The device of claim 1 or claim 2, wherein the first wavelength and the second wavelength are selected for their different behaviours during atmospheric penetration.
4. The device of any one of the preceding claims, comprising at least three laser sources.
5. The device of any one of the preceding claims, comprising at least four laser sources.
6. The device of any one of the preceding claims, wherein one of the wavelengths is selected as a transport wavelength, to clear a path through the atmosphere and ensure that a second of the wavelengths arrives at a target with a minimum of attenuation.
7. The device of any one of the preceding claims, wherein the combined beam comprises the transport wavelength alongside or surrounding the second of the wavelengths, thereby to clear a path in the vicinity of the second of the wavelengths.
8. The device of any one of claims 1 to 7, configured to provide an outer shape using said first beam and to provide said second beam inside said outer shape.
9. A laser beam in the atmosphere, the laser beam comprising at least two wavelengths, each wavelength selected for a different behavior during atmospheric penetration.
10. The laser beam of claim 9, comprising at least three different wavelengths.

11. The laser beam of any one of claims 9 to 10, wherein one of the wavelengths is selected as a transport wavelength, to clear a path through the atmosphere and ensure that a second of the wavelengths arrives at a target with a minimum of attenuation.
12. The laser beam of claim 11, wherein the transport wavelength is directed alongside or surrounding the second of the wavelengths, thereby to clear a path in the vicinity of the second of the wavelengths.
13. The laser beam of any one of claims 9 to 12, wherein one of the wavelengths is selected for an ability to heat water vapor encountered to a greater extent than other wavelengths, thereby to clear a path for the other wavelengths by heating the vapor and causing currents of air to remove dust and water vapor from the path.
14. A method of communication with laser comprising using the device of any one of claims 1 - 7.
15. A method of communication with laser comprising using the laser beam of any one of claims 9 to 13.
16. The method of communication of claim 15, comprising relaying the beam via one or more satellites.
17. The method of communication of claim 15 comprising relaying the beam via one or more drones.
18. A method of powering a satellite or drone comprising providing to the satellite or drone the laser beam of any one of claims 9 to 13, and absorbing power from the beam.
19. A method of powering a satellite or drone comprising providing to the satellite or drone a laser beam from the device of any one of claims 1 to 8 and absorbing power from the beam.
20. A device comprising  
at least one laser source configured to produce a laser beam of a first wavelength, the wavelength selected to exert a first effect on the atmosphere;

at least a second laser source configured to produce a laser beam of a second wavelength selected to exert a second effect on the atmosphere; and

an optical combiner configured to combine the first and at least the second laser beams into a single composite beam having at least two wavelengths to produce a composite effect on the atmosphere.

21. The device of claim 20, further comprising an optical sensor, the optical sensor being aligned along the composite beam.

22. The device of claim 21, wherein the optical sensor is an astronomical sensor.

23. The device of any one of claims 20 to 22, further configured to use reflections from said wavelengths to optimize said combined beam in the face of atmospheric changes.

24. The device of claim 23, further configured to use radar or meteorological data to optimize said combined beam.

25. A device comprising:

a first laser source configured to produce a laser beam of a first wavelength;

at least a second laser source configured to produce a laser beam also of said first wavelength;

an optical combiner configured to combine the first and at least the second laser beams into a single composite beam.

26. The device of claim 25, wherein the first and second laser sources are configured to operate at the same time.

27. The device of claim 25, wherein the first and second laser sources are configured to operate one after the other.

28. The device of any one of claims 25 to 27, configured to produce a ring of laser beams.

29. The device of any one of claims 1 to 8 or 25 to 28, wherein said combined beam is combined with at least one further combined beam to provide telescoped laser beam stages, thereby to increase an effective range.

30. The device of any one of claims 1 to 8 or 24 to 29, configured to provide a second combined beam alongside said combined beam, thereby to provide shielding from atmospheric disturbance.

31. The device of any one of claims 1 to 8 or 25 to 30, combined with a weather sensing unit or a wind sensing unit.

32. The device of claim 31, comprising a second combined beam to provide said weather sensing.

FIG. 1

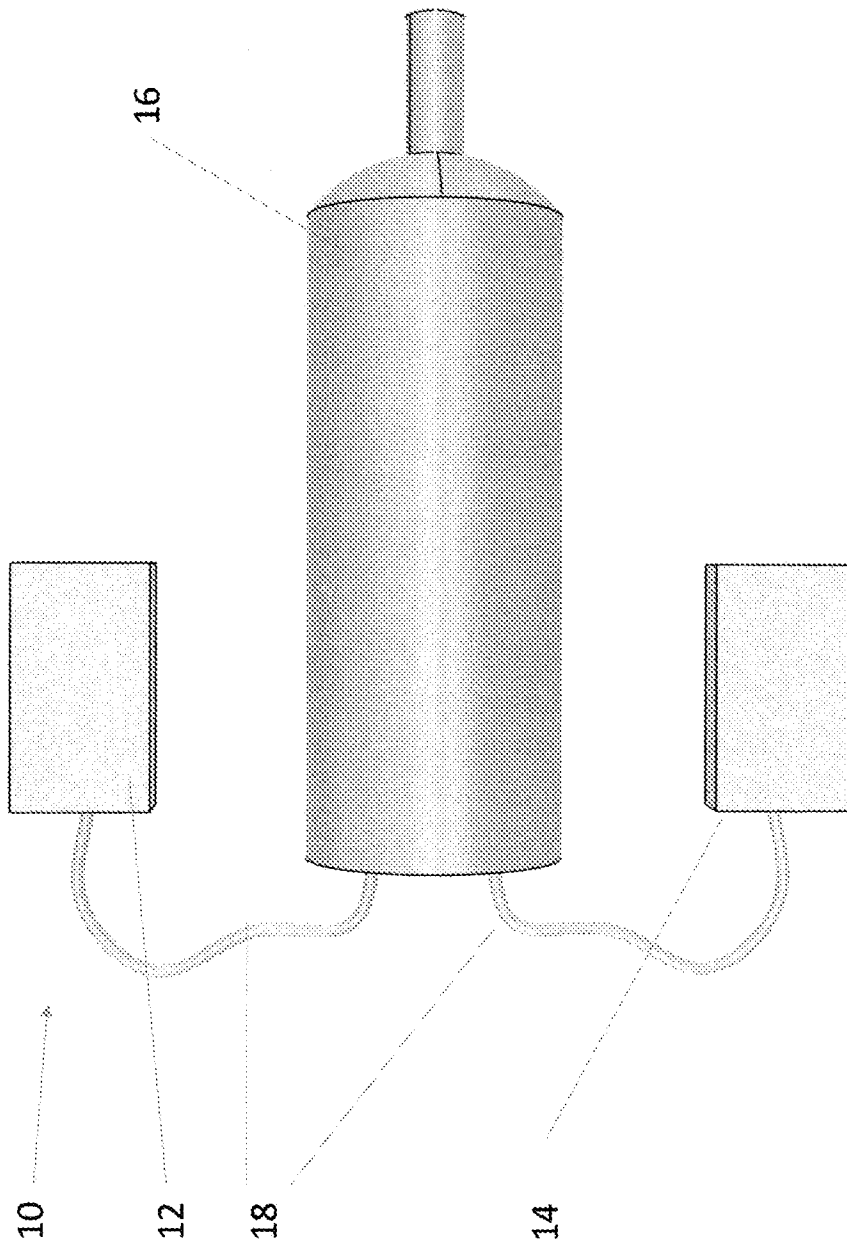

FIG. 2A

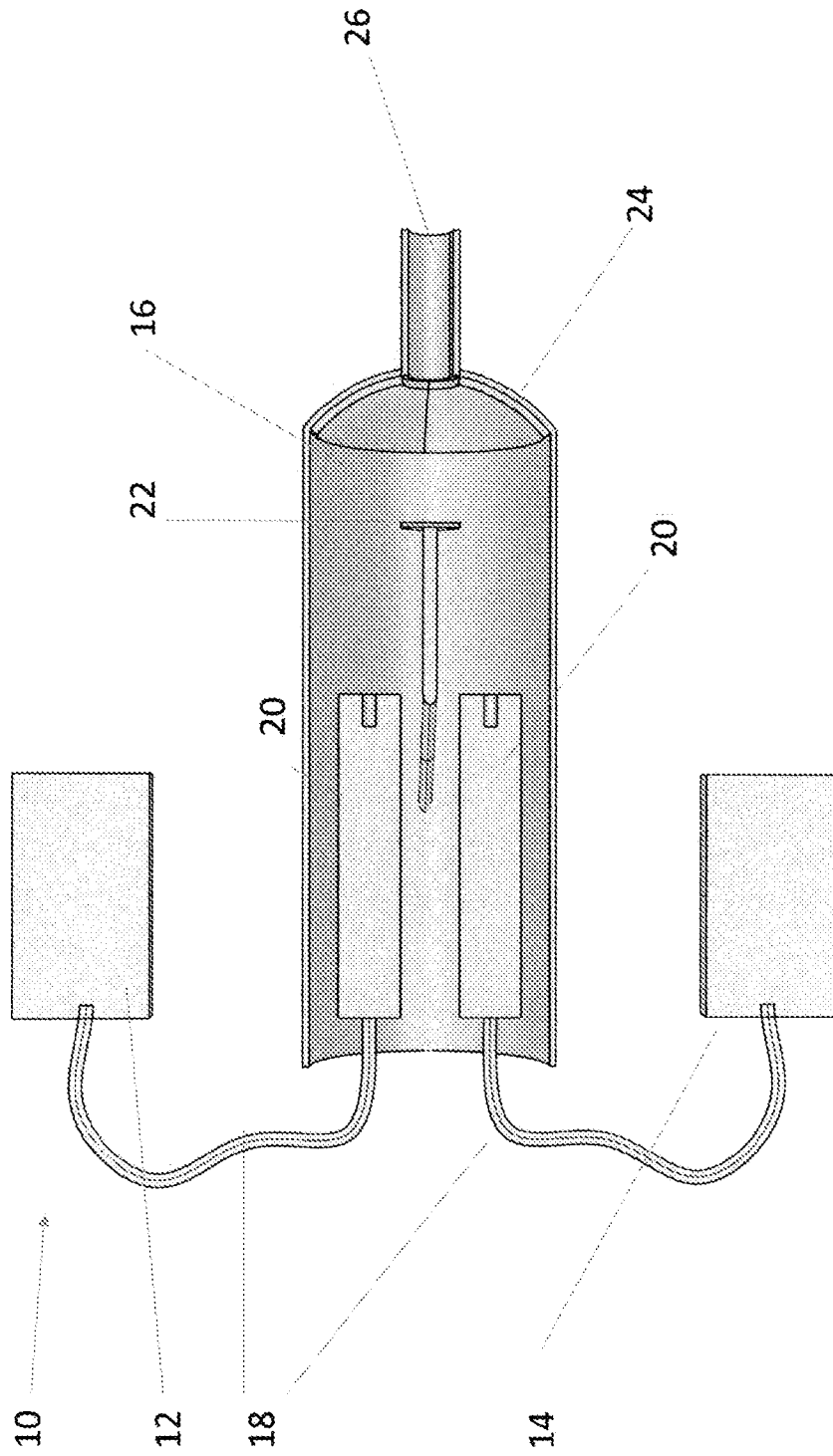



FIG. 3

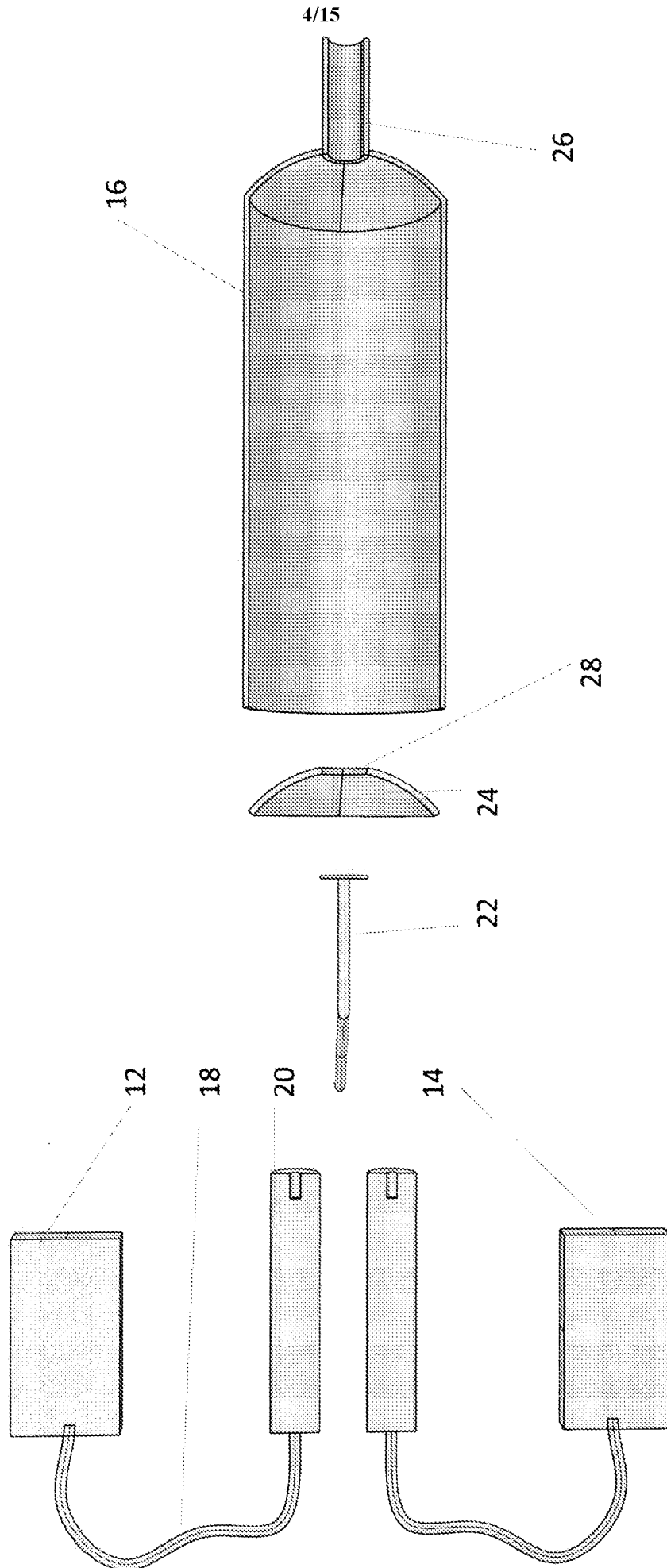



FIG. 5

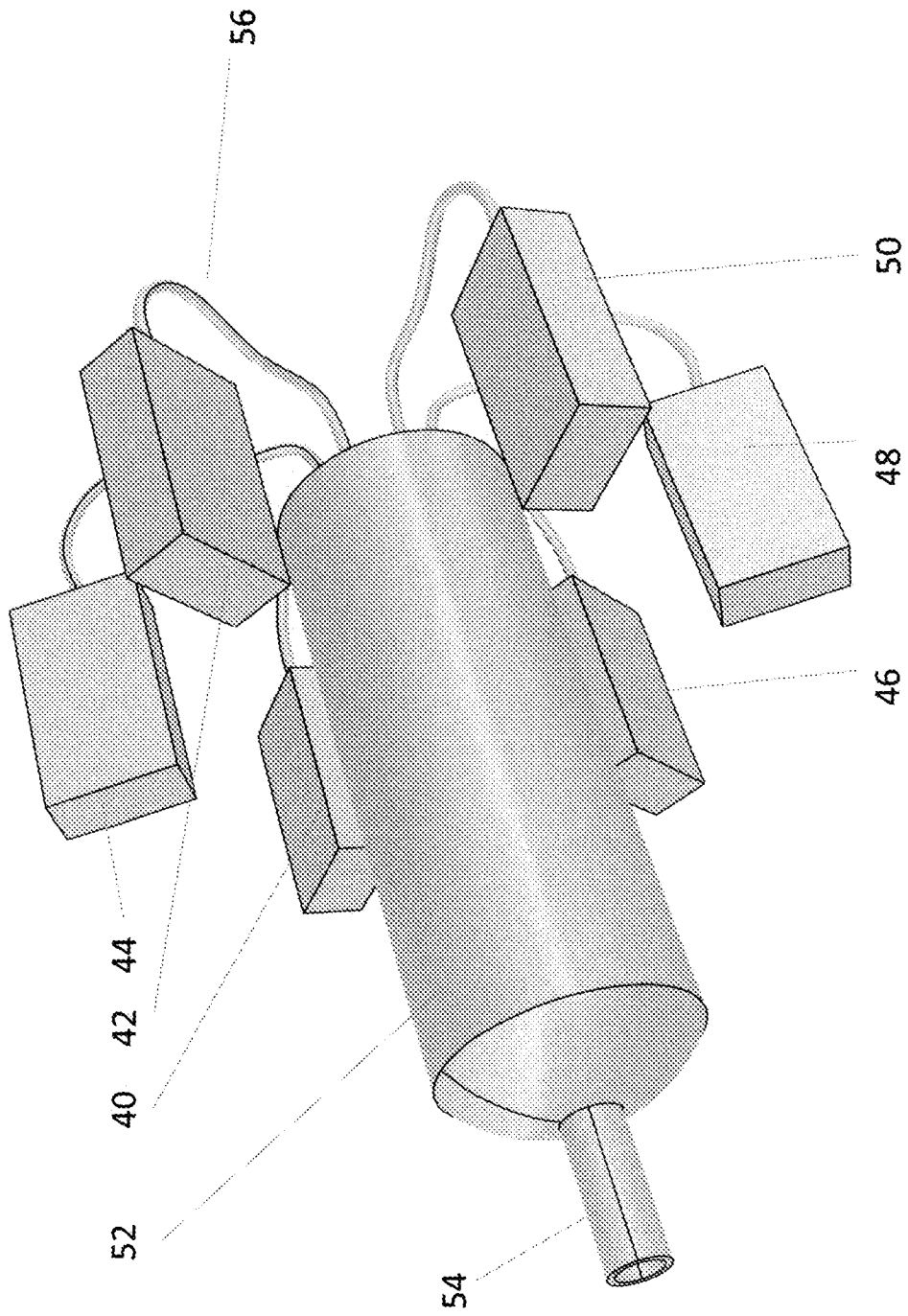

FIG. 6

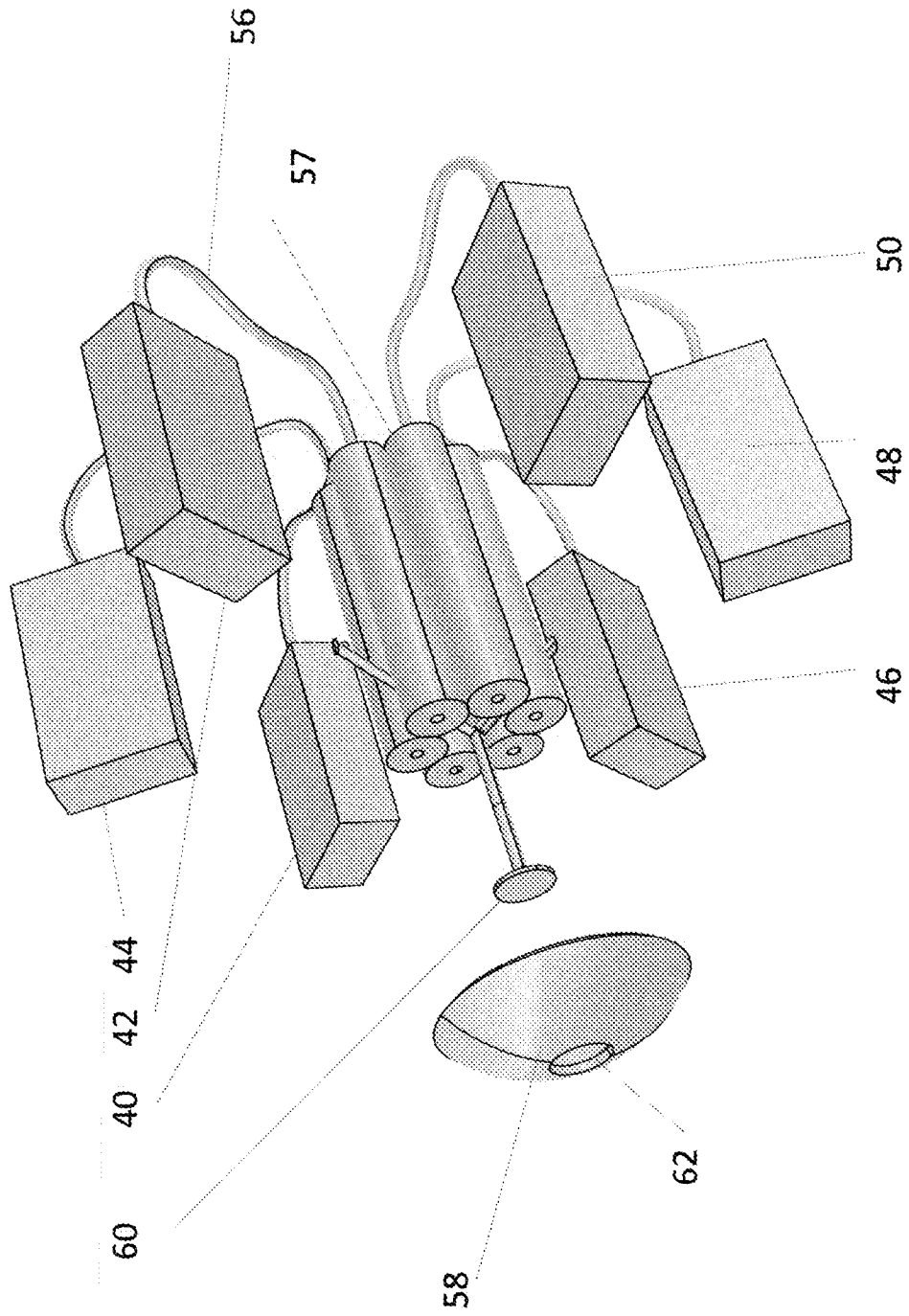

FIG. 7

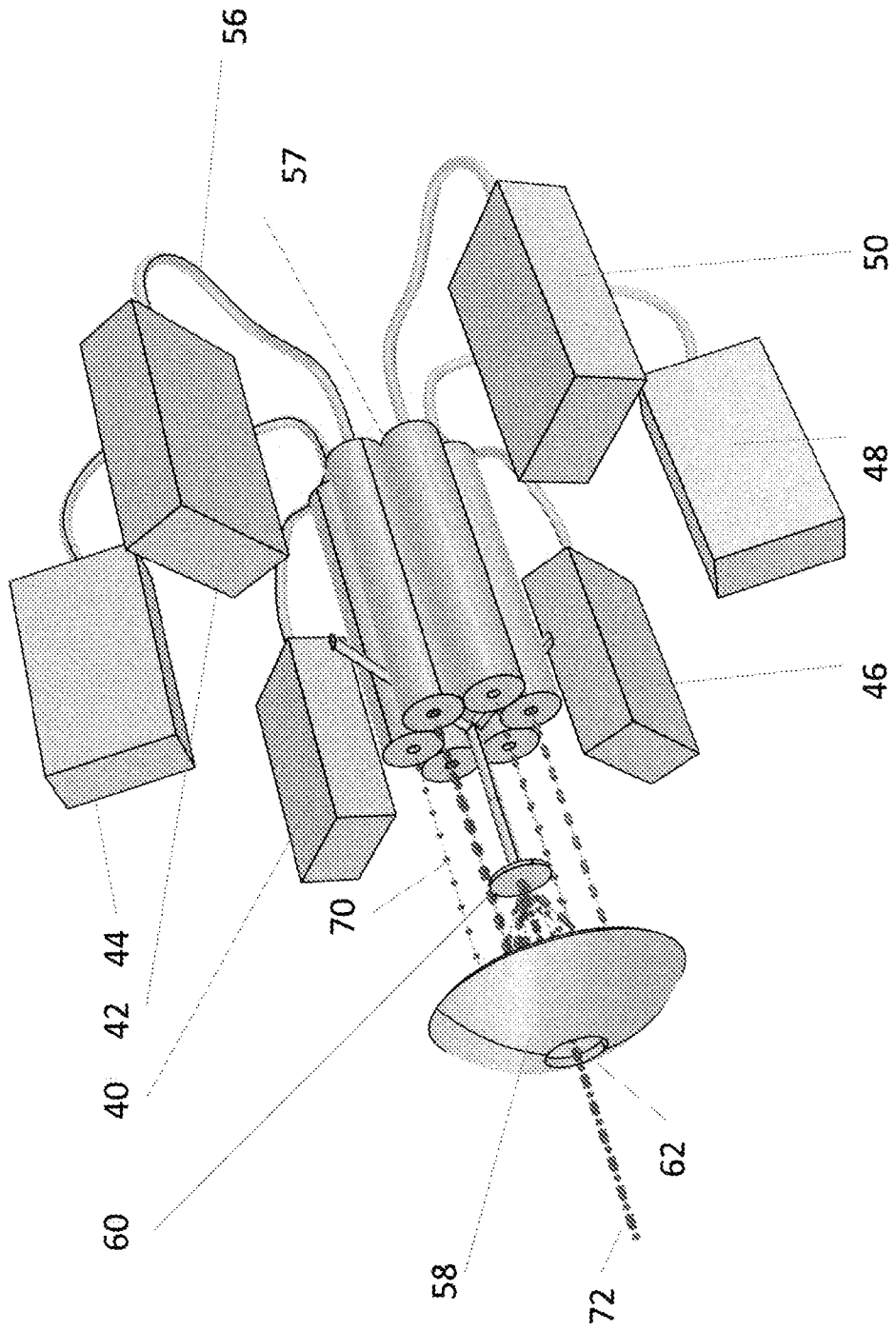

FIG. 8

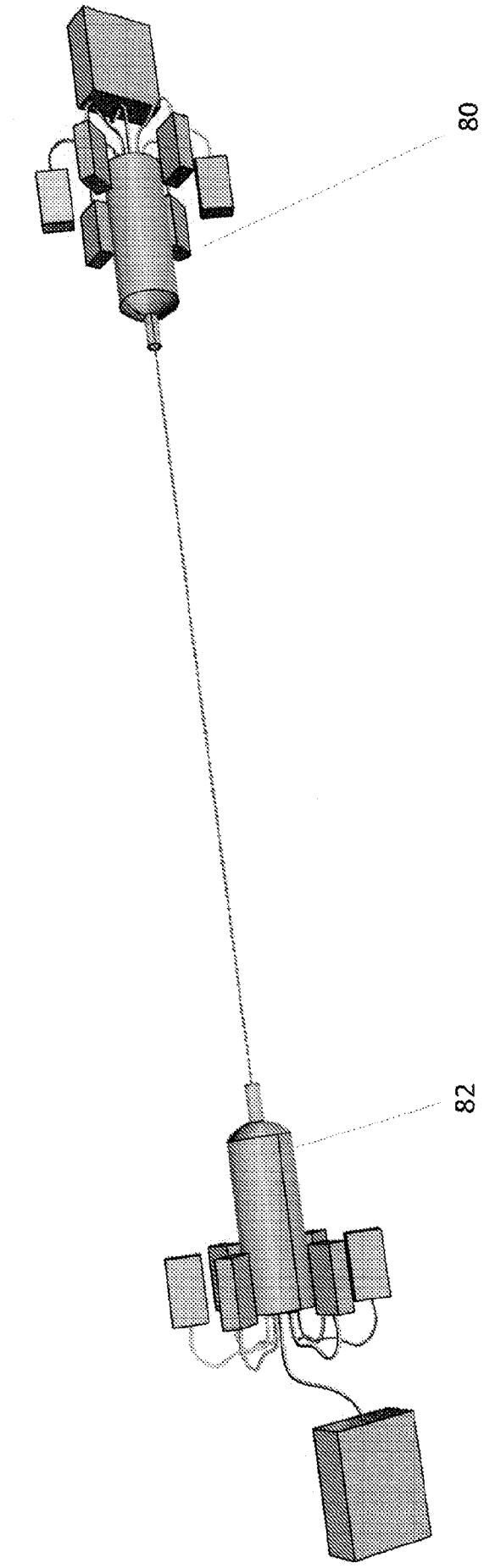

FIG. 9

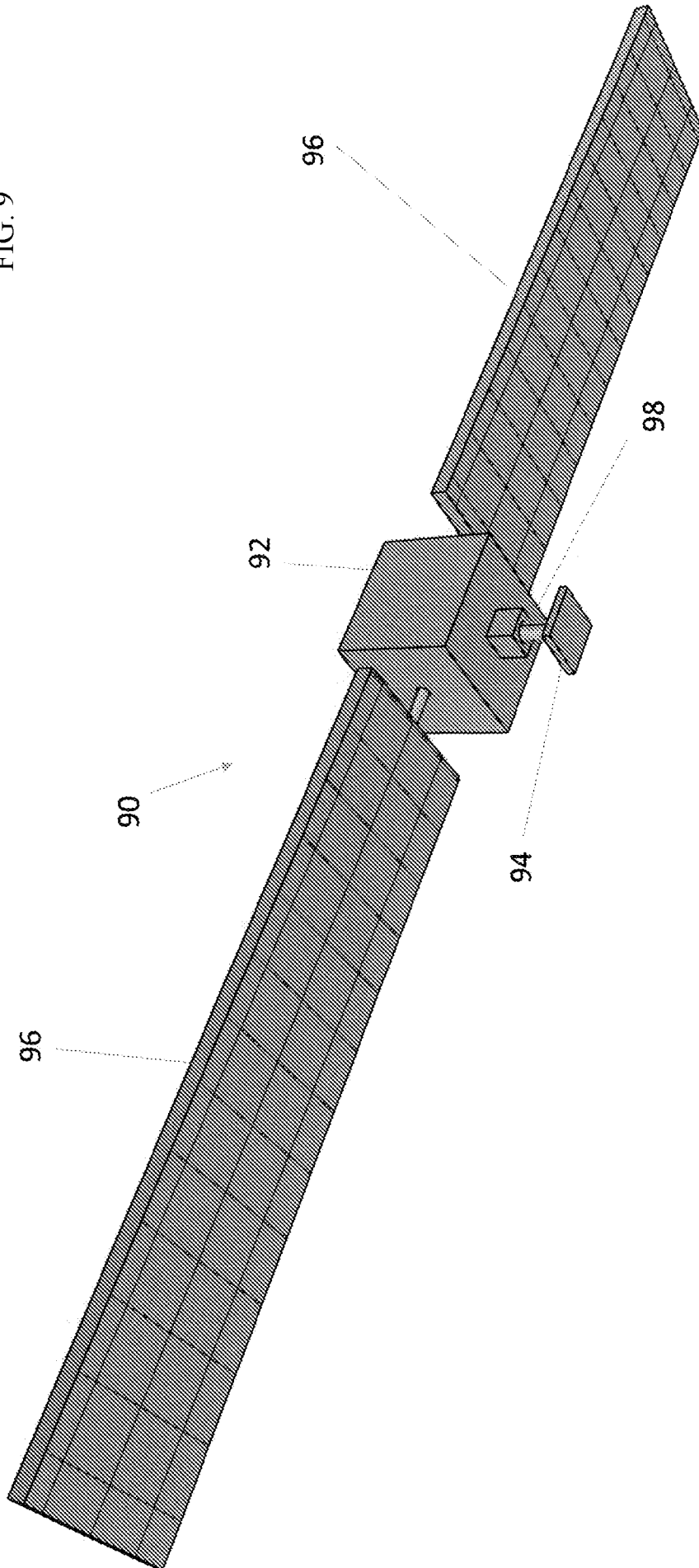

FIG. 10

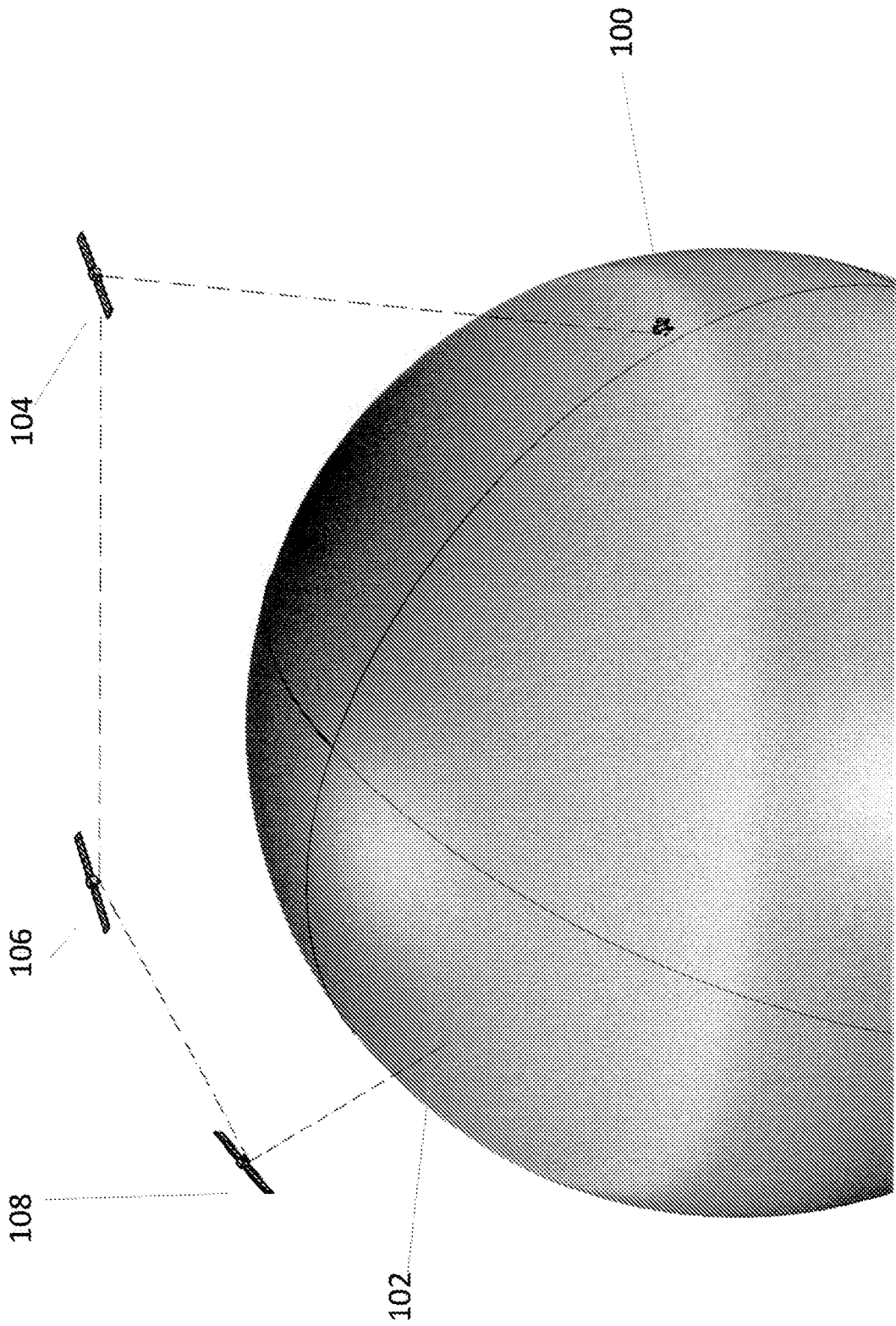

FIG. 11

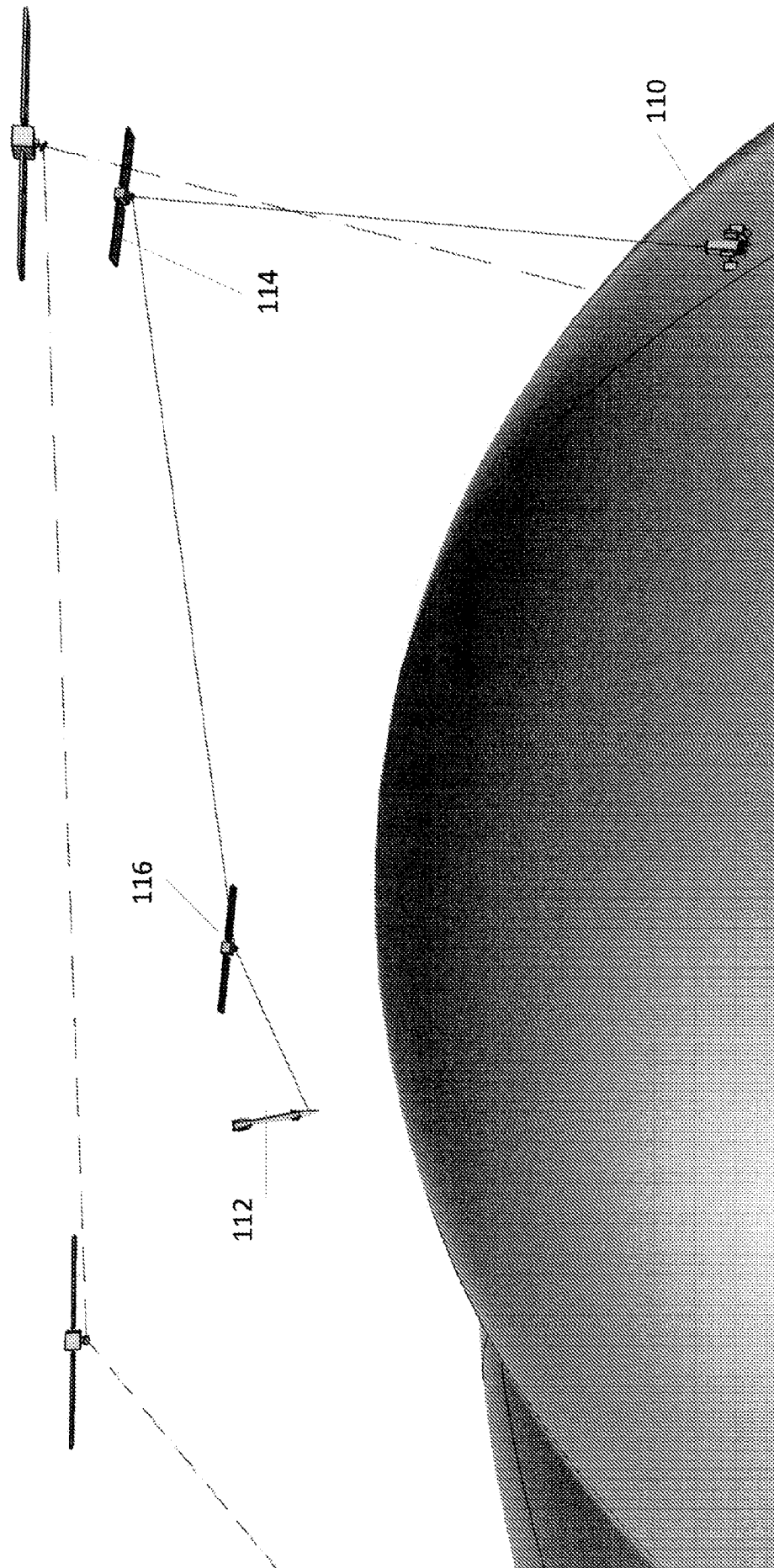

FIG. 12

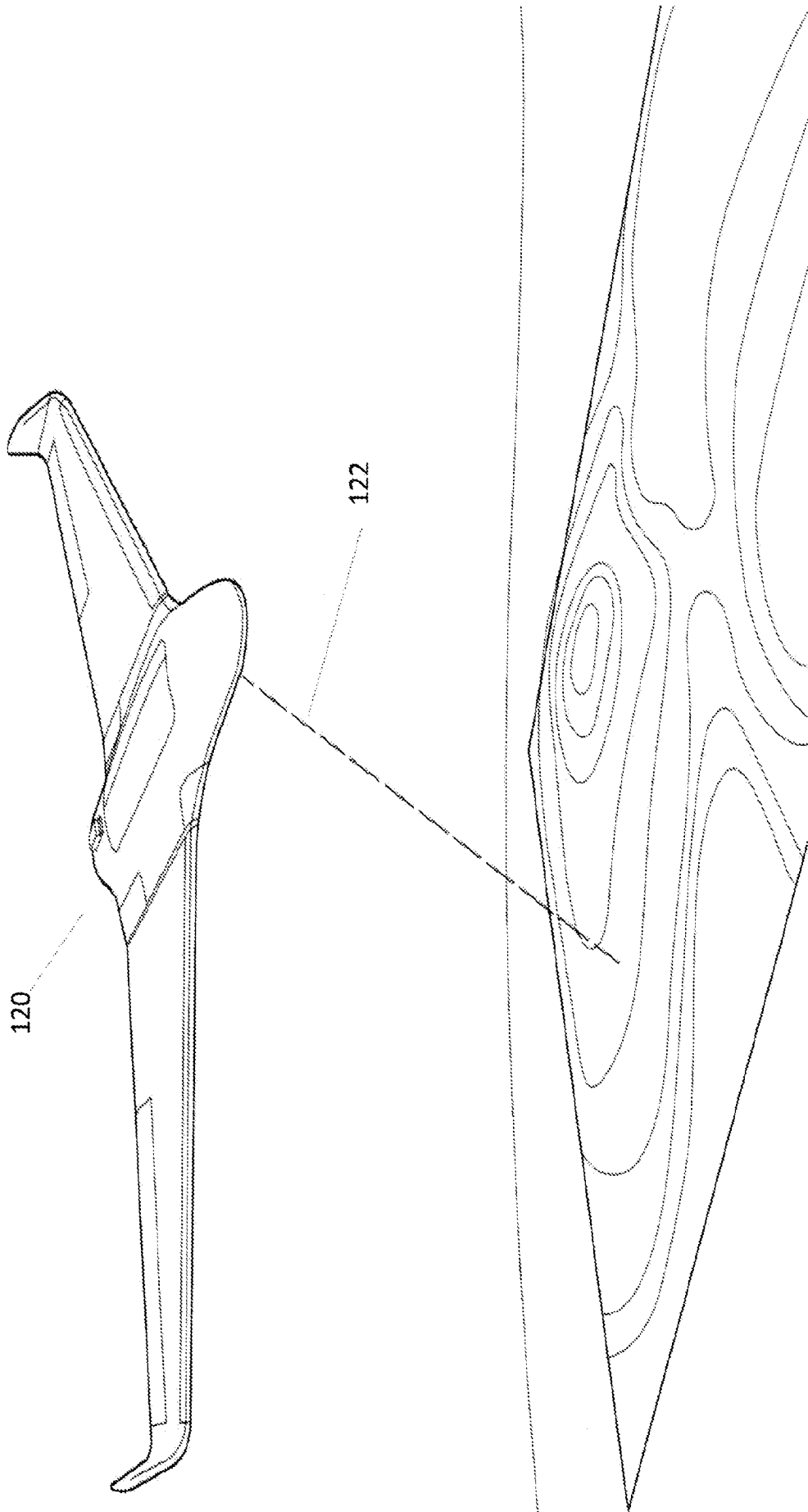

FIG. 13

130 132

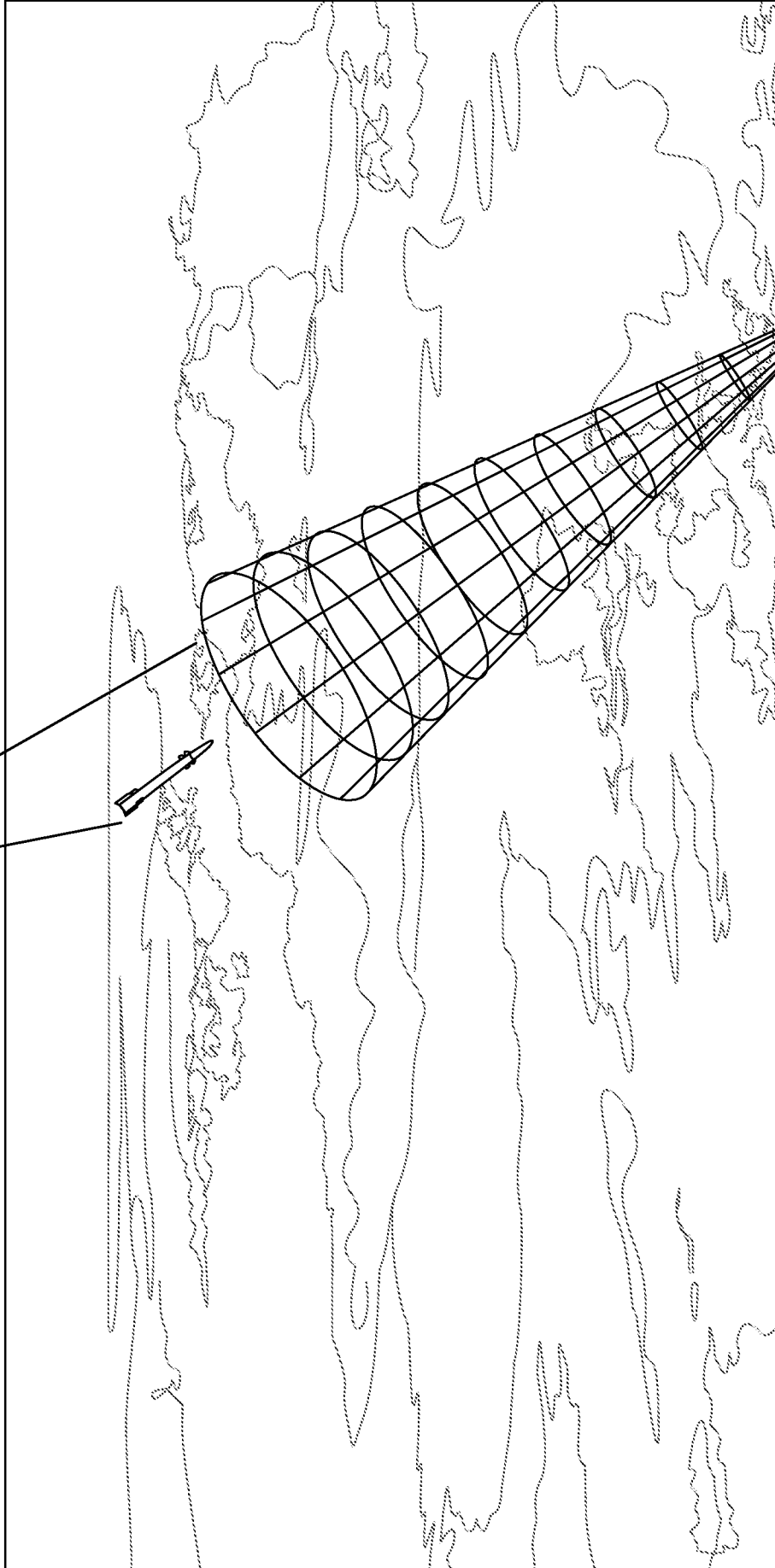
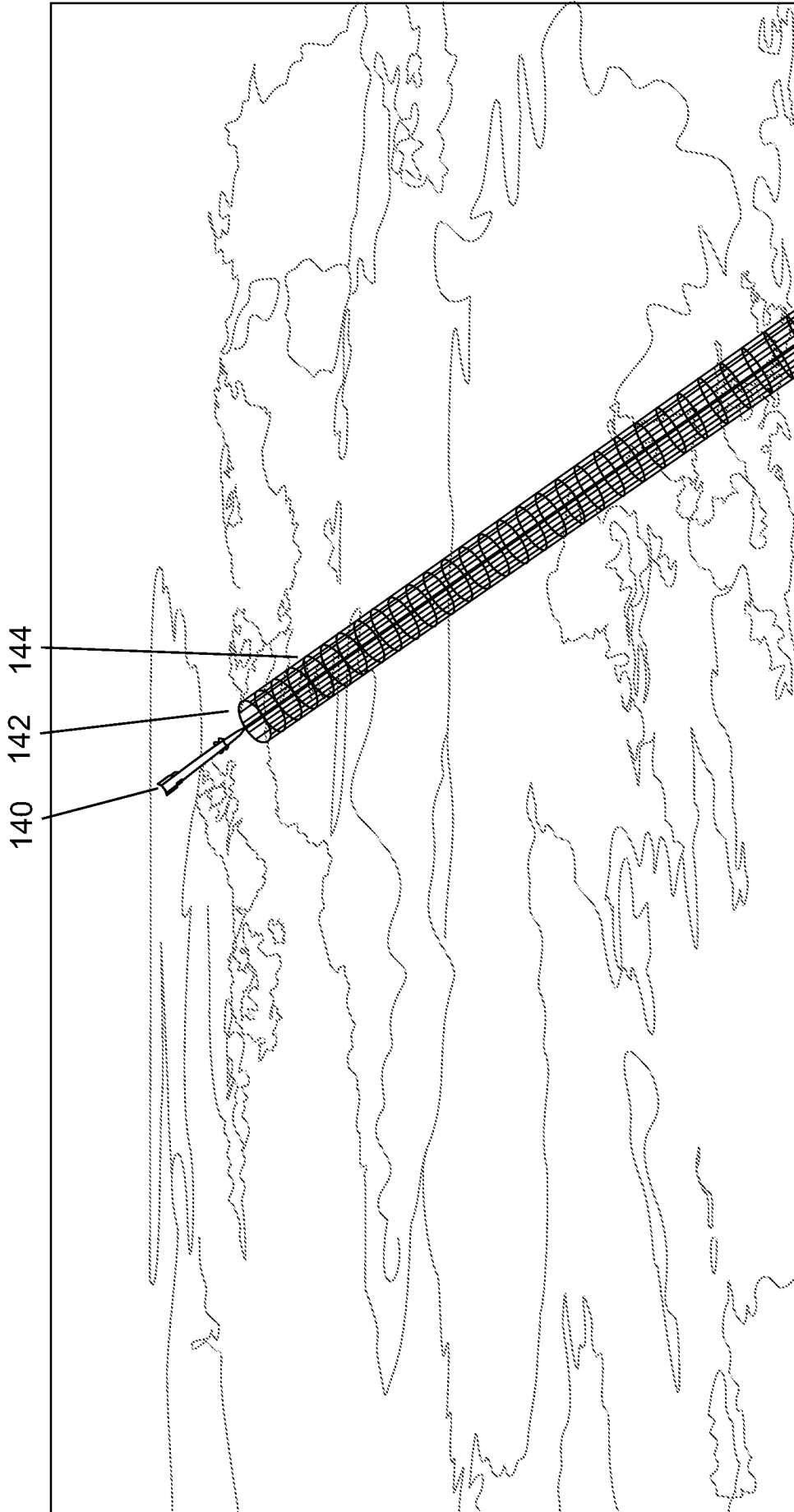

FIG. 14



## INTERNATIONAL SEARCH REPORT

International application No.

PCT/IL2021/051262

<b>A. CLASSIFICATION OF SUBJECT MATTER</b> <i>G01S 7/495</i> (2022.01)i; <i>H01S 3/23</i> (2022.01)i CPC:G01S 7/495; H01S 3/2383  According to International Patent Classification (IPC) or to both national classification and IPC		
<b>B. FIELDS SEARCHED</b>		
Minimum documentation searched (classification system followed by classification symbols) G01S 7/495; H01S 3/23 CPC:G01S 7/495; H01S 3/2383		
Documentation searched other than minimum documentation to the extent that such documents are included in the fields searched		
Electronic data base consulted during the international search (name of data base and, where practicable, search terms used) Databases consulted: Similari (AI-based) Search terms used: second/multiple/plurality wavelength, combiner, atmospheric, attenuation, missile		
<b>C. DOCUMENTS CONSIDERED TO BE RELEVANT</b>		
Category*	Citation of document, with indication, where appropriate, of the relevant passages	Relevant to claim No.
X	US 2011080311 A1 (PUSHKARSKY MICHAEL et al.) 07 April 2011 (2011-04-07) The whole document	1-32
A	US 2016139417 A1 (APPLIED MATERIALS INC. [US]) 19 May 2016 (2016-05-19) The whole document	1-32
A	US 2010215066 A1 (LUMENIS LTD. [IL]) 26 August 2010 (2010-08-26) The whole document	1-32
<input type="checkbox"/> Further documents are listed in the continuation of Box C. <input checked="" type="checkbox"/> See patent family annex.		
<p>* Special categories of cited documents:</p> <p>“A” document defining the general state of the art which is not considered to be of particular relevance</p> <p>“E” earlier application or patent but published on or after the international filing date</p> <p>“L” document which may throw doubts on priority claim(s) or which is cited to establish the publication date of another citation or other special reason (as specified)</p> <p>“O” document referring to an oral disclosure, use, exhibition or other means</p> <p>“P” document published prior to the international filing date but later than the priority date claimed</p> <p>“T” later document published after the international filing date or priority date and not in conflict with the application but cited to understand the principle or theory underlying the invention</p> <p>“X” document of particular relevance; the claimed invention cannot be considered novel or cannot be considered to involve an inventive step when the document is taken alone</p> <p>“Y” document of particular relevance; the claimed invention cannot be considered to involve an inventive step when the document is combined with one or more other such documents, such combination being obvious to a person skilled in the art</p> <p>“&amp;” document member of the same patent family</p>		
Date of the actual completion of the international search <b>23 February 2022</b>		Date of mailing of the international search report <b>23 February 2022</b>
Name and mailing address of the ISA/IL <b>Israel Patent Office Technology Park, Bldg.5, Malcha, Jerusalem, 9695101, Israel Israel</b> Telephone No. <b>972-73-3927235</b> Email: <b>pctoffice@justice.gov.il</b>		Authorized officer  <b>Kimchi Barry</b>  Telephone No.

**INTERNATIONAL SEARCH REPORT**  
**Information on patent family members**

International application No.

**PCT/IL2021/051262**

Patent document cited in search report			Publication date (day/month/year)	Patent family member(s)			Publication date (day/month/year)
US	2011080311	A1	07 April 2011	US	2011080311	A1	07 April 2011
				WO	2011043984	A1	14 April 2011
US	2016139417	A1	19 May 2016	US	2016139417	A1	19 May 2016
				US	9927622	B2	27 March 2018
				CN	103890913	A	25 June 2014
				CN	103890913	B	14 September 2016
				CN	106291950	A	04 January 2017
				CN	106291950	B	15 September 2020
				KR	20140104973	A	29 August 2014
				KR	101696055	B1	13 January 2017
				KR	20170008880	A	24 January 2017
				KR	101984759	B1	03 June 2019
				SG	11201402043V	A	26 September 2014
				TW	201345639	A	16 November 2013
				TW	I573650	B	11 March 2017
				TW	201636140	A	16 October 2016
				TW	I642507	B	01 December 2018
				US	2013163091	A1	27 June 2013
				US	8970963	B2	03 March 2015
				US	2015124329	A1	07 May 2015
				US	9285595	B2	15 March 2016
				WO	2013090581	A1	20 June 2013
US	2010215066	A1	26 August 2010	US	2010215066	A1	26 August 2010
				US	8804779	B2	12 August 2014
				AU	2003275002	A1	04 May 2004
				CA	2502699	A1	29 April 2004
				CA	2502699	C	18 December 2012
				EP	1561263	A1	10 August 2005
				EP	1561263	A4	12 April 2006
				IL	168089	A	30 June 2011
				IL	213875	D0	31 July 2011
				IL	213875	A	29 January 2015
				JP	2006503432	A	26 January 2006
				US	2007230520	A1	04 October 2007
				US	7873083	B2	18 January 2011
				US	2015009576	A1	08 January 2015
				WO	2004036705	A1	29 April 2004