



(11) **EP 2 020 649 A1**

(12) **EUROPEAN PATENT APPLICATION**

(43) Date of publication:  
**04.02.2009 Bulletin 2009/06**

(51) Int Cl.:  
**G08C 17/00 (2006.01)**

(21) Application number: **08160650.1**

(22) Date of filing: **17.07.2008**

(84) Designated Contracting States:  
**AT BE BG CH CY CZ DE DK EE ES FI FR GB GR  
HR HU IE IS IT LI LT LU LV MC MT NL NO PL PT  
RO SE SI SK TR**  
Designated Extension States:  
**AL BA MK RS**

(71) Applicant: **Mox Motion Gates S.N.C.  
di Florian Dino & C.  
31021 Mogliano Veneto (IT)**

(72) Inventor: **Florian, Dino  
31021 Frazione Bonisiolo - Mogliano Veneto (IT)**

(30) Priority: **03.08.2007 IT VE20070055**

(74) Representative: **Piovesana, Paolo et al  
Via F. Baracca, 5/a  
30173 Venezia-Mestre (IT)**

(54) **Improved portable remote control unit.**

(57) An improved portable remote control unit comprising a casing (2) housing the electronic circuit and its

powering battery (6), characterised by also comprising a photovoltaic cell element (10) for powering a rechargeable battery (6).

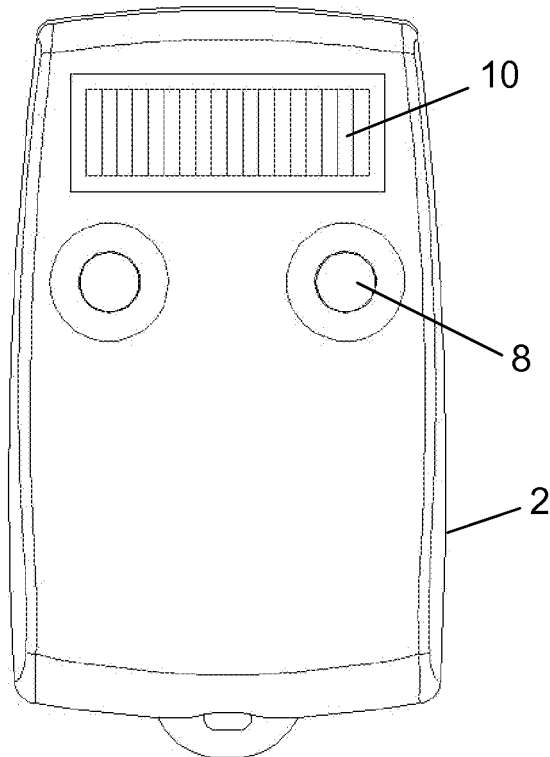

**FIG. 1**

**EP 2 020 649 A1**

## Description

[0001] The present invention relates to an improved portable remote control unit.

[0002] Known remote control units are used for the most varied apparatus requiring remote control, such as actuators for gates, alarms, accessories for the house and garden, etc.

[0003] A portable remote control unit generally comprises a plastic casing internally housing the electronic circuit and its powering battery. The casing is formed as two half-casings openable to provide access to its interior for periodic battery replacement. In some cases the battery is housed in a separate compartment of the casing, accessible from the outside via a removable door.

[0004] Independently of the form of the battery housing compartment in the remote control unit casing, two elastic blades are provided in this compartment to establish electrical connection between the battery and the electronic circuit.

[0005] A drawback of this solution is that the electrical contact between the battery and blades is often a cause of malfunction, both because of possible surface oxidation of the blades and because of uncertain mechanical connection between these and the battery.

[0006] Another drawback is that the periodic opening of the battery housing compartment results over time in an alteration in the mechanical closure system, whether this consists of snap-engagable hooks, which can wear or break with time, or of screws which over the course of time can wear the plastic threaded seat in which they engage.

[0007] Another drawback is that the state of charge of the battery is not usually indicated, meaning that the user may be unable to use the remote control unit because of a dead battery.

[0008] Another drawback is that in some cases the battery has to be replaced by a technical expert, with the resultant cost sometimes exceeding the cost of the remote control unit.

[0009] Another drawback is that the battery replacement requires disposal of the spent battery, with possible difficulty to the user.

[0010] A further drawback is that as the casing is of opening type, it is difficult to make it waterproof.

[0011] All these drawbacks are eliminated according to the invention by an improved portable remote control unit as described in claim 1.

[0012] A preferred embodiment of the present invention is described hereinafter with reference to the accompanying drawings, in which:

Figure 1 is a perspective view of an improved remote control unit according to the invention, and Figure 2 shows its basic scheme.

[0013] As can be seen from the figures, the improved remote control unit of the invention comprises a hermet-

ically sealed plastic casing 2 housing in its interior an electronic circuit 4 and a rechargeable battery 6.

[0014] One or more pushbuttons, preferably of deformable membrane type to provide casing surface continuity, are applied to a wall of the casing.

[0015] An element 10 with one or more photovoltaic cells is also applied to the casing 2, to charge the battery via a voltage regulator 12.

[0016] The connections between the various parts are preferably made by welding.

[0017] The operation of the remote control unit of the invention is apparent from the drawings. The photovoltaic cell element 10 when exposed to the light generates an electrical voltage which via the voltage regulator 12 powers the electronic circuit 4 and charges the battery 6.

[0018] At the moment of its use, the user operates the chosen pushbutton 6 which controls the electronic circuit 4, to be powered either by the battery 6 or directly by the photovoltaic cell element 10 if the battery is discharged.

[0019] From the foregoing it is apparent that the improved remote control unit of the invention presents considerable advantages compared with traditional remote control units, and in particular:

- it ensures reliable contact between the various components,
- it enables a casing to be formed which never needs to be opened and hence not only can it be sealed, but in addition excludes damage to those parts which in the casings of traditional remote control units are subject to wear and damage as a result of repeated opening and closure,
- it does not require battery replacement, hence eliminating the periodic costs of their purchase and installation, and the periodic disposal of the spent battery,
- there is no risk of non-usability of the remote controller if the battery has run down.

## Claims

1. An improved portable remote control unit comprising a casing (2) housing the electronic circuit and its powering battery (6), **characterised by** also comprising a photovoltaic cell element (10) for powering a rechargeable battery (6).
2. A remote control unit as claimed in claim 1, **characterised in that** the casing (2) is of sealed type and is provided with at least one control pushbutton (8) of elastic membrane type.
3. A remote control unit as claimed in claim 1, **characterised by** comprising a voltage regulator (12) interposed between the photovoltaic cell element (10) and the rechargeable battery (6).

4. A remote control unit as claimed in claim 1, **characterised in that** all the electrical connections are of welded type.

5

10

15

20

25

30

35

40

45

50

55

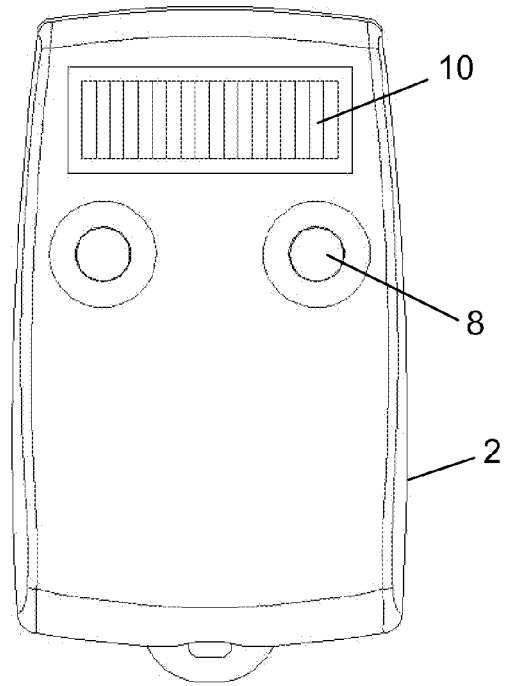

FIG. 1

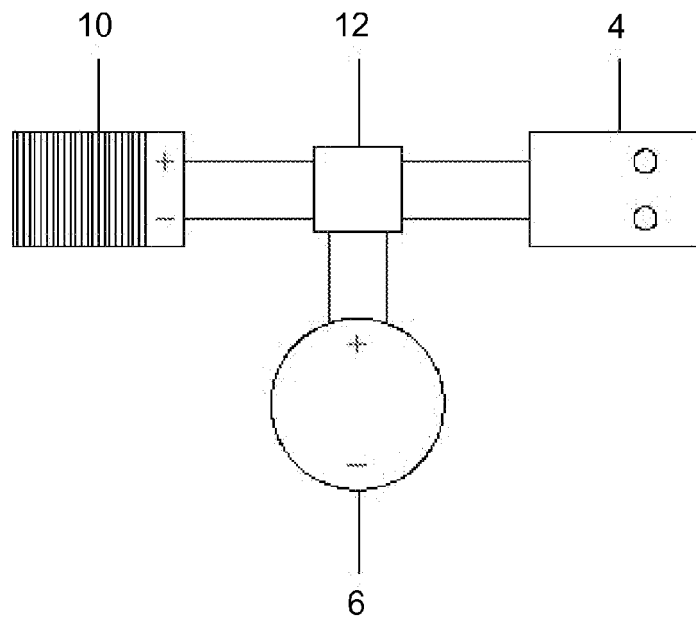

FIG. 2



EUROPEAN SEARCH REPORT

Application Number  
EP 08 16 0650

DOCUMENTS CONSIDERED TO BE RELEVANT			
Category	Citation of document with indication, where appropriate, of relevant passages	Relevant to claim	CLASSIFICATION OF THE APPLICATION (IPC)
X	DE 196 53 840 A1 (HELLA KG HUECK & CO [DE]) 25 June 1998 (1998-06-25) * column 2, line 7 - line 53 * -----	1,2	INV. G08C17/00
X	US 6 114 830 A (LUO CHING-HSING [TW]) 5 September 2000 (2000-09-05) * column 5, line 28 - column 6, line 33 * -----	1,3	
X	EP 1 484 728 A (PIACENTINI SERGIO [IT]) 8 December 2004 (2004-12-08) * paragraph [0020] - paragraph [0032] * -----	1,4	
			TECHNICAL FIELDS SEARCHED (IPC)
			G08C
The present search report has been drawn up for all claims			
Place of search The Hague		Date of completion of the search 1 December 2008	Examiner Pham, Phong
<p>CATEGORY OF CITED DOCUMENTS</p> <p>X : particularly relevant if taken alone                      Y : particularly relevant if combined with another document of the same category                      A : technological background                      O : non-written disclosure                      P : intermediate document</p> <p>T : theory or principle underlying the invention                      E : earlier patent document, but published on, or after the filing date                      D : document cited in the application                      L : document cited for other reasons                      .....                      &amp; : member of the same patent family, corresponding document</p>			

2  
EPO FORM 1503 03/82 (P04/C01)

**ANNEX TO THE EUROPEAN SEARCH REPORT  
ON EUROPEAN PATENT APPLICATION NO.**

EP 08 16 0650

This annex lists the patent family members relating to the patent documents cited in the above-mentioned European search report. The members are as contained in the European Patent Office EDP file on The European Patent Office is in no way liable for these particulars which are merely given for the purpose of information.

01-12-2008

Patent document cited in search report	Publication date	Patent family member(s)	Publication date
DE 19653840	A1	25-06-1998	NONE
US 6114830	A	05-09-2000	NONE
EP 1484728	A	08-12-2004	NONE

EPO FORM P0459

For more details about this annex : see Official Journal of the European Patent Office, No. 12/82