

June 6, 1961

W. REITZ ET AL

2,987,060

CONTINUOUS FLOW COIL TYPE HEATER

Filed Nov. 16, 1954

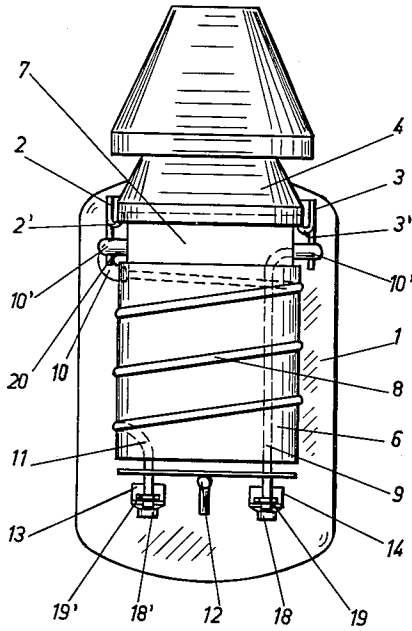

Fig. 1

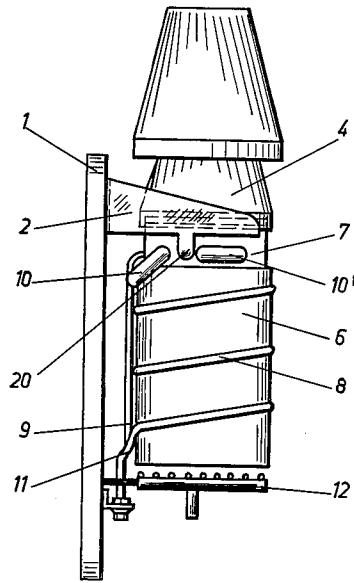

Fig. 2

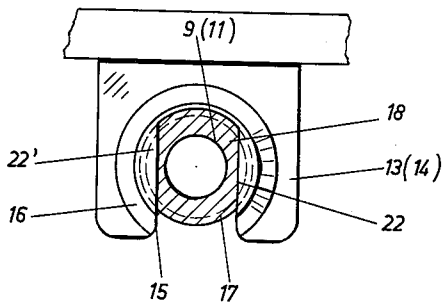

Fig. 3

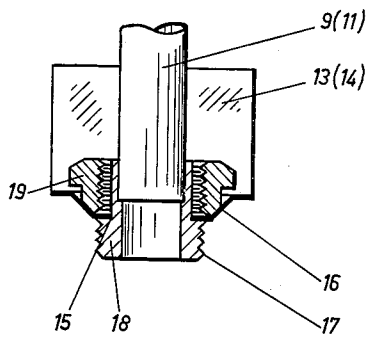

Fig. 4

Inventors

Robert Reunow  
Walter Reitz

1

2

2,987,060

## CONTINUOUS FLOW COIL TYPE HEATER

Walter Reitz, Remscheid-Hasten, and Robert Lehnartz,  
Remscheid, Germany, assignors to Joh. Vaillant K.-G.,  
Remscheid, Germany

Filed Nov. 16, 1954, Ser. No. 469,073

1 Claim. (Cl. 126-350)

This invention relates to a continuous-flow heater having a coil type heating element attached to the rear wall of the apparatus, the windings of the flow tube being conducted along and fastened, preferably soldered, to the outer face of the walls of the coil type heater. More particularly this invention relates to a reasonable fastening of the heating element which provides for a convenient assembly and dismantling of the heating element without the necessity to remove the waste gas collecting hood. Up to now special sheet metal angles attached at the wall of the heating element were used for the suspension of the heating element or the heating element has been suspended from above with its upper part in carrying brackets.

These hitherto used methods of fastening show disadvantages in various respects. If sheet metal angles to be connected with the wall of the apparatus are attached to the heater, strains may arise due to tolerances and inexactness in manufacture during subsequent connection of the flow tubes to the stationary installed pipe lines. On the other hand, suspension of the heating element to be effected from above is disadvantageous, because a disadvantageous dead space between the heating element and the waste gas collecting hood adjacent to the latter must be provided for this purpose.

According to the present invention these disadvantages are eliminated in simple manner thereby that the tube ends of the flow tube situated at the lower part of the heating element are screwed up with supporting angles which receive the weight of the heating element and are attached to the rear wall of the apparatus.

The pipe coil is that part of the heating element which shows the greatest mechanical resistance. Therefore the fastening of the heating element is most safely effected at this part. The additional advantage is offered thereby that no additional parts need to be attached to the wall of the heating element, so that material and man hours are saved.

An embodiment of the invention is illustrated in the accompanying drawings.

In the drawings:

FIG. 1 shows a front elevation of the apparatus, while

FIG. 2 represents the apparatus in side elevation.

FIG. 3 shows in enlarged representation the horizontal plan of a supporting angle.

FIG. 4 is a vertical central section through the supporting angle and the screw up attachment of the tube end.

In the embodiment selected for illustration two brackets 2, 3 are attached to the rear wall of the apparatus 1 which is manufactured of sheet metal. A waste gas collecting hood 4 rests on the inner trough shape bent rim 2', 3' of the brackets 2, 3. The waste gas collecting hood 4 stiffens simultaneously the two brackets 2, 3 against each other, so that the brackets 2, 3 are secured against lateral displacement. A pipe coil 8 is disposed in windings around a coil type heating element 6 which is closed at its upper end by a heat exchanger 7. The pipe coil 8 winding around the heating element 6 is soldered to the wall of the latter. The straight hot water supply end 9 of the pipe coil 8 is connected to the tubes penetrating the heat exchanger 7, these tubes being connected with

each other by means of elbows 10, 10', which are located outside the heat exchanger 7. The cold water inlet end of the pipe coil 8 is designated by the numeral 11. A gas burner 12 is fastened at the rear wall of the apparatus 1 below the heating element 6. The cold water fed into the cold water inlet 11 of the pipe coil 8 is in known manner heated up by the upwards moving heating gases generated by the burner 12, when the cold water passes through the pipe coil 8, through the pipes penetrating the heat exchanger 7, so that hot water is discharged from the hot water supply end 9. Two supporting angles 13, 14 provided with a recess 15, which has an opening showing towards the front, are attached with some distance from each other at the rear wall of the apparatus 1 below the gas burner 12. In addition, the projecting straps of the supporting angles 13, 14 are provided with a circular impression 16 around the recess 15. A screw sleeve 18, 18' provided with a continuous external thread 17 is firmly attached to each, the supply end 11 and the delivery end 9, of the pipe coil 8. The screw sleeve 18, 18' is milled off in its upper part so as to form flat surfaces. The width of the milled portion corresponds to the width of recess 15. A nut 19, 19' is screwed to the thread 17 of the screw sleeve 18, 18'. Projecting sheet metal noses 20, 21 are provided at the lower edge of the bracket 2, 3. The sheet metal noses 20, 21 engage at both sides between the pipe elbows 10, 10' of the heat exchanger 7.

The nuts 19, 19' are screwed upwardly as far as possible and fastening of the heating element 6 is now effected in such a manner that the tube ends 9, 11 with the milled portion of the screw sleeves 18, 18' are pushed into the recesses 15 of the supporting angles 13, 14. Under these conditions, the sheet metal noses 20, 21 engage between the pipe elbows 10, 10' and prevent tilting of the heating element from the rear wall of the apparatus towards the front. When now the nuts 19, 19' are screwed downwardly and tightened, they enter into the impression 16 and pull the segment faces 22, 22' of the screw sleeve 18, 18' from below against the supporting angles 13, 14. The heating element 6 is held in exactly defined position by this screwing up of the screw sleeves 18, 18' located at the tube ends 9, 11, the weight of the heating element being received by the supporting angles 13, 14. The connecting pipes (not represented in the drawing) can be screwed up immediately with the lower part of the screw sleeves 18, 18'. Due to the impression 16, the tube ends 9, 11 or the screw sleeves 18, 18' cannot be pulled out of the recess 15 when the nuts 19, 19' are tightened. Pulling the tube ends 9, 11 or the screw sleeves 18, 18' out of the recess 15 is only possible when the nuts 19, 19' are screwed upwards so far that they are again outside the impression 16. When removing the heating element 6 it is not required to lift it and to remove it from some suspension attachment, as is required with other known apparatus. It is only necessary to pull the heating element 6 slightly towards the front. It can then be simply removed downwardly without dismantling of the waste gas hood 4.

We claim:

A gas water heater of the continuous-flow type comprising a rear wall, a gas burner rigidly connected to the rear wall, a heating element arranged above said gas burner, said heating element carrying a continuous-flow tube system that has a hot water supply end and a cold water inlet end, said tube ends projecting said heating element, supporting members at the rear wall, means for screwing up the hot water supply end and the cold water inlet with said supporting members and means rigidly connected to the rear wall and overlapping parts of the

3

tube system to prevent tilting of the heating element from the rear wall towards the front, said overlapping means consisting of sheet metal carrying straps arranged at either side of the heating element, guide noses at said sheet metal carrying straps, said guide noses overlapping parts of the tube system, said sheet metal carrying straps provided with trough shaped lower rims which are bent towards the inside, and so attached to the rear wall that said rims lie at the level of the upper end of the heating element, and a waste gas collecting hood inserted into the bent rims of the sheet metal carrying straps.

6

10

1,462,370  
2,051,215  
2,142,019

44,150  
149,346

4

## References Cited in the file of this patent

## UNITED STATES PATENTS

Lykins ----- July 17, 1923  
Jones ----- Aug. 18, 1936  
Warner ----- Dec. 27, 1938

## FOREIGN PATENTS

Netherland ----- Sept. 17, 1938  
Switzerland ----- Nov. 16, 1931