



(12) **EUROPEAN PATENT APPLICATION**
published in accordance with Art. 158(3) EPC

(43) Date of publication:
23.02.2005 Bulletin 2005/08

(51) Int Cl.7: **B66B 13/08**

(21) Application number: **02728187.2**

(86) International application number:
PCT/JP2002/005213

(22) Date of filing: **29.05.2002**

(87) International publication number:
WO 2003/099697 (04.12.2003 Gazette 2003/49)

(84) Designated Contracting States:
**AT BE CH CY DE DK ES FI FR GB GR IE IT LI LU
MC NL PT SE TR**
Designated Extension States:
AL LT LV MK RO SI

(72) Inventor: **MORIKURA, Taiki,**
Mitsubishi Elec. Eng. Co., Ltd.
Tokyo 100-0004 (JP)

(71) Applicant: **MITSUBISHI DENKI KABUSHIKI
KAISHA**
Tokyo 100-8310 (JP)

(74) Representative: **HOFFMANN - EITL**
Patent- und Rechtsanwälte
Arabellastrasse 4
81925 München (DE)

(54) **DRIVE DEVICE FOR CIRCULAR ELEVATOR DOOR**

(57) There is provided a driving device for curved door panels (2) provided on a cylindrical elevator. The driving device includes driving links (18) for opening and closing the curved door panels (2) by a predetermined rotating operation, a door motor (5) for rotating the driv-

ing link (18), a driving pulley (10), a driven pulley (11), driving means consisting of a belt (12) and belt grippers (19, 20), a guide (13) for moving the rotation centers (B) of the driving links (18) on a predetermined path, and rollers (17).

Fig. 1

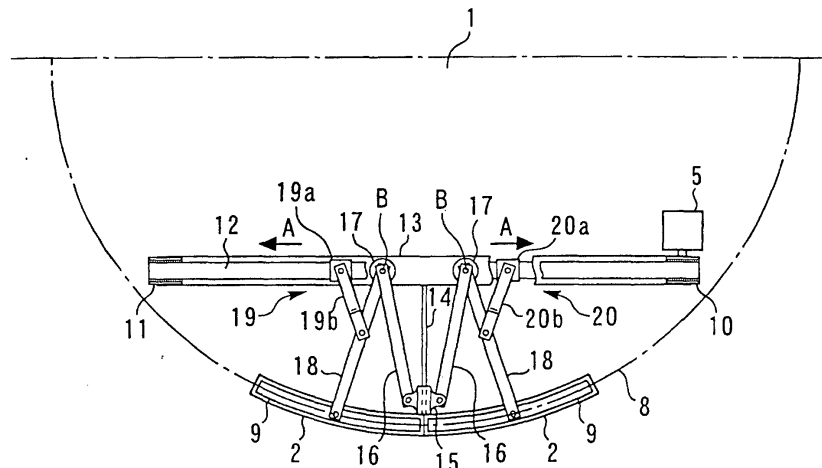

Description

Technical Field

[0001] The present invention relates to a cylindrical elevator door driving device.

Background Art

[0002] Generally, a panel of an elevator cage door is formed by a plane, and the cage door is opened and closed by straight movement in the right-and-left direction. In recent years, however, the interior design of buildings has been diversified, and accordingly, cylindrical elevators having a cylindrical cage(s) have been used. In this cylindrical elevator, the cage door is formed so as to be a part of the cylindrical cage to match the shape of the cage, and thus the cross-sectional shape of the cage door of a plane perpendicular to the elevating direction is arcuate. That is, the cylindrical elevator door that is opened and closed to the right and left along an arcuate path is used as a cage door. One example of such a cylindrical elevator is described in Japanese unexamined utility model laid-open No. 52-56862.

[0003] Figure 4 is a schematic view showing one example of a basic construction of a door opening/closing driving device for a cylindrical elevator. The cylindrical elevator door is made up of a curved door panel, a door hanger for hanging an upper part of the door, a door rail, a sill for guiding a lower part of the door, and the like. The curved door panel is opened and closed by a driving device provided on the ceiling of the cage and a linkage that moves in association with the driving device.

[0004] A specific construction of the cylindrical elevator door driving device will be described with reference to Figure 4. Curved door panels 102 are provided on the outside of a cylindrical cage 101 so as to be slidable along the outer peripheral surface of the cage 101 by means of a door rail. On the right and left curved door panels 102, driving links 104 are provided symmetrically. The driving link 104 is a linkage for driving the curved door panel 102. One end of the driving link 104 is connected to a supporting point C, which is the rotation center of the curved door panel 102 and also the center of the cage 101, and the other end thereof is connected to an upper part of the curved door panel 102 via a small link 103.

[0005] In a fan-shaped space formed by the two driving links 104, a door motor 105 and a speed reducing pulley 106 are arranged. The door motor 105 and the speed reducing pulley 106 are fixed on the top of the cage 101, and an outer peripheral portion of the speed reducing pulley 106 and an intermediate portion of the driving link 104 are connected to each other by a connecting rod 107.

[0006] In the cylindrical elevator door driving device constructed as described above, when the door motor 105 is rotated, the speed reducing pulley 106 is rotated,

and the driving links 104 turned around the supporting point C by the connecting rods 107 open or close the right and left curved door panels 102 at the same time.

[0007] However, the conventional door opening/closing driving device for cylindrical elevator has problems as described below.

[0008] First of all, since the center of the cylindrical cage 101 coincides with the rotation center (supporting point C) of the driving link 104, the length of the driving link 104 must be changed according to the size of the cage 101. Therefore, each element such as the driving link 104, the small link 103, the door motor 105, the speed reducing pulley 106, and the connecting rod 107 must be redesigned each time the size of the cage 101 is changed. This presents a problem in that much redesign time is consumed, and hence the manufacturing cost increases.

[0009] Also, the sizes of the door motor 105 and the speed reducing pulley 106 must be larger than the fixed sizes to obtain a predetermined driving force, and thus the miniaturization thereof has a limit. However, in the conventional driving device, it is difficult to arrange the elements in a region other than the fan-shaped space formed by the two driving links 104 because of a constructional restriction such that the rotation center of the driving link 104 is caused to coincide with the center of the cylindrical cage 101. Therefore, when the cage 101 is small, it is difficult to arrange the driving elements such as the door motor 105 and the speed reducing pulley 106.

[0010] Also, in the case where the center of the cylindrical cage 1 coincides with the rotation center of the driving link 104, a planar space occupied by the elements for the driving device is about a half of a planar space occupied by the cage 101, as shown in Figure 4. Therefore, when the size of the cage 101 becomes large, the sizes of the elements such as the driving link 104, the door motor 105, the speed-reducing pulley 106, and the connecting rod 107 are made large, and thus the driving device itself becomes a large unit. Accordingly, there arises problems of increased unit weight and increased unit cost.

[0011] Furthermore, in the case where the center of the cylindrical cage 1 coincides with the rotation center of the driving link 104, the opening/closing operation of the curved door panel 102 cannot be performed smoothly unless both of the centers are caused to coincide with each other with high accuracy. For this reason, it is difficult to perform work for truing up both of the centers at the time of assembly or at the time of installation. Therefore, the workability at the installation time decreases remarkably, which results in an increase in cost.

[0012] Accordingly, an object of the present invention is to provide a cylindrical elevator door driving device which can be applied to various cage sizes, can be installed on a space-saving and small-size cage, and has high workability in assembly and installation.

Disclosure of the Invention

[0013] According to an aspect of the invention, there is provided a cylindrical elevator door driving device which is provided on a cylindrical elevator, comprising a driving link for opening and closing a cylindrical elevator door by a predetermined rotating operation, a driving means for rotating the driving link, and a moving means for moving the rotation center of the driving link on a predetermined path. Since the rotation center of the driving link is moved, the rotation center need not be arranged at the center of the cylindrical elevator. For this reason, the driving device can be provided only in a limited portion of the planar region of a cage without being restricted by the cage size. Therefore, the driving device can be applied to various cage sizes, and the space for the driving device can be saved. Further, the centering work for arranging the rotation center at the center of the cylindrical elevator is unnecessary, so the workability in assembly and installation can be improved significantly. The driving means for turning the driving link and the moving means for moving the rotation center may be a driving source, such as a motor, itself, or may include a link mechanism, belt mechanism, gear, and pulley for transmitting the operation of the driving source. Also, the moving means may be a guide member for regulating the path of rotation center, and the rotation center may be moved by the operation of the driving means.

[0014] According to another aspect of the invention, in the improved elevator door driving device of the aforementioned invention, the moving means has a guide member provided along the path on which the rotation center of the driving link moves the sliding member along the guide member. By moving the sliding member along the guide member, the rotation center of the driving link can surely be moved on a predetermined path. Also, since the driving link is turned by the driving means and the rotation center is moved simultaneously, the unit construction can be simplified.

[0015] According to another aspect of the invention, in the improved cylindrical elevator door driving device of the aforementioned invention, the guide member is provided at a position closer to said cylindrical elevator door than to the center of the cylindrical elevator. Since the guide member is provided at a position close to the cylindrical elevator door, the driving unit can be arranged in only a region near the cylindrical elevator door, so space saving can be attained, and also the driving unit can be applied to a small cage.

[0016] According to another aspect of the invention, in the improved cylindrical elevator door driving device of the aforementioned invention, the moving means moves the rotation centers of driving links corresponding to the two cylindrical elevator doors symmetrically in the direction that the cylindrical elevator doors move. Even in the case where two cylindrical elevator doors that open and close symmetrically in the right-and-left

direction are provided, by moving the rotation center of the driving link symmetrically in the direction such that the cylindrical elevator doors move, the driving device can be applied to various cage sizes, and space saving can be attained.

[0017] According to another aspect of the invention, in the improved cylindrical elevator door driving device of the aforementioned invention, the driving means has a driving shaft connected to a driving source, a driven shaft, a belt which is set around the driving shaft and the driving shaft is moved along with the rotation of the driving shaft, and belt gripping members mounted at predetermined positions on the forward side and the backward side of the belt, the driving links corresponding to the two cylindrical elevator doors are connected to the belt gripping members on the forward side and the backward side of the belt, and the rotation centers of the driving links are moved symmetrically in the direction that the cylindrical elevator doors move by the movement of the belt. By connecting the driving links to the belt gripping members on the forward side and the backward side of the belt, the rotation centers of the driving links can be moved symmetrically in the direction that the cylindrical elevator doors move by the movement of the belt.

[0018] According to another aspect of the invention, the improved cylindrical elevator door driving device of the aforementioned invention has a link member, of which one end is connected to the rotation center of the driving link corresponding to each of the two cylindrical elevator doors, a slider rail provided along the symmetrical axis of the movement paths of the two cylindrical elevator doors, and a slider which moves along the slider rail and to which the other end of the link member is connected. By moving the slider along the symmetry axis of the movement paths of the cylindrical elevator doors and by connecting the slider to the rotation center of the driving link by the link member, both of the rotation centers of the driving links can be moved symmetrically in the right-and-left direction. Thereby, the two cylindrical elevator doors can be moved symmetrically with high accuracy.

Brief Description of the Drawings

[0019]

Figure 1 is a plan view of a cylindrical elevator door driving device in accordance with an embodiment of the present invention, showing a state in which curved door panels are fully closed.

Figure 2 is a side view of a cylindrical elevator door driving device in accordance with an embodiment of the present invention.

Figure 3 is a plan view of a cylindrical elevator door driving device in accordance with an embodiment of the present invention, showing a state in which curved door panels are fully opened.

Figure 4 is a plan view of a conventional cylindrical elevator door driving device.

Best Mode for Carrying Out the Invention

[0020] Figures 1, 2 and 3 are schematic views of a cylindrical elevator door driving device in accordance with an embodiment of the present invention. Figure 1 is a plan view showing a state in which curved door panels are fully closed, and Figure 3 is a plan view showing a state in which curved door panels are fully opened. Figure 2 is a side view of a driving device viewed from the outside of a cage 1 in the lengthwise direction of a slider rail 14 shown in Figure 1.

[0021] First of all, the construction of the cylindrical elevator door driving device will be described with reference to Figures 1 and 2. As shown in Figures 1 and 2, curved door panels 2 are provided on the outside of the cylindrical cage 1. The curved door panel 2 is hung by a door hanger 9 that is hung from a door rail 8, and is provided so as to be slidable along the door rail 8.

[0022] On the cage center side of the curved door panel 2 there are provided a door motor 5, a driving pulley 10 installed on the output shaft of the door motor 5, and a driven pulley 11, and a belt 12 is set around the driving pulley 10 and the driven pulley 11.

[0023] A guide 13 is provided along the belt 12, and rollers 17 that slide along the guide 13 are provided. Also, a slider rail 14 is provided along the symmetrical axis of the movement paths of the two curved door panels 2, and the slider rail 14 is inserted through a slider 15. Therefore, the slider 15 moves along the slider rail 15.

[0024] The slider 15 is connected to the roller 17 via a link 16. Specifically, one end of the link 16 is pin-connected to the slider 15 so as to be turned with respect to the slider 15, and the other end thereof is pin-connected to the roller 17.

[0025] Also, the roller 17 is connected to the door hanger 9 via a link 18. One end of the link 18 is pin-connected to the roller 17, and the other end thereof is pin-connected to the door hanger 9.

[0026] The belt 12 is mounted with belt grippers 19 and 20. As shown in Figure 2, the belt gripper 19 is mounted on the upper side of the belt 12, and the belt gripper 20 is mounted on the lower side of the belt 12. Therefore, when the belt 12 is moved in a fixed direction, the belt gripper 19 and the belt gripper 20 move in the direction opposite to each other. The belt gripper 19, 20 includes a belt gripper body 19a, 20a fixed to the belt 12 and a link portion 19b, 20b. One end of the link portion 19b, 20b is pin-connected to the belt gripper body 19a, 20a, and the other end of the link portion 19b, 20b is pin-connected to a portion near the central portion of the link 18.

[0027] Next, the opening/closing operation of the curved door panel 2 of the cylindrical elevator door driving device constructed as described above will be described with reference to Figures 1 and 3.

[0028] In a fully closed state shown in Figure 1, when an opening/closing signal is received from a control unit, the door motor 5 is rotated, and hence the driving pulley 10 is rotated. Thereby, the belt 12 that is set between the driving pulley 10 and the driven pulley 11 is moved in the direction indicated by arrow A in Figure 1.

[0029] Then, the left and right belt gripper bodies 19a and 20a mounted on the belt 12 move in the direction indicated by arrow A. Thereby, the link portions 19b and 20b, of which one end is pin-connected to the belt gripper bodies 19a and 20a, are moved so as to be opened toward the outside of the cage 1, so that the left and right links 18 are moved in the direction such that the right and left links 18 are opened toward the outside of the cage 1. The link 18 turns around the rotation center B in the door opening direction while the roller 17, on which the rotation center B is located, is moved toward the outside of the cage 1 along the guide 13. The rotational force of the link 18 is transmitted to the door hanger 9, so that the door panel 2 is moved in the door opening direction while drawing an arc along the door rail 8 as shown in Figure 3.

[0030] When the rollers 17 move toward the outside along the guide 13, the links 16 move the slider 15 toward the center of the cage 1. Since the two rollers 17 are connected to the slider 15 via the links 18, the distance between each of the rollers 17 and the slider rail 14 is equal. Therefore, the degrees of opening of the left and right curved door panels 2 can be made equal.

[0031] When the curved door panels 2 move along the door rail 8 and reach a fully open state shown in Figure 3, the rotation of the door motor 5 is stopped by a command from the control unit.

[0032] When the curved door panels 2 are closed from the fully open state shown in Figure 3, the door motor 5 is rotated in the direction opposite to that in the above-described case, by which the belt 12 is moved in the direction opposite to the direction indicated by arrow A. Thereby, the curved door panels 2 are closed by the operation reverse to the above.

[0033] As described above, according to this embodiment, since the rotation center A of the link 18 is moved near the curved door panel 2, the whole of the driving device can be arranged only in a region near the curved door panel 2. Also, since the rotation center of the driving link 18 need not be arranged at the center of the cylindrical cage 1, the size, shape, arrangement, etc. of element of the driving device are not restricted by the size of the cage 1. Therefore, even if the size of the cage 1 is changed, a common driving device can be used, and hence the degree of freedom in designing a cylindrical elevator can be enhanced significantly.

[0034] Also, since the driving device is arranged in a front portion on the entrance side on the ceiling of the cage 1, the space factor can be improved. That is, even if the elevator is small in size, the driving device can be arranged leaving some surplus of space.

[0035] Also, since the rotation centers B of the right

and left driving links 4 are independent of each other, even in the case where the accuracies of the right and left driving devices are different from each other, assembly and installation can be accomplished easily by individually adjusting the position of the center B.

5

Industrial Application

[0036] As described above, the cylindrical elevator door driving device in accordance with the present invention can be applied to various cage sizes without design change, can be installed even on a space-saving and small-size cage, and has high workability in assembly and installation, so it is useful for various types of cylindrical elevators.

10

15

Claims

1. A cylindrical elevator door driving device which is provided on a cylindrical elevator, **characterized by** comprising:

20

a driving link for opening and closing a cylindrical elevator door by a predetermined rotating operation;

25

driving means for rotating said driving link; and moving means for moving the rotation center of said driving link on a predetermined path.

30

2. The cylindrical elevator door driving device according to claim 1, **characterized in that:**

said moving means has a guide member provided along the path on which the rotation center of said driving link moves and a sliding member provided at the rotation center of said driving link; and

35

said driving means turns said driving link and moves said sliding member along said guide member.

40

3. The cylindrical elevator door driving device according to claim 2, **characterized in that** said guide member is provided at a position closer to said cylindrical elevator door than from the center of said cylindrical elevator.

45

4. The cylindrical elevator door driving device according to any one of claims 1 to 3, **characterized in that** said moving means moves the rotation centers of driving links corresponding to said two cylindrical elevator doors symmetrically in the direction that said cylindrical elevator doors move.

50

55

5. The cylindrical elevator door driving device according to claim 4, **characterized in that:**

said driving means has a driving shaft connected to a driving source, a driven shaft, a belt which is set around said driving shaft and said driven shaft is moved along with the rotation of said driving shaft, and belt gripping members mounted at predetermined positions on the forward side and the backward side of said belt:

said driving links corresponding to said two cylindrical elevator doors are connected to said belt gripping members on the forward side and the backward side of said belt; and

the rotation centers of said driving links are moved symmetrically in the direction such that said cylindrical elevator doors move by the movement of said belt.

6. The cylindrical elevator door driving device according to claim 4 or 5, **characterized by** further comprising:

a link member of which one end is connected to the rotation center of said driving link corresponding to each of said two cylindrical elevator doors;

a slider rail provided along the symmetrical axis of the movement paths of said two cylindrical elevator doors; and

a slider moving along said slider rail and having the other end of said link member connected thereto.

Fig. 1

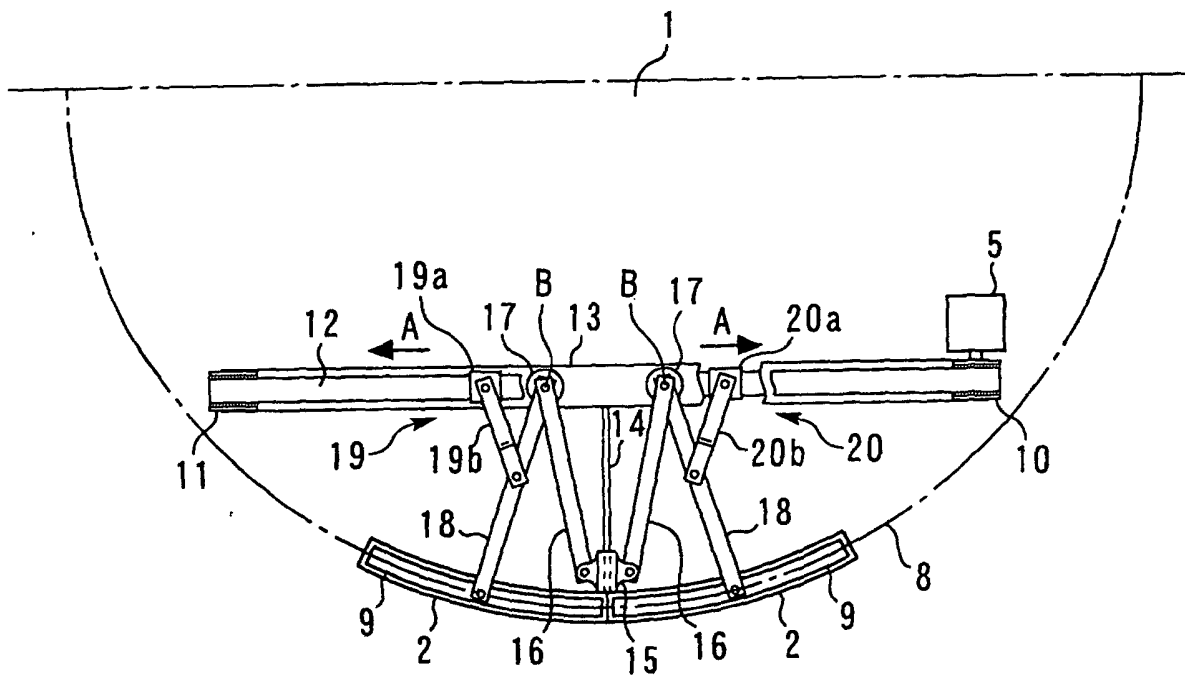

Fig. 2

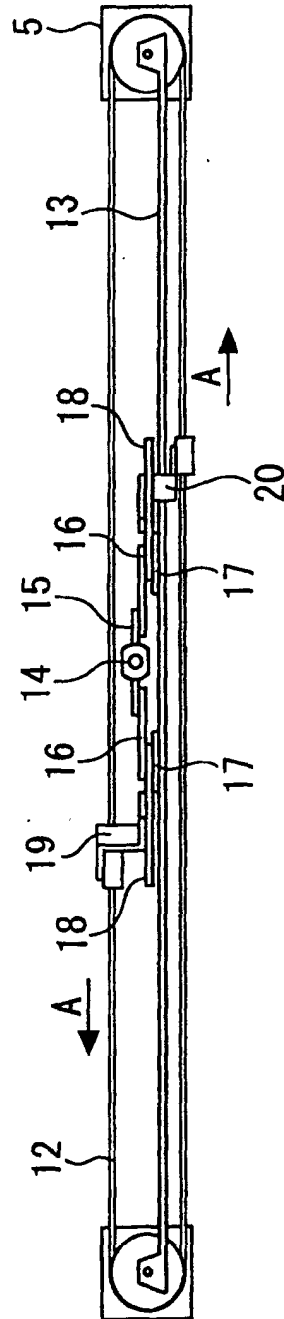

Fig. 3

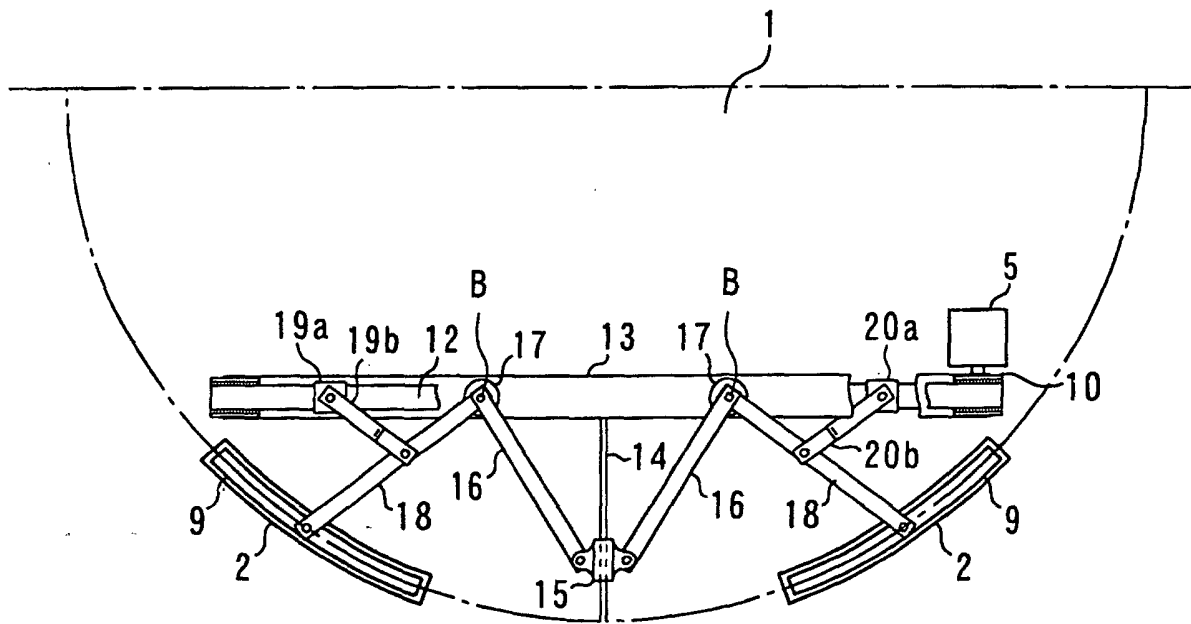
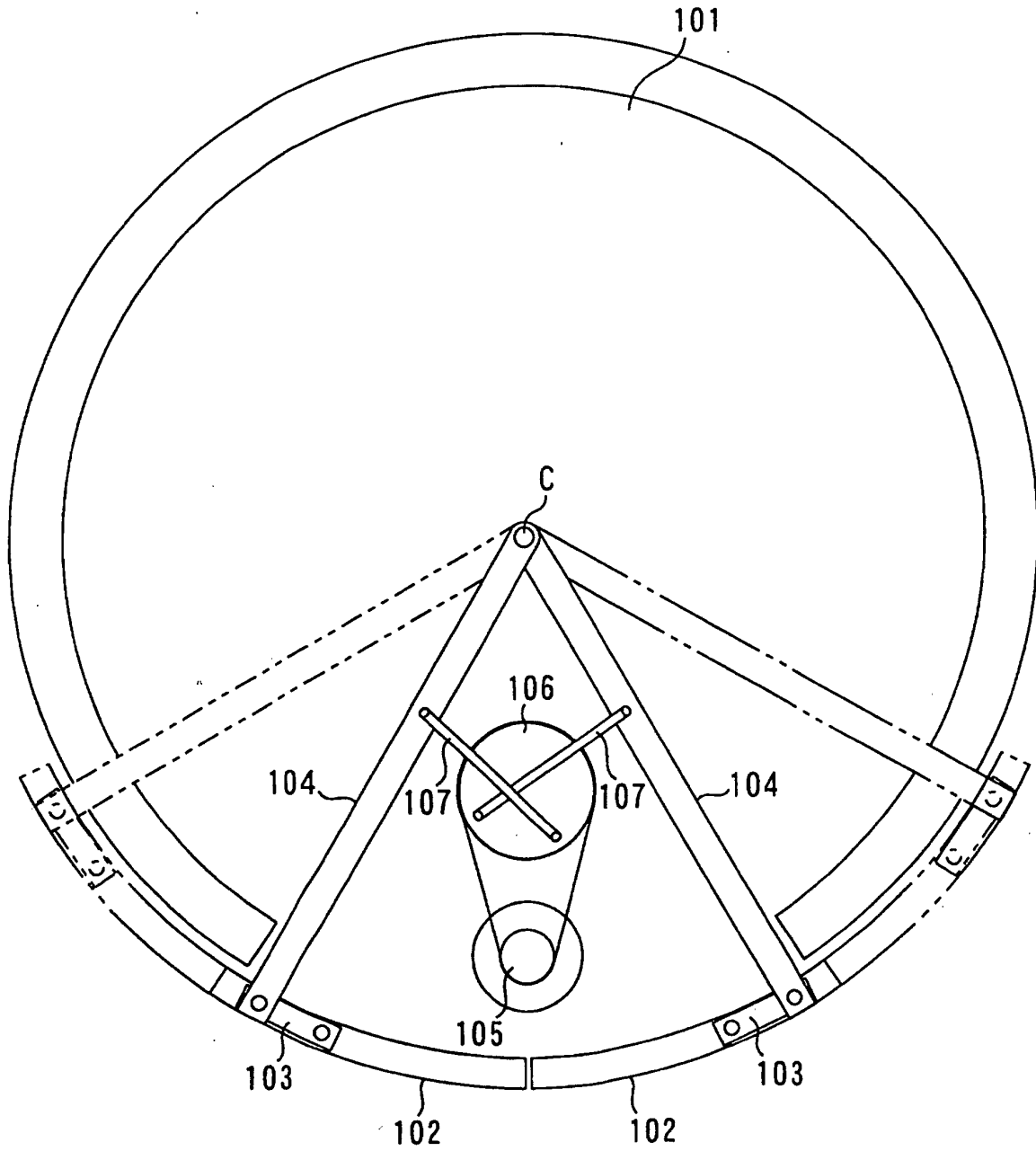

Fig. 4



INTERNATIONAL SEARCH REPORT

International application No.

PCT/JP02/05213

<p>A. CLASSIFICATION OF SUBJECT MATTER Int.Cl⁷ B66B13/08</p> <p>According to International Patent Classification (IPC) or to both national classification and IPC</p>																				
<p>B. FIELDS SEARCHED</p> <p>Minimum documentation searched (classification system followed by classification symbols) Int.Cl⁷ B66B13/00~B66B13/30</p> <p>Documentation searched other than minimum documentation to the extent that such documents are included in the fields searched Jitsuyo Shinan Koho 1922-1996 Jitsuyo Shinan Toroku Koho 1996-2003 Kokai Jitsuyo Shinan Koho 1971-2003 Toroku Jitsuyo Shinan Koho 1994-2003</p> <p>Electronic data base consulted during the international search (name of data base and, where practicable, search terms used)</p>																				
<p>C. DOCUMENTS CONSIDERED TO BE RELEVANT</p> <table border="1"> <thead> <tr> <th>Category*</th> <th>Citation of document, with indication, where appropriate, of the relevant passages</th> <th>Relevant to claim No.</th> </tr> </thead> <tbody> <tr> <td>X Y A</td> <td>JP 55-16924 Y2 (Fujitec Co., Ltd.), 19 April, 1980 (19.04.80), & JP 53-90372 U</td> <td>1, 4-5 2-3 6</td> </tr> <tr> <td>X Y A</td> <td>JP 2-7168 Y2 (Nippon Air Brake Co., Ltd.), 21 February, 1990 (21.02.90), & JP 57-187379 U</td> <td>1 2-3 6</td> </tr> <tr> <td>Y A</td> <td>JP 7-43107 Y2 (Toshiba Corp.), 04 October, 1995 (04.10.95), & JP 2-49976 U</td> <td>2-3 6</td> </tr> </tbody> </table> <p><input type="checkbox"/> Further documents are listed in the continuation of Box C. <input type="checkbox"/> See patent family annex.</p> <p>* Special categories of cited documents: "A" document defining the general state of the art which is not considered to be of particular relevance "E" earlier document but published on or after the international filing date "L" document which may throw doubts on priority claim(s) or which is cited to establish the publication date of another citation or other special reason (as specified) "O" document referring to an oral disclosure, use, exhibition or other means "P" document published prior to the international filing date but later than the priority date claimed "T" later document published after the international filing date or priority date and not in conflict with the application but cited to understand the principle or theory underlying the invention "X" document of particular relevance; the claimed invention cannot be considered novel or cannot be considered to involve an inventive step when the document is taken alone "Y" document of particular relevance; the claimed invention cannot be considered to involve an inventive step when the document is combined with one or more other such documents, such combination being obvious to a person skilled in the art "&" document member of the same patent family</p> <table border="1"> <tr> <td>Date of the actual completion of the international search 14 February, 2003 (14.02.03)</td> <td>Date of mailing of the international search report 04 March, 2003 (04.03.03)</td> </tr> <tr> <td>Name and mailing address of the ISA/ Japanese Patent Office</td> <td>Authorized officer</td> </tr> <tr> <td>Facsimile No.</td> <td>Telephone No.</td> </tr> </table>			Category*	Citation of document, with indication, where appropriate, of the relevant passages	Relevant to claim No.	X Y A	JP 55-16924 Y2 (Fujitec Co., Ltd.), 19 April, 1980 (19.04.80), & JP 53-90372 U	1, 4-5 2-3 6	X Y A	JP 2-7168 Y2 (Nippon Air Brake Co., Ltd.), 21 February, 1990 (21.02.90), & JP 57-187379 U	1 2-3 6	Y A	JP 7-43107 Y2 (Toshiba Corp.), 04 October, 1995 (04.10.95), & JP 2-49976 U	2-3 6	Date of the actual completion of the international search 14 February, 2003 (14.02.03)	Date of mailing of the international search report 04 March, 2003 (04.03.03)	Name and mailing address of the ISA/ Japanese Patent Office	Authorized officer	Facsimile No.	Telephone No.
Category*	Citation of document, with indication, where appropriate, of the relevant passages	Relevant to claim No.																		
X Y A	JP 55-16924 Y2 (Fujitec Co., Ltd.), 19 April, 1980 (19.04.80), & JP 53-90372 U	1, 4-5 2-3 6																		
X Y A	JP 2-7168 Y2 (Nippon Air Brake Co., Ltd.), 21 February, 1990 (21.02.90), & JP 57-187379 U	1 2-3 6																		
Y A	JP 7-43107 Y2 (Toshiba Corp.), 04 October, 1995 (04.10.95), & JP 2-49976 U	2-3 6																		
Date of the actual completion of the international search 14 February, 2003 (14.02.03)	Date of mailing of the international search report 04 March, 2003 (04.03.03)																			
Name and mailing address of the ISA/ Japanese Patent Office	Authorized officer																			
Facsimile No.	Telephone No.																			