

No. 829,474.

PATENTED AUG. 28, 1906.

M. P. C. HOOPER.  
LOOM.

APPLICATION FILED AUG. 20, 1902.

2 SHEETS—SHEET 1.

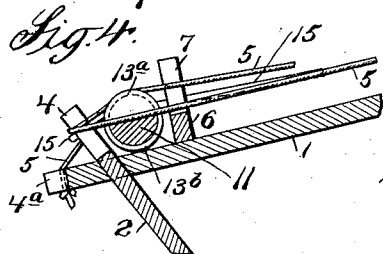
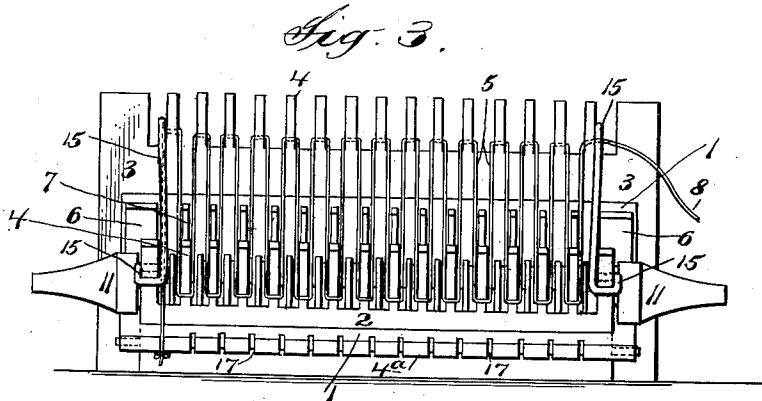
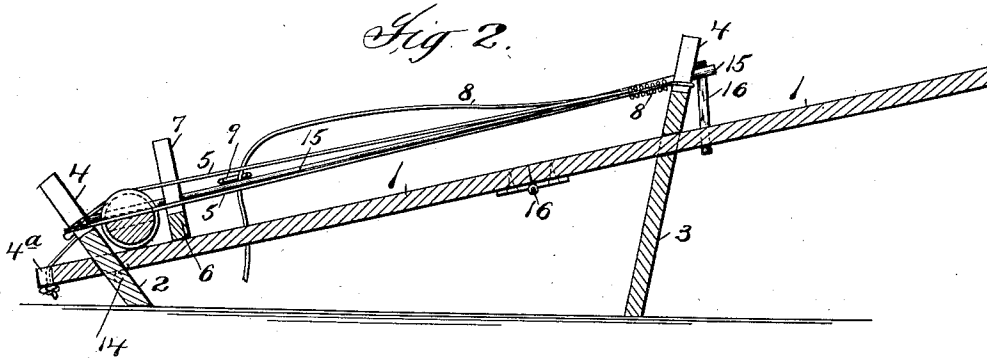
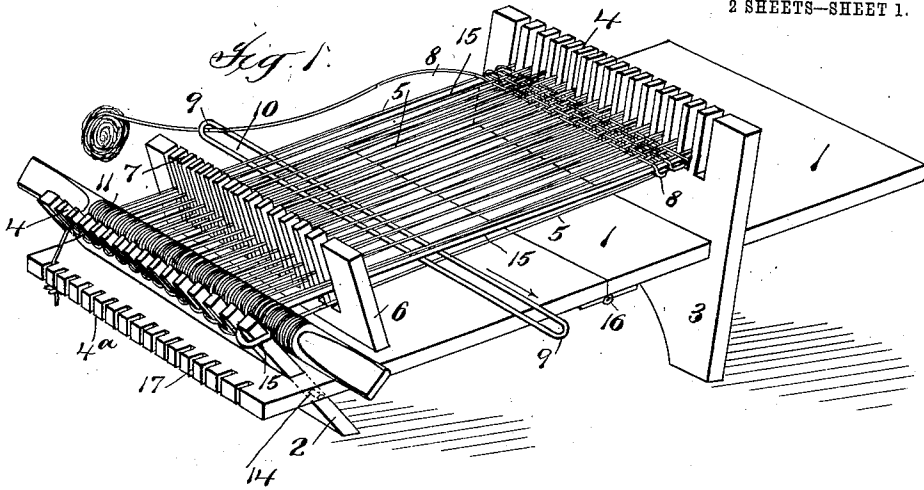

Attest:  
*J. H. Brown*  
*T. F. Howe*

Inventor:  
 M. P. C. Hooper  
 by *Philip Davenport Rice*  
*Hemingway*  
 Attys

No. 829,474.

PATENTED AUG. 28, 1906.

M. P. C. HOOPER.  
LOOM.

APPLICATION FILED AUG. 20, 1902.

2 SHEETS—SHEET 2.

Fig. 5.

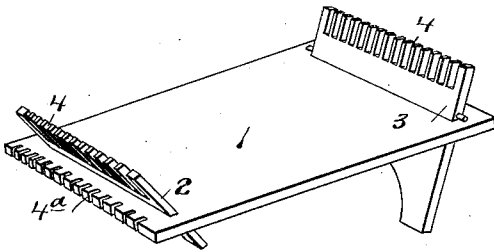

Fig. 6.

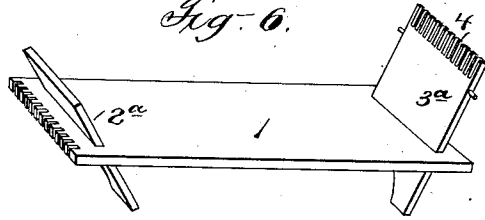

Fig. 7.

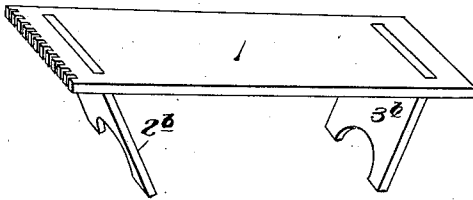

Fig. 8.

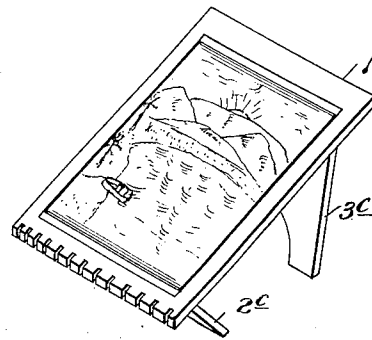

Fig. 9.

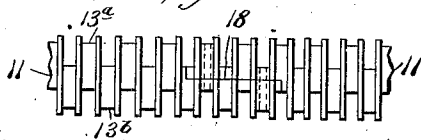
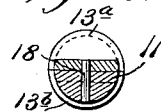

Fig. 10.



Attest:  
J. E. Groves  
T. P. Kehoe

Inventor:  
Mary P. C. Hooper  
By Philip Sawyer Rice & Kennel  
Attys

# UNITED STATES PATENT OFFICE.

MARY P. C. HOOPER, OF NEW YORK, N. Y.

## LOOM.

No. 829,474.

Specification of Letters Patent.

Patented Aug. 28, 1906.

Application filed August 20, 1902. Serial No. 120,314.

*To all whom it may concern:*

Be it known that I, MARY P. C. HOOPER, a citizen of the United States, residing at New York city, county of New York, and State of New York, have invented certain new and useful Improvements in Looms, fully described and represented in the following specification and the accompanying drawings, forming a part of the same.

This invention relates to improvements in hand-loom, and particularly to kindergartens-loom—that is to say, looms designed for use in instructing children in the art of weaving, although, as will hereinafter appear, the loom provided by the present invention may also be used with advantage by adults for the weaving of a variety of useful and ornamental articles

As a full understanding of the invention can best be had from a detailed description of an organization embodying the same, such description will now be given, reference being had to the accompanying drawings, in which—

Figure 1 is a perspective view of a loom embodying the present invention. Fig. 2 is a longitudinal section of the same. Fig. 3 is an end view of the same looking toward the right of Fig. 2. Fig. 4 is a detail of Fig. 2, illustrating the manner in which the material may be removed from the loom upon the completion of or when it is desired to interrupt a weaving operation. Fig. 5 is a perspective view illustrating a modification in the construction of the loom, the loom of this figure being designed particularly for kindergarten purposes and so formed as to be convertible by a child into different kinds of articles, as shown in Figs. 6, 7, and 8, Fig. 6 showing the loom of Fig. 5 converted into a toy bedstead, Fig. 7 showing it converted into a toy work-bench, and Fig. 8 showing it converted into a drawing-board. Fig. 9 is a modified form of heddle, which will be hereinafter referred to, and Fig. 10 is a cross-section of the same.

Referring to said drawings, 1 represents the body portion or frame of the loom, and 2 3 warp-holders, which are detachably connected to the body portion or frame 1 at opposite ends thereof. The frame 1 and warp-holders 2 3 are preferably of wood, because of cheapness in manufacture and lightness in weight. The front warp-holder 2 is connect-

ed to the body portion or frame 1 by means of a transverse slot formed in the latter, into which such warp-holder is introduced, while the warp-holder 3 is connected to the body portion or frame 1 by means of a transverse slot cut in such warp-holder and adapted for the entrance of the body portion or frame 1. The transverse slot in the body portion or frame 1 for receiving the front warp-holder 2 and the transverse slot in the rear warp-holder 3 for receiving the body portion or frame 1 are inclined in opposite directions, as shown, so that when such warp-holders 2 3 are connected to the body portion 1 they will be inclined in opposite directions, as best illustrated in Fig. 2, so as to properly hold the warp-threads and prevent them from slipping off the warp-holders. The warp-holders 2 3 are of different heights, as will be observed, (the front holder 2 being shorter,) so that the loom will in use occupy an inclined position which is very convenient. The warp-holders 2 3 are provided with a plurality of saw cuts or slits, forming warp-holding pins 4, around which the warp-threads 5 are passed, as illustrated in Figs. 1 to 4. The warp-holders 2 3 are not only detachably connected to the body portion or frame 1, but are relatively adjustable lengthwise of said body portion or frame, so as to vary the length of the warp, the warp-holder 3 by reason of the slot formed therein and through which it is connected to the body portion or frame 1 being movable bodily toward the warp-holder 2. The slot in holder 3, while permitting such bodily movement for adjustment of the warp-holder 3 will by reason of its incline prevent displacement of the holder under the pull of the warp-threads extending between it and the warp-holder 2. The loom of the present invention is also provided with a lay 6, consisting of a strip, preferably of wood, provided with vertical saw cuts or slits, forming teeth or pins 7 equal in number and extent of separation to the pins 4 of the warp-holders 2 3, such lay being movable longitudinally of the body portion or frame 1 into engagement with each weft-thread 8 as it is laid between the warp-threads, so as to force it toward the rear warp-holder 3 and into alinement and contact with the previously-laid weft-thread. The loom is also provided with an oblong shuttle 9, preferably of wire, and provided with a slot 10 for receiving the weft-thread

and carrying it through the warp, this shuttle being moved by the user back and forth between the sheds of the warp as the latter are formed by the heddle, which will now be described.

The heddle above referred to for forming the sheds in the warp consists of a cylindrical bar 11, of wood, which in use rests upon body portion or frame 1 between the lay 6 and the rear warp-holder 2 and in proximity to the latter, as shown, and has formed in its surface a series of annular grooves spaced to correspond to the spaces between the warp-threads. Each warp-thread passes around a pin 4 on the warp-holders 2 3, so that in the space between two pins of such warp-holders there are two warp-threads. The grooves in the heddle, therefore, are set or cut close together, so that two such grooves will come opposite each space or slot between the pins 4, so as to receive and separate the two threads passing through such slot or space. The two threads in each slot are designed to be raised and lowered successively to form the shed—that is to say, when one of these two threads is up the other is down, and vice versa. To provide for this movement of the warp-threads, the grooves in the heddle are formed in a peculiar manner, each groove having a high part 13<sup>a</sup> and a diametrically opposite low part 13<sup>b</sup>, with the high part of each groove in line with the low part of the next groove. From this it results that as the heddle is rotated each groove will successively raise and lower the warp-thread therein, and the several grooves thus raise each alternate warp-thread and lower the others, and vice versa, thus forming the shed for the passage of the shuttle 9. In other words, when the heddle-bar is in the position shown in Figs. 1 to 4, one set of warp-threads—that is, alternate warp-threads—will be raised by the high parts 13<sup>a</sup> of the grooves and the other threads lowered (falling into the low parts 13<sup>b</sup> of the grooves) so as to form one shed, between which the shuttle 9 is moved by the user, as illustrated in Figs. 1 and 2, and when the heddle-bar is given a half-turn by the user a new shed is formed, the previously-raised warp-threads being depressed and the previously-depressed threads raised by the heddle-bar.

It will be understood that each weft-thread 8 after it is drawn through the shed by the shuttle 9 will, as before stated, be moved rearwardly toward the warp-holder 3 and into contact and alinement with the previously-laid warp-thread by the lay 6, which is moved by the user longitudinally of the body portion or frame 1 of the loom toward warp-holder 3 and then returned to warp-holder 2 before the next weft-thread is passed between the warp-threads.

When it is desired to remove a piece of material woven upon the loom, all that need be

done is to press the warp-holder 2 downwardly, as illustrated in Fig. 4, and disengage the warp-threads from the pins 4 thereof, when the opposite ends of the material or warp-threads may be slipped off the pins 4 of the warp-holder 3. The warp-holder 2 is preferably provided with pins 14, which engage the under side of the body portion or frame 1 so as to limit the upward movement of the warp-holder. The loom of the present invention is also provided with side guides 15, around which the weft-threads are passed during the weaving operation, these side guides consisting of substantially rigid wire rods having loops at one end adapted to pass over the pins 4 of the warp-holder 2, the opposite end of the rod resting between two pins 4 of the warp-holder 3. These rods are removable from the loom and when in position thereon rest in two of the grooves at opposite ends of the heddle-bar 11, the rods being so positioned upon the heddle-bar as to be alternately raised and lowered as the sheds are formed by such heddle-bar, one of the rods being raised and the other lowered as each shed is formed, as illustrated in Fig. 1, and vice versa, so that the shuttle 9 as it is moved between the warp-threads will pass over and under one rod 15 and then under and over the other, and upon its return movement pass over and under the latter rod and under and over the other. These rods 15 are preferably curved or bent at their front ends so as to conform to some extent to the curvature of the heddle-bar 11, the object of so curving or bending the rods being to prevent such movement thereof upon the rotation of the heddle-bar as might result in disengaging them from the pins 4 of the warp-holder 2. If desired, rubber bands 16 may be used for holding the rods 15 against upward movement out of engagement with the pins 4 of the holders 2 3, as shown in Fig. 1; but such bands will only be necessary at the beginning of a weaving operation, as the weft-threads thereafter may be relied upon to hold the rods in place. Upon the completion of a weaving operation the rods 15 are removed from the material woven simply by slipping them lengthwise out of engagement, with the weft-threads passing around them. This may be done while the material woven is still on the loom or after the material woven is removed from the loom.

It will be observed that the several parts of the loom thus far described are detachable from the body portion or frame 1, so that they may be conveniently packed away for storage or shipment. Preferably, also, the body portion or frame 1 is hinged, as at 16, so that it may be folded up into small compass.

The body portion or frame 1 is preferably provided with saw cuts or slits 17 at one of its ends, the purpose of which is to receive and hold the knotted end of a warp-thread

as the latter is passed around the pins 4 of the warp-holders 2 3 preparatory to weaving and also to provide for the weaving of a piece of material having a greater length than that of the loom. When it is desired to weave such a greater length of material, all that is necessary to be done is to pass the warp-threads around the teeth or pins 4<sup>a</sup>, formed by the saw cuts or slits 17 in the end of the body portion or frame 1, and leave projecting downwardly from such body portion or frame 1 the greater length of warp-thread which it is desired to weave. Upon the completion of the weaving of the warp-threads first placed in position on the warp-holders 2 3 the woven material is removed from the warp-holders and shifted longitudinally of the body portion or frame 1, the woven portion being then slipped down over the pins 4 of the warp-holder 3 (with the last weft-thread thereof on the rear side of said holder) and the unwoven warp-threads, previously held in slits 17, moved through the slits between pins 4 of warp-holder 2 and properly secured in position therein. The warp-holder 3, as before stated, is adjustable; so that it may be moved to or from the warp-holder 2, if necessary, according to the length of the warp-threads so moved to position through the slits in warp-holder 2.

The body portion or frame 1 instead of being made in two sections hinged together, as in Figs. 1 and 2, may be made in a single piece, as in Fig. 5, and the warp-holders 2 3 instead of being connected thereto, as in Figs. 1 and 2—that is to say, with one fixed and the other having a sliding connection to body portion or frame 1—may be both connected to the body portion or frame 1 by oppositely-inclined slots formed in such body portion or frame.

The frame or body portion 1 may be utilized by children in making up toys or useful articles of various kinds. For example, it may be the use of the front warp-holder 2<sup>a</sup> and another support or headboard 3<sup>a</sup> be converted into a miniature bedstead, as shown in Fig. 6, or by the use of suitable supports 2<sup>b</sup> 3<sup>b</sup> be converted into a miniature work-bench, as shown in Fig. 7, or by the use of suitable supports 2<sup>c</sup> 3<sup>c</sup> into an inclined drawing-board, as shown in Fig. 8. This feature of convertibility is of quite a little importance, as with my device children may be taught not only the art of weaving, but the way in which various useful articles are manufactured or put together.

Referring now to Figs. 9 and 10, the modified form of heddle-bar there shown will be described. The heddle-bar here shown is precisely the same as that of Figs. 1 to 4, except that it is made in two sections which interlock at 18, the purpose of this construction being to adapt the heddle-bar for use on a narrow piece of material or narrow loom

(when one section only will be used) or a wider piece of material or a wider loom (when the two sections will be put together and used.

What I claim is—

1. A portable hand-loom comprising warp-holding means and a pair of weft-holders of substantially rigid material movable in opposite directions with the warp-threads, as each shed is formed, and adapted to be withdrawn from the material woven, substantially as described.

2. A portable hand-loom comprising warp-holding means and a pair of relatively adjustable weft-holders of substantially rigid material movable in opposite directions with the warp-threads, as each shed is formed, and adapted to be withdrawn from the material woven, substantially as described.

3. A portable hand-loom comprising warp-holding means, a toothed lay, and a pair of weft-holders of substantially rigid material adapted to be withdrawn from the material woven, substantially as described.

4. A portable hand-loom comprising warp-holding means, a heddle, and a pair of weft-holders of substantially rigid material adapted to be withdrawn from the material woven, substantially as described.

5. A portable hand-loom comprising warp-holding means, a toothed lay, a heddle, and a pair of weft-holders of substantially rigid material adapted to be withdrawn from the material woven, substantially as described.

6. A hand-loom comprising warp-holding means, a heddle, and weft-holders of substantially rigid material movable by the heddle in opposite directions with the warp-threads, as each shed is formed, and adapted to be withdrawn from the material woven, substantially as described.

7. A hand-loom comprising warp-holding means, a toothed lay, a heddle, and weft-holders of substantially rigid material movable by the heddle in opposite directions with the warp-threads, as each shed is formed, and adapted to be withdrawn from the material woven, substantially as described.

8. A shuttle for hand-looms consisting of a member having an elongated slot or opening of substantially the length of said member for the weft-thread and adapted to enter the warp-threads at either end, whereby the shuttle may be passed back and forth without reversal, substantially as described.

9. A loom of the class described comprising a body portion or frame having a transverse slot, a warp-holder detachably secured in said slot, and a second warp-holder adjustably secured to said body portion or frame, substantially as described.

10. A loom of the class described comprising a body portion or frame having a transverse slot, a warp-holder detachably secured in said slot, and a second warp-holder adjustably secured to said body portion or

frame by a slot in the warp-holder through which the body portion or frame passes, substantially as described.

11. A loom of the class described comprising a body portion or frame and suitable detachable warp-holders also serving as supports for the body portion or frame, substantially as described.

12. A loom of the class described comprising a body portion or frame and suitable detachable warp-holders also serving as supports for the body portion or frame, the supporting portions of the warp-holders being of different heights, whereby the loom is supported in an inclined position, substantially as described.

13. A loom of the class described comprising a body portion or frame, a pair of suitable detachable warp-holders, and means outside one of the warp-holders adapted to engage and hold the warp-threads when of greater length than the distance between the warp-holders, substantially as described.

14. A loom of the class described comprising a body portion or frame, a pair of suitable detachable warp-holders, and means outside each of the warp-holders adapted to engage and hold the warp-threads when of greater

length than the distance between the warp-holders, substantially as described. 30

15. A loom of the class described comprising a body portion or frame, a pair of suitable detachable warp-holders, and means outside one of the warp-holders adapted to engage and hold the warp-threads when of greater length than the distance between the warp-holders, such means consisting of slits in the body portion or frame, substantially as described. 35

16. A loom of the class described comprising a body portion or frame, a pair of suitable detachable warp-holders, and means outside each of the warp-holders adapted to engage and hold the warp-threads when of greater length than the distance between the warp-holders, such means consisting of slits in the body portion or frame, substantially as described. 40 45

In testimony whereof I have hereunto set my hand in the presence of two subscribing witnesses. 50

MARY P. C. HOOPER.

Witnesses:

J. A. GRAVES,  
T. F. KEHOE.