



- (51) **International Patent Classification:**  
*E05B 73/00* (2006.01)    *E05B 67/08* (2006.01)
- (21) **International Application Number:**  
PCT/US2017/018698
- (22) **International Filing Date:**  
21 February 2017 (21.02.2017)
- (25) **Filing Language:** English
- (26) **Publication Language:** English
- (30) **Priority Data:**  
62/299,848    25 February 2016 (25.02.2016)    US
- (71) **Applicant:** ACCO BRANDS CORPORATION  
[US/US]; Four Corporate Drive, Lake Zurich, IL 60047-8997 (US).
- (72) **Inventors:** KAO, James; 4450 Eggers Drive, Fremont, CA 94536 (US). KLINKMAN, Alex, J.; 2008 Hill Ave, Apt. 4, Hayward, CA 94542 (US). TERESI, Joseph, A.; 1500 Fashion Island Blvd, San Mateo, CA 94404 (US). TSE, Wilson; 5146 Mckee Street, Burnaby, British Columbia, V5J2T4 (CA). OTSUKA, Mike; 486 E Mckinley Ave, Sunnyvale, CA 94086 (US). DE MEULENAERE, William; 6046 Peppertree Court, Newark, CA 94560 (US).
- (74) **Agent:** TRAUTSCHOLD, David, J.; Michael Best & Friedrich LLP, 100 East Wisconsin Avenue, Suite 3300, Milwaukee, WI 53202 (US).

- (81) **Designated States** (unless otherwise indicated, for every kind of national protection available): AE, AG, AL, AM, AO, AT, AU, AZ, BA, BB, BG, BH, BN, BR, BW, BY, BZ, CA, CH, CL, CN, CO, CR, CU, CZ, DE, DJ, DK, DM, DO, DZ, EC, EE, EG, ES, FI, GB, GD, GE, GH, GM, GT, HN, HR, HU, ID, IL, IN, IR, IS, JP, KE, KG, KH, KN, KP, KR, KW, KZ, LA, LC, LK, LR, LS, LU, LY, MA, MD, ME, MG, MK, MN, MW, MX, MY, MZ, NA, NG, NI, NO, NZ, OM, PA, PE, PG, PH, PL, PT, QA, RO, RS, RU, RW, SA, SC, SD, SE, SG, SK, SL, SM, ST, SV, SY, TH, TJ, TM, TN, TR, TT, TZ, UA, UG, US, UZ, VC, VN, ZA, ZM, ZW.
- (84) **Designated States** (unless otherwise indicated, for every kind of regional protection available): ARIPO (BW, GH, GM, KE, LR, LS, MW, MZ, NA, RW, SD, SL, ST, SZ, TZ, UG, ZM, ZW), Eurasian (AM, AZ, BY, KG, KZ, RU, TJ, TM), European (AL, AT, BE, BG, CH, CY, CZ, DE, DK, EE, ES, FI, FR, GB, GR, HR, HU, IE, IS, IT, LT, LU, LV, MC, MK, MT, NL, NO, PL, PT, RO, RS, SE, SI, SK, SM, TR), OAPI (BF, BJ, CF, CG, CI, CM, GA, GN, GQ, GW, KM, ML, MR, NE, SN, TD, TG).

**Published:**  
— with international search report (Art. 21(3))

(54) **Title:** SECURITY APPARATUS FOR PORTABLE ELECTRONIC DEVICE

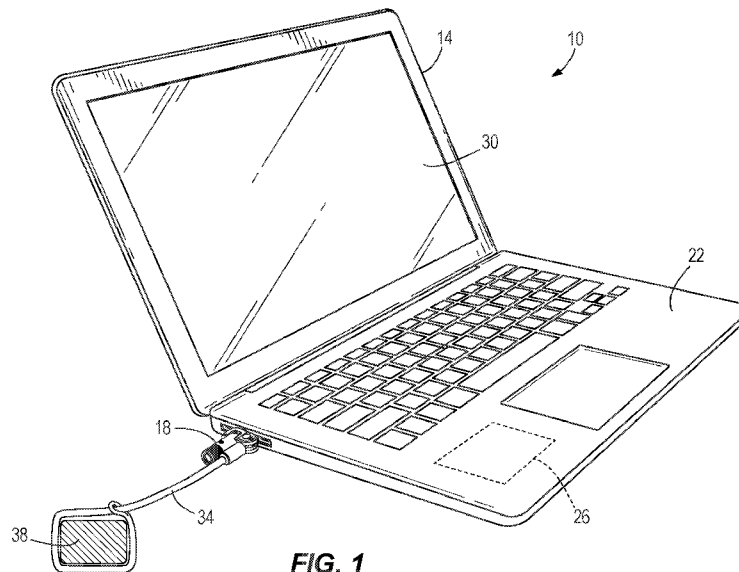

**FIG. 1**

(57) **Abstract:** A security apparatus for a portable electronic device having an aperture includes a lock mechanism having a lock cylinder and a cam member. The lock cylinder is configured to be rotated by a key. The cam member is coupled to the lock cylinder for rotation with the lock cylinder. The cam member has a slot. The security apparatus also includes an engagement mechanism having a first finger, a second finger, and a plunger. The first finger and the second finger are configured to be inserted into the aperture of the portable electronic device. The plunger is positioned between the first finger and the second finger and has a cam follower positioned within the slot of the cam member. As the cam member is rotated by the lock cylinder, the plunger pushes the first finger and the second finger apart from each other to engage the portable electronic device.

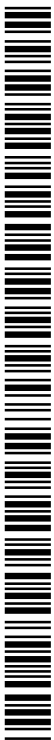

## SECURITY APPARATUS FOR PORTABLE ELECTRONIC DEVICE

### CROSS-REFERENCE TO RELATED APPLICATIONS

**[0001]** This application claims priority to U.S. Provisional Patent Application No. 62/299,848, filed February 25, 2016, the entire contents of which are incorporated by reference herein.

### FIELD OF THE INVENTION

**[0002]** The present invention relates to security apparatuses for portable electronic devices, such as laptop computers, tablet computers, smartphones, and other mobile devices.

### SUMMARY

**[0003]** In one embodiment, the invention provides a security apparatus for a portable electronic device. The portable electronic device has an aperture. The security apparatus includes a lock mechanism having a lock cylinder and a cam member. The lock cylinder is configured to be rotated by a key. The cam member is coupled to the lock cylinder for rotation with the lock cylinder. The cam member has a slot. The security apparatus also includes an engagement mechanism having a first finger, a second finger, and a plunger. The first finger and the second finger are configured to be inserted into the aperture of the portable electronic device. The plunger is positioned between the first finger and the second finger and has a cam follower positioned within the slot of the cam member. As the cam member is rotated by the lock cylinder, the plunger pushes the first finger and the second finger apart from each other to engage the portable electronic device.

**[0004]** In another embodiment, the invention provides a system including a portable electronic device and the security apparatus. The portable electronic device has a housing, a processor positioned within the housing, a screen supported by the housing, and an aperture formed in the housing.

**[0005]** In yet another embodiment, the invention provides a security apparatus for a portable electronic device. The portable electronic device has an aperture. The security apparatus includes a lock mechanism having a lock cylinder and a cam member. The lock cylinder is

configured to be rotated by a key. The cam member is coupled to the lock cylinder for rotation with the lock cylinder. The cam member has a slot. The security apparatus also includes an engagement mechanism having a first finger, a second finger, and a plunger. The first finger and the second finger are configured to be inserted into the aperture of the portable electronic device. The plunger has a cam follower positioned within the slot of the cam member so that rotation of the cam member moves the plunger relative to the first and second fingers. The engagement mechanism is movable between a first position, in which the plunger is retracted and the first and second fingers disengage the portable electronic device, and a second position, in which the plunger is extended and the first and second fingers engage the portable electronic device.

**[0006]** Other aspects of the invention will become apparent by consideration of the detailed description and accompanying drawings.

#### BRIEF DESCRIPTION OF THE DRAWINGS

**[0007]** Fig. 1 illustrates a system including a portable electronic device and a security apparatus embodying the present invention.

**[0008]** Fig. 2 is a perspective view of a portion of the portable electronic device, the portable electronic device having an aperture.

**[0009]** Fig. 3 is a front view of the portion of the portable electronic device shown in Fig. 2.

**[0010]** Fig. 4 is a cross-sectional view of the portion of the portable electronic device taken along section line 4-4 of Fig. 3.

**[0011]** Fig. 5 is a cross-sectional view of the portion of the portable electronic device taken along section line 5-5 of Fig. 3.

**[0012]** Fig. 6 is a perspective view of the security apparatus shown in Fig. 1.

**[0013]** Fig. 7 is a top view of a portion of the security apparatus of Fig. 6 while in an unlocked position.

**[0014]** Fig. 8 is a top view of the portion of the security apparatus of Fig. 6 while in a locked position.

**[0015]** Fig. 9 is a top view of the security apparatus of Fig. 6 with a cylindrical body removed.

**[0016]** Fig. 10 is a side view of the security apparatus of Fig. 6 with the cylindrical body removed.

**[0017]** Fig. 11 is an exploded perspective view of the security apparatus of Fig. 6.

**[0018]** Fig. 12 is a perspective view of another security apparatus embodying the present invention.

**[0019]** Fig. 13 is a top view of a portion of the security apparatus of Fig. 12 while in an unlocked position.

**[0020]** Fig. 14 is a top view of the portion of the security apparatus of Fig. 12 while in a locked position.

**[0021]** Fig. 15 is a cross-sectional view of the security apparatus taken along section line 15-15 of Fig. 12.

**[0022]** Fig. 16 is a cross-sectional view of the security apparatus taken along section line 16-16 of Fig. 12.

**[0023]** Fig. 17 is an exploded perspective view of the security apparatus of Fig. 12.

**[0024]** Fig. 18 is a perspective view of yet another security apparatus embodying the present invention.

**[0025]** Fig. 19 is a top view of a portion of the security apparatus of Fig. 18 while in an unlocked position.

**[0026]** Fig. 20 is a top view of the portion of the security apparatus of Fig. 18 while in a locked position.

[0027] Fig. 21 is a cross-sectional view of the security apparatus taken along section line 21-21 of Fig. 18.

[0028] Fig. 22 is a cross-sectional view of the security apparatus taken along section line 22-22 of Fig. 18.

[0029] Fig. 23 is an exploded perspective view of the security apparatus of Fig. 18.

#### DETAILED DESCRIPTION

[0030] Before any embodiments of the invention are explained in detail, it is to be understood that the invention is not limited in its application to the details of construction and the arrangement of components set forth in the following description or illustrated in the following drawings. The invention is capable of other embodiments and of being practiced or of being carried out in various ways.

[0031] Fig. 1 illustrates a system 10 including a portable electronic device 14 and a security apparatus 18. In the illustrated embodiment, the portable electronic device 14 is a laptop computer, but may alternatively be a tablet computer, a smartphone, an eReader, an MP3 player, and the like. The illustrated portable electronic device 14 includes a housing 22, a processor 26 positioned within the housing 22, and a screen 30 supported by the housing 22. In some embodiments, the screen 30 may be a touchscreen. In other embodiments, such as the illustrated embodiment, the portable electronic device 14 may also or alternatively include other input mechanisms, such as a keyboard, keypad, or touchpad. The security apparatus 18 is connected to the portable electronic device 14 and includes a cable 34 to secure the portable electronic device 14 to an immovable object 38, such as a table, a chair, a bracket, a wall, and the like.

[0032] As shown in Figs. 2-5, the portable electronic device 14 has an aperture 42, or slot, formed in the housing 22. The illustrated aperture 42 is generally smaller than existing security slots in portable electronic devices, and is specifically designed for thinner devices with smaller housings. The aperture 42 is defined by an upper wall 43, a lower wall 44, two opposing sidewalls 45, and a rear wall 46. As shown in Fig. 5, the upper and lower walls 43, 44 are generally parallel to each other. The upper wall 43 has a first section 43A near the outer surface

of the housing 22, and a second section 43B inward of the first section 43A. Similarly, the lower wall 44 has a first section 44A near the outer surface of the housing 22, and a second section 44B inward of the first section 44A. The second sections 43B, 44B are slightly offset relative to the first sections 43A, 44A. As shown in Fig. 4, the sidewalls 45 are generally parallel to each other and perpendicular to the upper and lower walls 43, 44. Each sidewall 45 has a first section 45A near the outer surface of the housing 22, and a second section 45B inward of the first section 45A. The second sections 45B are outwardly offset from the first sections 45A such that a shoulder or ledge 45C is formed between the first and second sections 45A, 45B. The rear wall 46 extends between and connects the upper wall 43, the lower wall 44, and the sidewalls 45. The rear wall 46 also closes the back of the aperture 42 to separate the aperture 42 from the internal components of the device 14.

**[0033]** By way of example, the aperture 42 can have an external width  $W_1$  (measured between the first sections 44A of the sidewalls 44) of about 6 mm. The aperture 42 can also have an external height  $H_1$  (measured between the upper and lower walls 43A, 43B) of about 2.5 mm. In addition, the aperture 42 can have an internal width  $W_2$  (measured between the second sections 44B of the sidewalls 44) of at least 9 mm. Further, the aperture 42 can have an internal depth  $D$  (measured from the outer surface of the housing 22 to the rear wall 46) of at least 7 mm. The internal depth  $D$  is defined by a wall thickness  $T$  (i.e., the length of the first sections 43A, 44A, 45A) and a clearance depth  $C$  (i.e., the length of the second sections 43B, 44B, 45B). In some embodiments, the wall thickness  $T$  may be  $3.5 \text{ mm} \pm 0.25 \text{ mm}$ . Additionally, the clearance depth  $C$  may be at least 3.5 mm. The aperture 42 can also have an internal height  $H_2$  (measured between the second sections 43B, 44B of the upper and lower walls 43, 44) of at least 2.65 mm. In other embodiments, the aperture 42 can have other dimensions. The aperture 42 is configured to receive an engagement mechanism of a security apparatus, such as one of the security apparatuses described below.

**[0034]** Figs. 6-11 illustrate one example of the security apparatus 18. The security apparatus 18 includes a cylindrical body 48, a lock mechanism 50, and an engagement mechanism 54. The cylindrical body 48 is made of a relatively hard material, such as metal, and houses other components of the security apparatus 18. In other embodiments, the cylindrical body 48 can

have other, non-cylindrical shapes. The illustrated body 48 includes a knurled section 58 to facilitate grasping and holding the security apparatus 18.

**[0035]** As shown in Figs. 9-11, the illustrated lock mechanism 50 includes a lock cylinder 62 and a cam member 66. The lock cylinder 62 and the cam member 66 are positioned within the cylindrical body 48. The lock cylinder 62 is arranged in line with the engagement mechanism 54 along a longitudinal axis 70 of the security apparatus 18. As such, the lock cylinder 62 also defines the longitudinal axis 70 and is actuatable (e.g., rotatable) about the axis 70. In the illustrated embodiment, the lock cylinder 62 is rotatable by, for example, a key 74 (Fig. 6). In other embodiments, the lock mechanism 50 may include a combination-style lock.

**[0036]** The cam member 66 is coupled to the lock cylinder 62 for rotation with the lock cylinder 62 about the longitudinal axis 70. In particular, the cam member 66 includes a stem 78 that extends into the lock cylinder 62, and a cam body 82 positioned forward of the lock cylinder 62 and engaging the engagement mechanism 54. In the illustrated embodiment, the cam member 66 has slots 86 formed in the cam body 82. The illustrated slots 86 are arcuate slots that curve around the circumference of the cam body 82. The slots 86 are also obliquely angled relative to the longitudinal axis 70 so that the slots 86 helically wind around cam body 82. Each slot 86 includes a first end 90 adjacent the engagement mechanism 54, a second end 94 adjacent the lock cylinder 62, and a detent 98 formed at the first end 90. In other embodiments, the cam member 66 may include fewer or more slots 86 formed in the cam body 82.

**[0037]** As shown in Figs. 7-8 and 11, the illustrated engagement mechanism 54 includes two fingers 102 and a plunger 106. The fingers 102 are movable (e.g., pivotable) between an unlocked or retracted position (Fig. 7) and a locked or expanded position (Fig. 8). When the fingers 102 are in the unlocked position, the engagement mechanism 54 is insertable into and removable from the aperture 42 in the portable electronic device 14 (Figs. 1-5). When the fingers 102 are in the locked position, the engagement mechanism 54 engages the housing 22 of the portable electronic device 14 to secure the security apparatus 18 to the device 14. Each finger 102 includes an enlarged distal end 110 and a relatively narrower stem 114. The enlarged distal ends 110 facilitate engaging (e.g., contacting or “grabbing”) the housing 22 of the portable electronic device 14 so that the security apparatus 18 cannot be pulled out of the aperture 42.

Particularly, the enlarged distal ends 110 engage the ledges 45C of the sidewalls 45 (Fig. 4) formed by the aperture 42. The relatively narrower stems 114 create a recessed area 118 between the fingers 102 for receiving the plunger 106. Each finger 102 also includes a boss 116 at an end of the stem 114 opposite from the enlarged distal end 110. The bosses 116 define spaced apart pivot axes for the fingers 102.

**[0038]** The plunger 106 is positioned between the fingers 102 to selectively move the fingers 102 from the unlocked position to the locked position. The plunger 106 includes cam followers 122 that are received in the slots 86 of the cam member 66. In the illustrated embodiment, the cam followers 122 are pins. In other embodiments, the plunger 106 may include fewer or more cam followers 122, depending on the number of slots 86 in the cam member 66. The plunger 106 is movable (e.g., slidable) along the longitudinal axis 70 to selectively actuate the fingers 102. The security apparatus 18 also includes an end cap 126 coupled to the cylindrical body 48 opposite from the lock cylinder 62 to help retain the fingers 102 and the plunger 106 in connection with the lock mechanism 50 and the body 48.

**[0039]** Referring to Fig. 7, in an initial position (i.e., when the fingers 102 are in the unlocked position), the cam followers 122 of the plunger 106 are positioned at the second ends 94 of the slots 86 in the cam member 66. In this position, a distal end section of the plunger 106 is received within the recessed area 118 formed between the fingers 102. The fingers 102 are moved (e.g., pivoted) toward each other so that the enlarged distal ends 110 contact each other. In some embodiments, the engagement mechanism 54 may include a spring element, such as an elastomeric ring 130 shown in Fig. 11, to help move the fingers 102 toward each other. In this position, the engagement mechanism 54 can be inserted into or removed from the aperture 42 of the portable electronic device 14.

**[0040]** Referring to Figs. 8-10, when the cam member 66 is rotated (e.g., by rotating the lock cylinder 62 with the key 74), the cam followers 122 follow the slots 86 of the cam member 66 to move the plunger 106 axially outward. As the plunger 106 slides axially outward (i.e., in the direction of arrow A), the plunger 106 pushes the fingers 102 apart from each other (i.e., in the direction of arrows B). More particularly, the fingers 102 are pushed and expanded radially outward to engage the housing 22 of the portable electronic device 14 (if the engagement

mechanism 54 is inserted into the aperture 42 of the portable electronic device 14). The cam member 66 is rotated about 90 degrees until the cam followers 122 reach the first ends 90 of the slots 86. As shown in Fig. 10, each cam follower 122 is received in the corresponding detent 98 at the first end 90 of the slot 86 when in the locked position. In this position, the engagement mechanism 54 is inhibited from being removed from (e.g., pulled out of) the aperture 42 of the device 14. In addition, the detents 98 provide recesses that inhibit the cam followers 122 from being bumped out of the first ends 90 of the slots 86 and moved back toward the second ends 94 of the slots 86 without purposefully rotating the cam member 66 (e.g., with the key 74).

**[0041]** As shown in Figs. 6 and 11, the security apparatus 18 also includes a cable mount 134 supported by the cylindrical body 48. The illustrated cable mount 134 is positioned generally between the lock mechanism 50 and the engagement mechanism 54. The cable mount 134 includes a boss 138 extending radially from the cylindrical body 48. The cable mount 134 is configured to securely receive an end of the flexible cable 34, which can be wrapped around an immovable object 38 (Fig. 1) to secure the security apparatus 18 (and, thereby, the portable electronic device 14) to the immovable object 38.

**[0042]** Figs. 12-17 illustrate another example of a security apparatus 218. The security apparatus 218 is similar to the security apparatus 18 discussed above with reference to Figs. 6-11. Differences between the two security apparatuses 18, 218 are described below.

**[0043]** The security apparatus 218 includes a body 222, a lock mechanism 226, and an engagement mechanism 230. The body 222 has a first body portion 234 that generally houses the lock mechanism 226, and a second body portion 238 that generally houses the engagement mechanism 230. In the illustrated embodiment, the body portions 234, 238 are arranged generally perpendicular to each other so that the first body portion 234 extends upward (e.g., away from a table or other surface supporting the portable electronic device 14) relative to the second body portion 238.

**[0044]** As shown in Figs. 15-17, the illustrated lock mechanism 226 includes a lock cylinder 242 and a cam member 246. The lock cylinder 242 is arranged at 90 degrees relative to a longitudinal axis 250 of the engagement mechanism 230 and the second body portion 238. The

lock cylinder 242 is rotatable by, for example, a key 254 (Fig. 12). In other embodiments, the lock mechanism 226 may include a combination-style lock.

**[0045]** The cam member 246 is coupled to the lock cylinder 242 for rotation with the lock cylinder 242. In particular, the cam member 246 includes a stem 258 that extends into the lock cylinder 242, and an enlarged cam 262 coupled to a distal end of the stem 258, opposite from the lock cylinder 242. The enlarged cam 262 engages the engagement mechanism 230 to actuate the engagement mechanism 230.

**[0046]** With continued reference to Figs. 13-17, the illustrated engagement mechanism 230 includes two fingers 266 and plunger 270. The fingers 266 are movable (e.g., pivotable) between an unlocked or retracted position (Fig. 13) and a locked or expanded position (Fig. 14). When the fingers 266 are in the unlocked position, the engagement mechanism 230 is insertable into and removable from the aperture 42 in the portable electronic device 14 (Figs. 1-5). When the fingers 266 are in the locked position, the engagement mechanism 230 engages the housing 22 of the portable electronic device 14 to secure the security apparatus 218 to the device 14.

**[0047]** The illustrated plunger 270 is partially received in a guide block 272. The guide block 272 helps restrict movement of the plunger 270 to linear sliding movement in the direction of arrow C. The guide block 272 also forms part of a bottom section of the body 222. In the illustrated embodiment, the guide block 272 is a separate piece from the rest of the body 222 to facilitate assembling the security apparatus 218.

**[0048]** In the illustrated embodiment, the fingers 266 are moved between the unlocked and locked positions by rotating the cam member 246 with the lock cylinder 242. More particularly, the plunger 270 includes a recess 274, or cam follower, that receives the enlarged cam 262 of the cam member 246. When the cam member 246 is rotated (e.g., by rotating the lock cylinder 242 with the key 254), the enlarged cam 262 pushes the plunger 270 axially outward or inward, depending on which direction the cam member 246 is rotated. As the plunger 270 slides axially outward (i.e., in the direction of arrow C), the fingers 266 are pushed apart and expanded radially outward (i.e., in the direction of arrows D). As the plunger 270 slides axially inward, the fingers 266 can move toward each other. In the illustrated embodiment, the distal ends of the fingers 266 include corresponding cutouts 278 such that the fingers 266 can slightly overlap when in the

unlocked position (as shown in Fig. 13). In some embodiments, the engagement mechanism 230 may include a spring element, such as an elastomeric ring 280 shown in Fig. 17, to help move the fingers 266 toward each other.

**[0049]** As shown in Figs. 12 and 17, the security apparatus 218 also includes a cable mount 282 supported at an end of the body 222 opposite from the engagement mechanism 230. The cable mount 282 is configured to securely receive an end of a flexible cable 286. The flexible cable 286 can be, for example, wrapped around an immovable object 38 (Fig. 1) to secure the security apparatus 218 to the immovable object 38. The illustrated cable mount 282 also includes a joint 290 that allows the cable 286 to be pivoted relative to the body 222.

**[0050]** Figs. 18-23 illustrate another example of a security apparatus 318. The security apparatus 318 is similar to the security apparatus 18 discussed above with reference to Figs. 6-11. Differences between the two security apparatuses 18, 318 are described below.

**[0051]** The security apparatus 318 includes a body 322, a lock mechanism 326, and an engagement mechanism 330. The body 322 has a first body portion 334 that generally houses the lock mechanism 326, and a second body portion 338 that generally houses the engagement mechanism 330. The body portions 334, 338 are obliquely angled relative to each other. For example, in the illustrated embodiment, the first body portion 334 is angled about 45 degrees relative to the second body portion 338 such that the first body portion 334 extends upwardly and rearwardly from the second body portion 338.

**[0052]** As shown in Figs. 21-22, the illustrated lock mechanism 326 includes a lock cylinder 342 and a cam member 346. The lock cylinder 342 is arranged at 45 degrees relative to a longitudinal axis 350 of the engagement mechanism 330 and the second body portion 338. The lock cylinder 342 is rotatable by, for example, a key 354 (Fig. 18). In other embodiments, the lock mechanism 326 may include a combination-style lock.

**[0053]** The cam member 346 is coupled to the lock cylinder 342 for rotation with the lock cylinder 342. In particular, the cam member 346 includes a stem 358 that extends into the lock cylinder 342, and an enlarged cam 362 coupled to a distal end of the stem 358, opposite from the

lock cylinder 342. The illustrated enlarged cam 362 includes a cam surface 366 facing and contacting the engagement mechanism 330.

**[0054]** The illustrated engagement mechanism 330 includes two fingers 370 and a cam follower 374. The fingers 370 are movable (e.g., pivotable) between an unlocked or retracted position (Fig. 19) and a locked or expanded position (Fig. 20). When the fingers 370 are in the unlocked position, the engagement mechanism 330 is insertable into and removable from the aperture 42 in the portable electronic device 14 (Figs. 1-5). When the fingers 370 are in the locked position, the engagement mechanism 330 engages the housing 22 of the portable electronic device 14 to secure the security apparatus 318 to the device 14.

**[0055]** The cam follower 374 is positioned between the fingers 370 and the cam member 346. The illustrated cam follower 374 includes two wings 378, each of which engages one of the fingers 370. The wings 378 have ramped surfaces 382 that selectively press proximal ends 386 of the fingers 370 together, causing distal ends 390 of the fingers 370 to spread apart.

**[0056]** In the illustrated embodiment, the fingers 370 are moved between the unlocked and locked positions by rotating the cam member 346 with the lock cylinder 342. More particularly, the cam follower 374 abuts the cam surface 366 of the cam member 346. As the cam member 346 is rotated (e.g., by rotating the lock cylinder 342 with the key 354), the enlarged cam 362 is rotated to move the cam surface 366 relative to the cam follower 374. When a recessed portion of the cam surface 366 is aligned and in contact with the cam follower 374, the cam follower 374 moves (e.g., slides) away from the fingers 370 (to the right in Fig. 21). As the cam follower 374 moves away from the fingers 370, the wings 378 of the cam follower 374 allow the proximal ends 386 of the fingers 370 to spread apart so that the distal ends 390 of the fingers 370 move toward each other. When a protruding portion of the cam surface 366 is aligned and in contact with the cam follower 374, the cam member 346 pushes (e.g., slides) the cam follower 374 toward the fingers 370 (to the left in Fig. 21). As the cam follower 374 moves toward the fingers 370, the wings 378 of the cam follower 374 push the proximal ends 386 of the fingers 370 together so that the distal ends 390 of the fingers 370 are spread apart from each other (i.e., in the direction of arrows E).

**[0057]** As shown in Figs. 18 and 23, the security apparatus 318 also includes a cable mount 394 supported on an end of the body 322 opposite from the engagement mechanism 330. Only part of the cable mount 394 is shown in the figures, but the cable mount 394 may be constructed similar to the cable mount 282 shown in Figs. 12-17. The cable mount 394 is configured to securely receive a flexible cable (not shown, but similar to the cables 34, 286 described above). The flexible cable can be, for example, wrapped around an immovable object 38 (Fig. 1) to secure the security apparatus 318 to the immovable object 38.

**[0058]** The illustrated security apparatuses 18, 218, 318 provide relatively compact lock and engagement mechanisms that facilitate interfacing with thinner portable electronic devices. In particular, the security apparatuses 18, 218, 318 are designed to engage relatively smaller apertures in portable electronic devices, yet still provide at least the same strength of security as conventional laptop locks. Further, the security apparatuses 18, 218, 318 are physically compact so that a portable electronic device can lay flat on a surface (e.g., table or desk) without interference from the attached security apparatus 18, 218, 318.

**[0059]** Various features and advantages of the invention are set forth in the following claims.

## CLAIMS

What is claimed is:

1. A security apparatus for a portable electronic device, the portable electronic device having an aperture, the security apparatus comprising:
  - a lock mechanism including a lock cylinder and a cam member, the lock cylinder configured to be rotated by a key, the cam member coupled to the lock cylinder for rotation with the lock cylinder, the cam member having a slot; and
  - an engagement mechanism including a first finger, a second finger, and a plunger, the first finger and the second finger configured to be inserted into the aperture of the portable electronic device, the plunger positioned between the first finger and the second finger and having a cam follower positioned within the slot of the cam member,wherein as the cam member is rotated by the lock cylinder, the plunger pushes the first finger and the second finger apart from each other to engage the portable electronic device.
2. The security apparatus of claim 1, wherein the first finger and the second finger pivot apart from each other.
3. The security apparatus of claim 1, wherein the lock cylinder defines a longitudinal axis, and wherein the cam member is rotatable about the longitudinal axis.
4. The security apparatus of claim 3, wherein the plunger moves along the longitudinal axis as the cam member is rotated by the lock cylinder.
5. The security apparatus of claim 4, wherein the plunger moves from a retracted position relative to the first and second fingers to an extended position relative to the first and second fingers as the cam member is rotated.
6. The security apparatus of claim 3, wherein the slot of the cam member is obliquely angled relative to the longitudinal axis.

7. The security apparatus of claim 1, wherein the slot includes a first end, a second end, and a detent formed at the first end, and wherein the cam follower is received in the detent when the plunger pushes the first finger and the second finger apart from each other.

8. The security apparatus of claim 1, wherein the slot is a first slot and the cam follower is a first cam follower, wherein the cam member has a second slot spaced apart from the first slot, and wherein the plunger includes a second cam follower positioned within the second slot of the cam member.

9. The security apparatus of claim 1, further comprising:  
a cylindrical body, wherein the lock cylinder and the cam member are positioned within the cylindrical body; and  
a cable secured to the cylindrical body, wherein the cable is configured to engage an immovable object.

10. The security apparatus of claim 9, further comprising a cable mount supported by the cylindrical body and positioned between the lock mechanism and the engagement mechanism, wherein the cable mount includes a boss extending radially from the cylindrical body, and wherein an end of the cable is secured to the boss.

11. A system comprising:  
a portable electronic device having a housing, a processor positioned within the housing, a screen supported by the housing, and an aperture formed in the housing; and  
the security apparatus of claim 1.

12. A security apparatus for a portable electronic device, the portable electronic device having an aperture, the security apparatus comprising:

a lock mechanism including a lock cylinder and a cam member, the lock cylinder configured to be rotated by a key, the cam member coupled to the lock cylinder for rotation with the lock cylinder, the cam member having a slot; and

an engagement mechanism including a first finger, a second finger, and a plunger, the first finger and the second finger configured to be inserted into the aperture of the portable electronic device, the plunger having a cam follower positioned within the slot of the cam member so that rotation of the cam member moves the plunger relative to the first and second fingers, the engagement mechanism movable between a first position, in which the plunger is retracted and the first and second fingers disengage the portable electronic device, and a second position, in which the plunger is extended and the first and second fingers engage the portable electronic device.

13. The security apparatus of claim 12, wherein the first and second fingers move apart from each other when the engagement mechanism moves from the first position to the second position.

14. The security apparatus of claim 13, wherein the first and second fingers pivot apart from each other when the engagement mechanism moves from the first position to the second position.

15. The security apparatus of claim 12, wherein the lock cylinder defines a longitudinal axis, and wherein the cam member is rotatable about the longitudinal axis.

16. The security apparatus of claim 15, wherein the plunger moves along the longitudinal axis when the engagement mechanism moves between the first and second positions.

17. The security apparatus of claim 15, wherein the slot of the cam member is obliquely angled relative to the longitudinal axis.

18. The security apparatus of claim 12, wherein the slot includes a first end, a second end, and a detent formed at the first end, and wherein the cam follower is received in the detent when the engagement mechanism is in the second position.
19. The security apparatus of claim 12, further comprising:  
a cylindrical body, wherein the lock cylinder and the cam member are positioned within the cylindrical body; and  
a cable secured to the cylindrical body, wherein the cable is configured to engage an immovable object.
20. The security apparatus of claim 19, further comprising a cable mount supported by the cylindrical body and positioned between the lock mechanism and the engagement mechanism, wherein the cable mount includes a boss extending radially from the cylindrical body, and wherein an end of the cable is secured to the boss.

1/14

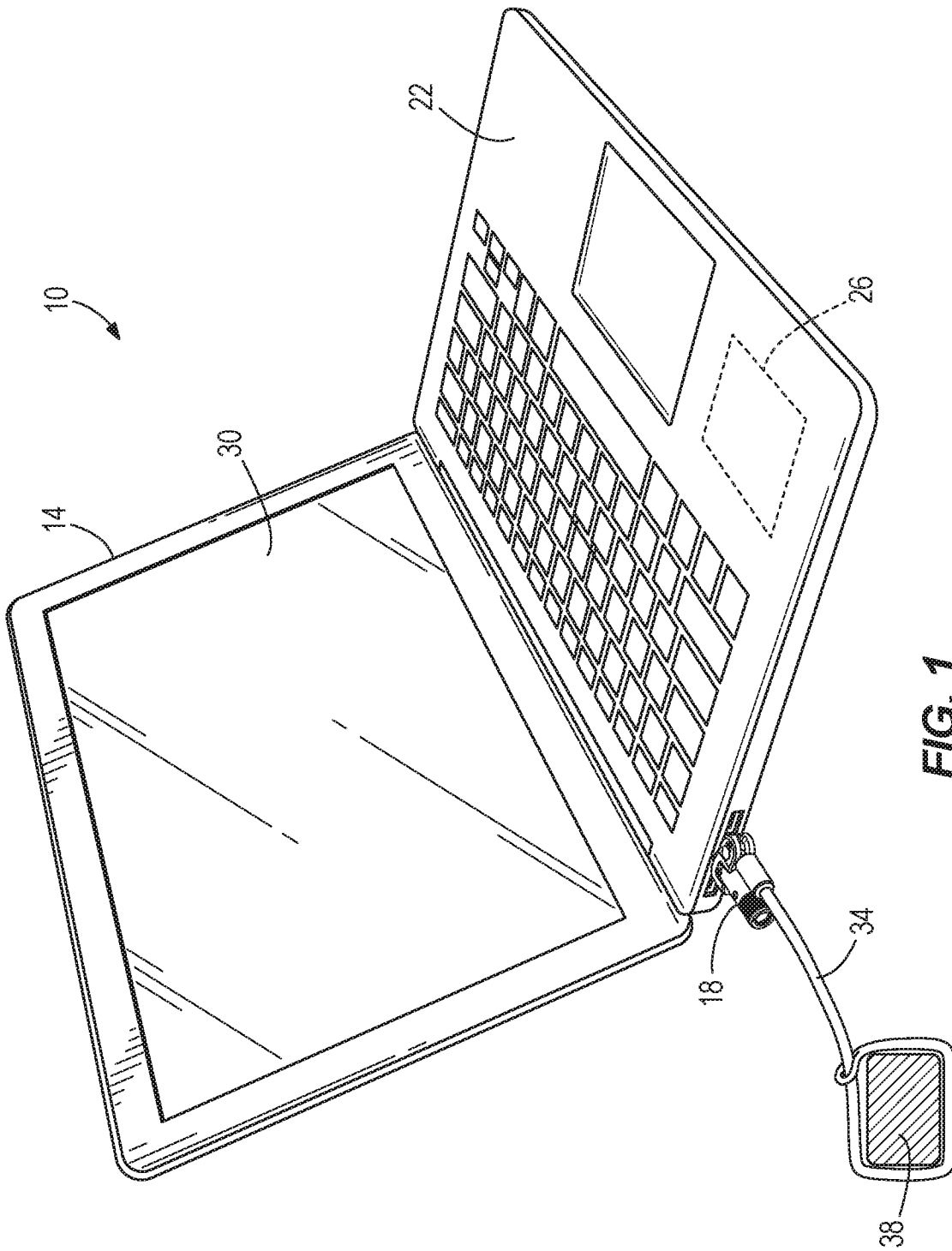
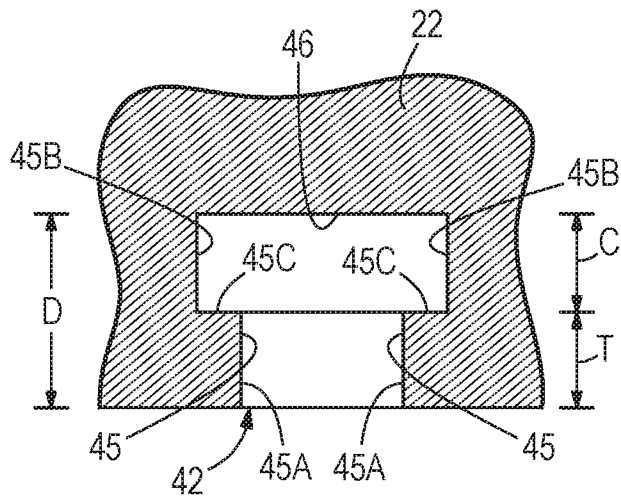
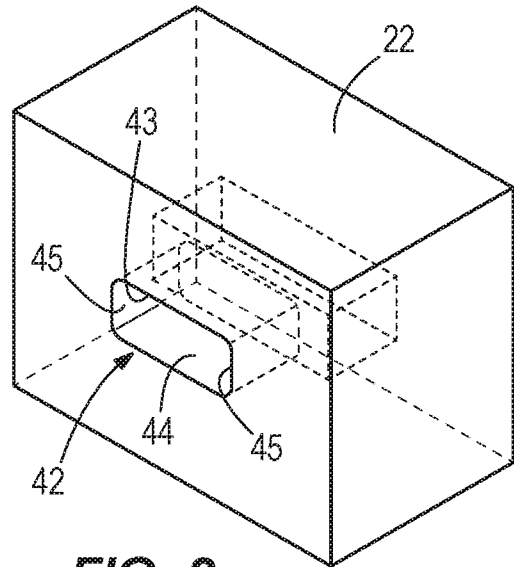

FIG. 1



**FIG. 4**



**FIG. 2**

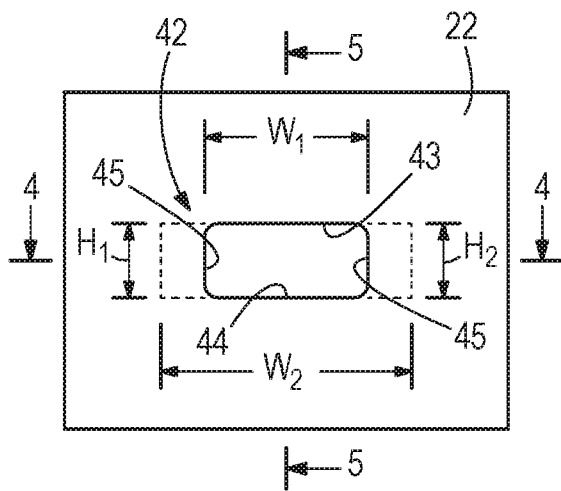

**FIG. 3**

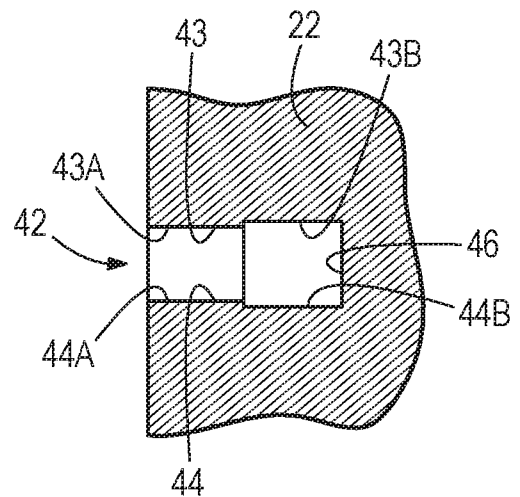

**FIG. 5**

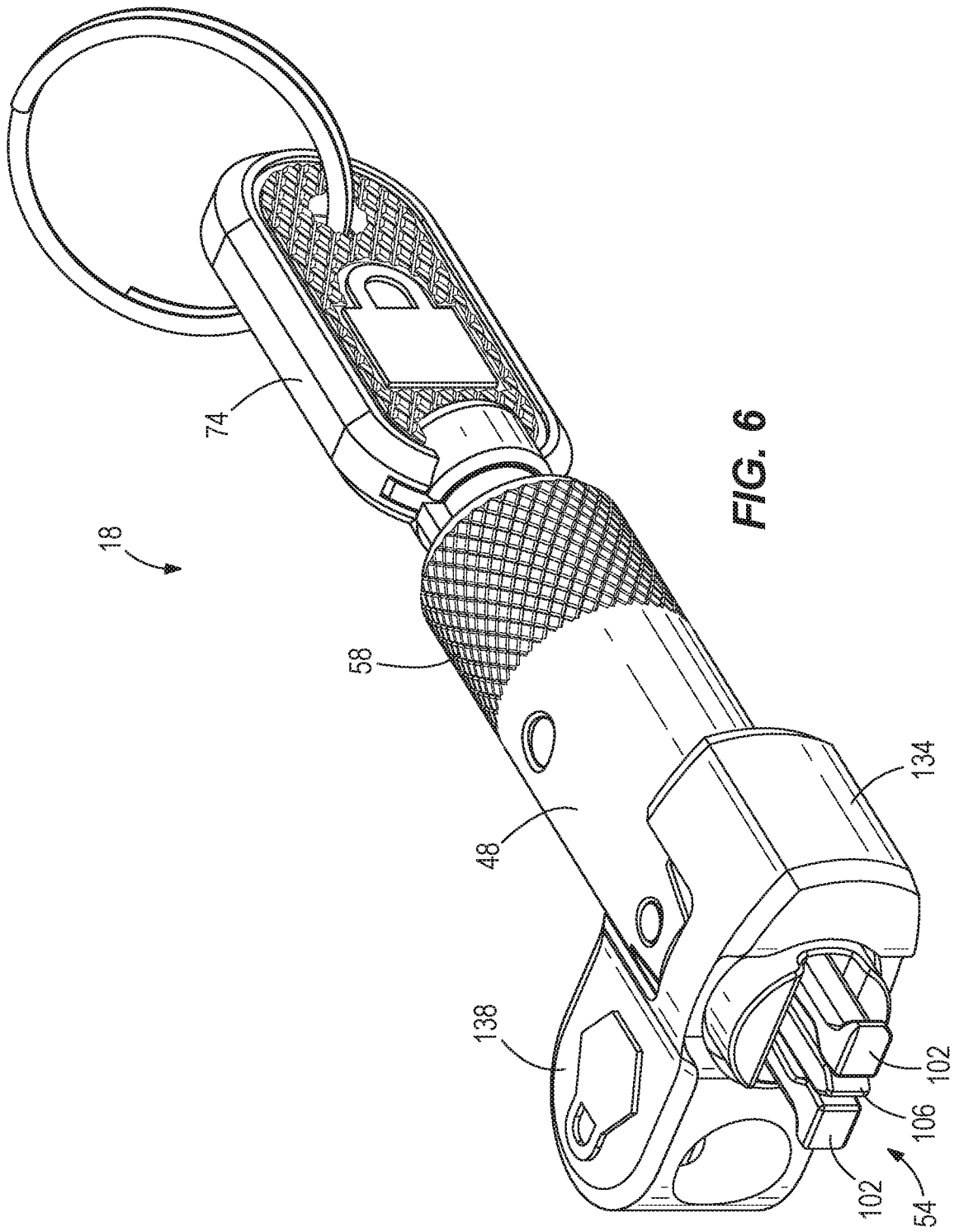

FIG. 6

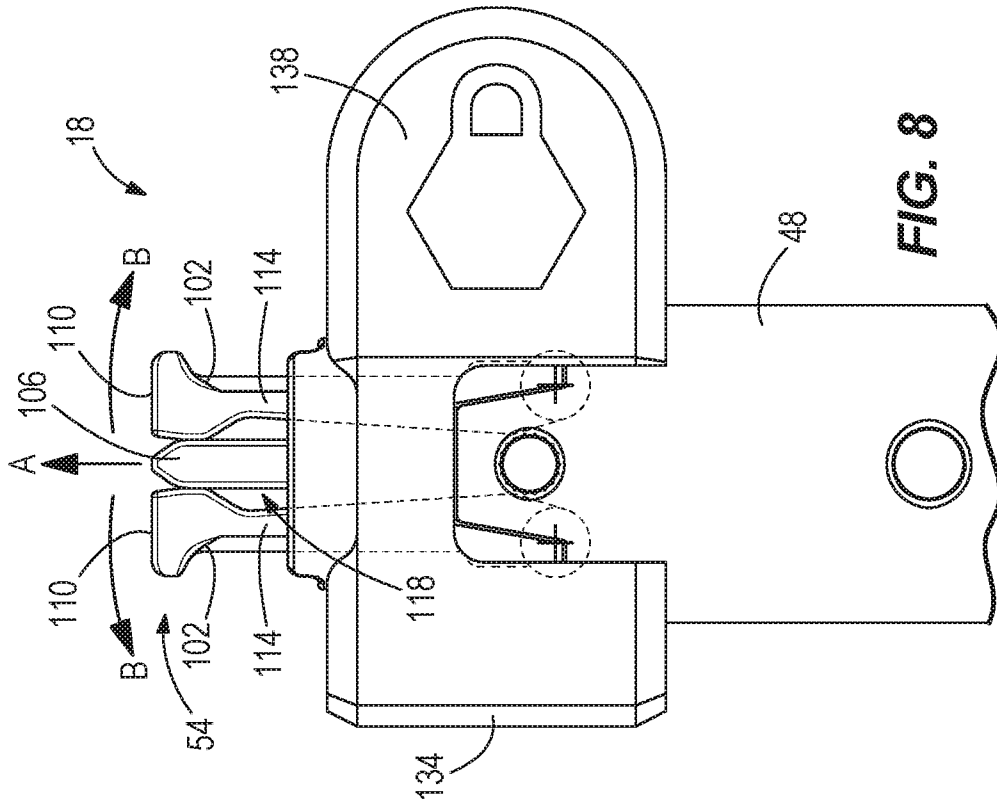

FIG. 8

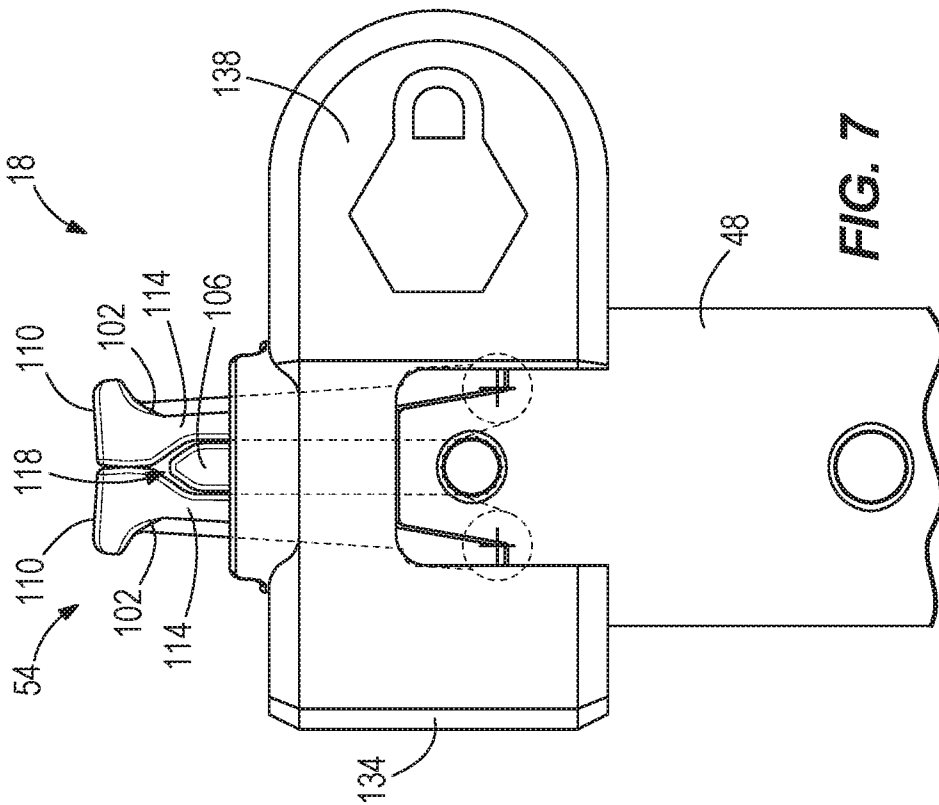
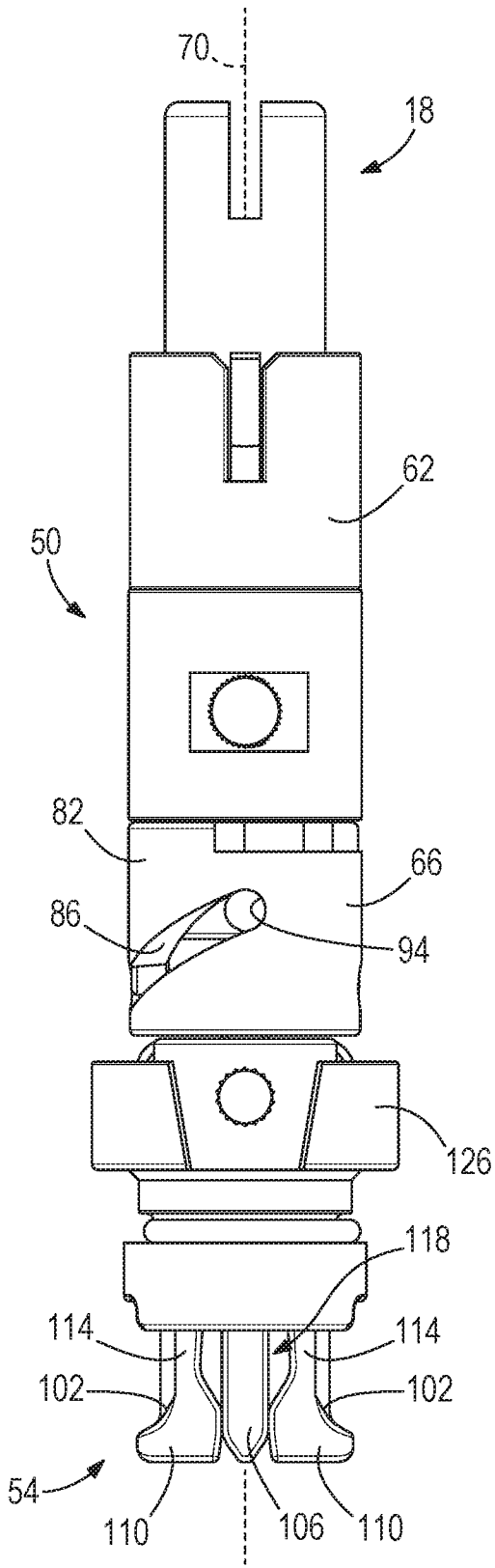
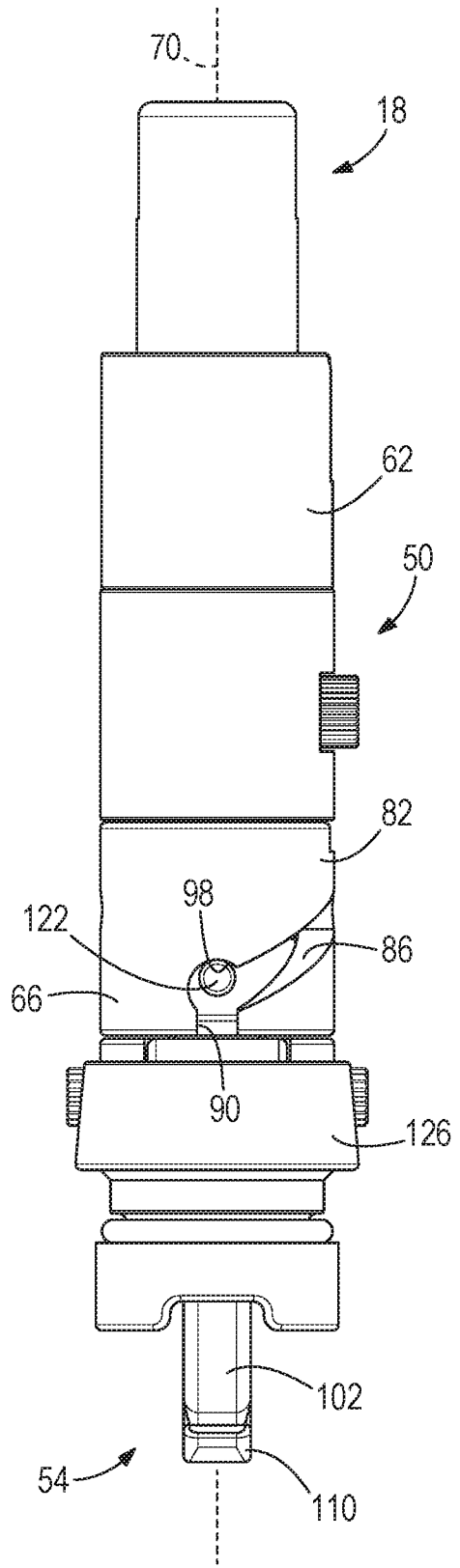

FIG. 7



**FIG. 9**



**FIG. 10**

6/14

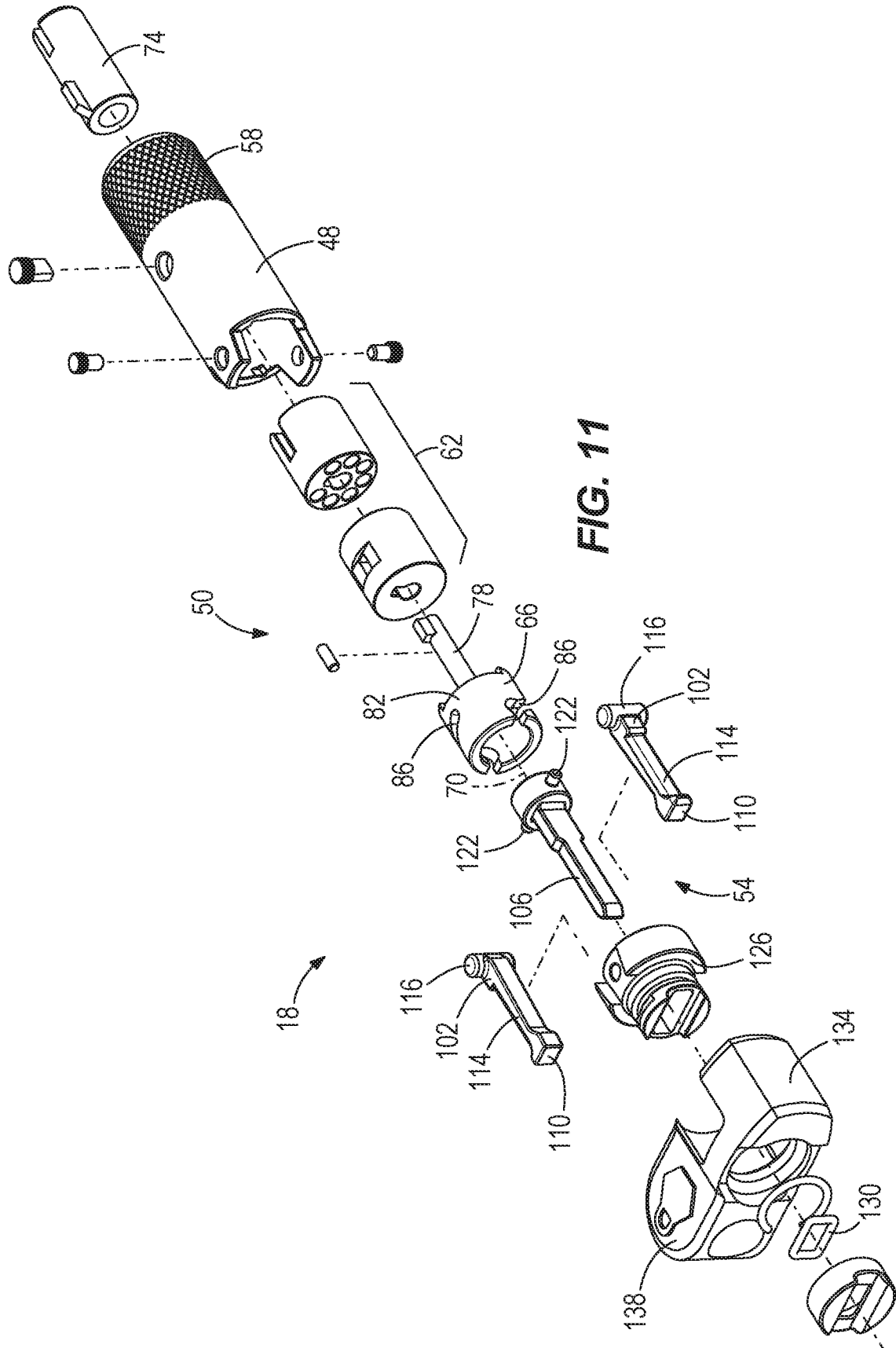
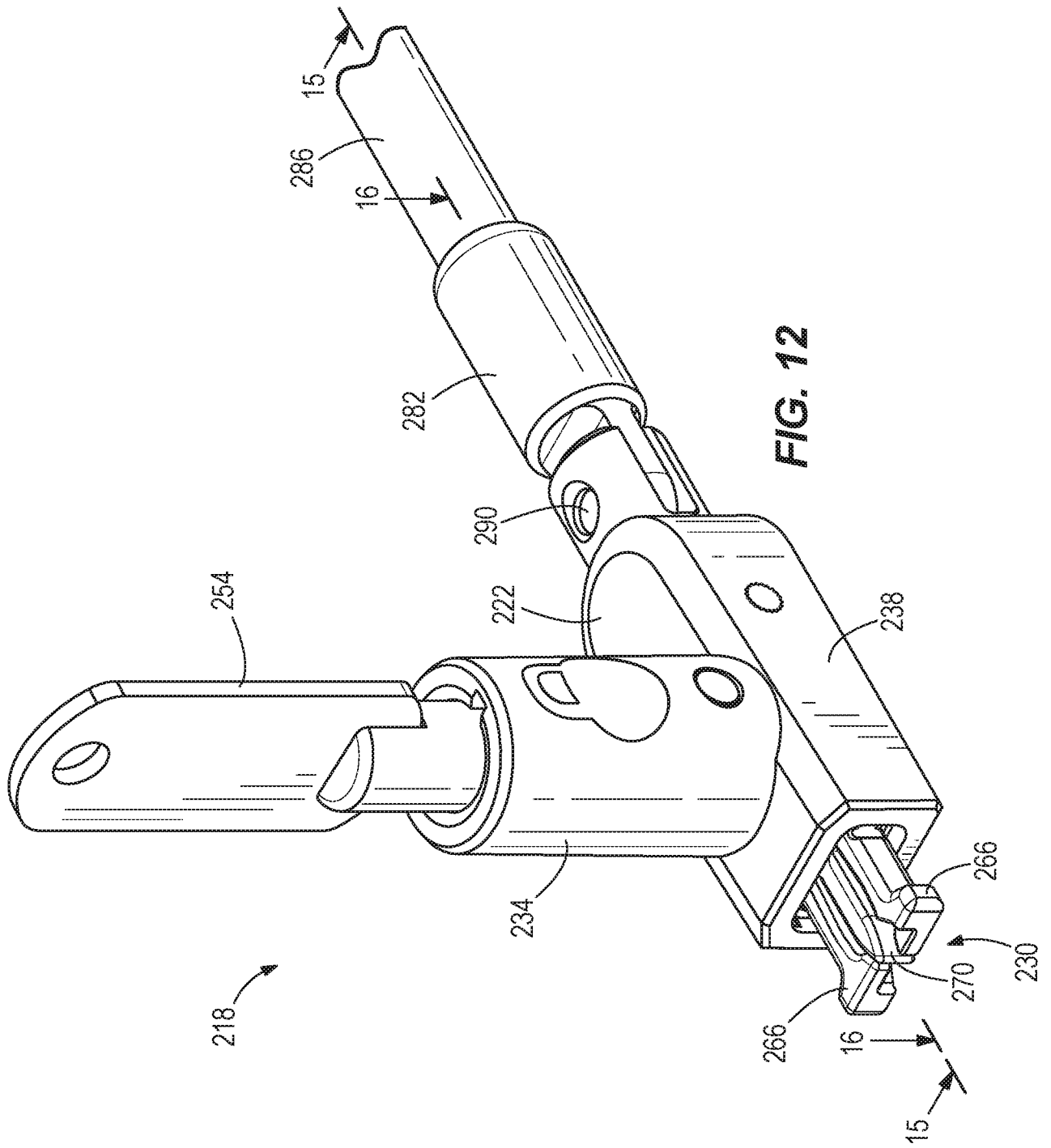

FIG. 11

7/14



8/14

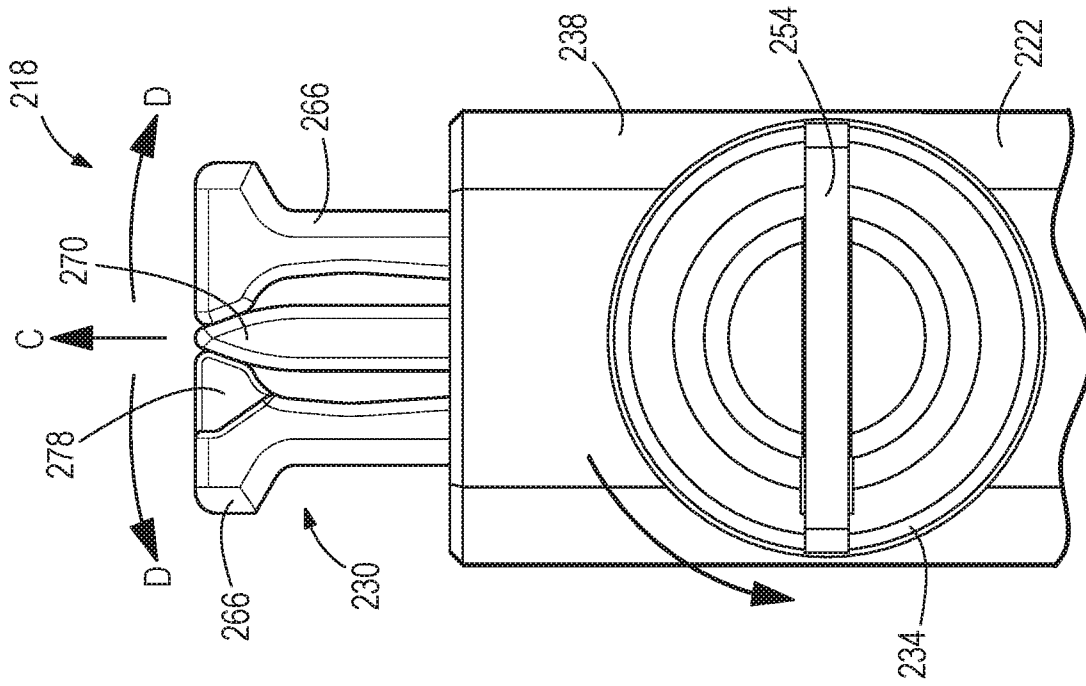

FIG. 13

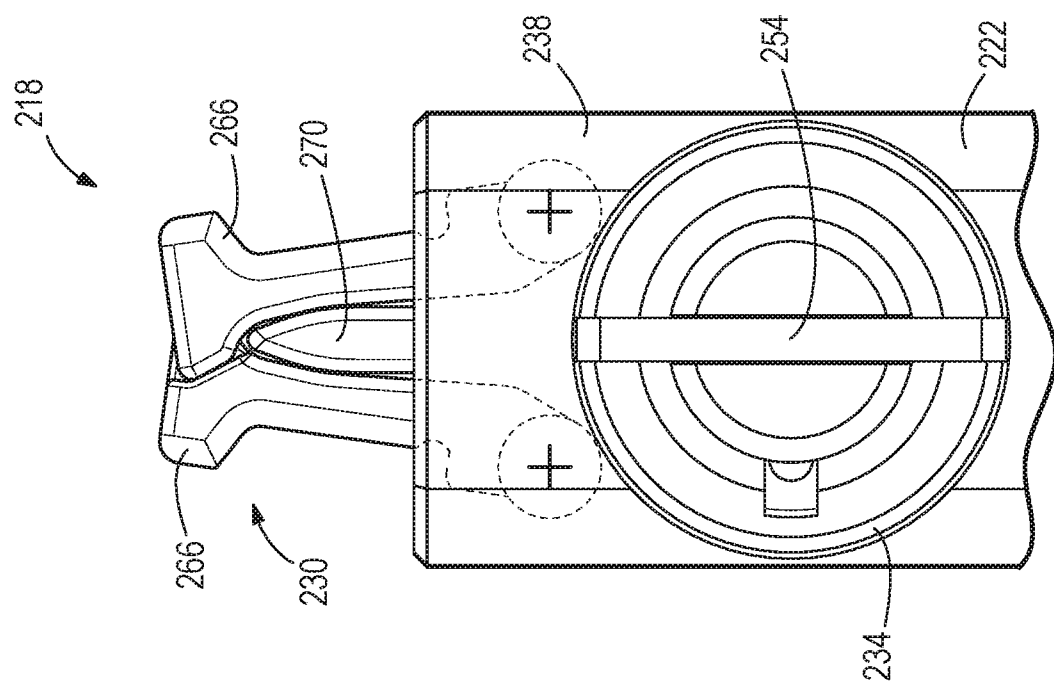

FIG. 14

9/14

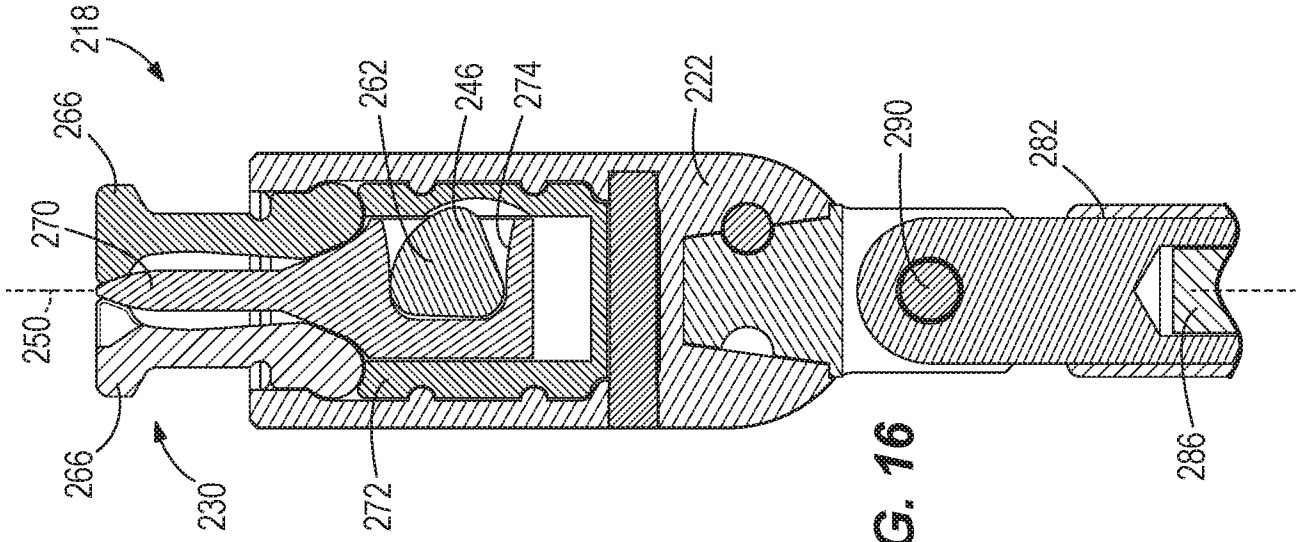

FIG. 16

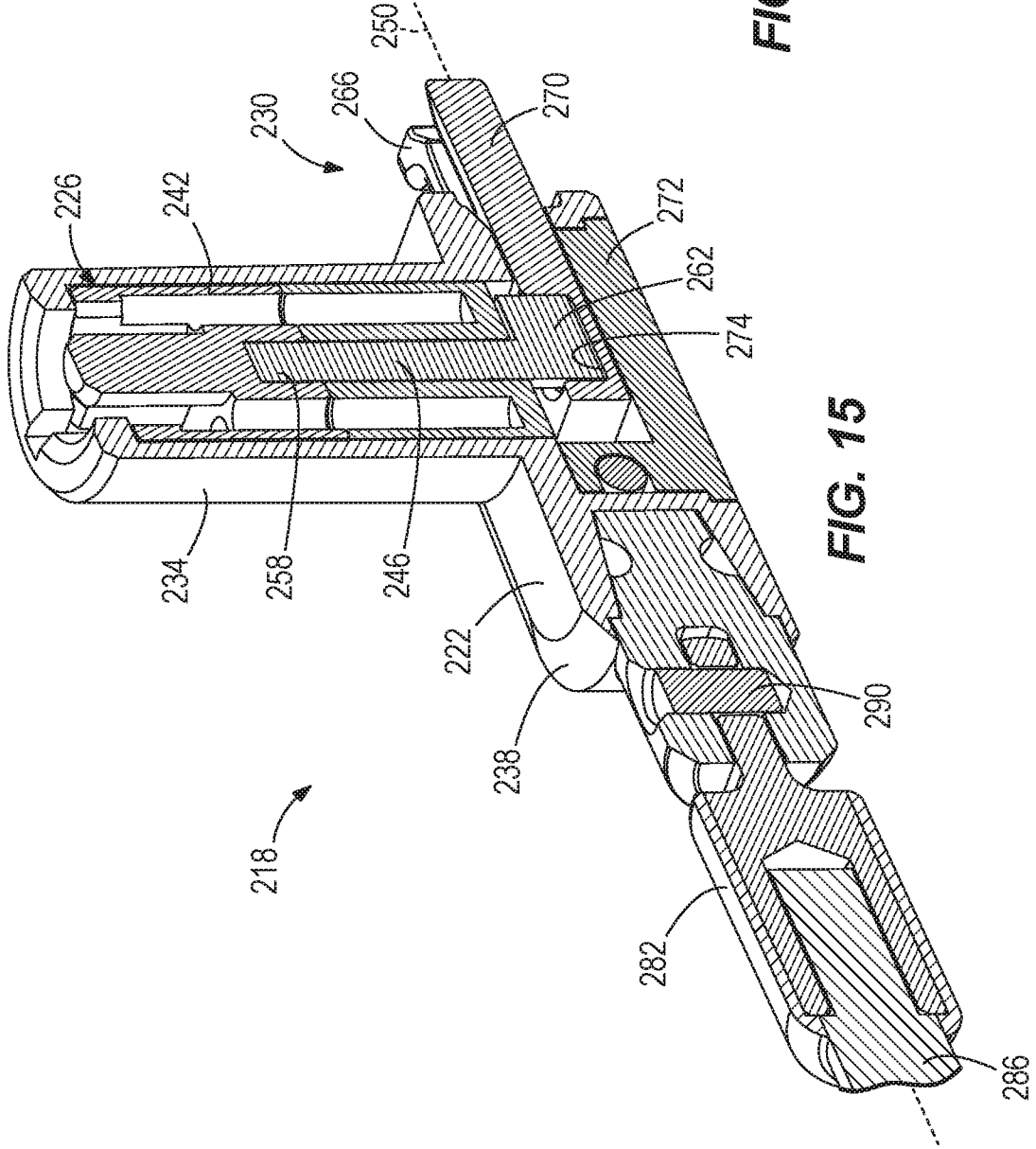
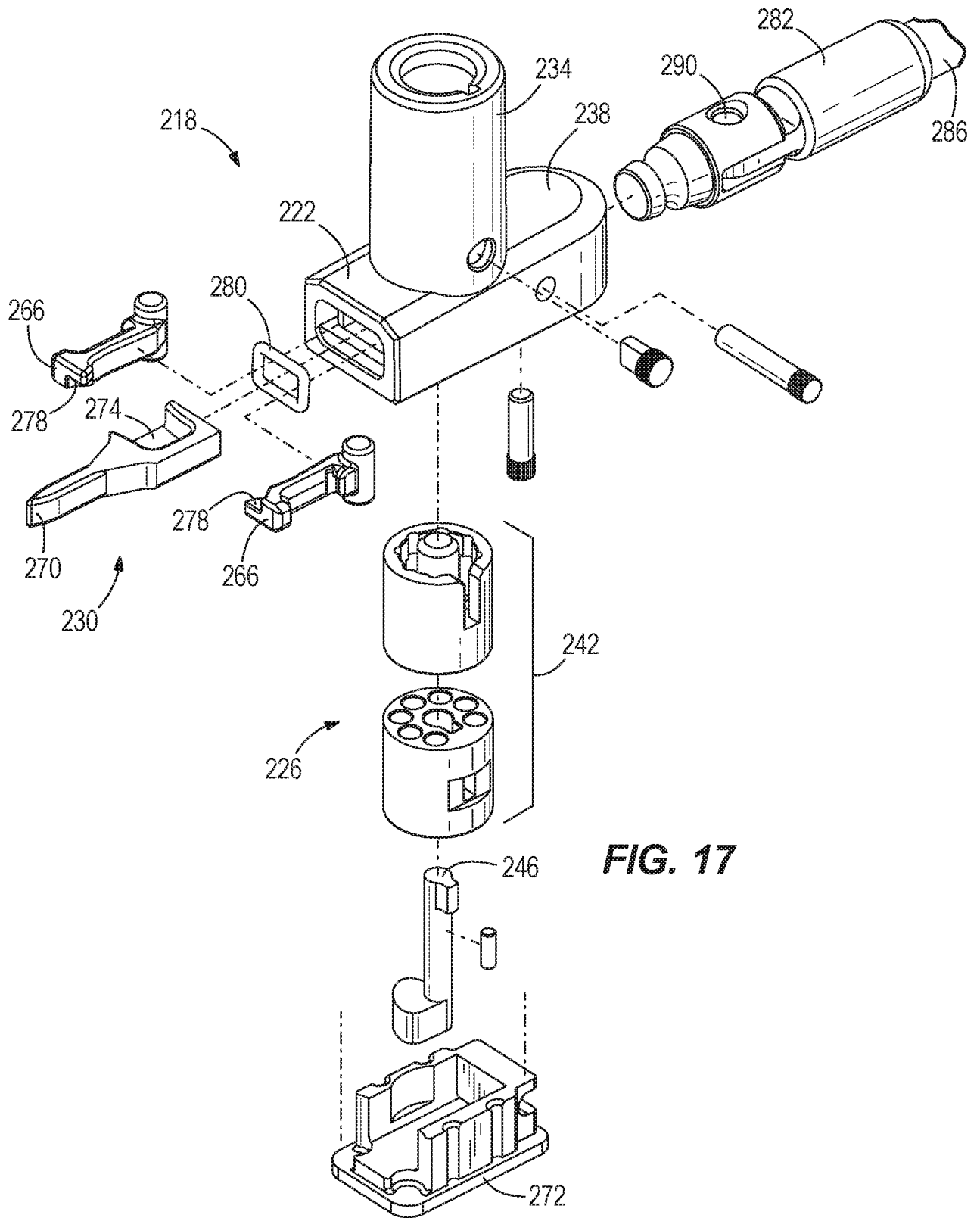

FIG. 15

10/14



**FIG. 17**



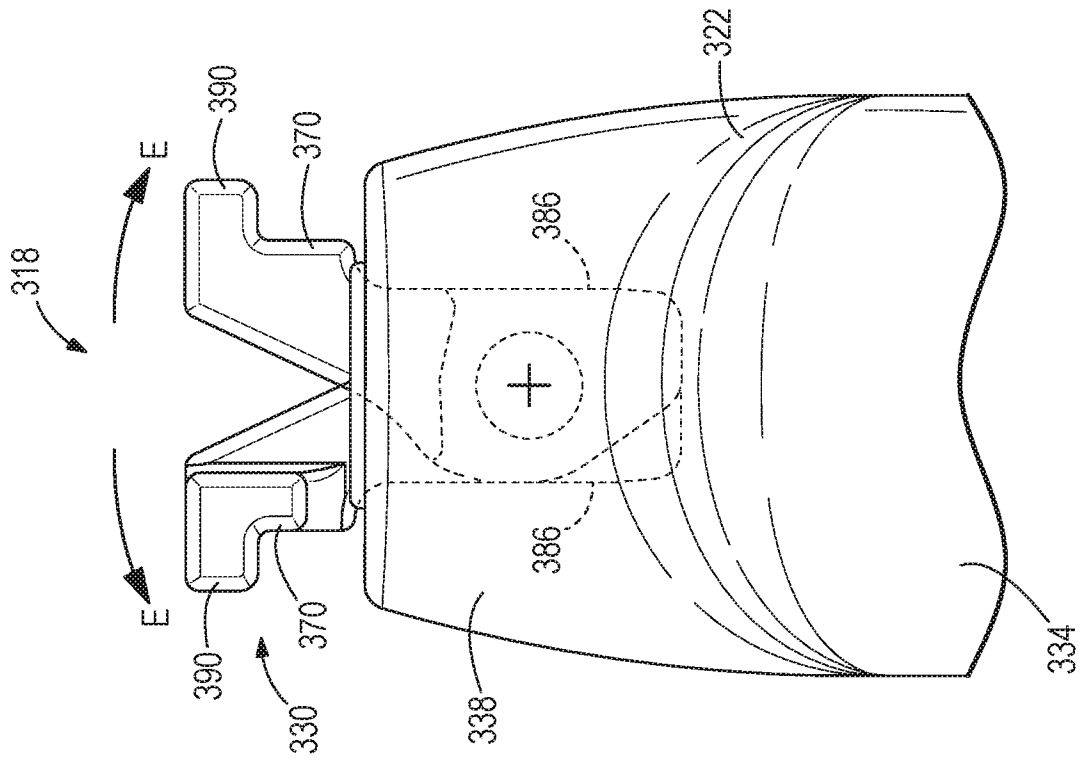

FIG. 20

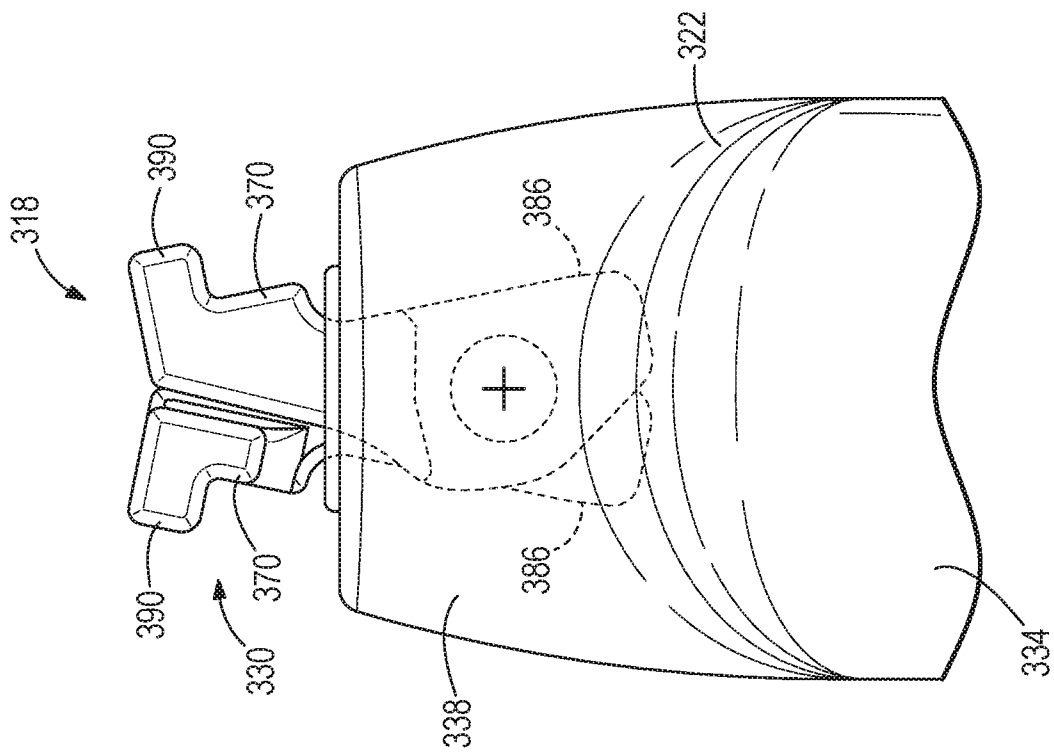

FIG. 19

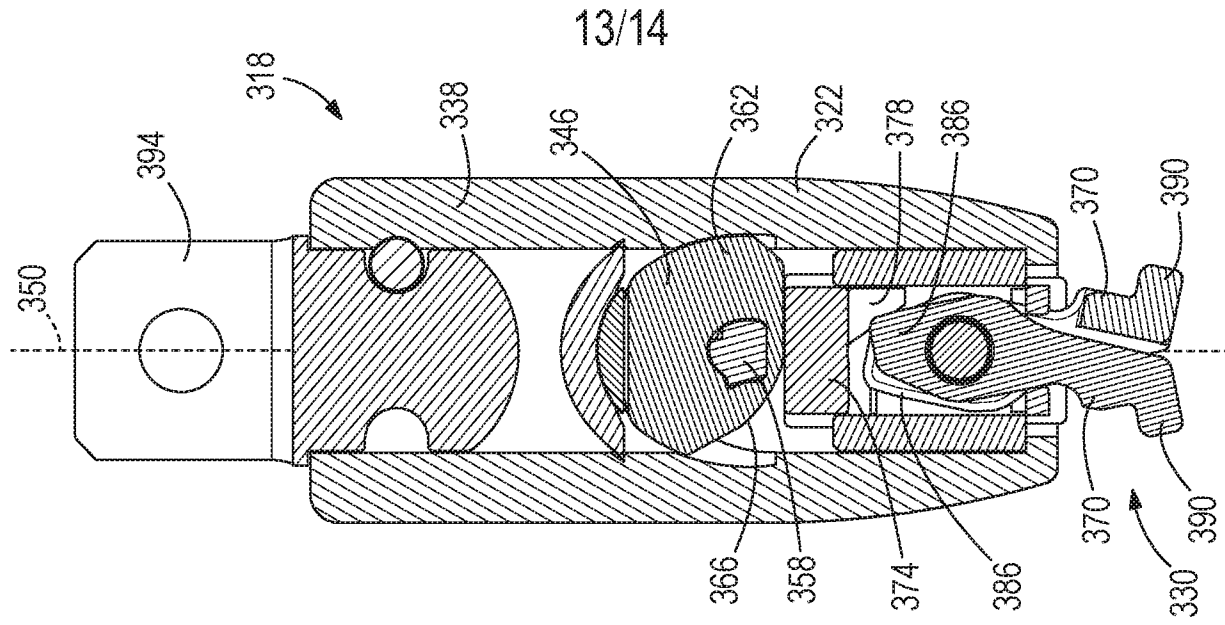

FIG. 22

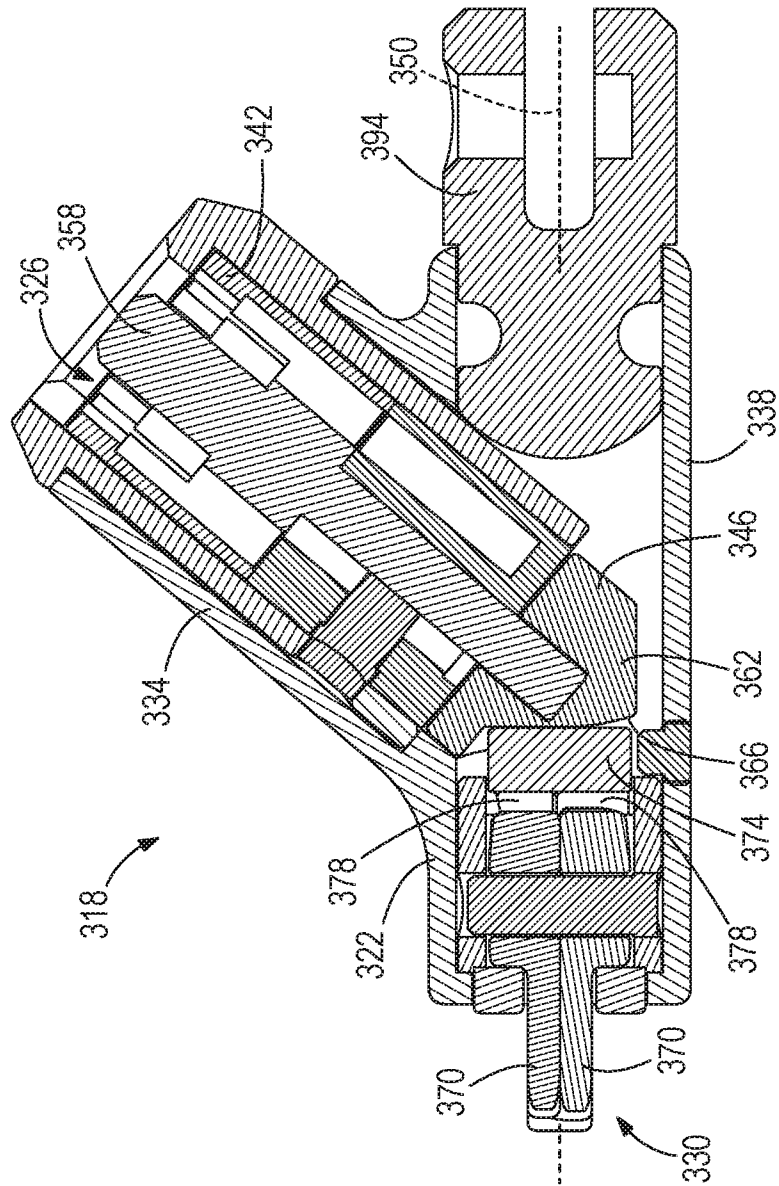
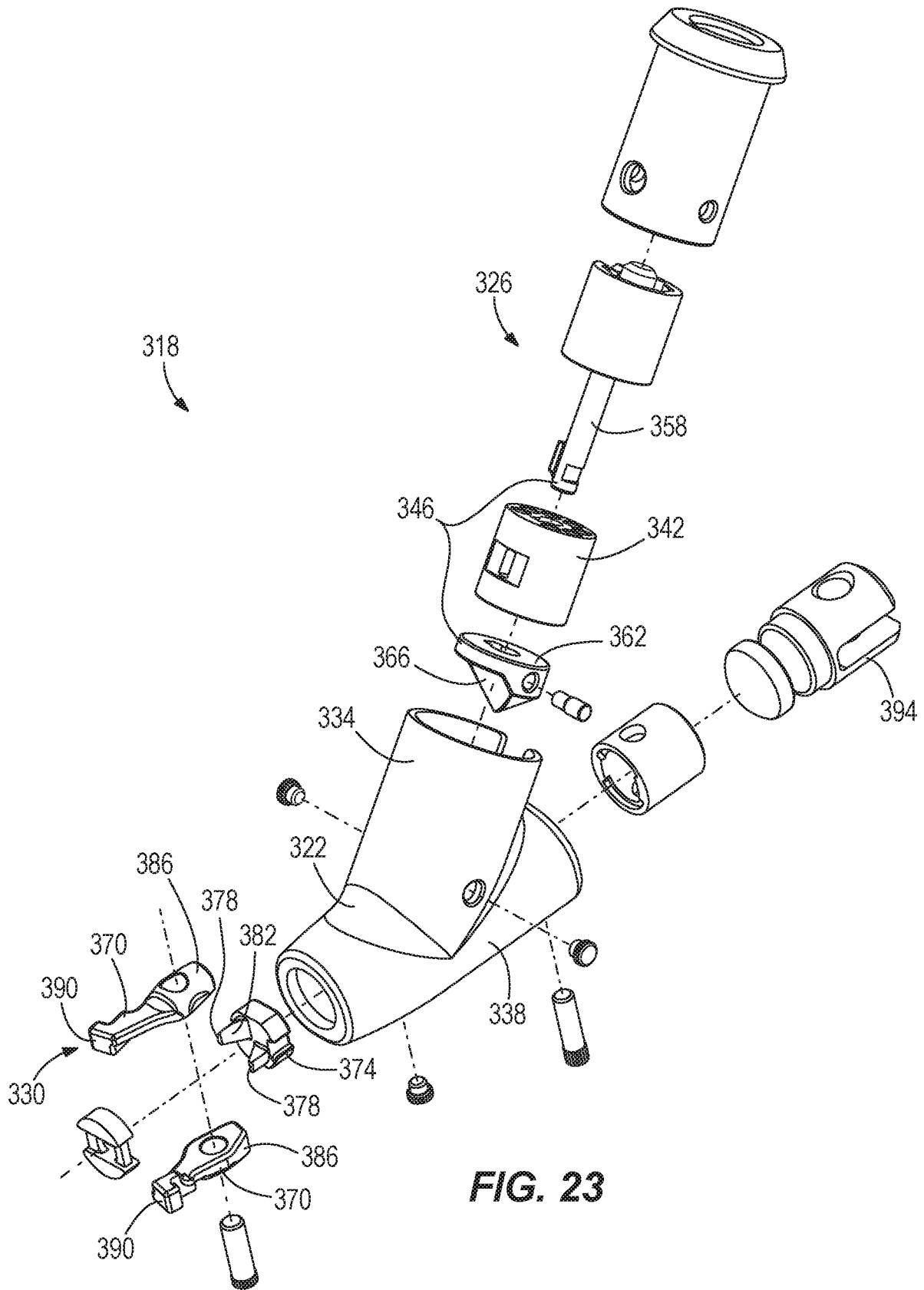

FIG. 21

14/14



**FIG. 23**

**A. CLASSIFICATION OF SUBJECT MATTER****E05B 73/00(2006.01)i, E05B 67/08(2006.01)i**

According to International Patent Classification (IPC) or to both national classification and IPC

**B. FIELDS SEARCHED**Minimum documentation searched (classification system followed by classification symbols)  
E05B 73/00; G06F 1/16; E05B 67/08Documentation searched other than minimum documentation to the extent that such documents are included in the fields searched  
Korean utility models and applications for utility models  
Japanese utility models and applications for utility modelsElectronic data base consulted during the international search (name of data base and, where practicable, search terms used)  
eKOMPASS(KIPO internal) & Keywords: security, portable, aperture, lock, cylinder, cam, slot, engagement, finger and plunger**C. DOCUMENTS CONSIDERED TO BE RELEVANT**

Category*	Citation of document, with indication, where appropriate, of the relevant passages	Relevant to claim No.
Y	US 9187934 B1 (ABA UFO INTERNATIONAL CORP.) 17 November 2015 See column 2, line 15 - column 5, line 19 and figures 1-6.	1-20
Y	US 2014-0026625 A1 (SINOX CO., LTD.) 30 January 2014 See paragraphs [0030]-[0037] and figures 2A-6B.	1-20
A	US 2015-0059422 A1 (ACCO BRANDS CORPORATION) 05 March 2015 See paragraphs [0063]-[0128] and figures 1-52.	1-20
A	US 2003-0106349 A1 (BROADBRIDGE, ALAN CLIVE et al.) 12 June 2003 See paragraphs [0022]-[0039] and figures 1-24.	1-20
A	JP 2007-332578 A (KYT K.K. et al.) 27 December 2007 See paragraphs [0012]-[0039] and figures 1-9.	1-20

 Further documents are listed in the continuation of Box C. See patent family annex.

\* Special categories of cited documents:

"A" document defining the general state of the art which is not considered to be of particular relevance

"E" earlier application or patent but published on or after the international filing date

"L" document which may throw doubts on priority claim(s) or which is cited to establish the publication date of another citation or other special reason (as specified)

"O" document referring to an oral disclosure, use, exhibition or other means

"P" document published prior to the international filing date but later than the priority date claimed

"T" later document published after the international filing date or priority date and not in conflict with the application but cited to understand the principle or theory underlying the invention

"X" document of particular relevance; the claimed invention cannot be considered novel or cannot be considered to involve an inventive step when the document is taken alone

"Y" document of particular relevance; the claimed invention cannot be considered to involve an inventive step when the document is combined with one or more other such documents, such combination being obvious to a person skilled in the art

"&amp;" document member of the same patent family

Date of the actual completion of the international search

25 May 2017 (25.05.2017)

Date of mailing of the international search report

**25 May 2017 (25.05.2017)**

Name and mailing address of the ISA/KR

International Application Division  
Korean Intellectual Property Office  
189 Cheongsa-ro, Seo-gu, Daejeon, 35208, Republic of Korea

Facsimile No. +82-42-481-8578

Authorized officer

KIM, Jin Ho

Telephone No. +82-42-481-8699



**INTERNATIONAL SEARCH REPORT**

Information on patent family members

International application No.

**PCT/US2017/018698**

Patent document cited in search report	Publication date	Patent family member(s)	Publication date
US 9187934 B1	17/11/2015	None	
US 2014-0026625 A1	30/01/2014	CN 203584061 U DE 202013006623 U1 JP 3188496 U US 9574378 B2	07/05/2014 05/09/2013 30/01/2014 21/02/2017
US 2015-0059422 A1	05/03/2015	CN 104563676 A EP 2843165 A2 EP 2843165 A3 TW 201522763 A US 2015-240532 A1 US 9062476 B2	29/04/2015 04/03/2015 13/04/2016 16/06/2015 27/08/2015 23/06/2015
US 2003-0106349 A1	12/06/2003	AU 2001-21935 A1 DE 60019961 T2 EP 1238178 A1 EP 1238178 B1 GB 2357314 A WO 01-44607 A1	25/06/2001 23/02/2006 11/09/2002 04/05/2005 20/06/2001 21/06/2001
JP 2007-332578 A	27/12/2007	JP 4791893 B2	12/10/2011