

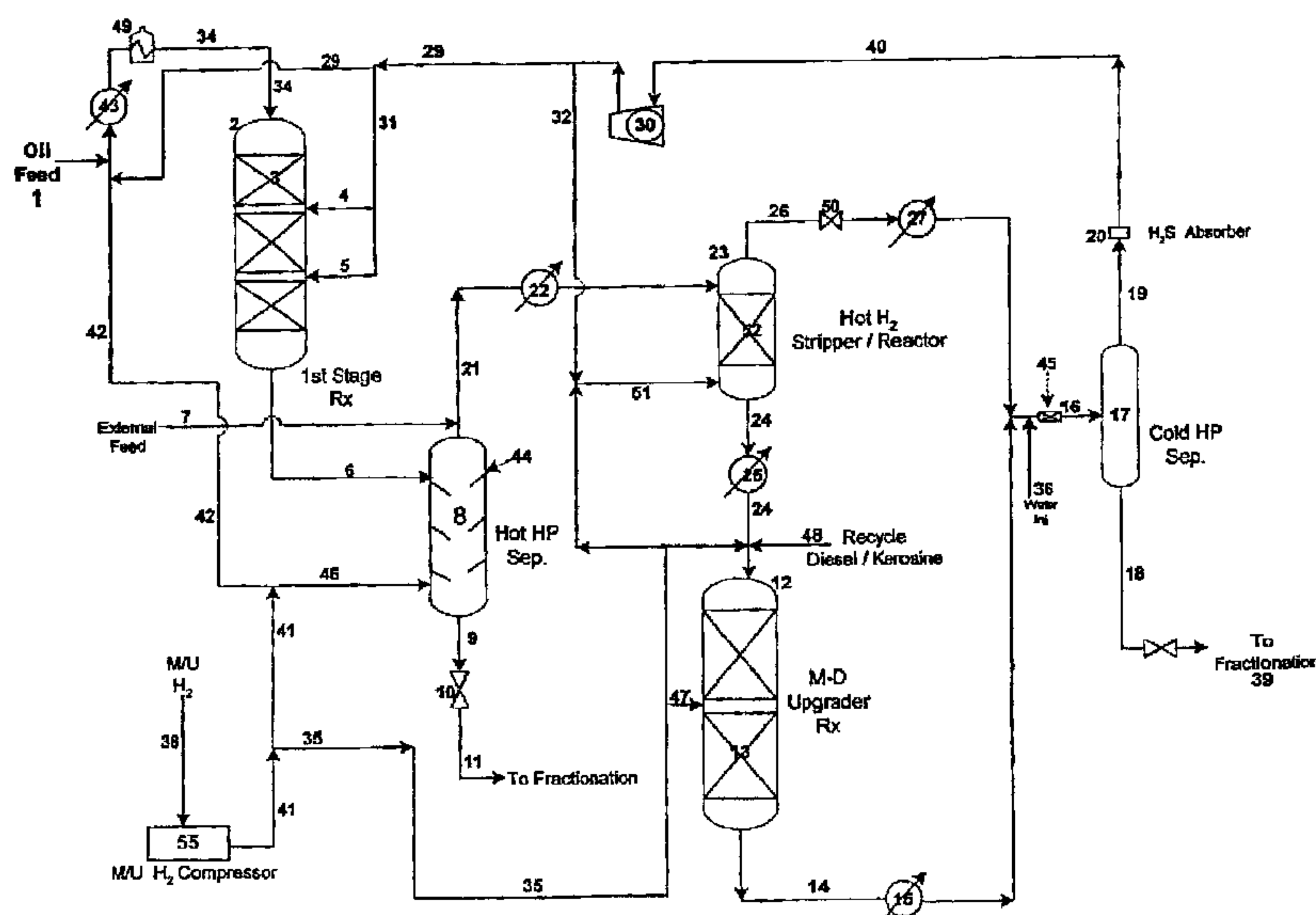

(22) Date de dépôt/Filing Date: 2002/12/11
 (41) Mise à la disp. pub./Open to Public Insp.: 2003/06/17
 (45) Date de délivrance/Issue Date: 2009/09/15
 (30) Priorité/Priority: 2001/12/17 (US10/025,411)

(51) Cl.Int./Int.Cl. *C10G 65/12* (2006.01)
 (72) Inventeurs/Inventors:
 MUKHERJEE, UJJAL KUMAR, US;
 LOUIE, WAI SEUNG W., US;
 DAHLBERG, ARTHUR J., US
 (73) Propriétaire/Owner:
 CHEVRON U.S.A. INC., US
 (74) Agent: SIM & MCBURNEY

(54) Titre : METHODE DE PRODUCTION DE DISTILLATS MOYENS DE QUALITE SUPERIEURE EN UTILISANT DES HYDROCRAQUEURS DANS DES CONDITIONS DOUCES ET DES APPAREILS D'HYDROTRAITEMENT DE GAZOLE SOUS VIDE, AINSI QUE DES MATIERES D'ALIMENTATION EXTERNES SE SITUANT DANS L'INTERVALLE D'EBULLITION DES DISTILLATS MOYENS
 (54) Title: PROCESS FOR THE PRODUCTION OF HIGH QUALITY MIDDLE DISTILLATES FROM MILD HYDROCRACKERS AND VACUUM GAS OIL HYDROTREATERS IN COMBINATION WITH EXTERNAL FEEDS IN THE MIDDLE DISTILLATE BOILING RANGE



(57) **Abrégé/Abstract:**

In the refining of crude oil, vacuum gas oil hydrotreaters and hydrocrackers are used to remove impurities such as sulfur, nitrogen, and metals from the crude oil. Typically, the middle distillate boiling material (boiling in the range- from 250°F-735°F) from VGO hydrotreating or moderate severity hydrocrackers does not meet the smoke point, the cetane number or the aromatic specification. In most cases, this middle distillate is separately upgraded by a middle distillate hydrotreater or, alternatively, the middle distillate is blended into the general fuel oil pool or used as home heating oil. With this invention, the middle distillate is hydrotreated in the same high pressure loop as the vacuum gas oil hydrotreating reactor or the moderate severity hydrocracking reactor. The investment cost saving and/or utilities saving are significant since a separate middle distillate hydrotreater is not required. A major benefit of this invention is the potential for simultaneously upgrading difficult cracked stocks such as Light Cycle Oil, Light Coker Gas Oil and Visbroken Gas Oil or Straight-Run Atmospheric Gas Oils utilizing the high-pressure environment required for mild hydrocracking.

1 **PROCESS FOR THE PRODUCTION OF HIGH QUALITY MIDDLE**
2 **DISTILLATES FROM MILD HYDROCRACKERS AND VACUUM GAS OIL**
3 **HYDROTREATERS IN COMBINATION WITH EXTERNAL FEEDS IN THE**
4 **MIDDLE DISTILLATE BOILING RANGE**

5

6

FIELD OF THE INVENTION

7

8 This invention is directed to processes for upgrading the fraction boiling in the
9 middle distillate range which is obtained from VGO hydrotreaters or moderate
10 severity hydrocrackers. This invention involves a multiple-stage process
11 employing a single hydrogen loop.

12

13

BACKGROUND OF THE INVENTION

14

15 In the refining of crude oil, vacuum gas oil hydrotreaters and hydrocrackers
16 are used to remove impurities such as sulfur, nitrogen, and metals from the
17 crude oil. Typically, the middle distillate boiling material (boiling in the range
18 from 250°F-735°F) from VGO hydrotreating or moderate severity
19 hydrocrackers does not meet the smoke point, the cetane number or the
20 aromatic specification. In most cases, this middle distillate is separately
21 upgraded by a middle distillate hydrotreater or, alternatively, the middle
22 distillate is blended into the general fuel oil pool or used as home heating oil.
23 There are also streams in the diesel boiling range, from other units such as
24 Fluid Catalytic Cracking, Delayed Coking and Visbreaking that require
25 upgrading. Very often, existing diesel hydrotreaters are not designed to the
26 pressure limits required to process these streams and the mild hydrocracking
27 unit provides an opportunity for simultaneous upgrading of these streams.

28

29 There have been some previously disclosed processes in which
30 hydroprocessing occurs within a single hydroprocessing loop. International
31 Publication No. WO 97/38066 (PCT/US97/04270), published October 16,
32 1997, discloses a process for reverse staging in hydroprocessing reactor
33 systems. This hydroprocessor reactor system comprises two reactor zones,

1 one on top of the other, in a single reaction loop. In the preferred
2 embodiment, a hydrocarbon feed is passed to a denitrification and
3 desulfurization zone, which is the lower zone. The effluent of this zone is
4 cooled and the gases are separated from it. The liquid product is then passed
5 to the upper zone, where hydrocracking or hydrotreating may occur. Deeper-
6 treating preferably occurs in the upper zone.

7

8 U.S. Pat. No. 5,980,729 discloses a configuration similar to that of
9 WO 97/38066. A hot stripper is positioned downstream from the
10 denitrification/desulfurization zone, however. Following this stripper is an
11 additional hydrotreater. There is also a post-treat reaction zone downstream
12 of the denitrification/desulfurization zone in order to saturate aromatic
13 compounds. U.S. Pat. No. 6,106,694 discloses a similar configuration to that
14 of U.S. Pat. No. 5,980,729, but without the hydrotreater following the stripper
15 and the post-treat reaction zone.

16

17

SUMMARY OF THE INVENTION

18

19 With this invention, the middle distillate is hydrotreated in the same high
20 pressure loop as the vacuum gas oil hydrotreating reactor or the moderate
21 severity hydrocracking reactor, but the reverse staging configuration
22 employed in the references is not employed in the instant invention. The
23 investment cost saving and/or utilities saving involved in the use of a single
24 hydrogen loop are significant since a separate middle distillate hydrotreater is
25 not required. Other advantages include optimal hydrogen pressures for each
26 step, as well as optimal hydrogen consumption and usage for each product.
27 There is also a maximum yield of upgraded product, without the use of recycle
28 liquid. The invention is summarized below.

29

30 A method for hydroprocessing a hydrocarbon feedstock, said method
31 employing at least two reaction zones within a single reaction loop,
32 comprising the following steps:

33

- 1 (a) passing a hydrocarbonaceous feedstock to a first hydroprocessing zone
2 having one or more beds containing hydroprocessing catalyst, the
3 hydroprocessing zone being maintained at hydroprocessing conditions,
4 wherein the feedstock is contacted with catalyst and hydrogen;
5
- 6 (b) passing the effluent of step (a) directly to a hot high pressure separator,
7 wherein the effluent is contacted with a hot, hydrogen-rich stripping gas
8 to produce a vapor stream comprising hydrogen, hydrocarbonaceous
9 compounds boiling at a temperature below the boiling range of the
10 hydrocarbonaceous feedstock, hydrogen sulfide and ammonia and a
11 liquid stream comprising hydrocarbonaceous compounds boiling
12 approximately in the range of said hydrocarbonaceous feedstock;
13
- 14 (c) passing the vapor stream of step (b), after cooling and partial
15 condensation, to a hot hydrogen stripper containing at least one bed of
16 hydrotreating catalyst, where it is contacted countercurrently with
17 hydrogen, while the liquid stream of step (b) is passed to fractionation;
18
- 19 (d) passing the overhead vapor stream from the hot hydrogen stripper of
20 step (c), after cooling and contacting with water, the overhead vapor
21 stream comprising hydrogen, ammonia, and hydrogen sulfide, along with
22 light gases and naphtha to a cold high pressure separator, where
23 hydrogen, hydrogen sulfide and light hydrocarbonaceous gases are
24 removed overhead, ammonia is removed from the cold high pressure
25 separator as ammonium bisulfide in the sour water stripper, and naphtha
26 and middle distillates are passed to fractionation;
27
- 28 (e) passing the liquid stream from the hot hydrogen stripper of step (c) to a
29 second hydroprocessing zone, the second hydroprocessing zone
30 containing at least one bed of hydroprocessing catalyst suitable for
31 aromatic saturation and ring opening, wherein the liquid is contacted
32 under hydroprocessing conditions with the hydroprocessing catalyst, in
33 the presence of hydrogen;

- 1 (f) passing the overhead from the cold high pressure separator of step (d)
2 to an absorber, where hydrogen sulfide is removed before hydrogen is
3 compressed and recycled to hydroprocessing vessels within the loop;
4 and
5
6 (g) passing the effluent of step (e) to the cold high pressure separator of
7 step (d).

8

9

BRIEF DESCRIPTION OF THE DRAWINGS

10

11 Figure 1 illustrates a hydroprocessing loop in which the post-treatment reactor
12 is a middle distillate upgrader which operates at approximately the same
13 pressure as the first stage reactor.

14

15 Figure 2 illustrates a hydroprocessing loop in which the post-treatment reactor
16 is the same as that of Figure 1, but operates at lower pressure than the first
17 stage reactor. A noble metal catalyst is used in the post-treatment reactor.

18

19

DETAILED DESCRIPTION OF THE INVENTION

20

21 Description of the Preferred Embodiment

22

Description of Figure 1

24

25 Feed in stream 1 is mixed with recycle hydrogen and make-up hydrogen in
26 stream 42. The feed has been preheated in a process heat exchanger train,
27 as are the gas streams. The mixture of feed and gas, now in stream 34, is
28 further heated using heat exchangers 43 and furnace 49. Stream 34 then
29 enters the first stage downflow fixed bed reactor 2. The first bed 3 of reactor
30 2 may contain VGO hydrotreater catalyst or a moderate severity hydrocracker
31 catalyst. There may be a succession of fixed beds 3, with interstage quench
32 streams, 4 and 5 delivering hydrogen in between the beds.

1 The effluent 6 of the first stage reactor 2, which has been hydrotreated and
2 partially hydrocracked, contains hydrogen sulfide, ammonia, light gases,
3 naphtha, middle distillate and hydrotreated vacuum gas oil. The effluent
4 enters the hot high pressure separator or flash zone 8 at heavy oil reactor
5 effluent conditions where part of the diesel and most of the lighter material is
6 separated from the unconverted oil. The hot high pressure separator has a
7 set of trays 44 with hydrogen rich gas introduced at the bottom for stripping
8 through stream 46.

9

10 Stream 9 is primarily hydrotreated heavy gas oil, boiling at temperatures
11 greater than 700°F. The valve 10 indicates that pressure is reduced before
12 the unconverted oil is sent to the fractionation section in stream 11.

13

14 Stream 21 contains the overhead from the hot high pressure separator.
15 Stream 21 is cooled in exchanger 22 (by steam generation or process heat
16 exchange) before entering the hot hydrogen stripper/reactor 23. Stream 21
17 flows downwardly through a bed of hydrotreating catalyst 52, while being
18 contacted with countercurrent flowing hydrogen from stream 51.

19

20 The overhead stream 26 contains hydrogen, ammonia and hydrogen sulfide,
21 along with light gases and naphtha. The differential operating pressure
22 between the hot hydrogen stripper/reactor 23 and cold high pressure
23 separator 17 is maintained by control valve 50. Stream 26 is cooled in
24 exchanger 27 and joins stream 14 to form stream 16. Water is injected
25 (stream 36) into the stream 16 to remove most of the ammonia as ammonium
26 bisulfide solution (ammonia and hydrogen sulfide react to form ammonium
27 bisulfide which is converted to solution by water injection). The stream is then
28 air cooled by cooler 45. The stream 16 enters the cold high pressure
29 separator 17. Hydrogen, light hydrocarbonaceous gases, and hydrogen
30 sulfide are removed overhead through stream 19. Hydrogen sulfide is
31 removed from the stream in the hydrogen sulfide absorber 20. Ammonia and
32 hydrogen sulfide are removed with the sour water stream (not shown) from
33 the cold high pressure separator 17.

1 Stream 40, which contains hydrogen-rich gas, is compressed in compressor
2 30 and splits into streams 29 and 32. Stream 32 passes to the hot hydrogen
3 stripper/reactor 23. Stream 31 is diverted from stream 29 for use as interstage
4 quench. Streams 4 and 5 are diverted from stream 31. Stream 29, containing
5 hydrogen, is combined with hydrogen stream 42 prior to combining with oil
6 feed stream 1.

7
8 Make-up hydrogen 38 is compressed and sent to four separate locations,
9 upstream of reactor 2 to combine with feed stream 1 (through stream 42), to
10 the hot high pressure separator 8 through stream 46, to the hot hydrogen
11 stripper/reactor through stream 51, and to the middle distillate upgrader
12 (stream 35) to combine with recycle diesel or kerosene or to be used as
13 interstage quench. Stream 38, containing make-up hydrogen, passes to the
14 make-up hydrogen compressor 55. From stream 41, which exits compressor
15 55 containing compressed hydrogen, streams 35, 42 and 46 are diverted.

16
17 The middle distillate upgrader 12 consists of one or more multiple beds 13 of
18 hydrotreating/hydrocracking catalyst (such as Ni-Mo, Ni-W and/or noble
19 metal) for aromatic saturation and ring opening to improve diesel product
20 qualities such as aromatic level and cetane index. In the embodiment of
21 Figure 1, the middle distillate upgrader is operated at approximately the same
22 pressure as the first stage reactor 2. Quench gas (stream 47) may be
23 introduced in order to control reactor temperature. Stream 24 may be
24 combined with recycle diesel or kerosene (stream 48) from the fractionator
25 when no other external feeds (stream 7) are to be processed and cooled in
26 exchanger 25. Hydrogen from stream 35 is combined with stream 24 prior to
27 entering the middle distillate upgrader 12. Stream 24 enters the reactor at the
28 top and flows downwardly through the catalyst beds 13.

29
30 Stream 14, which is the effluent from the middle distillate upgrader 12, is used
31 to heat the other process streams in the unit (see exchanger 15) and then
32 joins with stream 26 to form stream 16, which is sent to the effluent air cooler
33 and then to the cold high-pressure separator 17. Water is continuously

1 injected into the inlet piping of the effluent air cooler to prevent the deposition
2 of salts in the air cooler tubes. In the cold high pressure separator 17,
3 hydrogen, hydrogen sulfide and ammonia leave through the overhead stream
4 19, while naphtha and middle distillates exit through stream 18 to fractionation
5 (stream 39).

7 **Description of Figure 2**

8
9 As described in Figure 1, feed in stream 1 is mixed with recycle hydrogen and
10 make-up hydrogen in stream 42. The feed has been preheated in a process
11 heat exchange train as are the gas streams. The mixture of feed and gas,
12 now in stream 34, is further heated using heat exchangers 43 and furnace 49.
13 Stream 34 then enters the first stage downflow fixed bed reactor 2. The first
14 bed 3 of reactor 2 may contain VGO hydrotreater catalyst or a moderate
15 severity hydrocracker catalyst. There may be a succession of fixed beds 3,
16 with interstage quench streams, 4 and 5 delivering hydrogen in between the
17 beds.

18
19 The effluent 6 of the first stage reactor, which has been hydrotreated and
20 partially hydrocracked, contains hydrogen sulfide, ammonia, light gases,
21 naphtha, middle distillate and hydrotreated vacuum gas oil. The effluent
22 enters the hot high pressure separator or flash zone 8 at heavy oil reactor
23 effluent conditions where part of the diesel and most of the lighter material is
24 separated from the unconverted oil. The hot high pressure separator has a set
25 of trays 44 with hydrogen rich gas introduced at the bottom for stripping
26 through stream 46.

27
28 Stream 9 is primarily hydrotreated heavy gas oil, boiling at temperatures
29 greater than 700°F. The valve 10 indicates that pressure is reduced before
30 the unconverted oil is sent to the fractionation section in stream 11.

31
32 Stream 21 contains the overhead from the hot high pressure separator and
33 may be joined by external feed 7. Stream 21 is then cooled in exchanger 22

1 (by steam generation or process heat exchange) before entering the hot
2 hydrogen stripper/reactor 23. Stream 21 flows downwardly through a bed of
3 hydrotreating catalyst 52, while being contacted with countercurrent flowing
4 hydrogen from stream 32.

5
6 The overhead stream 26 from hot hydrogen stripper/reactor 23 contains
7 hydrogen, ammonia and hydrogen sulfide, along with light gases and
8 naphtha. It is cooled in exchanger 27. Water is injected (stream 36) into the
9 stream 26 to remove most of the ammonia as ammonium bisulfide solution
10 (ammonia and hydrogen sulfide react to form ammonium bisulfide which is
11 converted to solution by water injection). The stream is then air cooled by
12 cooler 45. The effluent from the air cooler enters the cold high pressure
13 separator 17. Hydrogen, light hydrocarbonaceous gases, and hydrogen
14 sulfide are removed overhead through stream 19. Hydrogen sulfide is
15 removed (stream 51) from the stream in the hydrogen sulfide absorber 20.
16 Ammonia and hydrogen sulfide is removed with the sour water stream
17 (stream 58) from the cold high pressure separator 17. Stream 40, which
18 contains hydrogen, is compressed in compressor 30 and splits into streams
19 29 and 31. Stream 31 is diverted from stream 29 for use as interstage
20 quench. Streams 4 and 5 are diverted from stream 31. Stream 29, containing
21 hydrogen, is combined with hydrogen stream 42 prior to combining with oil
22 feed stream 1.

23
24 Make-up hydrogen 38 is compressed and sent to four separate locations,
25 upstream of reactor 2 to combine with feed stream 1 (through stream 42), to
26 the hot high pressure separator 8 through stream 46, to the hot hydrogen
27 stripper/reactor 23, and to the middle distillate upgrader (stream 35) to
28 combine with recycle diesel or kerosene or to be used as interstage quench.
29 Stream 38, containing make-up hydrogen, passes to the make-up hydrogen
30 compressor 55. From stream 41, which exits compressor 55 containing
31 compressed hydrogen, streams 35, 42 and 46 are diverted.

32

1 In this embodiment, the middle distillate upgrading reactor 12 operates at
2 lower pressure than the first stage reactor 2. Liquid (stream 24) from the hot
3 hydrogen stripper 23 is reduced in pressure (via valve 28) and is combined
4 with make-up hydrogen (stream 35) after the second stage of compression of
5 the make-up hydrogen compressor 55. Recycle kerosene or diesel (stream
6 48) may be added at this point. The mixture is sent after preheat (in
7 exchanger 25) to the middle distillate upgrader 12, which is preferably loaded
8 with one or more beds of noble metal catalyst 13. Part of the make-up
9 hydrogen is available as quench (stream 47) between the beds for multiple
10 bed application. Reactor effluent (stream 14) is cooled in a series of heat
11 exchangers 15 and sent to a cold high pressure separator 59.

12

13 Overhead vapor 54 from the cold high pressure separator 59 is essentially
14 high-purity hydrogen with a small amount of hydrocarbonaceous light gases.
15 The vapor is sent to the make-up hydrogen compressor 55. Compressed
16 make-up hydrogen (stream 29) is sent to the high pressure reactor 2, the high
17 pressure separator 8, and hot hydrogen stripper/reactor 23. Bottoms (stream
18 18) from the cold high-pressure separator 17 is sent to the fractionation
19 section (stream 39) after pressure reduction.

20 Stream 14, which is the effluent from the middle distillate upgrader 12, is used
21 to heat the other process streams in the unit (see exchanger 15) and passes
22 to the cold high pressure separator 59. The liquid effluent of cold high
23 pressure separator 59, stream 37, passes to fractionation.

24

25 Feeds

26

27 A wide variety of hydrocarbon feeds may be used in the instant invention.
28 Typical feedstocks include any heavy or synthetic oil fraction or process
29 stream having a boiling point above 300°F (150°C). Such feedstocks include
30 vacuum gas oils, heavy atmospheric gas oil, delayed coker gas oil, visbreaker
31 gas oil, demetallized oils, vacuum residua, atmospheric residua, deasphalted
32 oil, Fischer-Tropsch streams, FCC streams, etc.

1 For the first reaction stage, typical feeds will be vacuum gas oil, heavy coker
2 gas oil or deasphalted oil. Lighter feeds such as straight run diesel, light cycle
3 oil, light coker gas oil or visbroken gas oil can be introduced upstream of the
4 hot hydrogen stripper/reactor 23.

5

6 Products

7

8 Figures 1 and 2 depict two different versions of the instant invention, directed
9 primarily to high quality middle distillate production as well as to production of
10 heavy hydrotreated gas oil.

11

12 The process of this invention is especially useful in the production of middle
13 distillate fractions boiling in the range of about 250°F-700°F (121°C-371°C). A
14 middle distillate fraction is defined as having a boiling range from about 250°F
15 to 700°F. At least 75 vol%, preferably 85 vol%, of the components of the
16 middle distillate have a normal boiling point of greater than 250°F. At least
17 about 75 vol%, preferably 85 vol%, of the components of the middle distillate
18 have a normal boiling point of less than 700°F. The term "middle distillate"
19 includes the diesel, jet fuel and kerosene boiling range fractions. The
20 kerosene or jet fuel boiling point range refers to the range between 280°F and
21 525°F (138°C-274°C). The term "diesel boiling range" refers to hydrocarbons
22 boiling in the range from 250°F to 700°F (121°C-371°C).

23

24 Gasoline or naphtha may also be produced in the process of this invention.
25 Gasoline or naphtha normally boils in the range below 400°F (204°C), or C₅-.
26 Boiling ranges of various product fractions recovered in any particular refinery
27 will vary with such factors as the characteristics of the crude oil source, local
28 refinery markets and product prices.

29

30 Heavy diesel, another product of this invention, usually boils in the range from
31 550°F to 750°F.

32

1 Conditions

2

3 Hydroprocessing conditions is a general term which refers primarily in this
4 application to hydrocracking or hydrotreating, preferably hydrocracking. The
5 first stage reactor, as depicted in Figures 1 and 2, may be either a VGO
6 hydrotreater or a moderate severity hydrocracker.

7

8 Hydrotreating conditions include a reaction temperature between 400°F-900°F
9 (204°C-482°C), preferably 650°F-850°F (343°C-454°C); a pressure from 500
10 to 5000 psig (pounds per square inch gauge) (3.5-34.6 MPa), preferably 1000
11 to 3000 psig (7.0-20.8 MPa); a feed rate (LHSV) of 0.5 hr⁻¹ to 20 hr⁻¹ (v/v); and
12 overall hydrogen consumption 300 to 5000 scf per barrel of liquid hydrocarbon
13 feed (53.4-356 m³/m³ feed).

14

15 In the embodiment shown in Figure 1, the first stage reactor and the middle
16 distillate upgrader are operating at the same pressure. In the embodiment
17 shown in Figure 2, the middle distillate upgrader is operating at a lower
18 pressure than the first stage reactor.

19

20 Typical hydrocracking conditions include a reaction temperature of from
21 400°F-950°F (204°C-510°C), preferably 650°F-850°F (343°C-454°C).
22 Reaction pressure ranges from 500 to 5000 psig (3.5-34.5 MPa), preferably
23 1500 to 3500 psig (10.4-24.2 MPa). LHSV ranges from 0.1 to 15 hr⁻¹ (v/v),
24 preferably 0.25-2.5 hr⁻¹. Hydrogen consumption ranges from 500 to 2500 scf
25 per barrel of liquid hydrocarbon feed (89.1-445 m³ H₂/m³ feed).

26

27 Catalyst

28

29 A hydroprocessing zone may contain only one catalyst, or several catalysts in
30 combination.

31

32 The hydrocracking catalyst generally comprises a cracking component, a
33 hydrogenation component and a binder. Such catalysts are well known in the

1 art. The cracking component may include an amorphous silica/alumina phase
2 and/or a zeolite, such as a Y-type or USY zeolite. Catalysts having high
3 cracking activity often employ REX, REY and USY zeolites. The binder is
4 generally silica or alumina. The hydrogenation component will be a Group VI,
5 Group VII, or Group VIII metal or oxides or sulfides thereof, preferably one or
6 more of molybdenum, tungsten, cobalt, or nickel, or the sulfides or oxides
7 thereof. If present in the catalyst, these hydrogenation components generally
8 make up from about 5% to about 40% by weight of the catalyst. Alternatively,
9 platinum group metals, especially platinum and/or palladium, may be present
10 as the hydrogenation component, either alone or in combination with the base
11 metal hydrogenation components molybdenum, tungsten, cobalt, or nickel. If
12 present, the platinum group metals will generally make up from about 0.1% to
13 about 2% by weight of the catalyst.

14

15 Hydrotreating catalyst, if used, will typically be a composite of a Group VI
16 metal or compound thereof, and a Group VIII metal or compound thereof
17 supported on a porous refractory base such as alumina. Examples of
18 hydrotreating catalysts are alumina supported cobalt-molybdenum, nickel
19 sulfide, nickel-tungsten, cobalt-tungsten and nickel-molybdenum. Typically,
20 such hydrotreating catalysts are presulfided.

21

1 Example

2

3

POST-HYDROTREATING OF MILD HYDROCRACKER

4

DISTILLATES FOR CETANE UPGRADING

Feed	Mild Hydrocracked Distillate from Vacuum Gas Oil/Coker Gas Oil Blend	Mild Hydrocracked Distillate from Middle Eastern Vacuum Gas Oil
Mild Hydrocracking Conversion	30 Liquid Volume % <680°F	31 Liquid Volume % <700°F
Hydrotreating Catalyst	Noble metal/Zeolite	Base metal/Alumina
Hydrotreating Conditions:		
Catalyst Bed Temperature, °F	594	720
LHSV, 1/hr	1.5	2.0
Gas/Oil Ratio, SCF/B	3000	5000
H ₂ Partial Pressure, psia	800	1900
Cetane Uplift (typical)	7 to 15	2 to 7

5

6 The Table above illustrates the effectiveness of upgrading the effluent of the
7 first stage reactor, which has been mildly hydrocracked. The effluent is
8 hydrotreated in the middle distillate upgrader. Cetane uplift (improvement) is
9 greater, and at less severe conditions, using a catalyst having a noble metal
10 hydrogenation component with a zeolite cracking component than when using
11 a catalyst having base metal hydrogenation components on alumina, an
12 amorphous support. Cetane uplift can be higher if external diesel range feeds
13 (7) are added upstream of Hot High Pressure Separator 44.

1 WHAT IS CLAIMED IS:
2

3 1. A method for hydroprocessing a hydrocarbon feedstock, said method
4 employing multiple hydroprocessing zones within a single reaction loop,
5 each zone having one or more catalyst beds, comprising the following
6 steps:

7

8 (a) passing a hydrocarbonaceous feedstock to a first
9 hydroprocessing zone having one or more beds containing
10 hydroprocessing catalyst, the hydroprocessing zone being
11 maintained at hydroprocessing conditions, wherein the
12 feedstock is contacted with catalyst and hydrogen;

13

14 (b) passing the effluent of step (a) directly to a hot high pressure
15 separator, wherein the effluent is contacted with a hot, hydrogen-
16 rich stripping gas to produce a vapor stream comprising hydrogen,
17 hydrocarbonaceous compounds boiling at a temperature below the
18 boiling range of the hydrocarbonaceous feedstock, hydrogen
19 sulfide and ammonia and a liquid stream comprising
20 hydrocarbonaceous compounds boiling approximately in the range
21 of said hydrocarbonaceous feedstock;

22

23 (c) passing the vapor stream of step (b) after cooling and partial
24 condensation, to a hot hydrogen stripper containing at least one
25 bed of hydrotreating catalyst, where it is contacted countercurrently
26 with hydrogen, while the liquid stream of step (b) is passed to
27 fractionation;

28

29 (d) passing an overhead vapor stream from the hot hydrogen
30 stripper/reactor of step (c), after cooling and contact with water,
31 the overhead vapor stream comprising hydrogen, ammonia, and
32 hydrogen sulfide, along with light gases and naphtha to a cold

- 1 high pressure separator, where hydrogen, hydrogen sulfide, and
2 light hydrocarbonaceous gases are removed overhead, ammonia
3 is removed from the cold high pressure separator as ammonium
4 bisulfide in a sour water stripper, and naphtha and middle distillates
5 are passed to fractionation;
6
- 7 (e) passing the liquid stream from the hot hydrogen stripper/reactor
8 of step (c) to a second hydroprocessing zone, the second
9 hydroprocessing zone containing at least one bed of
10 hydroprocessing catalyst suitable for aromatic saturation and
11 ring opening, wherein the liquid is contacted under
12 hydroprocessing conditions with the hydroprocessing catalyst, in
13 the presence of hydrogen;
14
- 15 (f) passing the overhead from the cold high pressure separator of
16 step (d) to an absorber, where hydrogen sulfide is removed
17 before hydrogen is compressed and recycled to
18 hydroprocessing vessels within the loop; and
19
- 20 (g) passing an effluent of step (e) to the cold high pressure
21 separator of step (d).
22
- 23 2. The process of claim 1, wherein the hydroprocessing conditions of step
24 1(a) comprise a reaction temperature of from 400°F-950°F, a reaction
25 pressure in the range from 500 to 5000 psig, an LHSV in the range from
26 0.1 to 15 hr⁻¹ (v/v), and hydrogen consumption in the range from 500 to
27 2500 scf per barrel of liquid hydrocarbon feed.
28
- 29 3. The process of claim 2, wherein the hydroprocessing conditions of
30 step 1(a) comprise a temperature in the range from 650°F-850°F,
31 reaction pressure in the range from 1500-3500 psig, and an LHSV in the
32 range from 0.25 to 2.5 hr⁻¹ (v/v).

- 1
- 2 4. The process of claim 1, wherein the hydroprocessing conditions of step
- 3 1(e) comprise a reaction temperature of from 400°F-950°F, a reaction
- 4 pressure in the range from 500 to 5000 psig, an LHSV in the range from
- 5 0.1 to 15 hr⁻¹ (v/v), and hydrogen consumption in the range from 500 to
- 6 2500 scf per barrel of liquid hydrocarbon feed.
- 7
- 8 5. The process of claim 4, wherein the hydroprocessing conditions of step
- 9 1(e) comprise a temperature in the range from 650°F-850°F, reaction
- 10 pressure in the range from 1500-3500 psig, and an LHSV in the range
- 11 from 0.25 to 2.5 hr⁻¹ (v/v).
- 12
- 13 6. The process of claim 1, wherein the feed to step 1(a) comprises
- 14 hydrocarbons boiling in the range from 500°F to 1500°F.
- 15
- 16 7. The process of claim 1, wherein the feed is selected from the group
- 17 consisting of vacuum gas oil, heavy atmospheric gas oil, delayed coker
- 18 gas oil, visbreaker gas oil, FCC light cycle oil, and deasphalted oil.
- 19
- 20 8. The process of claim 1, wherein the cetane number improvement
- 21 occurring in step 1(e) ranges from 2 to 15.
- 22
- 23 9. The process of claim 1, wherein the hydroprocessing catalyst comprises
- 24 both a cracking component and a hydrogenation component.
- 25
- 26 10. The process of claim 9, wherein the hydrogenation component is selected
- 27 from the group consisting of Ni, Mo, W, Pt and Pd or combinations
- 28 thereof.
- 29
- 30 11. The process of claim 9, wherein the cracking component is amorphous or
- 31 zeolitic.
- 32

- 1 12. The process of claim 11, wherein the zeolitic component is selected from
2 the group consisting of Y, USY, REX, and REY zeolites.
3
- 4 13. The process of claim 1, wherein the second hydroprocessing zone of step
5 1(e) is maintained at the same pressure as the first hydroprocessing zone
6 of step 1(a).
7
- 8 14. The process of claim 1, wherein the second hydroprocessing zone of step
9 1(e) is maintained at a lower pressure than that of the first
10 hydroprocessing zone of step 1(a).
11
- 12 15. The process of claim 14, wherein the second hydroprocessing zone of
13 step 1(e) is maintained at a pressure that is from 500 to 1500 psi lower
14 than the pressure in the first hydroprocessing zone.

FIGURE 1

