

(No Model.)

A. T. ROUSSEAU.
PIANO FORTE ACTION.

No. 445,905.

Patented Feb. 3, 1891.

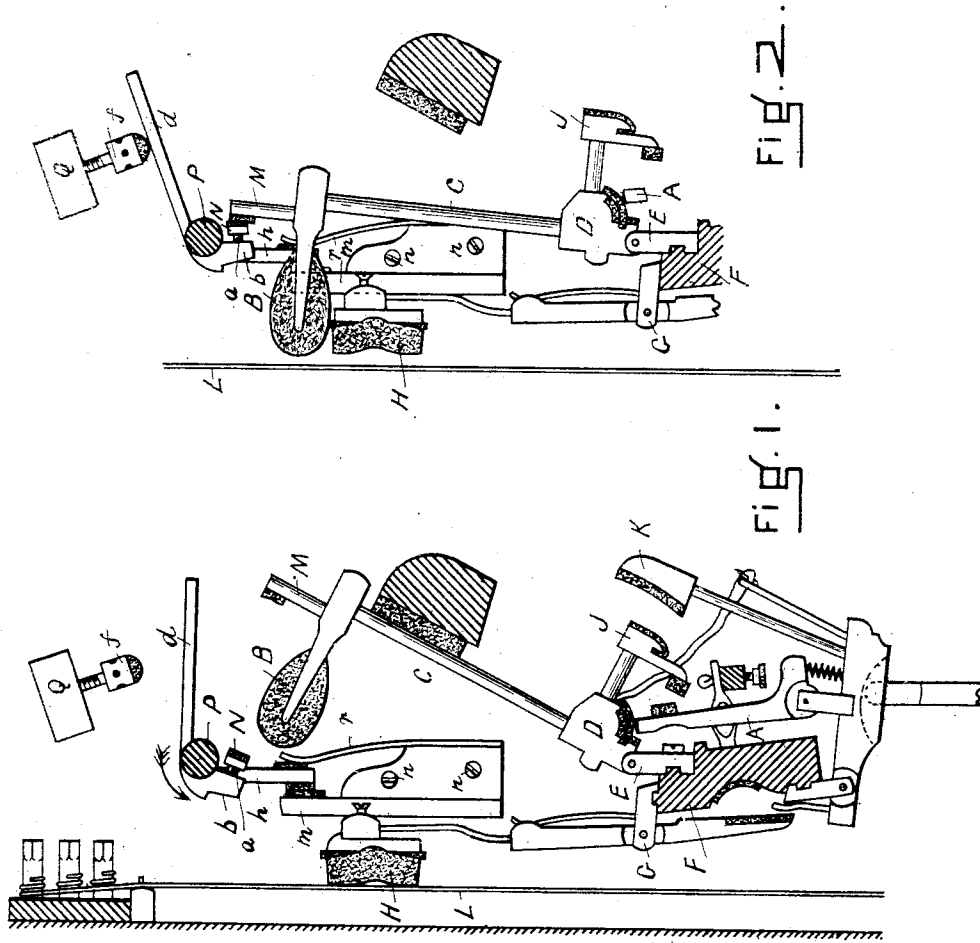

WITNESSES.
Barrie C. Nichols.
Geo. E. Fowle Jr

INVENTOR
A. T. Rousseau.
Per Edwin W. Brown.
Attorney.

UNITED STATES PATENT OFFICE.

AUGUSTE THEOPHILE ROUSSEAU, OF CAMBRIDGE, MASSACHUSETTS.

PIANO-FORTE ACTION.

SPECIFICATION forming part of Letters Patent No. 445,905, dated February 3, 1891.

Application filed January 19, 1889. Serial No. 296,866. (No model.)

To all whom it may concern:

Be it known that I, AUGUSTE THEOPHILE ROUSSEAU, of Cambridge, in the county of Middlesex and State of Massachusetts, have
5 invented certain new and useful Improvements in Piano-Forte Actions, of which the following is a full, clear, and exact description.

This invention relates to means for producing the soft stop in a piano-forte, and to those
10 by which the force of the blow of the piano-forte-action hammer is controlled to produce as soft or as light a blow on the string as desired, and to those that do not affect the touch of the action; and the invention consists of certain constructions and arrangements of parts,
15 in combination with the hammer of a piano-forte action, by which the force of the blow of the hammer upon the string is controlled and regulated, all substantially as hereinafter fully described, reference being had to the
20 accompanying sheet of drawings, in which the figures represent in side views the portion of an upright-piano-forte action above the key and as having my invention applied thereto.
25

Figure 1 represents the parts in their normal positions, and Fig. 2 shows some of the parts in different positions to be hereinafter referred to.

30 In the drawings, A is the jack; B, the hammer; C, its stem, pivoted by its butt D to the flange E, secured to the cross-rail F, to which is also secured by the flange G the damper H.

J is the heel of the hammer-butt, K the
35 back-catch, and L the string, all constructed and arranged for operation as usual in upright-piano-forte actions and needing no more particular description herein.

The hammer B has an upwardly-projecting
40 stem or arm M, and N is a button on the end of a screw rod or wire *a*, screwing into a downwardly-projecting arm *b* of a cross rail or rod P, adapted to turn or rock on pivots in the end uprights (not shown) of the action-frame. The rail P has an arm *d*, preferably
45 at or near one end, which is connected to a pedal of the piano-forte in any suitable manner for operation thereof, and when it is moved upward swings the rail P on its pivots in the
50 direction of the arrow, Fig. 1, the arm *d* abutting against the screw-head *f* of a cross rail or stop Q, limiting the upward movement or

swing of the rail P, the length of its movement being regulated by the turning in or out of the screw *f*. The rail P also has a
55 downwardly-projecting arm *h*, preferably at or near one end, which abuts against a stop *m*, secured by screws *n* to the end upright of the action or to any suitable support to limit the downward swing of the rail, a flat
60 spring *r*, secured to the stop and bearing by its free end against the arm *h*, also holding the arm against the stop and acting to return the rail to its normal position when moved therefrom.
65

The operation of the device is as follows: When desirous of producing the soft tones, the rail P is swung in the direction of the arrow by pressing upward its arm *d* by the pedal or otherwise, which brings its button N into
70 the position shown in Fig. 2, and if then the piano-key is operated for the hammer to strike the string the projecting stem or arm M of the hammer will abut or strike against the button just at the time or a little before the
75 hammer strikes the string, or as desired, which stops the hammer from further movement against the string, and consequently giving a light blow on the string, which blow is regulated by turning in or out the button N. As
80 the force with which the hammer strikes the string can be controlled and regulated by the regulating-button N, with this invention applied to all the hammers of the action they can be all so regulated that they will strike
85 with equal force, and thus produce an even and regular soft tone throughout the instrument.

By this invention the force of the blow of the hammer is regulated, as desired, and
90 without affecting the operation of the other parts of the action, the "touch" of the action being preserved at all times.

Having thus described my invention, what I claim is—
95

1. The combination, with a hammer of a piano-forte action, of a stop or abutment adjustable in itself and independently of the stops or abutments of the other hammers and attached to a suitable support, which support
100 is constructed and arranged to move the stop or abutment into position for the hammer to abut against it, for the purpose specified.

2. The combination, with a hammer of a

piano-forte action, provided with a projecting stem or arm from its upper side, of a stop or abutment constructed and arranged to be moved into position for said projecting stem or arm to abut against it, for the purpose specified.

3. The combination, with the hammer of a piano-forte action, provided with a projecting stem or arm, of an adjustable stop or abutment constructed and arranged to be moved into position for said projecting stem or arm to abut against the same, for the purpose specified.

4. The combination, with the hammer of a piano-forte action, provided with a projecting stem or arm, of a rail P, adapted to be swung on its pivots by the pedal of the piano-forte and having an arm *b* and screw-button N, for the purpose specified.

In testimony whereof I have hereunto set my hand in the presence of two subscribing witnesses.

AUGUSTE THEOPHILE ROUSSEAU.

Witnesses:

EDWIN W. BROWN,
GEORGE A. ROUSSEAU.