



(51) International Patent Classification:  
*H04S 3/00* (2006.01) *H04N 21/439* (2011.01)  
*H04R 5/02* (2006.01)

(21) International Application Number:  
PCT/KR2013/001128

(22) International Filing Date:  
13 February 2013 (13.02.2013)

(25) Filing Language: English

(26) Publication Language: English

(30) Priority Data:  
61/599,154 15 February 2012 (15.02.2012) US  
61/602,975 24 February 2012 (24.02.2012) US  
61/602,978 24 February 2012 (24.02.2012) US  
61/604,844 29 February 2012 (29.02.2012) US  
61/604,892 29 February 2012 (29.02.2012) US  
61/611,822 16 March 2012 (16.03.2012) US  
61/613,629 21 March 2012 (21.03.2012) US  
61/636,879 23 April 2012 (23.04.2012) US  
61/636,901 23 April 2012 (23.04.2012) US  
61/641,580 2 May 2012 (02.05.2012) US  
61/647,628 16 May 2012 (16.05.2012) US  
10-2012-0123642 2 November 2012 (02.11.2012) KR

(71) Applicant: SAMSUNG ELECTRONICS CO., LTD.  
[KR/KR]; 129, Samsung-ro, Yeongtong-gu, Suwon-si,  
Gyeonggi-do 443-742 (KR).

(72) Inventors: KIM, Jong-hwa; 172-13, Godeung-dong,  
Paldal-gu, Suwon-si, Gyeonggi-do 442-882 (KR). KIM,  
Soo-young; No. 204, Yeji Villat, 1250-4, Maetan 3(sam)-  
dong, Yeongtong-gu, Suwon-si, Gyeonggi-do 443-848  
(KR). NA, Il-ju; 101-306, Jukjeon Xi 2-cha Apt., Bojeong-  
dong, Giheung-gu, Yongin-si, Gyeonggi-do 446-913 (KR).

Yun, Suk-jin; 2-204, Jinheung Apt., Seocho 4(sa)-dong,  
Seocho-gu, Seoul 137-776 (KR). LEE, Jae-min; 113-  
1701, Raemian Nobleclass Apt., Ingye-dong, Paldal-gu,  
Suwon-si, Gyeonggi-do 442-703 (KR). LEE, Kyeong-jae;  
308-203, III-Zium Apt., Jamsil 3(sam)-dong, Songpa-gu,  
Seoul 138-890 (KR).

(74) Agent: JEONG, Hong-sik; 8th Floor, Daelim Bldg., 1600-  
3, Seocho-dong, Seocho-gu, Seoul 137-877 (KR).

(81) Designated States (unless otherwise indicated, for every  
kind of national protection available): AE, AG, AL, AM,  
AO, AT, AU, AZ, BA, BB, BG, BH, BN, BR, BW, BY,  
BZ, CA, CH, CL, CN, CO, CR, CU, CZ, DE, DK, DM,  
DO, DZ, EC, EE, EG, ES, FI, GB, GD, GE, GH, GM, GT,  
HN, HR, HU, ID, IL, IN, IS, JP, KE, KG, KM, KN, KP,  
KZ, LA, LC, LK, LR, LS, LT, LU, LY, MA, MD, ME,  
MG, MK, MN, MW, MX, MY, MZ, NA, NG, NI, NO, NZ,  
OM, PA, PE, PG, PH, PL, PT, QA, RO, RS, RU, RW, SC,  
SD, SE, SG, SK, SL, SM, ST, SV, SY, TH, TJ, TM, TN,  
TR, TT, TZ, UA, UG, US, UZ, VC, VN, ZA, ZM, ZW.

(84) Designated States (unless otherwise indicated, for every  
kind of regional protection available): ARIPO (BW, GH,  
GM, KE, LR, LS, MW, MZ, NA, RW, SD, SL, SZ, TZ,  
UG, ZM, ZW), Eurasian (AM, AZ, BY, KG, KZ, RU, TJ,  
TM), European (AL, AT, BE, BG, CH, CY, CZ, DE, DK,  
EE, ES, FI, FR, GB, GR, HR, HU, IE, IS, IT, LT, LU, LV,  
MC, MK, MT, NL, NO, PL, PT, RO, RS, SE, SI, SK, SM,  
TR), OAPI (BF, BJ, CF, CG, CI, CM, GA, GN, GQ, GW,  
ML, MR, NE, SN, TD, TG).

Published:  
— with international search report (Art. 21(3))

(54) Title: DATA TRANSMITTING APPARATUS, DATA RECEIVING APPARATUS, DATA TRANSRECEIVING SYSTEM,  
DATA TRANSMITTING METHOD, DATA RECEIVING METHOD AND DATA TRANSRECEIVING METHOD

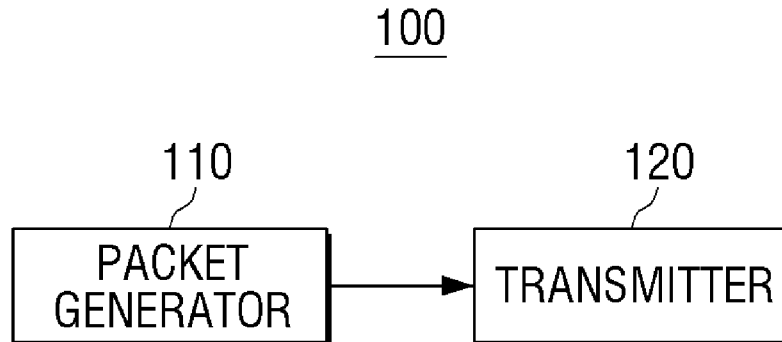

(57) Abstract: A data transmitting apparatus is provided. The data transmitting apparatus includes a packet generator configured to generate a packet including a plurality of sub packets and a transmitter configured to transmit the generated packet to a data receiving apparatus. Each of the plurality of sub packets includes audio data corresponding to content among a plurality of contents.

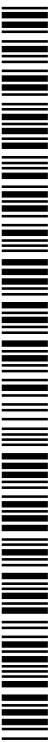

## Description

### **Title of Invention: DATA TRANSMITTING APPARATUS, DATA RECEIVING APPARATUS, DATA TRANSRECEIVING SYSTEM, DATA TRANSMITTING METHOD, DATA RECEIVING METHOD AND DATA TRANSRECEIVING METHOD**

#### **Technical Field**

- [1] Apparatuses and methods consistent with exemplary embodiments relate to a data transreceiving apparatus and method, and more particularly, to a data transmitting apparatus, a data receiving apparatus, a data transreceiving system, a data transmitting method, a data receiving method, and a data transreceiving method, which transmit multichannel audio signals in wired interface environments.

#### **Background Art**

- [2] Recently, as multimedia environments have been implemented, wired interface environments for various types of data transmission have been proposed. For example, high-definition multimedia interface (HDMI) and mobile high definition link (MHL) prescribe transmission standards for various formats of image data, audio signals, and control signals. In particular, with the development of multiview environments in which a plurality of contents are displayed on one screen and a plurality of users can watch contents which are different from each other, multicontent (multistream) audio signal transmission standards for transreceiving sound for each type of content are needed. Various formats and device environments used in the related art have to be considered in the transmission of the multichannel audio signals.

#### **Disclosure of Invention**

##### **Technical Problem**

- [3] One or more exemplary embodiments provide a data transmitting apparatus, a data receiving apparatus, a data transreceiving system, a data transmitting method, a data receiving method, and a data transreceiving method, which transmit multistream (multicontent) audio signals.

##### **Solution to Problem**

- [4] One or more exemplary embodiments may overcome the above disadvantages and other disadvantages not described above. However, it is understood that one or more exemplary embodiment are not required to overcome the disadvantages described above, and may not overcome any of the problems described above.
- [5] According to an aspect of an exemplary embodiment, there is provided a data

transmitting apparatus. The data transmitting apparatus may include: a packet generator configured to generate a packet including a plurality of sub packets; and a transmitter configured to transmit the generated packet to a data receiving apparatus. Each of the plurality of sub packets may include audio data corresponding to content among a plurality of contents.

- [6] Each of the plurality of sub packets may further include an identification field which represents whether the corresponding sub packet indicates content among the plurality of contents.
- [7] The generated packet may include a header and the header may include one of a stream present bit indicating whether or not each of the plurality of sub packets includes the audio data and a stream flat bit indicating whether or not the audio data included in each of the plurality of sub packets is effective data.
- [8] Each of the plurality of sub packets may store a portion of the audio data.
- [9] The audio data may include audio signals of two channels or more.
- [10] The audio data may comply with an international electrotechnical commission (IEC) 60958 format.
- [11] According to another aspect of an exemplary embodiment, there is provided a data receiving apparatus. The data receiving apparatus may include: a receiver configured to receive a packet including a plurality of sub packets; and a packet parsing unit configured to perform parsing on the received packet. Each of the plurality of sub packets may include audio data corresponding to content among a plurality of contents.
- [12] The received packet may include a header and the header may include one of a stream present bit indicating whether or not each of the plurality of sub packets includes the audio data and a stream flat bit indicating whether or not the audio data included in each of the plurality of sub packets is effective data.
- [13] Each of the plurality of sub packets may store a portion of the audio data.
- [14] The audio data may include audio signals of two channels or more.
- [15] The audio data may comply with an IEC 60958 format.
- [16] According to another aspect of an exemplary embodiment, there is provided a data transreceiving system. The data transreceiving system may include: a data transmitting apparatus configured to generate a packet including a plurality of sub packets and transmit the generated packet; and a data receiving apparatus configured to receive the transmitted packet and perform parsing on the received packet. Each of the plurality of sub packets may include audio data corresponding to content among a plurality of contents.
- [17] According to another aspect of an exemplary embodiment, there is provided a data transmitting method. The data transmitting method may include generating a packet including a plurality of sub packets; and transmitting the generated packet to a data

receiving apparatus. Each of the plurality of sub packets may include audio data corresponding to content among a plurality of contents.

[18] Each of the plurality of sub packets may further include an identification field which represents whether the corresponding sub packet indicates content among the plurality of contents.

[19] The generated packet may include a header and the header may include one of a stream present bit indicating whether or not each of the plurality of sub packets includes the audio data and a stream flat bit indicating whether or not the audio data included in each of the plurality of sub packets is effective data.

[20] Each of the plurality of sub packets may store a portion of the audio data.

[21] According to another aspect of an exemplary embodiment, there is provided a data receiving method. The data receiving method may include: receiving a packet including a plurality of sub packets; and performing parsing on the received packet. Each of the plurality of sub packets may include audio data corresponding to content among a plurality of contents.

[22] The received packet may include a header and the header may include any one of a stream present bit indicating whether or not each of the plurality of sub packets includes the audio data and a stream flat bit indicating whether or not the audio data included in each of the plurality of sub packets is effective data.

[23] Each of the plurality of sub packets may store a portion of the audio data.

[24] The audio data may include audio signals of two channels or more.

[25] According to another aspect of an exemplary embodiment, there is provided a data transreceiving method. The data transreceiving method may include: transmitting an extended display identification data (EDID) block including at least one of a first sub block indicating three-dimensional (3D) audio characteristics of multichannel audio data and a second sub block indicating 3D speak allocation information of the multichannel audio data from a first apparatus to a second apparatus; transmitting a meta data packet including at least one of an ACAT field indicating channel allocation standard type information of the multichannel audio data, a channel count field indicating the number of channels of the multichannel audio data, and a 3D channel/speaker allocation field indicating channel/speaker allocation information of the multichannel audio data from the second apparatus to the first apparatus; transmitting at least one multichannel audio sample data packet from the second apparatus to the first apparatus; and performing parsing on the transmitted at least one multichannel audio sample data packet to output audio in the first apparatus. The at least one multichannel audio sample data packet may include a plurality of sub packets and each of the plurality of sub packets includes an identification field for identifying a position or an order thereof among the plurality of sub packets.

- [26] According to another aspect of an exemplary embodiment, there is provided a data transreceiving method. The data transreceiving method may include: transmitting an EDID block including a sub block indicating multistream audio characteristics of multichannel audio data from a first apparatus to a second apparatus; transmitting an audio infoframe packet including at least one of a channel count field indicating the number of channels of the multichannel audio data and a 3D channel/speaker allocation field indicating channel/speaker allocation information of the multichannel audio data from the second apparatus to the first apparatus; transmitting at least one audio sample data packet from the second apparatus to the first apparatus; and performing parsing on the transmitted at least one audio sample data packet to output audio in the first apparatus. The at least one audio sample data packet may include a plurality of sub packets and each of the plurality of sub packets may include audio data corresponding to content among a plurality of contents.
- [27] According to the above-described various exemplary embodiments, a packet including a plurality of sub packets is generated and each of the plurality of sub packets includes audio data corresponding to content among a plurality of contents so that standards, which are capable of transmitting audio signals for the plurality of contents as one packet, are provided.
- [28] Additional aspects and advantages of the exemplary embodiments will be set forth in the detailed description, will be obvious from the detailed description, or may be learned by practicing the exemplary embodiments.

### **Advantageous Effects of Invention**

[29] -

### **Brief Description of Drawings**

- [30] The above and/or other aspects will be more apparent by describing in detail exemplary embodiments, with reference to the accompanying drawings, in which:
- [31] FIG. 1 is a view illustrating a transmission timing of a 3D audio signal;
- [32] FIG. 2 is a block diagram illustrating a configuration of a data transreceiving system according to an exemplary embodiment;
- [33] FIG. 3 is a block diagram illustrating a configuration of a data transmitting apparatus of the data transreceiving system of FIG. 2;
- [34] FIG. 4 is a block diagram illustrating a configuration of a data receiving apparatus of the data transreceiving system of FIG. 2;
- [35] FIG. 5 is a view representing a transmission stream of an audio sample packet according to an exemplary embodiment;
- [36] FIG. 6 is a view representing a transmission stream of an audio sample packet according to another exemplary embodiment;

- [37] FIG. 7 is a view illustrating a transmission stream format according to an exemplary embodiment;
- [38] FIG. 8 is a view representing a transmission stream of an audio sample packet according to an exemplary embodiment;
- [39] FIGS. 9 and 10 are views representing transmission streams of multistream audio sample packets according to an exemplary embodiment;
- [40] FIG. 11 is a view representing a transmission stream of a multistream audio sample packet according to an exemplary embodiment;
- [41] FIG. 12 is a schematic diagram showing transmission of speaker position information using consumer electronic control (CEC) according to an exemplary embodiment;
- [42] FIG. 13 is a view illustrating a sequence of transmitting a 3D audio sample from a blu-ray disc player (BDP) to a television (TV) according to an exemplary embodiment;
- [43] FIG. 14 is a view illustrating a sequence of transmitting multistream audio from a BDP to a TV according to an exemplary embodiment;
- [44] FIG. 15 is a view illustrating a speaker arrangement for a channel of 3D audio according to an exemplary embodiment; and
- [45] FIGS. 16 to 19 are flowcharts illustrating data transmitting methods and data receiving methods according to various exemplary embodiments.

### **Best Mode for Carrying out the Invention**

- [46] Certain exemplary embodiments will now be described in greater detail with reference to the accompanying drawings.
- [47] In the following description, the same drawing reference numerals are used for the same elements even in different drawings. The matters defined in the description, such as a detailed construction and elements, are provided to assist in a comprehensive understanding of the exemplary embodiments. Accordingly, it is apparent that the exemplary embodiments can be carried out without those specifically defined matters. Also, well-known functions or constructions are not described in detail since they would obscure the exemplary embodiments with unnecessary detail.
- [48] The term ‘multi-channel audio’ as used herein indicates audio signals having more than 2 channels. In the following description of the exemplary embodiments, the multi-channel audio is divided into 2-dimensional (2D) audio channels and 3-dimensional (3D) audio channels. The ‘2D audio channels’ have a plurality of audio channels from 2 channels to 8 channels, and indicate audio channels in which speakers corresponding to the respective channels are placed on a plane. In contrast, the ‘3D audio channels’ have a plurality of audio channels including more than 9 channels, and speakers corresponding to the respective channels are placed on a 3D space.
- [49] For instance, exemplary embodiments may implement the 3D audio use channel

layout defined in TTA (10.2ch), SMPTE2036-2 (22.2ch) or IEC62574 (30.2ch). The 3D audio may include down mix audio streams as is defined herein.

[50] The term 'multi-stream audio' indicates audio signals having audio signals classified corresponding to each view in a multi-view environment in which two or more distinguishing contents are viewable. Audio signals of each view may be multi channel audio. For example, the multi-stream audio may be a class of audio streams related to video streams transmitted using a 3D video format, if a multi-view video, such as those associated with dual view games or quad view games, is supported.

[51] In the following, the exemplary embodiments will be explained based on 3D audio having from 9 to 32 channels (or more), which is extended from the audio of the HDMI 1.4b specification, and multi-stream audio for multi-view display apparatuses. More importantly, alterations to be described below are included to support the new audio features.

[52] However, because exemplary embodiments may be applied to transmitting standards of various wiry interfaces, such as the Mobile High-Definition Link (MHL) standard as well as the High-Definition Multimedia Interface (HDMI) standard within an equivalent scope of the technical art, the exemplary embodiments to be described below may be effective in similar wiry interface transmitting standards.

[53] In the following description, a new definition of HDMI packets transmitted through a data island period (including 3D Audio Sample Packets, 3D One Bit Audio Sample Packets, Audio Metadata Packets, Multi-Stream Audio Sample Packets and Multi-Stream One Bit Audio Sample Packets), a packetization process for the packets, and a definition of HDMI audio data blocks within Extended Display Identification Data (E-EDID) to support discovering functions according to new features will be described. Unless otherwise defined herein, according to exemplary embodiments, the specifications are basically according to HDMI 1.4b and not altered from HDMI 1.4b.

[54] Explanations contrary to HDMI 1.4b may be replaced with newly defined features mentioned below, however, other explanations may be consistent with the specification of HDMI 1.4b. The specification refers to the followings.

[55] HDMI, HDMI Licensing, LLC, High-Definition Multimedia Interface Specification Version 1.4b, October 11, 2011

[56] TTA, TTAK.KO-07.0098, Audio Signal Formats for Ultra High Definition (UHD) Digital TV, December 21, 2011

[57] SMPTE, SMPTE 2036-2:2008, UHDTV Audio characteristics and audio channel mapping for program production, 2008

[58] IEC, IEC 62574 ed. 1.0, Audio, video and multimedia systems General channel assignment of multichannel audio, April 7, 2011

[59] MHL, LLC, Mobile High-definition Link version 2.0, February, 2012

[60] \*TTA: Telecommunications Technology Association

[61] Overview

[62] Basic audio functions include a function related to a linear pulse-code modulation (L-PCM) audio stream of IEC 60958 in which the sample rate is 32 kHz, 44.1 kHz, or 48 kHz. This audio stream may contain a normal stereo stream. Optionally, HDMI may transmit audio having from 3 to 32 audio channels at the sample rate of 192 kHz. The HDMI may transmit audio streams in the IEC 61937 compression format having a bit rate reaching 49.152 Mbps (e.g., surround sound). HDMI may transmit one bit audio having from 2 to 32 audio channels and Direct Stream Transfer (DST), i.e., one bit audio in compression format. HDMI may transmit a 3D audio stream in which the speaker can be placed anywhere in 3D space. The 3D audio stream may include 32 audio channels at maximum, which are transmitted in a data island period through consecutive packets. HDMI may transmit a plurality of audio streams, if multi-view video streaming (for instance, dual view games or quad view games having a plurality of audio in each view) is supported. Regarding this case, four stereo audio streams may be supported.

[63] Data Island Packet Definition

[64] In section 5.3.1 packet header of the HDMI 1.4b specification, Tables 5-8 may be replaced with the following tables.

[65] Table 1 - Packet Types

[66]

Packet Type Value	Packet Type	Described in Section
0x00	Null	5.3.2
0x01	Audio Clock Regeneration (N/CTS)	5.3.3
0x02	Audio Sample(L-PCM and IEC 61937 compressed formats)	5.3.4
0x03	General Control	5.3.6
0x04	ACP Packet	5.3.7
0x05	ISRC1 Packet	5.3.8
0x06	ISRC2 Packet	"
0x07	One Bit Audio Sample Packet	5.3.9
0x08	DST Audio Packet	5.3.10
0x09	High Bitrate(HBR) Audio Stream Packet (IEC 61937)	5.3.11
0x0A	Gamut Metadata Packet	5.3.12
0x0B	3D Audio Sample Packet	5.3.13
0x0C	3D One Bit Audio Sample Packet	5.3.14
0x0D	Audio Metadata Packet	5.3.15
0x0E	Multi-Stream Audio Sample Packet	5.3.16
0x0F	Multi-Stream One Bit Audio Sample Packet	5.3.17
0x80+InfoFrame Type	InfoFrame Packet	5.3.5
	0x81 Vendor-Specific InfoFrame	8.2.3
	0x82 AVI InfoFrame	8.2.1
	0x83 Source Product Descriptor InfoFrame	-
	0x84 Audio InfoFrame	8.2.2
	0x85 MPEG Source InfoFrame	-

[67] \* For packet layout for the InfoFrames, section 8.2 of the HDMI 1.4b specification should be referred to.

[68] Referring to Table 1, new packets are defined from areas 0x0B to 0x0F. In 0x0B, a 3D Audio Sample Packet is defined. In 0x0C, a 3D One bit Audio Sample Packet is defined. Further, an Audio Meta Data Packet is defined in 0x0D, a Multi-Stream Audio Sample Packet is defined in 0x0E, and a Multi-Stream One bit Audio Sample Packet is defined in 0x0F. Newly defined packets will be explained in detail below.

[69] Further, various alternative suggestions that do not newly define packets will be also explained. The packet definitions of Table 1 will be referred to as a first exemplary embodiment. Various alternative suggestions will be referred to as a second exemplary embodiment, a third exemplary embodiment, and so on. Various alternative suggestions will be explained based on differences from the first exemplary embodiment.

[70] 1-1. 3D Audio Sample Packet

[71] First Exemplary Embodiment

[72] In a first exemplary embodiment, 3D audio in an L-PCM format may be transmitted using newly defined 3D audio sample packets. As described above, the ‘3D audio’ is defined as the audio in which speakers can be placed on a determined position according to a 3D audio standard (e.g., 10.2ch, 22.2ch, 30.2ch, or more) in 3D space.

[73] A 3D audio stream may include 32 audio channels (or more) and be transmitted in a data island period through consecutive packets. Each packet may have up to 8 audio channels. A packet header may include sample-start and sample-present bits to inform (indicate) the packet position within a 3D audio sample, which will be described below. The following table represents a 3D audio sample packet header.

[74] Table 2 - 3D Audio Sample Packet Header

[75]

Byte/Bit #	7	6	5	4	3	2	1	0
HB0	0	0	0	0	1	0	1	1
HB1	Rsvd (0)	Rsvd (0)	Rsvd (0)	sample_start	sample_present sp3	sample_present sp2	sample_present sp1	sample_present sp0
HB2	B3	B2	B1	B0	sample_flat sp3	sample_flat sp2	sample_flat sp1	sample_flat sp0

[76]

[77] Each field includes the following information.

[78] sample\_start: [1 bit] indicates that, if sample-start is 1, a current packet is a first packet of a 3D audio sample. Thus, sample\_start indicates the beginning of a 3D audio stream. Sink distinguishes a starting part of a sample from sample-start.

[79] sample\_start=1 indicates that a current 3D audio sample packet is fully packetized to 8 audio channels, in addition to indicating that the current 3D audio sample packet is a first packet of 3D audio samples. However, if 3D audio down-mixed lower than 8 audio channels is transmitted, only 8 audio channels or less can be packetized. sample\_start=0 indicates that a current 3D audio sample packet is a middle or last packet of 3D audio samples, and includes 8 audio channels or less. Setting of five

effective sample\_present bits of a 3D audio sample packet may only be present.

[80] sample\_present.spX: [4 fields, 1 bit each] indicates whether a sub packet X includes an audio sample. One piece of 3D audio sample data may be included in two 3D audio sample packets or more, and each 3D audio sample packet may have four sub packets. Thus, each 3D audio sample packet header may have four sample-present bits in total corresponding to the four sub packets. Each sample\_present bit indicates whether a corresponding sub packet has a part of a 3D audio sample.

[81] sample\_flat.spX: [4 fields, 1 bit each] indicates whether a sub packet X refers to a flatline sample or not. It is valid if sample\_present.spX is established. If available audio data that can be used at sources is not found, four sample\_flat.spX bit may be established. The establishing may occur when a sample rate changes or when temporary stream interruptions exist. If sample\_flat.spX is established, the sub packet X still refers to a sample period, however, does not include available audio data.

sample\_flat.spX is valid only if a corresponding sample\_present.spX bit is established.

[82] Adjacent 3D audio sample packets may be utilized in transmitting one 3D audio sample having from 9 to 32 channels of L-PCM audio (i.e., frames are 5 to 16 IEC 60958 frames).

[83] Table 3 presents valid sample\_present bit values.

[84] Table 3 - Valid Sample\_Present Bit Configurations for 3D Audio Transmission

[85]

SP0	SP1	SP1	SP3	Description
0	0	0	0	No Subpackets contain parts of the audio sample
1	0	0	0	Only Subpacket 0 contains one part of the audio sample
1	1	0	0	Subpackets 0 and 1 contain two contiguous parts of the audio sample
1	1	1	0	Subpackets 0, 1 and 2 contain three contiguous parts of the audio sample
1	1	1	1	Subpackets 0, 1 and 3 contain four contiguous parts of the audio sample

[86] B.X: [4 fields, 1 bit each] indicates that if a sub packet X includes a first frame in 192 frames consisting of an IEC 60958 block, B.X=1. Otherwise, B.X=0.

[87] 3D audio sample packets include an audio sample packet header as shown in Table 2 and four sub packets. Each sub packet of 3D audio sample packets has 3D audio sample data defined according to IEC 60958.

[88] If sources request a down mix of a 3D audio stream, a down-mixed audio stream may be transmitted using 3D audio sample packets. If Sink does not support 3D audio, sources may not transmit a 3D audio sample packet. Converting 3D audio to legacy audio format may be out of the scope of this specification. Based on channel numbers, numerous sub packet layouts which are different from each other may exist. In the following, Tables 4 to 6 indicate examples of 3D audio packet layouts for 12, 24, and

32 channels, respectively.

[89] Table 4 - Example of 3D Audio Sample Packet Layout for 12 channels

[90]

Packet #	sample_start Value	Num Channels	Samples	Subpkt 0	Subpkt 1	Subpkt 2	Subpkt3
0	1	12	1	Chnl 1,2 (sample 0)	Chnl 3,4 (sample 0)	Chnl 5,6 (sample 0)	Chnl 7,8 (sample 0)
1	0			Chnl 9, 10 (sample 0)	Chnl 11,12 (sample 0)	empty	empty

[91] Table 5 - Example of 3D Audio Sample Packet Layout for 24 channels

[92]

Packet #	Sample_start Value	Num Channels	samples	Subpkt 0	Subpkt 1	Subpkt 2	Subpkt 3
0	1	24	1	Chnl 1,2 (sample 0)	Chnl 3,4 (sample 0)	Chnl 5,6 (sample 0)	Chnl 7,8 (sample 0)
1	0			-	-	-	-
2	0			Chnl 17,18 (sample 0)	Chnl 19,20 (sample 0)	Chnl 21,22 (sample 0)	Chnl 23,24 (sample 0)

[93] Table 6 - Example of 3D Audio Sample Packet Layout for 32 channels (Max)

[94]

Packet #	Sample_start Value	Num Channels	samples	Subpkt 0	Subpkt 1	Subpkt 2	Subpkt 3
0	1	32 (Max)	1	Chnl 1,2 (sample 0)	Chnl 3,4 (sample 0)	Chnl 5,6 (sample 0)	Chnl 7,8 (sample 0)
1	0			-	-	-	-
2	0			-	-	-	-
3	0			Chnl 25,26 (sample 0)	Chnl 27,28 (sample 0)	Chnl 29,30 (sample 0)	Chnl 31,32 (sample 0)

[95] FIG. 1 illustrates timing of transmitting 3D audio signals.

[96] Referring to FIG. 1, in a horizontal blanking interval, three 2D audio signal samples of 8 channels each are transmitted. In the same time duration used in transmitting the above, one sample in a 3D audio signal of 24 channels is transmitted.

[97] Video Dependency

[98] Table 7 presents sample rates that can be available to transmit 3D audio at various video format timings described in CEA-861-F (also described in D or E). Assume that a 58 TMDS clock period of the horizontal blanking interval is necessary for content protection re-synchronization. Transmitting 3D audio may be supported by 3D audio sample packets.

[99] Table 7 presents a maximum sampling frequency of 3D audio for 24 bit video format timing.

[100] Table 7 - Maximum Sampling Frequency of 3D Audio for Video Format Timing

[101]

[101]

Description	Format Timing	Pixel Repetition	Vertical Freq (Hz)	Max fs 10.2ch (kHz)	Max fs 22.2ch (kHz)	Max fs 30.2ch (kHz)	Max frame rate 2ch, comp*
VGA	640x480p	none	59.9460	32	X	X	256
480i	1440x480i	2	59.9460	44.1	X	X	256
480p	2880x480p	4	59.9460	88	48	48	768
240p	1440x240p	2	59.9460	44.1	X	X	256
240p	2880x240p	4	59.9460	88	48	48	768
480p	720x480p	none	59.9460	X	X	X	192
480p	1440x480p	2	59.9460	88.2	48	44.1	705.6
480p	2880x480p	4	59.9460	192	98	98	1536
720p	1280x720p	none	59.9460	192	96	96	1536
1080i	1920x1080i	none	59.9460	96	48	48	768
1080p	1920x1080p	none	59.9460	192	98	98	1536
2160p	3840x2160p	none	59.9460	192	192	192	1536
2160p(SMPTE)	4096x2160p	none	59.9460	192	192	192	1536
480p120	1440x480p	2	119.89120	88.2	48	44.1	705.6
480p120	720x480p	none	119.89120	48	32	X	384
720p120	1280x720p	none	119.89120	192	102	102	1536
1080p120	1920x1080p	none	119.89120	192	98	98	1536
1080p120	1920x1080p	none	119.89120	192	192	192	1536
480p240	1440x480p	2	239.78240	176.4	96	88.2	1411.2
480p240	720x480p	none	239.78240	98	48	48	768
<b>58Hz Formats</b>							
576i	1440x576i	2	50	44.1	X	X	256
576p	2880x576p	4	50	88	48	48	768
288p	1440x288p	2	50	44.1	X	X	256
288p	2880x288p	4	50	88	48	48	768
576p	720x576p	none	50	X	X	X	192
576p	1440x576p	2	50	88.2	48	44.1	705.6
576p	2880x576p	4	50	192	98	98	1536
720p50	1280x720p	none	50	192	102	98	1536
1080p50	1920x1080p	none	50	192	176.4	98	1536
1080p50	1920x1080p	none	50	192	192	192	1536
2160p	3840x2160p	none	50	192	192	192	1536
2160p(SMPTE)	4096x2160p	none	50	192	192	192	1536
1080i120	1920x1080i	none	50	96	68.2	48	1024
576p100	1440x576p	2	100	88.2	48	44.1	705.6
576p100	720x576p	none	100	48	32	X	384
720p100	1280x720p	none	100	192	102	102	1536
1080p100	1920x1080p	none	100	192	192	192	1536
1080p100	1920x1080p	none	100	192	192	192	1536
576p200	1440x576p	2	200	176.4	96	88.2	1411.2
576p200	720x576p	none	200	88	48	48	768
<b>24-30Hz Formats</b>							
720p	1280x720p	none	24	192	192	192	1536
720p	1280x720p	none	25	192	192	192	1536
720p	1280x720p	none	29.97730	192	102	102	1536
1080p	1920x1080p	none	24	192	102	98	1536
1080p	1920x1080p	none	25	192	178.4	98	1536
1080p	1920x1080p	none	29.97730	96	48	48	768
2160p	3840x2160p	none	24	192	192	192	1536
2160p	3840x2160p	none	25	192	192	192	1536
2160p	3840x2160p	none	29.97730	192	192	192	1536
2160p(SMPTE)	4096x2160p	none	24	192	192	192	1536
2160p(SMPTE)	4096x2160p	none	25	192	192	192	1536
2160p(SMPTE)	4096x2160p	none	29.97730	192	96	96	1536

[102] Second Exemplary Embodiment

[103] According to the second exemplary embodiment, which is different from the first exemplary embodiment, a conventional audio sample packet format may be modified and used.

[104] As shown in Table 8 below, a reserved area of a conventional audio sample packet may be used as segment\_indicator. According to an exemplary embodiment, segment\_indicator may be expressed with two bits. If segment\_indicator=00, a first packet is indicated. Further, it is indicated that a packet is an odd packet of middle packets, if segment\_indicator=01, that a packet is an even packet of middle packets, if segment\_indicator=10 and that a packet is a last packet, if segment\_indicator=11. Also, the above identifiers are merely examples only, and packets matched with bits

may be different.

[105] The above structure can find if segments are damaged or not. If one segment is damaged, an nth sample having the damaged segment may be dropped, or only the damaged audio sample packet may be discarded. A segment indicates an individual audio sample packet in a group in which one audio sample packet or more are grouped.

[106] Layout indicates information regarding the number of samples and channels in HDMI 1.4b. For instance, one audio sample packet may include four audio samples of two channels or one audio sample of 8 channels. Expanded in this specification, layout\_ext field in a conventional reserved area is created, indicating information regarding whether a 3D audio is provided with layout.

[107] For instance, if layout\_ext=0 and layout=0, 1, the number of 2D audio samples and channels are indicated likewise according to a conventional method. However, if layout\_ext=1 and layout=0, 3D audio samples are indicated. If layout\_ext=1 and layout=1, multi-stream audio samples are indicated.

[108] Fields except for those described specifically in the description of the second exemplary embodiment may be the same as in the first exemplary embodiment.

[109] Table 8 - Modified Audio Sample Packet

[110]

Bit 7	Bit 6	Bit 5	Bit 4	Bit 3	Bit 2	Bit 1	Bit 0
Packet type - 0x02 (Audio Sample Packet)							
Segment_indictaor		Layout_ext	layout	Sample_pres ent.sp3	Sample_pres ent.sp2	Sample_pres ent.sp1	Sample_pres ent.sp0
B.3	B.2	B.1	B.0	Sample_flat.sp3	Sample_flat.sp2	Sample_flat.sp1	Sample_flat.sp0
Audio Sample Subpacket 0 (7Bytes)							
Audio Sample Subpacket 1 (7Bytes)							
Audio Sample Subpacket 2 (7Bytes)							
Audio Sample Subpacket 3 (7Bytes)							

[111] Table 8-1 segment\_indicator field

[112]

Segment_indicator	Description
00	Start_segment
01	mid_segment(odd)
10	mid_segment(even)
11	End_segment

[113] Table 8-2 retation between layout and layout\_exit : refer to table7-6 HDMI 1.4b

[114]

Layout_exit	layout	Description
0	0	2ch / 4 samples
0	1	8ch / 1 samples
1	0	3D Audio
1	1	Reserved

[115] FIG. 5 illustrates a transport stream of an audio sample packet according to the second exemplary embodiment.

[116] Referring to FIG. 5, each field value is established when transmitting two sample

packets in the horizontal blanking interval regarding 3D audio of 22.2 channels. In a first packet, a segment\_indicator=00, in a second packet, a segment\_indicator=10, and in a last packet, a segment\_indicator=11. Because the above examples are 3D audio signals, layout\_ext=1 and layout=0. Similar field values are found in 3D audio of 10.2 channels.

[117] Third Exemplary Embodiment

[118] According to a third exemplary embodiment, a conventional audio sample packet format is also altered and used while indicating less information as compared to the second exemplary embodiment.

[119] Referring to Table 9 below, a reserved area of a conventional audio sample packet may be used as multichannel\_indicator. Different from segment\_indicator of the second exemplary embodiment, multichannel\_indicator indicates information regarding whether an audio sample packet is 3D audio or not. According to bit information of multichannel\_indicator, information indicated by a layout field may change.

[120] Thus, multichannel\_indicator may be expressed with one bit. If multichannel\_indicator=0, a layout field indicates the channel/sample layout defined in traditional HDMI 1.4b. If multichannel\_indicator=1, layout field indicates the layout which transmits multi-channel audio sample data using more than 8 channels. In this case, layout is used in referring to a start of a sample. If layout=1, it indicates that a current audio sample packet includes a start of a sample. If layout(start)=0, it indicates that a current audio sample packet does not include a start of a sample. Also, the above description is exemplary only, and packets matched with bits may be different. Fields except for those described in the third exemplary embodiment are the same as in the first exemplary embodiment.

[121] Table 9 - Modified Audio Sample Packet Header

[122]

Bit 7	Bit 6	Bit 5	Bit 4	Bit 3	Bit 2	Bit 1	Bit 0
Packet type = 0x02 (Audio Sample Packet)							
reserved		Multichannel indicator	Layout/start	Sample_prese nt.sp3	Sample_prese nt.sp2	Sample_prese nt.sp1	Sample_prese nt.sp0
B.3	B.2	B.1	B.0	Sample_flat.s p3	Sample_flat.s p2	Sample_flat.s p1	Sample_flat.s p0
Audio sample subpacket 0 (7Bytes)							
Audio sample subpacket 1 (7Bytes)							
Audio sample subpacket 2 (7Bytes)							
Audio sample subpacket 3 (7Bytes)							

[123] Table 9-1 - Multichannel\_indicator and Layout/start

[124]

Multi-channel indicator	Layout/start	Description
0	0	2ch / 4 samples
0	1	8ch / 1 sample
1	0	Multi-channel / 1 sample (Non-start of sample)
1	1	Multi-channel / 1 sample (start of sample)

[125] The above structure minimizes changes in a reserved area of conventional audio sample packets while indicating information regarding whether 3D audio is included with an audio sample packet. Thus, the packet structure according to the third exemplary embodiment is simpler than the second exemplary embodiment.

[126] FIG. 6 illustrates a transport stream of audio sample packets in the third exemplary embodiment.

[127] Referring to FIG. 6, each field value is established when transmitting two sample packets in the horizontal blanking interval regarding 3D audio of 22.2 channels. In a first packet, layout=1, and in a second packet and a third packet, layout=0. However, because every packet is part of 3D audio signals, multichannel\_indicator=1. Similar field values are established in 3D audio of 10.2 channels.

[128] Fourth Exemplary Embodiment

[129] According to a fourth exemplary embodiment, a conventional audio sample packet format is also altered and used, but unlike the second exemplary embodiment, information regarding whether or not multi-stream audio is provided is further provided.

[130] Referring to Table 10 below, a reserved area of a conventional audio sample packet may be used as Stream\_ID and multiASP\_layout. multiASP\_layout performs the same function of multichannel\_indicator in the third exemplary embodiment. In other words, multiASP\_layout indicates whether or not 3D audio is provided. Information indicated by layout fields are different according to bit information of multiASP\_layout.

[131] Stream\_ID indicates stream numbers if multi-stream audio is provided. According to an exemplary embodiment, one bit may be used in Stream\_ID, and 0 indicates a first stream and 1 indicates a second stream. Each stream corresponds to a view of contents which are different from each other. Also, the above description is exemplary only, and packets matched with bits may be different.

[132] If one view corresponding to multi-stream audio has audio signals of 8 channels or less, it will not be found that Stream\_ID and multiASP\_layout are simultaneously 0 in one audio sample packet.

[133] Table 10 - Modified Audio Sample Packet Header

[134]

	Bit7	Bit6	Bit5	Bit4	Bit3	Bit2	Bit1	Bit0
HB0	Packet type = 0x02							
HB1	Stream_ID	multiASP_layout	reserved	Layout / start	Sample_present.sp3	Sample_present.sp2	Sample_present.sp1	Sample_present.sp0
HB2	B.3	B.2	B.1	B.0	Sample_flat.sp3	Sample_flat.sp2	Sample_flat.sp1	Sample_flat.sp0
SP0	Audio Sample Subpacket 0 (7Bytes)							
SP1	Audio Sample Subpacket 1 (7Bytes)							
SP2	Audio Sample Subpacket 2 (7Bytes)							
SP3	Audio Sample Subpacket 3 (7Bytes)							

[135] Table 10-1 - Description of Stream\_ID

[136]

Stream_ID	description
0	1 stream
1	2 stream

[137]

The above structure has the effect of achieving compatibility in displaying information of both multi-stream audio and 3D audio through one data sample packet. Further, if identifiers of Stream\_ID field and stream are created, a plurality of streams may be distinguished from each other when being transmitted. Thus, multi-stream audio sample data exceeding one packet size can be transmitted. Also in the fourth exemplary embodiment, fields except for those described specifically above are the same as in the first exemplary embodiment.

[138]

An audio data transport stream which combines values of Stream\_ID field, multiASP\_layout field and layout/start field may also be considered. If multiASP\_layout=1, a transport stream of 3D audio is indicated, and layout/start indicates information regarding a start of a packet. If Stream\_ID=1, multi-stream is indicated, and the number of channels and samples is established according to layout/start. For instance, a Sink which receives a packet in which Stream\_ID=1 recognizes that multi-stream audio data is transmitted and that the currently received packet is a second stream audio data of two multi-stream audio data.

[139]

Fifth Exemplary Embodiment

[140]

According to a fifth exemplary embodiment, a conventional audio sample packet format is also altered and used.

[141]

Referring to Table 11 below, a reserved area of a conventional audio sample packet may be used as Supports\_Multistream and multiASP\_layout. multiASP\_layout performs the same function of multiASP\_layout in the fourth exemplary embodiment. In other words, multiASP\_layout indicates whether or not 3D audio is provided. Information indicated by a layout field is different according to bit information of multiASP\_layout.

[142]

Supports\_Multistream indicates information regarding whether or not multi-stream audio is provided. According to an exemplary embodiment, one bit may be used in

Supports\_Multistream. 1 indicates that multi-stream audio is provided. Also, the above description is merely exemplary only, and packets matched with bits may be different.

[143] According to the fifth exemplary embodiment, one audio sample packet may include four multi-stream audio samples of 2 channels at a maximum. An audio sample in each view may be transmitted corresponding to each of four sub packets.

[144] If one view corresponding to multi-stream audio has audio signals having 8 channels or less, it will not be found that Supports\_Multistream and multiASP\_layout are 0 simultaneously in one audio sample packet.

[145] Table 11 - Modified Audio Sample Packet Header

[146]

	Bit7	Bit6	Bit5	Bit4	Bit3	Bit2	Bit1	Bit0
HB0	Packet type = 0x02							
HB1	Supports_Multistream	multiASP_layout	reserved	Layout / start	Sample_present.sp3	Sample_present.sp2	Sample_present.sp1	Sample_present.sp0
HB2	B.3	B.2	B.1	B.0	Sample_flat.sp3	Sample_flat.sp2	Sample_flat.sp1	Sample_flat.sp0
SP0	Audio Sample Subpacket 0 (7Bytes) : Reserved for 1 stream							
SP1	Audio Sample Subpacket 1 (7Bytes) : Reserved for 2 stream							
SP2	Audio Sample Subpacket 2 (7Bytes) : Reserved for 3 stream							
SP3	Audio Sample Subpacket 3 (7Bytes) : Reserved for 4 stream							

[147] The above structure has the effect of achieving compatibility in displaying information of both multi-stream audio and 3D audio through one data sample packet. Further, every feature to be supported may be written in one audio sample packet. Also in the fifth exemplary embodiment, fields except for those described specifically above are the same as in the first exemplary embodiment.

[148] Features of an audio data transport stream may be considered which combine values of Supports\_Multistream field, multiASP\_layout field and layout/start field. If Supports\_Multistream=0 and multiASP\_layout=1, 3D audio transport stream is indicated, and layout/start indicates information regarding a start of a packet. If Supports\_Multistream=1, a multi-stream is indicated, and the number of channels and samples is established according to layout/start.

[149] Sixth Exemplary Embodiment

[150] According to a sixth exemplary embodiment, an alteration of a conventional audio sample packet format similar to the fourth exemplary embodiment is suggested.

[151] Referring to Table 12 below, a reserved area of a conventional audio sample packet may be used as Stream\_ID and multiASP\_layout. Stream\_ID and multiASP\_layout perform the same function as Stream\_ID and multiASP\_layout in the fourth exemplary embodiment. Information indicated by the layout field is different according to bit information of multiASP\_layout.

[152] Since Stream\_ID is expressed with 2 bits, four stream numbers may be written if

multi-stream audio is provided. Combinations of bits which are different from each other correspond to views of contents which are different from each other.

[153] If one view of multi-stream audio has audio signals having 8 channels or less, it will not be found that Stream\_ID is more than 1 and multiASP\_layout is 1 in one audio sample packet.

[154] Table 12 - Modified Audio Sample Packet Header

[155]

	Bit7	Bit6	Bit5	Bit4	Bit3	Bit2	Bit1	Bit0
HB0	Packet type = 0x02 (Audio Sample packet)							
HB1	Stream_ID		multiA SP_lay out	Layout / start	Sample_pres ent.sp3	Sample_pres ent.sp2	Sample_pr esent.sp1	Sample_pres ent.sp0
HB2	B.3	B.2	B.1	B.0	Sample_flat. sp3	Sample_flat. sp2	Sample_fl at.sp1	Sample flat. sp0
SP0	Audio Sample Subpacket 0 (7Bytes)							
SP1	Audio Sample Subpacket 1 (7Bytes)							
SP2	Audio Sample Subpacket 2 (7Bytes)							
SP3	Audio Sample Subpacket 3 (7Bytes)							

[156] Table 12-1 - Description of Stream\_ID

[157]

Stream_ID	description
00	1 <sup>st</sup> stream
01	2 <sup>nd</sup> stream
10	3 <sup>rd</sup> stream
11	4 <sup>th</sup> stream

[158] The above structure has the effect of achieving compatibility in displaying information of both multi-stream audio and 3D audio through one data sample packet. Specifically, compared to the fourth exemplary embodiment, a greater number of multi-streams can be recognized. In the sixth exemplary embodiment, fields except for those described specifically above are the same as in the first exemplary embodiment.

[159] Table 13 presents features of an audio data transport stream which combines field values of Stream\_ID, multiASP\_layout, and layout/start. If multiASP\_layout=1, a 3D audio transport stream is indicated, and layout/start indicates information regarding a start of a packet. If Stream\_ID=01~11, a multi-stream is indicated, and the number of channels and samples is established according to layout/start.

[160] Table 13 - Capability to deal with proposed features according to exemplary embodiments

[161]

ASP header fields			Description
Stream_ID	multiASP_layout	Layout/start	
00b	0	Layout=0	24bits-sample + default (2ch/4sample)
00b	0	Layout=1	24bits-sample + default (8ch/1 sample)
00b	1	Start=0	24bits-sample + 3D audio-channel non-start ('N'ch/1 sample)
00b	1	Start=1	24bits-sample + 3D audio-channel start ('N'ch/1 sample)
00b~11b	0	Layout=0	24bits-sample + Multi-stream (2ch/4 sample)
00b~11b	0	Layout=1	24bits-sample + Multi-stream (8ch/1 sample)
1	1	0	Not supported ( refer to the '2 Analysis of proposed features (1/2) slide, page 8)
1	1	1	

[162] Seventh Exemplary Embodiment

[163] According to a seventh exemplary embodiment, a 3D audio sample packet and a multi-stream audio sample packet are transmitted using 3D audio sample packets which are newly defined in the first exemplary embodiment.

[164] The seventh exemplary embodiment is similar to the first exemplary embodiment, and further includes the feature of an ext\_layout field indicating whether or not multi-stream audio is transmitted. If ext\_layout=0, this field indicates that multi-stream audio is transmitted. If ext\_layout=1, this field indicates that 3D audio is transmitted.

[165] The extra fields of sample\_start field, sample\_present.spX field, and sample\_flat.spX field are the same as in the first exemplary embodiment, and will not be further described below. Table 14 indicates an audio sample packet structure according to the seventh exemplary embodiment.

[166] Table 14 - Extended Audio Sample Packet (24Channels Fs=96kHz)

N / Chan 1, 2	N / Chan 9, 10	N / Chan 17, 18	N+1 / Chan 1,2
N / Chan 3, 4	N / Chan 11, 12	N / Chan 19, 20	N+1 / Chan 3, 4
N / Chan 5, 6	N / Chan 13, 14	N / Chan 21, 22	N+1 / Chan 5, 6
N / Chan 7, 8	N / Chan 15, 16	N / Chan 23, 24	N+1 / Chan 7, 8

[168] Table 14-1 - Example of Extended Audio Sample Packet

Byte / Bit#	7	6	5	4	3	2	1	0
HB0	0	0	0	0	1	0	1	1
HB1	0	0	Sample_start=1	Ext_layout=1	Sample_present.sp3	Sample_present.sp2	Sample_present.sp1	Sample_present.sp0
HB2	B.3	B.2	B.1	B.0	Sample_flat.sp3	Sample_flat.sp2	Sample_flat.sp1	Sample_flat.sp0
PB0~PB6	Channel 1, 2 audio data / sample N							
PB7~PB13	Channel 3, 4 audio data / sample N							
PB14~PB20	Channel 5, 6 audio data / sample N							
PB21~PB27	Channel 7, 8 audio data / sample N							

[170] Table 15 indicates a packet body structure according to field values of ext\_layout. Referring to Table 15, regarding a multi-stream example, audio signals corresponding to one view may include 2 channels, and thus, one packet may include audio signals corresponding to 4 views. Also, regarding 3D audio signals, audio signals regarding a plurality of channels may be expressed. The above various exemplary embodiments

describe audio signals having 32 channels. However, exemplary embodiments are not limited to audio signals having 32 channels, and audio signals having more or less than 32 channels or more may be created according to other exemplary embodiments.

[171] Table 15 - EASP packetization

[172]

Ext_layout Value	Sample_start Value	Max Num Channels	samples	Subpkt 0	Subpkt 1	Subpkt 2	Subpkt 3
0	X	2	4	Chnl 1,2 Stream 0 (Sample M)	Chnl 1,2 Stream 1 (Sample M)	Chnl 1,2 Stream 2 (Sample M)	Chnl 1,2 Stream 2 (Sample M)
1	1	N	1	Chnl 1,2 Stream 0 (Sample M)	Chnl 3,4 Stream 0 (Sample M)	Chnl 5,6 Stream 0 (Sample M)	Chnl 7,8 Stream 0 (Sample M)
1	0			-	-	-	-
1	0			Chnl N-7,N-6 Stream 0 (Sample M)	Chnl N-5,N-4 Stream 0 (Sample M)	Chnl N-3,N-2 Stream 0 (Sample M)	Chnl N-1,N Stream 0 (Sample M)

[173] In the above exemplary embodiments, multi-stream audio signals may be included in an area corresponding to an area where image data of each view is placed in a vertical synchronization blanking interval and transmitted. FIG. 7 illustrates a transport stream format for the above description. Referring to FIG. 7, audio signals correspond to a left area of each view corresponding to an image signal.

[174] 1-2. 3D One Bit Audio Sample Packet

[175] First Exemplary Embodiment

[176] According to a first exemplary embodiment, 3D audio in a one bit audio format is transmitted using a newly defined 3D one bit audio sample packet. As described above, the definition of 3D audio according to exemplary embodiments is such that speakers can be placed anywhere in 3D space.

[177] A 3D one bit audio stream includes 32 audio channels or more, which are transmitted in a data island period through consecutive packets. Packet headers have sample\_start and sample\_present bits to indicate a position of a packet within a one bit audio sample.

[178] Table 16 - One Bit 3D Sample Packet Header

[179]

Byte/Bit#	7	6	5	4	3	2	1	0
HB0	0	0	0	0	1	1	0	0
HB1	Rsvd (0)	Rsvd (0)	Rsvd (0)	sample_start	samples_present sp3	Samples_present sp2	Samples_present sp1	Samples_present sp0
HB2	Rsvd (0)	Rsvd (0)	Rsvd (0)	Rsvd (0)	Samples_invalid sp3	Samples_invalid sp2	Samples_invalid sp1	Samples_invalid sp0

- [180] sample\_start: [1bit] indicates that current packet is a first packet of 3D one bit audio samples, if sample\_start=1. sample\_start is the same as described above in 3D audio packets, and will not be further described.
- [181] samples\_present.spX: [4 fields, 1 bit each] indicates whether sub packet X includes an audio sample or not. Four sample\_present bits may be included in a 3D one bit audio sample packet header, and each sample\_present bit is created for each sub packet. If a sub packet includes an audio sample, a corresponding bit is established. sample\_present.spX is the same as described above.
- [182] samples\_invalid.spx: [4 fields, 1 bit each] indicates whether sub packet X refers to an invalid sample. If sample\_invalid=1, samples of sub packet X are not valid. 0 indicates the samples of sub packet X are valid. The above bits are valid only if sample\_present.spX is established. If available audio data that can be used in sources is not found, four sample\_invalid.spX bits are established. If sample\_invalid.spX is established, sub packet X refers to a continuous sample period. However, any available data is not included.
- [183] In 3D one bit audio, sample frequency information is included and transmitted in audio InfoFrame (please refer to HDMI 1.4b Section 8.2.2).
- [184] A sample packet of a 3D one bit audio sample packet includes a one bit audio sample packet header as shown in Table 16 and four sub packets. Each sub packet may include a one bit audio bit for four audio channels at a maximum.
- [185] Adjacent 3D one bit audio sample packets may be used in transmitting 3D one bit audio samples between 9 to 32 audio channels. Available combinations of sample\_present bits for 3D one bit audio sample packets are determined by allocating allowed channels. A 3D one bit audio sample packet does not have B0~B3 fields which is different from a 3D audio sample packet because the 3D one bit audio sample packet does not conform to the IEC 60958 block format.
- [186] Various Alternatives
- [187] Meanwhile, regarding various exemplary embodiments of the 3D audio sample packet, a corresponding 3D one bit audio sample packet may be defined respectively. A 3D one bit audio sample packet may be defined as the same as a 3D audio sample packet except for the difference of sample\_invalid.spX field described above, and only B0~B3 fields may be excluded from a 3D audio sample packet. Other explanations are the same as in the above descriptions, which will not be further described.
- [188] 1-3. Multi Stream Audio Sample Packet
- [189] In the following, a newly suggested multi-stream audio sample packet structure will be explained. A first exemplary embodiment will be described, and other various alternative exemplary embodiments will be explained based on differences from the first exemplary embodiment.

[190] First Exemplary Embodiment

[191] According to a first exemplary embodiment, a plurality of audio streams in L-PEM and IEC 61937 compression audio formats are transmitted using multi-stream audio sample packets. Each audio stream included in a multi-stream audio sample has two audio channels or more. Establishing a sub packet is determined by using a stream\_present bit of a packet header. Table 17 presents a header structure of multi-stream audio sample packet.

[192] Table 17 - Multi-Stream Audio Sample Packet Header

[193]

Byte/Bit#	7	6	5	4	3	2	1	0
HB0	0	0	0	0	1	1	1	0
HB1	Rsvd (0)	Rsvd (0)	Rsvd (0)	Rsvd (0)	stream_present_sp3	stream_present_sp2	stream_present_sp1	stream_present_sp0
HB2	B.3	B.2	B.1	B.0	Stream_flat.sp3	Stream_flat.sp2	Stream_flat.sp1	Stream_flat.sp0

[194] stream\_present.spX: [4 fields, 1 bit each] indicates whether sub packet X includes an audio sample of stream X. Four stream\_present bits are created in a multi-stream audio sample packet header, and each is created for a corresponding sub packet. The stream\_present bit indicates whether a corresponding sub packet includes an audio stream. Since stream\_present.spX substantially performs the same function as sample\_present.spX in the 3D audio sample packet, a description of this feature will not be explained.

[195] stream\_flat.spX: [4 fields, 1 bit each] indicates whether sub packet X refers to a flatline sample of stream X. The stream\_flat.spX is valid only if stream\_present.spX is established. If available audio data is not found in sources, four stream\_flat.spX bits are established. The establishing of a stream\_flat.spX bit is implemented while a sample rate changes or a temporary stream interruption exists. If a stream\_flat.spX bit is established, sub packet X continuously indicate a sample period, however, does not include available audio data. stream\_flat.spX is substantially the same as sample\_flat.spX of the 3D audio sample packet, and will not be further described below.

[196] If sub packet X includes a first frame of 192 frames constituting IEC 60958, B.X=1. Otherwise, B.X=0.

[197] A multi-stream audio sample packet uses the packet header shown in Table 17 and four sub packets. Every sub packet has the same structure.

[198] HDMI allows that sources may simultaneously transmit four audio streams if multi view video streaming (e.g., dual view/quad view games having different audio in each view) is supported. Each audio stream included in a multi-stream audio sample relates to one single view and include two audio channels. A sub packet of each multi-stream audio sample packet has frames configured according to an IEC 60958 or IEC 61937

block defined by 0 or 1 IEC 60958. Three sub packet layouts are defined. Tables 18 to 20 below present examples of multi-stream audio packet layouts for 2, 3, and 4 audio streams.

[199] Table 18 - Example of Multi-Stream Audio Sample Packet Layout for 2 Audio Streams

[200]

Num Streams	Packet #	Max Num Channels	samples	Subpkt 0	Subpkt 1	Subpkt 2	Subpkt 3
2	0	2 ch /stream	1 sample /stream	Chnl 1,2 Stream 0 (Sample a)	Chnl 1,2 Stream 1 (Sample b)	Empty	empty
	1	2 ch /stream	1 sample /stream	Chnl 1,2 Stream 0 (Sample a+1)	Chnl 3,4 Stream 1 (Sample b+1)	empty	empty
				-	-	-	
	N	2 ch /stream	1 sample /stream	Chnl 1,2 Stream 0 (Sample a+N)	Chnl 1,2 Stream 1 (Sample b+N)	empty	empty

[201] Table 19 - Example of Multi-Stream Audio Sample Packet Layout for 3 Audio Streams

[202]

Num Streams	Packet #	Max Num Channels	samples	Subpkt 0	Subpkt 1	Subpkt 2	Subpkt 3
3	0	2 ch /stream	1 sample /stream	Chnl 1,2 Stream 0 (Sample a)	Chnl 1,2 Stream 1 (Sample b)	Chnl 1,2 Stream 2 (Sample c)	empty
	1	2 ch /stream	1 sample /stream	Chnl 1,2 Stream 0 (Sample a+1)	Chnl 1,2 Stream 1 (Sample b+1)	Chnl 1,2 Stream 2 (Sample c+1)	empty
				-	-	-	
	N	2 ch /stream	1 sample /stream	Chnl 1,2 Stream 0 (Sample a+N)	Chnl 1,2 Stream 1 (Sample b+N)	Chnl 1,2 Stream 2 (Sample c+N)	empty

[203] Table 20 - Example of Multi-Stream Audio Sample Packet Layout for 4 Audio Streams

[204]

Num Streams	Packet #	Max Num Channels	samples	Subpkt 0	Subpkt 1	Subpkt 2	Subpkt 3
4	0	2 ch /stream	1 sample /stream	Chnl 1,2 Stream 0 (Sample a)	Chnl 1,2 Stream 1 (Sample b)	Chnl 1,2 Stream 2 (Sample c)	Chnl 1,2 Stream 2 (Sample d)
	1	2 ch /stream	1 sample /stream	Chnl 1,2 Stream 0 (Sample a+1)	Chnl 1,2 Stream 1 (Sample b+1)	Chnl 1,2 Stream 2 (Sample c+1)	Chnl 1,2 Stream 3 (Sample d+1)
				-	-	-	
	N	2 ch /stream	1 sample /stream	Chnl 1,2 Stream 0 (Sample a+N)	Chnl 1,2 Stream 1 (Sample b+N)	Chnl 1,2 Stream 2 (Sample c+N)	Chnl 1,2 Stream 3 (Sample d+N)

[205] FIG. 8 illustrates a transport stream of audio sample packets according to the first exemplary embodiment.

[206] Referring to FIG. 8, regarding a 2 channel audio sample packet for dual view, one sample packet including two samples is transmitted in the horizontal blanking interval. Regarding a 2 channel audio sample packet for quad view, one sample packet including four samples is transmitted in the horizontal blanking interval. Even though the diagram describes transmitting multi-stream audio samples of 2 channels at maximum, multi-stream audio samples having a plurality of channels which include more than 2 channels may be transmitted through one multi-stream audio sample packet according to other exemplary embodiments. In short, audio corresponding to each view may be transmitted through a corresponding sub packet; also, multi-stream audio sample data having a plurality of channels which include more than 2 channels may be transmitted though one or more consecutive multi-stream audio sample packets.

[207] According to exemplary embodiments, multi-stream audio sample packets transmit four stereo audio samples. Each sample corresponds to an individual audio stream. For instance, if HDMI sources transmit two divided audio streams, sub packet 0 may be used in transmitting audio samples of stream 0 and sub packet 1 may be used in transmitting audio samples of stream 1.

[208] Second Exemplary Embodiment

[209] According to a second exemplary embodiment, a conventional audio sample packet format is altered and used while further providing information regarding whether or not multi-stream audio is provided.

[210] Referring to Table 21 below, a reserved area of a conventional audio sample packet may be used as Stream\_Identifier (Stream\_ID). Stream\_ID indicates a stream number if multi-stream audio is provided. According to an exemplary embodiment, Stream\_ID may use two bits; 00 indicates a first stream, 01 indicates a second stream, and so on.

Each stream corresponds to a view of contents which are different from each other. Also, the above description is exemplary only, and packets matched with bits may be different.

[211] In HDMI 1.4b, layout indicates information regarding the number of samples and channels. For instance, one audio sample packet may include four samples of 2 channel audio and one sample of 8 channel audio.

[212] Table 21 - Modified Audio Sample Packet Header

[213]

	Bit7	Bit6	Bit5	Bit4	Bit3	Bit2	Bit1	Bit0
HB0	Packet type = 0x02 (Audio Sample Packet)							
HB1	Stream_Identifier	reserved	Layout	Sample_present_sp3	Sample_present_sp2	Sample_present_sp1	Sample_present_sp0	
HB2	B.3	B.2	B.1	B.0	Sample_flat_sp3	Sample_flat_sp2	Sample_flat_sp1	Sample flat_sp0
SP0	Audio Sample Subpacket 0 (7Bytes)							
SP1	Audio Sample Subpacket 1 (7Bytes)							
SP2	Audio Sample Subpacket 2 (7Bytes)							
SP3	Audio Sample Subpacket 3 (7Bytes)							

[214] Table 21-1 - Description of Stream\_Identifier

[215]

Stream_Identifier	Description
00	Stream_1
01	Stream_2
10	Stream_3
11	Stream_4

[216] The above structure achieves the advantage of providing IDs of a multi-stream in a simple fashion using a traditional reserved area.

[217] FIGS. 9 and 10 illustrate transport streams of multi-stream audio sample packets according to the second exemplary embodiment.

[218] Referring to FIG. 9, regarding a 2 channel audio sample packet for dual view, one sample packet including four units of sample data of the same contents is transmitted in the horizontal blanking interval. In other words, one sample packet includes audio signals regarding one view. Regarding 2 channel audio sample packets for quad view, four sample packets for four views are transmitted in the horizontal blanking interval. Further, sample packets of any one of the views may be transmitted consecutively or sample packets may be transmitted in an alternating fashion with another view. FIG. 9 illustrates an example of a 2 channel audio sample packet; however, an audio sample packet having a plurality of channels including more than 2 channels may be also applied. Further, as illustrated, the same determined number of sample data may be included and transmitted in each view; however, different numbers of sample data may also be transmitted.

[219] FIG. 10 illustrates transmitting 8 channel audio sample packets for dual view including sample data indicating 8 channels and two sample packets in the horizontal blanking interval. With one sample packet, the transmission of sample data regarding one view may be completed. Sample packets of each view may be transmitted consecutively or in an alternating fashion with sample packets for another view. Regarding 8 channel audio sample packets for quad view, one sample packet including sample data for one type of contents may be transmitted in the horizontal blanking interval; however, each sample packet of four views should be transmitted.

[220] Similar to the second exemplary embodiment, if Stream\_Identifier is used, and if an audio clock regeneration packet includes the above information, the operation of synchronizing video and audio may be implemented more efficiently. Table 22 below presents a structure of a modified audio clock regeneration packet according to the second exemplary embodiment.

[221] Table 22 - Audio Clock Regeneration Packet Header and Subpacket

[222] Table 22-1 Audio Clock Regeneration Packet Header

[223]

Byte/Bit#	7	6	5	4	3	2	1	0
HB0	0	0	0	0	1	0	1	1
HB1	0	0	0	0	0	0	0	0
HB2	0	0	0	0	0	0	0	0

[224] Table 22 -2 Audio clock Regeneration subpacket

[225]

Byte/Bit#	7	6	5	4	3	2	1	0
SB0	0	0	0	0	0	0	Stream identifier	
SB1	0	0	0	0	CTS 19	-	-	CTS 16
SB2	CTS 15	-	-	-	-	-	-	CTS 8
SB3	CTS 7	-	-	-	-	-	-	CTS 0
SB4	0	0	0	0	N 19	-	-	N 16
SB5	N 15	-	-	-	-	-	-	N 8
SB6	N 7	-	-	-	-	-	-	N 0

[226] Table 22- 3 Description of Stream\_Identifier

[227]

Stream_Identifier	Description
00	Stream_1
01	Stream_2
10	Stream_3
11	Stream_4

[228] Referring to Table 22, by including information regarding a multi-stream index in a reserved area of an audio clock regeneration packet, video and audio of a multi-view system may be implemented efficiently. Specifically, regarding systems that do not display multi view simultaneously, the above packet structure may be useful.

[229] Third Exemplary Embodiment

[230] A third exemplary embodiment is similar to a 3D audio sample packet of the fourth

exemplary embodiment. A conventional audio sample packet form is altered and used while having functions of providing multi-stream identifying information.

[231] Referring to Table 23 below, a reserved area of a conventional audio sample packet may be used as Stream\_ID and multiASP\_layout. Stream\_ID and multiASP\_layout are the same as those described in a 3D audio sample packet of the fourth exemplary embodiment.

[232] Table 23 - Modified Audio Sample Packet Header

[233]

	Bit7	Bit6	Bit5	Bit4	Bit3	Bit2	Bit1	Bit0
HB 0	Packet type = 0x02)							
HB 1	Stream_ID	multi ASP_layout	reserved	Layout / start	Sample_present.sp3	Sample_present.sp2	Sample_present.sp1	Sample_present.sp0
HB 2	B.3	B.2	B.1	B.0	Sample_flags.sp3	Sample_flags.sp2	Sample_flags.sp1	Sample_flags.sp0
SP0	Audio Sample Subpacket 0 (7Bytes)							
SP1	Audio Sample Subpacket 1 (7Bytes)							
SP2	Audio Sample Subpacket 2 (7Bytes)							
SP3	Audio Sample Subpacket 3 (7Bytes)							

[234] Table 23 -1 - Description of Stream\_Identifier

[235]

Stream_Identifier	Description
0	1 <sup>st</sup> Stream
01	2 <sup>nd</sup> Stream

[236] The above structure has an advantage of achieving compatibility in displaying information of both multi-stream audio and 3D audio through one data sample packet.

[237] Features of an audio data transport stream according to a combination of values of Stream\_ID field, multiASP\_layout field and layout/start field are the same as those described above with respect to the 3D audio sample packet of the fourth exemplary embodiment.

[238] **Fourth Exemplary Embodiment**

[239] According to a fourth exemplary embodiment, a conventional audio sample packet format may be altered and used. The fourth exemplary embodiment corresponds to a 3D audio sample packet of the fifth exemplary embodiment.

[240] Referring to Table 24 below, a reserved area of a conventional audio sample packet may be used as Supports\_Multistream and multiASP\_layout. Supports\_Multistream and multiASP\_layout are the same as those described in a 3D audio sample packet of the fifth exemplary embodiment.

[241] Table 24 - Modified Audio Sample Packet Header

[242]

	Bit7	Bit6	Bit5	Bit4	Bit3	Bit2	Bit1	Bit0
HB0	Packet type = 0x02							
HB1	Supports_Multistream	multiASP_layout	reserved	Layout / start	Sample_present.sp3	Sample_present.sp2	Sample_present.sp1	Sample_present.sp0
HB2	B.3	B.2	B.1	B.0	Sample_flat.sp3	Sample_flat.sp2	Sample_flat.sp1	Sample_flat.sp0
SP0	Audio Sample Subpacket 0 (7Bytes) : Reserved for 1 stream							
SP1	Audio Sample Subpacket 1 (7Bytes) : Reserved for 2 stream							
SP2	Audio Sample Subpacket 2 (7Bytes) : Reserved for 3 stream							
SP3	Audio Sample Subpacket 3 (7Bytes) : Reserved for 4 stream							

[243] The above structure has an advantage of achieving compatibility in displaying information of both multi-stream audio and 3D audio through one data sample packet. Further, the above structure also achieves another advantage in that every feature to be supported can be written in one audio sample packet.

[244] Features of an audio data transport stream may be implemented according to a combination of values of Supports\_Multistream field, multiASP\_layout field and layout/start field. Each field value is the same as in Table 13 of a 3D audio sample packet as described above.

[245] Meanwhile, in the above exemplary embodiments, multi-stream audio signals may be included and transmitted in an area corresponding to an area where image data of each view is placed in the vertical synchronization blanking interval. The description of FIG. 7 provides a detailed description of this feature.

[246] Fifth Exemplary Embodiment

[247] A fifth exemplary embodiment proposes a modified method of a conventional audio sample packet format, similar to the third exemplary embodiment.

[248] Referring to Table 25 below, a reserved area of a conventional audio sample packet may be used as Stream\_ID and multiASP\_layout. Stream\_ID and multiASP\_layout perform the same functions as Stream\_ID and multiASP\_layout in the third exemplary embodiment, respectively.

[249] Since Stream\_ID is expressed with two bits, four stream numbers may be indicated if multi-stream audio is provided. Each different combination of bits corresponds to a view of contents which are different from each other.

[250] If one view of multi-stream audio has audio signals having 8 channels or less, it will not be found that Stream\_ID is more than 1 and multiASP\_layout is 1 for one audio sample packet.

[251] Table 25 - Modified Audio Sample Packet Header

[252]

	Bit7	Bit6	Bit5	Bit4	Bit3	Bit2	Bit1	Bit0
HB0	Packet type = 0x02 (Audio Sample Packet)							
HB1	Stream_ID		multiASP_layout	Layout / start	Sample_present.sp3	Sample_present.sp2	Sample_present.sp1	Sample_present.sp0
HB2	8.3	8.2	8.1	8.0	Sample_flat.sp3	Sample_flat.sp2	Sample_flat.sp1	Sample_flat.sp0
SP0	Audio Sample Subpacket 0 (7Bytes)							
SP1	Audio Sample Subpacket 1 (7Bytes)							
SP2	Audio Sample Subpacket 2 (7Bytes)							
SP3	Audio Sample Subpacket 3 (7Bytes)							

[253] Table 25-1 - Description of Stream\_Identifier

[254]

Stream_Identifier	Description
00	1 <sup>st</sup> stream
01	2 <sup>nd</sup> stream
10	3 <sup>rd</sup> stream
11	4 <sup>th</sup> stream

[255] The above structure has an advantage of achieving compatibility in displaying information of both multi-stream audio and 3D audio though one data sample packet. Specifically, compared to the third exemplary embodiment, a greater number of multi-streams can be distinguished.

[256] Table 26 presents features of an audio data transport stream which combines values of Stream\_ID field, multiASP\_layout field and layout/start field. If multiASP\_layout=1, a 3D audio transport stream is indicated, and layout/start indicates information regarding a start of a packet. If Stream\_ID=01~11, multi-streams are indicated, and the number of channels and samples is established according to layout/start.

[257] Table 26 - Capability to deal with Proposed Features According to Exemplary Embodiments

[258]

ASP header fields			Description
Stream_ID	multiASP_layout	Layout/start	
00b	0	Layout=0	24bits-sample+default (2ch/4sample)
00b	0	Layout=1	24bits-sample+default (3ch/1sample)
00b	1	Start=0	24bits-sample+3D-audio-channel non-start('N' ch/1sample)
00b	1	Start=1	24bits-sample+3D-audio-channel start('N' ch/1sample)
00b~11b	0	Layout=0	24bits-sample+Multi-stream(2ch/4sample)
00b~11b	0	Layout=1	24bits-sample+Multi-stream(3ch/1sample)
1	1	0	Not supported
1	1	1	(refer to the 2. Analysis of proposed features (1/2)" slide. Poage8)

[259] Sixth Exemplary Embodiment

[260] A sixth exemplary embodiment proposes adding Stream\_ID to audio sample packets

according to the first exemplary embodiment. Stream\_ID is the same as described above, and other fields are the same as described in the first exemplary embodiment. Table 27 presents an audio sample packet header according to the sixth exemplary embodiment. However, even though Stream\_ID is established with 4 bits in the table, it may be also established with 1~3 bits, or 5 bits or more. Packet type indicates a newly defined packet type.

[261] To distinguish audio in each stream, Stream\_ID is used. Thus, in contrast to the first exemplary embodiment, one multi-stream audio sample packet includes audio sample data for one stream.

[262] Table 27 - Extension Audio Sample Packet

[263]

	Bit7	Bit6	Bit5	Bit4	Bit3	Bit2	Bit1	Bit0
HB0	Packet type = 0x02 (Multi-Stream Audio Sample Packet)							
HB1	Stream_ID				Sample_present.sp3	Sample_present.sp2	Sample_present.sp1	Sample_present.sp0
HB2	B.3	B.2	B.1	B.0	Sample_flat.sp3	Sample_flat.sp2	Sample_flat.sp1	Sample_flat.sp0
SP0	Audio Sample Subpacket 0 (7Bytes)							
SP1	Audio Sample Subpacket 1 (7Bytes)							
SP2	Audio Sample Subpacket 2 (7Bytes)							
SP3	Audio Sample Subpacket 3 (7Bytes)							

[264] Seventh Exemplary Embodiment

[265] A seventh exemplary embodiment proposes a 3D audio sample packet and a multi-stream audio sample packet using a 3D audio sample packet which is newly defined in the first exemplary embodiment of section 1.1.

[266] The seventh exemplary embodiment is similar to the first exemplary embodiment, and further includes an ext\_layout field indicating whether or not multi-stream is provided. Thus, if ext\_layout=0, this field indicates that multi-stream audio is transmitted. If ext\_layout=1, this field indicates that 3D audio is transmitted.

[267] Other fields including the sample\_start field, sample\_present.spX field, and sample\_flat.spX field are the same as described in the first exemplary embodiment, and will not be further described. Table 28 presents an audio sample packet structure according to the seventh exemplary embodiment.

[268] Table 28 - Extended Audio Sample Packet(2channels 2streams Fs=96kHz)

[269]

N/chan 1,2 (Stream 1)	N/chan 1,2 (Stream 1)	N/chan 1,2 (Stream 1)
N/chan 1,2 (Stream 1)	N/chan 1,2 (Stream 1)	N/chan 1,2 (Stream 1)
-	-	-
-	-	-

[270] Table 28 -1 Example of extended audio sample packet

[271]

Byte / Bit#	7	6	5	4	3	2	1	0
HB0	0	0	0	0	1	0	1	1
HB1	0	0	Sample_start=X	Ext_layout=0	Sample_present.sp3=0	Sample_present.sp2=0	Sample_present.sp1=1	Sample_present.sp0=1
HB2	B.3	B.2	B.1	B.0	Sample_fl at.sp3	Sample_fl at.sp2	Sample_fl at.sp1	Sample_fl at.sp0
PB0~PB6	Channel 1, 2 audio data / sample N(Stream 1)							
PB7~PB13	Channel 1, 2 audio data / sample M(Stream 2)							
PB14~PB20	-							
PB21~PB27	-							

[272] Table 29 indicates a packet body structure according to field values of ext\_layout. As illustrated, in multi-stream, audio signals corresponding to one view may include 2 channels, and thus, one packet may include audio signals for 4 views. Alternatively, in 3D audio signals, audio signals for a plurality of channels may be indicated. Even though the various exemplary embodiments described in this specification describe 3D audio for up to 32 channels, the exemplary embodiments are not limited thereto. For example, the exemplary embodiments can be applied to audio signals having 32 channels or more.

[273] Table 29 - EASP packetization

[274]

Ext_layout Value	Sample_start Value	Max Num Channels	Samples	Subpkt 0	Subpkt 1	Subpkt 2	Subpkt 3
0	X	2	4	Chnl 1,2 Stream 0 (Sample M)	Chnl 1,2 Stream 1 (Sample M)	Chnl 1,2 Stream 2 (Sample M)	Chnl 1,2 Stream 3 (Sample M)
1	1	N	1	Chnl 1,2 Stream 0 (Sample M)	Chnl 3,4 Stream 0 (Sample M)	Chnl 5,6 Stream 0 (Sample M)	Chnl 7,8 Stream 0 (Sample M)
1	0			-	-	-	-
1	0			Chnl N-7,N-6 Stream 0 (Sample M)	Chnl N-5,N-4 Stream 0 (Sample M)	Chnl N-3,N-2 Stream 0 (Sample M)	Chnl N-1,N Stream 0 (Sample M)

[275] Table 30 presents valid Sample\_Present bits.

[276] Table 30 - Valid Sample\_Present Bit Configurations for Multiple Audio Stream Transmission

[277]

SP0	SP1	SP1	SP3	Description
0	0	0	0	No Subpackets contain audio samples.
1	0	0	0	Only Subpacket 0 contains audio samples for stream 0
1	1	0	0	Subpackets 0 and 1 contain audio samples for stream 0 and 1
1	1	1	0	Subpackets 0, 1 and 2 contain audio samples for stream 0,1 and 2
1	1	1	1	All subpackets contain audio samples for stream 0,1,2, and 3

[278] FIG. 11 illustrates a transport stream of a multi-stream audio sample packet in the above seventh exemplary embodiment.

[279] Referring to FIG. 11, one sample packet including a sample of two views may be transmitted in the horizontal blanking interval regarding 2 channel audio sample packets for dual view. Regarding 2 channel audio sample packets for quad view, one sample packet including four samples is transmitted in the horizontal blanking interval. In other words, one sample packet includes and transmits samples of four views. Although FIG. 11 illustrates an example of a 2 channel audio sample packet, an audio sample packet having a plurality of channels including more than 2 channels may be applied according to other exemplary embodiments.

[280] As described above with respect to the above various exemplary embodiments, multi-stream audio signals may be included and transmitted in an area corresponding to the area where image data of each view is placed in the vertical synchronization blanking interval. FIG. 11 illustrates a transport stream format in this case. In FIG. 11, audio signals corresponding to a left area of image signals in each view may be included.

[281] 1-4. Multi-Stream One Bit Audio Packet

[282] First Exemplary Embodiment

[283] According to this first exemplary embodiment, a new packet for multi-stream one bit audio is defined. This corresponds to a 3D audio sample packet.

[284] If transmitting multi-stream one bit audio, each sub packet may include a one bit audio bit for 0, 1, 2 or more audio channels. A multi-stream one bit audio sample includes four stream\_present bits, and each bit is created for a corresponding sub packet.

[285] If a sub packet includes an audio sample in each stream, a corresponding bit may be established. Four stream\_invalid.spX bits may be established if available audio data that can be used are not found. If a stream\_invalid.spX bit is established, sub packet X continuously indicate a sample period, however, does not include any available data.

[286] Table 31 - Multi-Stream One Bit Audio Packet Header

[287]

Byte/Bit#	7	6	5	4	3	2	1	0
HB0	0	0	0	0	1	1	1	1
HB1	Rsvd (0)	Rsvd (0)	Rsvd (0)	Rsvd (0)	samples_present_sp3	Samples_present_sp2	Samples_present_sp1	Samples_present_sp0
HB2	Rsvd (0)	Rsvd (0)	Rsvd (0)	Rsvd (0)	Samples_invalid_sp3	Samples_invalid_sp2	Samples_invalid_sp1	Samples_invalid_sp0

[288] stream\_present.spX: [4 fields, 1 bit each] indicates whether sub packet X has an audio sample of stream X. stream\_present.spX substantially performs the same function as sample\_present.spX described above with respect to the above 3D audio sample packet, and thus will not be further explained.

[289] stream\_invalid.spX: [4 fields, 1 bit each] indicates whether sub packet X refers to an

invalid sample of stream X. If samples included in sub packet X are not valid, stream\_invalid=1. Otherwise, stream\_invalid=0. Bits are valid only if related stream\_present.spX is established. stream\_present.spX substantially performs the same function as sample\_present.spX described above with respect to the above 3D audio sample packet, and will not be further explained.

[290] Regarding multi-stream one bit audio, according to exemplary embodiments, sample frequency information is included and transmitted in an audio InfoFrame (see section 8.2.2 of HDMI 1.4b).

[291] A multi-stream one bit audio sample packet uses the same four sub packets as a one bit audio sample sub packet shown in Table 31. Since a multi-stream one bit audio sample packet does not conform to IEC 60958 block format, a multi-stream one bit audio sample packet does not have B0~B3 fields, which is different from a multi-stream audio sample packet.

[292] Various Alternatives

[293] Regarding the various above described exemplary embodiments of multi-stream audio sample packets, corresponding one bit multi-stream audio sample packet may be defined, respectively. In other words, beside samples\_invalid.spX, as described above, a one bit multi-stream audio sample packet may be defined as a multi-stream audio sample packet, and B0~B3 fields from a multi-stream audio sample packet may be used.

[294] In the following, a data transreceiving system 1000 according to a first exemplary embodiment will be described.

[295] FIG. 2 is a block diagram illustrating a configuration of the data transreceiving system 1000 according to an exemplary embodiment, FIG. 3 is a block diagram illustrating a configuration of a data transmitting apparatus 100 of the data transreceiving system 1000, and FIG. 4 is a block diagram illustrating a configuration of a data receiving apparatus 200 of the data transreceiving system 1000.

[296] As illustrated in FIG. 2, the data transreceiving system 1000 according to an exemplary embodiment includes the data transmitting apparatus 100 and the data receiving apparatus 200.

[297] As illustrated in FIG. 3, the data transmitting apparatus 100 according to an exemplary embodiment includes a packet generator 110 and a transmitter 120.

[298] The packet generator 110 generates a packet including a plurality of sub packets. That is, as described above, the packet generator 110 generates a multistream audio packet including the plurality of sub packets. At this time, each of the plurality of sub packets may include audio data corresponding to content (e.g., any one unit of content) among a plurality of contents.

[299] The transmitter 120 transmits the generated packet to a data receiving apparatus.

[300] At this time, each of the plurality of sub packets may further include an identification field representing whether each of the plurality of sub packets indicates content among the plurality of contents.

[301] As illustrated in FIG. 4, the data receiving apparatus 200 according to an exemplary embodiment includes a receiver 210 and a packet parsing unit 220.

[302] The receiver 210 receives a packet including a plurality of sub packets.

[303] The packet parsing unit 220 performs an operation of parsing on the plurality of received sub packets. Each of the plurality of sub packets includes audio data corresponding to content (e.g., any one unit of content) among a plurality of contents.

[304]

[305] 2-1. InfoFrame for 3D Audio/Metadata Packet

[306] First Exemplary Embodiment

[307] As described above, in a first exemplary embodiment, additional information related to 3D audio may be transmitted by utilizing newly defined audio metadata packets instead of InfoFrame. Sources transmit audio metadata once for at least two video fields whenever transmitting a 3D audio stream.

[308] Audio metadata may indicate various characteristics, such as the number of channels, an Audio Channel Allocation Standard Type (ACAT), and allocations of channel/speaker of a 3D audio stream. The following tables present a newly defined audio metadata packet header.

[309] Table 32 - Audio Metadata Packet Header

[310]

Byte/Bit#	7	6	5	4	3	2	1	0
HB0	0	0	0	0	1	1	0	1
HB1	Rsvd (0)	Rsvd (0)	Rsvd (0)	Rsvd (0)	Rsvd (0)	Rsvd (0)	Rsvd (0)	Rsvd (0)
HB2	Rsvd (0)	Rsvd (0)	Rsvd (0)	Rsvd (0)	Rsvd (0)	Rsvd (0)	Rsvd (0)	Rsvd (0)

[311] Table 33 - Audio Metadata Packet Contents

[312]

Byte/Bit#	7	6	5	4	3	2	1	0
PB0	Rsvd (0)	Rsvd (0)	Rsvd (0)	3D_CC4	3D_CC3	3D_CC2	3D_CC1	3D_CC0
PB1	Rsvd (0)	Rsvd (0)	Rsvd (0)	Rsvd (0)	ACAT3	ACAT2	ACAT1	ACAT0
PB2	3D_CA7	3D_CA6	3D_CA5	3D_CA4	3D_CA3	3D_CA2	3D_CA1	3D_CA0
PB2 PB27	Reserved (0)							

[313] Each field of the above packets is defined as follows.

[314] 3D\_CC: [5 bits] indicates a channel count of transmitted 3D audio. If an audio channel count (CC0, ... , CC2) in an audio InfoFrame is not consistent with a 3D audio channel count (3D\_CC0, ... , 3D\_CC4) in an audio metadata packet, the channel count of the audio InfoFrame is disregarded. Table 34 presents audio channels according to values of 3D\_CC.

[315] ACAT: [4 bits] indicates an audio channel allocation standard type provided by sources. Table 35 presents ACAT field values. Table 36 explains allocating a speaker position if ACAT is established as 0x01 (10.2 channels). Similarly, Tables 37 and 38 include information for 22.2 channels and 30.2 channels.

[316] 3D\_CA: [8 bits] indicates the allocaiton of channel/speaker for 3D audio. Further explanations are illustrated in Tables 36 to 38. 3D\_CA field is not valid for an IEC 61937 compression audio stream.

[317] Table 34 - 3D\_CC Field

[318]

3D_CC4	3D_CC3	3D_CC2	3D_CC1	3D_CC0	Audio Channel Count
0	0	0	0	0	Refer to Stream Header
0	0	0	0	1	2 channels
0	0	0	1	0	3 channels
0	0	0	1	1	4 channels
0	0	1	0	0	5 channels
0	0	1	0	1	6 channels
0	0	1	1	0	7 channels
0	0	1	1	1	8 channels
0	1	0	0	0	9 channels
0	1	0	0	1	10 channels
0	1	0	1	0	11 channels
0	1	0	1	1	12 channels
-	-	-	-	-	
1	1	1	1	1	32 channels

[319] Table 35 - Audio Channel Allocation Standard Type Field

[320]

ACAT3	ACAT2	ACAT1	ACAT0	Description
0	0	0	0	Reserved
0	0	0	1	Refer to 10 2 channels (TTA Standard)
0	0	1	0	Refer to 22 2 channels (SMPTE2036-2)
0	0	1	1	Refer to 30 2 channels (IEC62574/Ed 1)
0	1	0	0	reserved
1	1	1	1	

[321] Table 36 - 3D\_CA Field for 10.2 channels (ACAT=0x01)

[322]

3D_CA (binary)								3D_CA (hex)	Channel Number												
7	6	5	4	3	2	1	0		12	11	10	9	8	7	6	5	4	3	2	1	
0	0	0	0	0	0	0	0	0x00												FR	FL
0	0	0	0	0	0	0	1	0x01							RS	LS	FC	LFE1	FR	FL	
0	0	0	0	0	0	1	0	0x02					BR	BL	RS	LS	FC	LFE1	FR	FL	
0	0	0	0	0	0	1	1	0x03	TpFC	LFE2	TpFR	TpFL	BR	BL	RS	LS	FC	LFE1	FR	FL	
0	0	0	0	0	1	0	0	0x04	Reserved												
1	1	1	1	1	1	1	1	0xFF													

[323] Table 37 - 3D\_CA Field for 22.2 channels (ACAT=0x02)

[324]

3D_CA (binary)								3D_CA (hex)	Channel Number												
7	6	5	4	3	2	1	0		12	11	10	9	8	7	6	5	4	3	2	1	
0	0	0	0	0	0	0	0	0x00												FR	FL
0	0	0	0	0	0	0	1	0x01							SiR	SiL	FC	LFE1	FR	FL	
0	0	0	0	0	0	1	0	0x02					BR	BL	SiR	SiL	FC	LFE1	FR	FL	
0	0	0	0	0	0	1	1	0x03	TpFC	LFE2	TpFR	TpFL	BR	BL	SiR	SiL	FC	LFE1	FR	FL	
0	0	0	0	0	1	0	0	0x04	TpFC	LFE2	TpFR	TpFL	BR	BL	SiR	SiL	FC	LFE1	FR	FL	
0	0	0	0	0	1	0	1	0x05	Reserved												
1	1	1	1	1	1	1	1	0xFF													

[325]

3D_CA (binary)								3D_CA (hex)	Channel Number											
7	6	5	4	3	2	1	0		24	23	22	21	20	19	18	17	16	15	14	13
0	0	0	0	0	0	0	0	0x00	-	-	-	-	-	-	-	-	-	-	-	-
0	0	0	0	0	0	0	1	0x01	-	-	-	-	-	-	-	-	-	-	-	-
0	0	0	0	0	0	1	0	0x02	-	-	-	-	-	-	-	-	-	-	-	-
0	0	0	0	0	0	1	1	0x03	-	-	-	-	-	-	-	-	-	-	-	-
0	0	0	0	0	1	0	0	0x04	BtFC	BtFR	BtFL	TpC	TpSiR	TpSiL	TpBC	TpBR	TpBL	BC	FRC	FLC
0	0	0	0	0	1	0	1	0x05	Reserved											
1	1	1	1	1	1	1	1	0xFF												

[326] Table 38 - 3D\_CA Field for 30.2 channels (ACAT=0x03)

[327]

3D_CA (binary)								3D_CA (hex)	Channel Number											
7	6	5	4	3	2	1	0		12	11	10	9	8	7	6	5	4	3	2	1
0	0	0	0	0	0	0	0	0x00											FR	FL
0	0	0	0	0	0	0	1	0x01							SiR	SiL	FC	LFE1	FR	FL
0	0	0	0	0	0	1	0	0x02					BR	BL	SiR	SiL	FC	LFE1	FR	FL
0	0	0	0	0	0	1	1	0x03	TPFC	LFE2	TPFR	TPFL	BR	BL	SiR	SiL	FC	LFE1	FR	FL
0	0	0	0	0	1	0	0	0x04	TPFC	LFE2	TPFR	TPFL	BR	BL	SiR	SiL	FC	LFE1	FR	FL
0	0	0	0	0	1	0	1	0x05	TPFC	LFE2	TPFR	TPFL	BR	BL	SiR	SiL	FC	LFE1	FR	FL
0	0	0	0	0	1	1	0	0x06	Reserved											
1	1	1	1	1	1	1	1	0xFF												

[328]

3D_CA (binary)								3D_C A (hex)	Channel Number											
7	6	5	4	3	2	1	0		24	23	22	21	20	19	18	17	16	15	14	13
0	0	0	0	0	0	0	0	0x00	-	-	-	-	-	-	-	-	-	-	-	-
0	0	0	0	0	0	0	1	0x01	-	-	-	-	-	-	-	-	-	-	-	-
0	0	0	0	0	0	1	0	0x02	-	-	-	-	-	-	-	-	-	-	-	-
0	0	0	0	0	0	1	1	0x03	-	-	-	-	-	-	-	-	-	-	-	-
0	0	0	0	0	1	0	0	0x04	BiFC	BiFR	BiFL	TPC	TPSiR	TPSiL	TPBC	TPBR	TPBL	BC	FRC	FLC
0	0	0	0	0	1	0	1	0x05	BiFC	BiFR	BiFL	TPC	TPSiR	TPSiL	TPBC	TPBR	TPBL	BC	FRC	FLC
0	0	0	0	0	1	1	0	0x06	Reserved											
1	1	1	1	1	1	1	1	0xFF												

[329]

3D_CA (binary)								3D_CA (hex)	Channel Number							
7	6	5	4	3	2	1	0		32	31	30	29	28	27	26	25
0	0	0	0	0	0	0	0	0x00	-	-	-	-	-	-	-	-
0	0	0	0	0	0	0	1	0x01	-	-	-	-	-	-	-	-
0	0	0	0	0	0	1	0	0x02	-	-	-	-	-	-	-	-
0	0	0	0	0	0	1	1	0x03	-	-	-	-	-	-	-	-
0	0	0	0	0	1	0	0	0x04	-	-	-	-	-	-	-	-
0	0	0	0	0	1	0	1	0x05	TPRS	TPLS	RSd	LSd	RS	LS	FRW	FLW
0	0	0	0	0	1	1	0	0x06	Reserved							
1	1	1	1	1	1	1	1	0xFF								

[330]

Whenever transmitting an active 3D audio stream, a correct audio metadata packet may be transmitted at least once for two video fields. If a new 3D audio stream begins, or if changes are included in a 3D audio stream that can be indicated by an audio metadata packet and an audio InfoFrame, altered and correct audio metadata packets may be transmitted no later than one video frame following a first affected non-silent audio sample. Transmitting the altered and correct audio metadata packet may occur

right before transmitting the first affected audio sample. Audio metadata may be transmitted at any time including the horizontal blanking interval or the vertical blanking interval within the data island interval. If 3D audio is processed by streaming, the Sink disregards CC and CA fields included in the audio InfoFrame, and refers to 3D\_CC and 3D\_CA included in audio metadata.

[331] However, if transmitting the above audio metadata, traditional audio InfoFrame may still be utilized. In other words, if audio metadata are newly used to allocate channels for 3D audio, audio InfoFrame is utilized to allocate channels for 2D audio.

[332] Further, even though the above exemplary embodiments describe 10.2 channels, 22.2 channels, and 30.2 channels of ACAT, the technical art of the exemplary embodiments is not limited thereto and can be applied, for example, to less than 10.2 channels, more than 30.2 channels, and 10.2 to 30.2 channels.

[333] Second Exemplary Embodiment

[334] The second exemplary embodiment is different from the first exemplary embodiment in that alterations of audio InfoFrame defined in HDMI 1.4b may be considered according to the second exemplary embodiment. Table 39 presents audio InfoFrame in this case. The CC field indicates a channel count of transmitted audio, and the CA field indicates information of a channel/speaker allocation.

[335] Conventionally, a CC field is expressed with three bits. However, a second exemplary embodiment uses two additional bits of reserved area. Thus, channel count information may be indicated by utilizing five bits, CC0, CC1, CC2, CC3, CC4.

[336] Further, information of a channel/speaker allocation is added to a reserved area of CEA861-D, as shown above in Table 20. In contrast to the first exemplary embodiment, the second exemplary embodiment does not have an ACAT field.

[337] Table 39-1 - Modified Audio InfoFrame Packet Header

[338]

Byte/Bit#	7	6	5	4	3	2	1	0
HB0	Packet type = 0x84							
HB1	Version Number = 0x01							
HB2	0	0	0	Length = 10(0x0A)				

[339] Table 39-2 Audio infoframe Packet contents

[340]

Packet Byte #	CEA-861-D Byte #	7	6	5	4	3	2	1	0
PB0	n a	Checksum							
PB1	Data Byte 1	CT3	CT2	CT1	CT0	Rsvd	CC2	CC1	CC0
PB2	Data Byte 2	CC4	CC3		SF2	SF1	SF0	SS1	SS0
PB3	Data Byte 3	Format depends on coding type (i.e. CT0...CT3)							
PB4	Data Byte 4	CA7	CA6	CA5	CA4	CA3	CA2	CA1	CA0
PB5	Data Byte 5	DM_ INH	LSV3	LSV2	LSV1	LSV0	Rsvd(0)	LFEP BL1	LFEP BL0
PB6	Data Byte 6	Reserved(0)							
PB7	Data Byte 7	Reserved(0)							
PB8	Data Byte 8	Reserved(0)							
PB9	Data Byte 9	Reserved(0)							
PB10	Data Byte 10	Reserved(0)							
PB11- PB27	n a	Reserved(0)							

[341] Third Exemplary Embodiment

[342] A third exemplary embodiment expands the second exemplary embodiment and alters the audio InfoFrame defined in HDMI 1.4b. Table 40 presents an audio InfoFrame structure according to the third exemplary embodiment. Similar to the second exemplary embodiment, a CC field indicates a channel count of transmitted audio, and a CA field indicates information of a channel/speaker allocation.

[343] The third exemplary embodiment provides further expansion of a CA field while being basically similar to the second exemplary embodiment. One bit of a reserved area is established as channel\_extension bit. If channel\_extension=0, the CC# and CA# fields defined in CEA861-D are utilized. In other words, the third exemplary embodiment supports 2D audio mode. If channel\_extension=1, PB2[7:6] is used as expansion bit (CC4, CC3) of CC, and a reserved area of PB6 is used as a CA\_ext field. Expansion bits for 3D audio are used.

[344] In this case, similar to the second exemplary embodiment, conventional CC fields are expressed with three bits. However, the third exemplary embodiment further uses two bits of reserved areas. Thus, by utilizing five bits of CC0, CC1, CC2, CC3, CC4, channel count information is indicated.

[345] Further, a PB6 field may be added and used to CA bits (PB4). In a reserved area of CEA861-D as shown in Table 20 (or, CEA861-E as shown in Table 28), a definition of channel/speaker information for audio having 10.2 channels or more may be included. Extra tables may be defined in each standard. As a result, the CA field expands to 16 bits, and thus, multi-channel audio can be transmitted.

[346] Also, a new 8-bit field may be defined and used by substituting a field with a traditional CA field, which is different from the above description. For instance, a new

CA bit can be defined using a PB6 field or a PB7 field.

[347] Table 40 - Modified Audio InfoFrame 2

[348] Table 40-1 Audio infoframe Pocket Header

[349]

Byte/Bit#	7	6	5	4	3	2	1	0
HB0	Packet type = 0x84							
HB1	Version Number = 0x01							
HB2	0	0	0	Length = 10(0x0A)				

[350] Table 40-2 Audio infoframe Pocket contents

[351]

Packet Byte #	CEA-861-D Byte #	7	6	5	4	3	2	1	0
PB0	n. a	Checksum							
PB1	Data Byte 1	CT3	CT2	CT1	CT0	Rsvd	CC2	CC1	CC0
PB2	Data Byte 2	CC4	CC3		SF2	SF1	SF0	SS1	SS0
PB3	Data Byte 3	Format depends on coding type (i.e. CT0...CT3)							
PB4	Data Byte 4	CA7	CA6	CA5	CA4	CA3	CA2	CA1	CA0
PB5	Data Byte 5	DM IN H	LSV3	LSV2	LSV1	LSV0	Rsvd(0)	LFEP BL1	LFEP BL0
PB6	Data Byte 6	CA ext							
PB7	Data Byte 7	Reserved(0)							
PB8	Data Byte 8	Reserved(0)							
PB9	Data Byte 9	Reserved(0)							
PB10	Data Byte 10	Reserved(0)							
PB11-PB27	n. a	Reserved(0)							

[352] Fourth Exemplary Embodiment

[353] A fourth exemplary embodiment combines the second exemplary embodiment and the third exemplary embodiment. According to the fourth exemplary embodiment, a conventional audio InfoFrame includes a 3D\_CH\_present field, a CA field of PB4, and a 3D\_CC field of PB6.

[354] The 3D\_CH\_present field performs the same function of channel\_extension as described above in the third exemplary embodiment. Thus, if 3D\_CH\_present=0, the CC# and CA# fields defined in CEA861-D are still utilized. In other words, the fourth exemplary embodiment supports a 2D audio mode. Also, 3D\_CH\_present=1, PB6[4:0] is used for expansion bits of CC (CC4, CC3, CC2, CC1, CC0), and a reserved area of PB4 uses a CA field which is similar to the second exemplary embodiment. Expansion bits for 3D audio are utilized. Similar to the second and third exemplary embodiments, an ACAT field is not defined. Other features which are not described particularly are the same as the features described above with respect to the first to third exemplary embodiments.

[355] Table 41 - Modified Audio InfoFrame 3

[356] Table 41-1 - Modified Audio InfoFrame Packet Header

[357]

Byte/Bit#	7	6	5	4	3	2	1	0
HB0	Packet type = 0x84							
HB1	Version Number = 0x01							
HB2	0	0	0	Length = 10(0x0A)				

[358] Table 41-2 - Modified Audio InfoFrame Packet Contents

[359]

Packet Byte #	CEA-861-D Byte #	7	6	5	4	3	2	1	0
PB0	n. a	Checksum							
PB1	Data Byte 1	CT3	CT2	CT1	CT0	3D_CH_present=1	CC2	CC1	CC0
PB2	Data Byte 2	Reserved (0)			SF2	SF1	SF0	SS1	SS0
PB3	Data Byte 3	Format depends on coding type (i.e. CT0...CT3)							
PB4	Data Byte 4	CA7	CA6	CA5	CA4	CA3	CA2	CA1	CA0
PB5	Data Byte 5	DM_IN_H	LSV3	LSV2	LSV1	LSV0	Rsvd(0)	LFEP BL1	LFEP BL0
PB6	Data Byte 6	Reserved (0)			3D_CC4	3D_CC3	3D_CC2	3D_C C1	3D_C C0
PB7	Data Byte 7	Reserved(0)							
PB8	Data Byte 8	Reserved(0)							
PB9	Data Byte 9	Reserved(0)							
PB10	Data Byte 10	Reserved(0)							
PB11-PB27	n. a	Reserved(0)							

[360] 2-2. InfoFrame for Multi-Stream Audio

[361] Regarding multi-stream audio, a new metadata packet may not be defined, and InfoFrame defined in HDMI 1.4b may be used. If a plurality of active audio streams are transmitted using a multi-stream audio sample packet, a correct audio InfoFrame can be transmitted at least once for two video fields. Audio InfoFrame may be used in describing audio features of every active audio stream.

[362] If a new audio stream begins and if changes are included in an audio stream that can be implemented by a plurality of new audio streams or audio InfoFrame, altered and correct audio InfoFrames may be transmitted no later than one video field following first effected non-silent audio sample. The transmission of the stream may be implemented right before transmitting the first affected audio sample. Regarding a one bit audio stream, an audio InfoFrame may be transmitted before the first affected sample.

[363] Alteration of InfoFrame

[364] In contrast to the above described exemplary embodiment, regarding the utilizing of a Stream\_ID (e.g., the 4th and 6th exemplary embodiments of a 3D audio sample packet, and the 2nd, 3rd, 5th, and 6th exemplary embodiments of a multi-stream audio sample packet), the Stream\_ID may be included in audio InfoFrame, as shown, for example, in Table 42 below.

[365] Referring to Table 42, the Stream\_ID indicates a stream ID of a current audio InfoFrame, and Stream\_Count indicates the number of total audio streams to be transmitted. According to the exemplary embodiment, instead of not using stream identifiers, a sample may be loaded and transmitted on four sub packet constituted of a multi-stream audio sample packet body, which does not alter an InfoFrame.

[366] Table 42 - Modified InfoFrame

[367] Table 42-1 Audio InfoFrame Packet Header

[368]

Byte/Bit#	7	6	5	4	3	2	1	0
HB0	Packet type = 0x34							
HB1	Version Number = 0x01							
HB2	0	0	0	Length = 10(0x0A)				

[369] Table 42-2 Audio InfoFrame Packet contents

[370]

Packet Byte #	CEA-861-D Byte #	7	6	5	4	3	2	1	0
PB0	n. a	Checksum							
PB1	Data Byte 1	CT3	CT2	CT1	CT0	3D_CH_present	CC2	CC1	CC0
PB2	Data Byte 2	Reserved (0)			SF2	SF1	SF0	SS1	SS0
PB3	Data Byte 3	Format depends on coding type (i.e. CT0...CT3)							
PB4	Data Byte 4	CA7	CA6	CA5	CA4	CA3	CA2	CA1	CA0
PB5	Data Byte 5	DM_IN_H	LSV3	LSV2	LSV1	LSV0	Rsvd(0)	LFEP BL1	LFEP BL0
PB6	Data Byte 6	Reserved (0)			3D_CC4	3D_CC3	3D_CC2	3D_C C1	3D_C C0
PB7	Data Byte 7	Reserved(0)				Stream_count-1		Stream_ID	
PB8	Data Byte 8	Reserved(0)							
PB9	Data Byte 9	Reserved(0)							
PB10	Data Byte 10	Reserved(0)							
PB11-PB27	n. a	Reserved(0)							

[371] 3-1. EDID for 3D Audio

[372] Audio features of 3D audio and information of allocating speakers may be included in EDID by utilizing at least one of the operations of 1) altering conventional short audio descriptors and speaker allocation data blocks, 2) defining new data blocks in a reserved area for audio-related blocks on the extended tag codes, and 3) defining one new data block in a reserved area for an HDMI audio data block on the extended tag codes.

[373] For instance, EDID data blocks described in CEA-861-F (D or E) may be utilized to indicate both sink audio features and speaker allocation support. Sink audio features and speaker allocation support are indicated by serial short audio descriptors positioned on a data block collection of a CEA extension. Such data include an audio encoding list supported by Sink and parameters related to encoding, such as channel numbers to support formats. Speaker allocation descriptors may be included on a data block collection, and requested by Sink which support multi-channel (up to 8 channels) L-PCM for 2D audio or multi-channel (up to 8 channels) one bit audio.

[374] First Exemplary Embodiment

[375] If Sink supports transmitting multi-stream audio and/or 3D audio, an HDMI audio data block having an extended tag code 18 may be utilized in indicating 3D audio

features, 3D speaker allocation information, and multi-stream audio features.

- [376] If Sink supports transmitting 3D audio, an HDMI audio data block includes at least one HDMI 3D audio descriptor (HDMI\_3D\_AD) having four bytes. Further, an HDMI audio data block may include one HDMI 3D speaker allocation descriptor (HDMI\_3D\_SAD) following a last HDMI 3D audio descriptor.
- [377] If Sink supports transmitting multi-stream audio while not supporting transmitting 3D audio, an HDMI audio data block may include at least one CEA short audio descriptor (CEA\_SAD) following three bytes. CEA short audio descriptors are indicated in CEA-861-F (D or E).
- [378] If Sink supports transmitting multi-stream audio and 3D audio, an HDMI audio data block may include at least one CEA short audio descriptor following HDMI 3D speaker allocation descriptors. Table 43 provides additional details according to exemplary embodiments.
- [379] The above HDMI 3D audio descriptors indicate supporting audio encoding defined in CEA-861-F (D or E). HDMI apparatuses may support a 3D audio format according to TTA (10.2ch), SMPTE2036-2 (22.2ch) or IEC62574 (30.2ch). Tables 45 to 49 provide further explanations. The tables are classified by an audio format code shown in Table 24 of CEA-861-F (D or E) and Table 26.
- [380] As described above, HDMI 3D speaker allocation descriptors may be included in an HDMI audio data block and requested by Sink which supports 3D audio. The structure of HDMI 3D speaker allocation descriptors are shown in Table 50. Sink indicates audio capability by expressing speakers, e.g., a couple of speakers and establishes corresponding flags. HDMI 3D speaker allocation descriptors may have four bits of ACAT fields, which indicate an audio channel allocation standard type. Tables 50 to 52 provide further details. Further, CEA short audio descriptors may be included in an HDMI audio data block and requested by Sink which supports transmitting multi-stream audio. The above descriptors describe audio features of each audio stream. A maximum channel count may be limited to 2 channels in each audio stream; however, exemplary embodiments are not limited thereto, and according to exemplary embodiments, the channel count may be more than 2 channels in each audio stream.
- [381] Table 43 - HDMI Audio Data Block
- [382]

Byte/Bit #	7	6	5	4	3	2	1	0
1	Tag cod=7(Use Extended Tag)			L*=Length of following data block payload (in bytes)				
2	Extended Tag Code = 18 (0x12)							
3	NUM_HDMI_3D_AD(=X)			NUM_CEA_SAD(=Y)		Max_Stream_coun		
(4)~(7)	(if NUM_HDMI_3D_AD>0) HDMI_3D_AD_1							
...	...							
(3*X+1)~(3*X+4)	(if NUM_HDMI_3D_AD>0) HDMI_3D_AD_X							
(N*)~(n+3)	(if NUM_HDMI_3D_AD>0) HDMI_3D_SAD							
(N+4)~(N+6)	(if Max_Stream_Count-1>0 and NUM_CEA_SAD>0) CEA_SAD_1							
...	...							
(N+(3*y+1))~(N+(3*Y+3))	(if Max_Stream_Count-1>0 and NUM_CEA_SAD>0) CEA_SAD_Y							

[383] \* The length of the following data block payload (in bytes),  $2 + 4*X + 4 + 3*Y$

[384] \*\*  $3 + 4*X + 1$

[385] Each field of HDMI audio data block illustrated in Table 43 is described as follows.

[386] NUM\_HDMI\_3D\_AD [3 bits] indicates the number of HDMI 3D audio descriptors

[387] NUM\_CEA\_SAD [3 bits] indicates the number of CEA short audio descriptors.

[388] Max\_Stream\_Count-1 [2 bits] indicates the number = the number of transport stream - 1. Table 44 provides additional details.

[389] HDMI\_3D\_AD indicates an HDMI 3D audio descriptor.

[390] HDMI\_3D\_SAD indicates an HDMI 3D speaker allocation descriptor

[391] CEA\_SAD CEA indicates a CEA short audio descriptor.

[392] Table 44 - Max\_Stream\_Count - 1 field

[393]

Max_Stream_Count-1`	Description
00	Do not support Multi-Stream Audio
01	2 audio streams
10	3 audio streams
11	4 audio streams

[394] Table 45 - HDMI 3D Audio Descriptor for Audio Format Code = 1 (LPCM)

[395]

Byte/Bit#	7	6	5	4	3	2	1	0
1	0	0	0	0	Audio Format Code = 0001b			
2	0	0	0	Max Number of channels-1				
3	0	192 kHz	176.4kHz	96 kHz	88.2 kHz	48 kHz	44.1 kHz	32 kHz
4	0	0	0	0	0	24 bit	20 bit	16 bit

[396] Table 46 - HDMI 3D Audio Descriptor for Audio Format Codes 2 to 8

[397]

Byte/Bit#	7	6	5	4	3	2	1	0
1	0	0	0	0	Audio Format Code			
2	0	0	0	Max Number of channels-1				
3	0	192 kHz	176.4kHz z	96 kHz	88.2 kHz	48 kHz	44.1 kHz	32 kHz
4	Maximum bit rate divided by 8kHz							

[398] Table 47 - HDMI 3D Audio Descriptor for Audio Format Codes 9 to 13

[399]

Byte/Bit#	7	6	5	4	3	2	1	0
1	0	0	0	0	Audio Format Code			
2	0	0	0	Max Number of channels-1				
3	0	192 kHz	176.4kHz z	96 kHz	88.2 kHz	48 kHz	44.1 kHz	32 kHz
4	Audio Format Code dependent value							

[400] Table 48 - HDMI 3D Audio Descriptor for Audio Format Code 14 (WWA Pro)

[401]

Byte/Bit#	7	6	5	4	3	2	1	0
1	0	0	0	0	Audio Format Code=1110b			
2	0	0	0	Max Number of channels-1				
3	0	192 kHz	176.4kHz z	96 kHz	88.2 kHz	48 kHz	44.1 kHz	32 kHz
4	Reserved (0)					Profile		

[402] Table 49 - HDMI 3D Audio Descriptor for Audio Format Code 15

[403]

Byte/Bit#	7	6	5	4	3	2	1	0
1	0	0	0	0	Audio Format Code = 1111b			
2	0	0	0	Max Number of channels-1				
3	0	192 kHz	176.4kHz z	96 kHz	88.2 kHz	48 kHz	44.1 kHz	32 kHz
4	Audio Format Code Extension					0	0	0

[404] Table 50 - HDMI 3D Speaker Allocation Descriptor for 10.2 channels (TTA Standard) (Extension)

[405]

Byte/Bit #	7	6	5	4	3	2	1	0
PB1	FLW/FR W	BLC/BR C	FLC/FR C	BC	<b>BL/BR</b>	<b>FC</b>	<b>LFE1</b>	<b>FL/FR</b>
PB2	TpSiL/T pSiR	SiL/SiR	<b>TpBC</b>	<b>LFE2</b>	<b>LS/RS</b>	TpFC	TpC	<b>TpFL/Tp FR</b>
PB3	0	0	0	LS&LRd	TpLS/TpR S	BFL/Bt FR	BtFC	TpBL/TpB R
PB4	ACAT (=0X01)				0	0	0	0

[406] Bold bits in the above table indicate speakers which have already been allocated in accordance with 10.2 channels.

[407] Table 51 - HDMI 3D Speaker Allocation Descriptor for 22.2 channels

(SMPTE2036-2)

[408]

Byte/Bit #	7	6	5	4	3	2	1	0
PB1	<b>FLW/FRW</b>	<b>BLC/BR C</b>	<b>FLC/FR C</b>	<b>BC</b>	<b>BL/BR</b>	<b>FC</b>	<b>LFE1</b>	<b>FL/FR</b>
PB2	<b>Tp SIL/TP SIR</b>	<b>SIL/SIR</b>	<b>Tp BC</b>	<b>LFE2</b>	LS/RS	<b>Tp FC</b>	<b>Tp C</b>	<b>Tp FL/TP FR</b>
PB3	0	0	0	LSd/LRd	TpLS/TPRS	<b>BiFL/Bt FR</b>	<b>BtFC</b>	<b>Tp BL/TP BR</b>
PB4	ACAT (=0XD2)				0	0	0	0

[409]

Bold bits in the above table are speakers which have already been allocated in accordance with 22.2 channels.

[410]

Table 52 - HDMI 3D Speaker Allocation Descriptor for 30.2 channels (IEC62574/Ed. 1)

[411]

Byte/Bit #	7	6	5	4	3	2	1	0
PB1	<b>FLW/FRW</b>	<b>BLC/BR C</b>	<b>FLC/FR C</b>	<b>BC</b>	<b>BL/BR</b>	<b>FC</b>	<b>LFE1</b>	<b>FL/FR</b>
PB2	<b>Tp SIL/TP SIR</b>	<b>SIL/SIR</b>	<b>Tp BC</b>	<b>LFE2</b>	LS/RS	<b>Tp FC</b>	<b>Tp C</b>	<b>Tp FL/TP FR</b>
PB3	0	0	0	LSd/LRd	TpLS/TPRS	<b>BiFL/Bt FR</b>	<b>BtFC</b>	<b>Tp BL/TP BR</b>
PB4	ACAT (=0XD3)				0	0	0	0

[412]

Bold bits in the above table are speakers which have already been allocated in accordance with 30.2 channels.

[413]

Although the first exemplary embodiment describes speaker allocation of multi-channel 3D audio speakers with three bytes, this is merely exemplary only. 3D audio data having 30.2 channels or more may need more speaker allocation information than the information described above with respect to this exemplary embodiment. In this case, 3D speaker allocation descriptors may use more than four bytes to indicate speaker allocation.

[414]

Table 53 - Audio Channel Allocation Type (ACAT) Field

[415]

ACAT3	ACAT2	ACAT1	ACAT0	Description
0	0	0	0	Reserved
0	0	0	1	Refer to 10 2 channels (TTA Standard)
0	0	1	0	Refer to 22 2 channels (SMPTE2036-2)
0	0	1	1	Refer to 30 2 channels (IEC62574/Ed 1)
0	1	0	0	Reserved
1	1	1	1	

[416]

Reserved bits in ACAT fields may be allocated and utilized in various channel types,

e.g., Dolby, USC or ITU-R format to be standardized, according to the needs of manufacturers.

[417] Second Exemplary Embodiment

[418] A second exemplary embodiment is different from the first exemplary embodiment in that the second exemplary embodiment alters an audio data block. Specifically, a reserved area of CEA short audio descriptors may be used to expand and indicate a maximum number of channels. For instance, referring to Table 54 below, a maximum number of channels may be expanded by utilizing Byte1[7] and Byte2[7]. By this expansion, 3D audio can be indicated. CEA short audio descriptors may have a different field area according to an audio format.

[419] Table 54-1 CEA Short Audio Descriptor for Audio Code=1 (LPCM)

[420]

		Bits								
Byte#	7	6	5	4	3	2	1	0		
1	<b>F17=0</b>	Audio Format Code = 0001					Max Number of channels - 1			
2	<b>F27=0</b>	192 kHz	176.4 kHz	96 kHz	88.2 kHz	48 kHz	44.1 kHz	32 kHz		
3	<b>F37=0</b>	<b>F36=0</b>	<b>F35=0</b>	<b>F34=0</b>	<b>F33=0</b>	24 bit	20 bit	16 bit		

[421] Table 54-2 CEA Short Audio Descriptor for Audio Codes 2 to 8

[422]

		Bits								
Byte#	7	6	5	4	3	2	1	0		
1	<b>F17=0</b>	Audio Format Code					<b>Max Number of channels - 1</b>			
2	<b>F27=0</b>	192 kHz	176.4 kHz	96 kHz	88.2 kHz	48 kHz	44.1 kHz	32 kHz		
3	Mainum bit rate divided by 8 kHz									

[423] Table 54-3 CEA Short Audio Descriptor for Audio Codes 9 to 15

[424]

		bits								
Byte#	7	6	5	4	3	2	1	0		
1	<b>F17=0</b>	Audio Format Code					<b>Max Number of channels - 1</b>			
2	<b>F27=0</b>	192 kHz	176.4 kHz	96 kHz	88.2 kHz	48 kHz	44.1 kHz	32 kHz		
3	[Default=0, unless Defined by Audio Codex Vendor]									

[425] Independently of the above described second exemplary embodiment, ACAT may be established by altering a speaker allocation data block. ACAT may be recognized using Byte3[7:4] in a reserved area of a speaker allocation data block payload, and a speaker allocation data block in each type may be defined as a new table. Placement of ACAT fields may be defined differently within a range of Byte2[7:3]~Byte3[7:0].

[426] Referring to Table 55 below, ACAT=0001 indicates 10.2 channels of TTA standard and ACAT=0010 indicates 22.2 channels.

[427] Table 55 - Speaker Allocation Data Block Payload

[428] Table 55 - Speaker Allocation Data Block Payload (Refer to CEA861-E)

[429]

		bits							
Byte#	7	6	5	4	3	2	1	0	
1	FLW/FRW	RLC/RRC	FLC/FRC	RC	RL/RR	FC	LFE	FL/FR	
2	F27=0	F26=0	F25=0	F24=0	F23=0	FCH	TC	FLH/FRH	
3	F37=0	F36=0	F35=0	F34=0	F33=0	F32=0	F31=0	F30=0	

[430] Table 55-1 ACAT Field

[431]

ACAT	description
0000	Refer to CEA861-D(E,F)
0001	Refer to 10.2 channel (TTA Standard)
0010	Refer to 22.2 channel (SMPTE2036-2)
0011~1111	Reserved
0011~1111	Reserved

[432] Table 55-2 Speaker Allocation Data Block Payload (for 22.2 channel)

[433]

Byte#/bit	7	6	5	4	3	2	1	0
1	LFE2	SIL/SIR	FLC/FLR	BC	BL/BR	FC	LFE1	FL/FR
2	BtFC	BtFL/BtFR	TpBC	TpSIL/TpSIR	TpBL/TpBR	TpC	TpFC	TpFL/TpFR
3	ACAT = 0010b				0	0	0	0

[434] Table 55-3 Speaker Allocation Data Block Payload (for 10.2 channel)

[435]

Byte#/bit	7	6	5	4	3	2	1	0
1	CH	LC/RC	LB/RB	LS/RS	LFE2	LFE1	C	L/R
2	0	0	0	0	0	0	0	0
3	ACAT = 0010b				0	0	0	0

[436] Speaker allocation data blocks can be defined differently according to manufacturers. Manufacturers may consider enhancement of compatibility using common speaker allocation. Table 56 below presents an SMPTE2036-2 standard of 3D audio having 22.2 channels. Bold bits refer to common speaker allocations of several manufacturers.

[437] Table 56 - Speaker Allocation Data Block Payload 2 (Refer to CEA861-E)

[438]

Byte#	Bits							
	7	6	5	4	3	2	1	0
1	FLW/FRW	RLC/RRC	FLC/FRC	RC	RL/RR	FC	LFE	FL/FR
2	F27=0	F26=0	F25=0	F24=0	F23=0	FCH	TC	FLH/FRH
3	F37=0	F36=0	F35=0	F34=0	F33=0	F32=0	F31=0	F30=0

[439] Table 56-1 ACAT Field

[440]

ACAT	Description
0000	Refer to CEA861-D(E,F)
0001	Refer to 10.2 channel (TTA Standard)
0010	Refer to 22.2 channel (SMPTE2036-2)
0011~1111	Reserved

[441] Table 56-2 Speaker Allocation Data Block Payload (for 22.2 channel)

[442]

Byte#/bit	7	6	5	4	3	2	1	0
1	FLW/FRW	RLC/RRC	<b>FLC/FRC</b>	<b>RC</b>	<b>RL/RR</b>	<b>FC</b>	<b>LFE</b>	<b>FL/FR</b>
2	<b>TPBC</b>	<b>TPSIL/TPSIR</b>	<b>TPBL/TPBR</b>	<b>LFE2</b>	<b>SIL/SIR</b>	<b>FCH</b>	<b>TC</b>	<b>FLH/FRH</b>
3	ACAT = 0010b				0	0	<b>BtFC</b>	<b>BtFL/BtFR</b>

[443] Table 56-3 Speaker Allocation Data Block Payload (for 10.2 channel)

[444]

Byte#/bit	7	6	5	4	3	2	1	0
1	FLW/FRW	<b>RLC/RRC (LB/RB)</b>	FLC/FRC	RC	<b>RL/RR (LS/RS)</b>	FC	LFE	<b>FL/FR</b>
2	TPBC	TPSIL/TPSIR	TPBL/TPBR	<b>LFE2</b>	SIL/SIR	FCH	<b>TC</b>	<b>FLH/FRH</b>
3	ACAT = 0010b				0	0	BitFC	BitFL/BitFR

[445] In the above described exemplary embodiment of a speaker allocation data block payload, classification of each type, e.g., 10.2 channels (TTA), 22.2 channels (SMPTE2036-2), and 13.1 channels (Dolby), may be determined by referring to a position and sort of bits set in a speaker allocation data payload in sources without defining ACAT fields separately. The operation of determining a classification of a type can be performed because the number of channels may be found with an altered audio data block.

[446] Third Exemplary Embodiment

[447] A third exemplary embodiment does not define an HDMI audio data block and newly defines an extended speaker allocation data block type of an extended tag code in EDID. The size of a new data block can be 32 bytes at maximum. Table 57 illustrates an example of four bytes. The size of ACAT may be altered and defined according to needs of a user or manufacturer.

[448] ACAT is implemented by utilizing a reserved area (Byte3[7:4],) and a speaker allocation data block in each type may be defined. Payload may be formed in the same fashion as the above described exemplary embodiment. Further, ACAT fields may be placed in different areas other than the above reserved area.

[449] Reserved bits of ACAT fields may be allocated and utilized in various channel types, e.g., Dolby, USC, or ITU-R formats to be standardized, according to manufacturers.

[450] Table 57 - Modified Speaker Allocation Data Block

[451]

Extended Tag Codes	Type of Data Block
0	Video Capability Data Block
1	Vendor-Specific Video Data Block
2	Reserved for VESA Video Display Device Information Data Block
3	Reserved for VESA Video Data Block
4	Reserved for HDMI Video Data Block
5	Colorimetry Data Block
6...15	Reserved for video-related blocks
16	CEA Miscellaneous Audio Fields
17	Vendor-Specific Audio Data Block
18	Reserved for HDMI Audio Data Block
19	<b>Extended Speaker Allocation Data Block</b>
20...31	Reserved for audio-related blocks
32...255	Reserved for general

[452] Table 57-1 - ACAT Description

[453]

ACAT	description
0000	CEA861-D(E,F)
0001	10.2 channel (TTA Standard)
0010	22.2 channel (SMPTE2036-2)
0011~1111	Reserved

[454] Table 57-2 - Extended Speaker Allocation Data Block Payload(for 10.2channel)

[455]

Byte#/bit	7	6	5	4	3	2	1	0
1	FLW/FRW	RLC/RRC	FLC/FRC	RC	RL/RR	FC	LFE	FL/FR
2	TPBC	TPSIL/TPSIR	TPBL/TPBR	LFE2	SIL/SIR	FCH	TC	FLH/FRH
3	0	0	0	LSd/RSd	LS/RS	TPLS/TPRS	BtFC	BtFL/BtFR
4	ACAT = 0001b				0	0	0	0

[456] Table 57-3 - Extended Speaker Allocation Data Block Payload(for 22.2channel)

[457]

Byte#/bit	7	6	5	4	3	2	1	0
1	FLW/FRW	RLC/RRC	FLC/FRC	RC	RL/RR	FC	LFE	FL/FR
2	TPBC	TPSIL/TPSIR	TPBL/TPBR	LFE2	SIL/SIR	FCH	TC	FLH/FRH
3	0	0	0	LSd/RSd	LS/RS	TPLS/TPRS	BtFC	BtFL/BtFR
4	ACAT = 0010b				0	0	0	0

[458] Table 57-4 - Extended Speaker Allocation Data Block Payload(for 30.2channel)

[459]

Byte#/bit	7	6	5	4	3	2	1	0
1	FLW/FRW	RLC/RRC	FLC/FRC	RC	RL/RR	FC	LFE	FL/FR
2	TPBC	TPSIL/TPSIR	TPBL/TPBR	LFE2	SIL/SIR	FCH	TC	FLH/FRH
3	0	0	0	LSd/RSd	LS/RS	TPLS/TPRS	BtFC	BtFL/BtFR
4	ACAT = 0011b				0	0	0	0

[460] Fourth Exemplary Embodiment

[461] A fourth exemplary embodiment is similar to the third exemplary embodiment, however, has a difference in that, according to the fourth exemplary embodiment, a data block in each speaker allocation standard type, e.g., 10.2 channels (TTA), 22.2 channels (NHK), 13.1 channels (Dolby), is defined and a data block in each type is added to an extended tag code.

[462] For instance, data block tag code 19 indicates a speaker allocation data block for TTA 10.2 channels, data block tag code 20 indicates a speaker allocation data block for NHK 22.2 channels, and data block tag code 21 indicates a speaker allocation data block for Dolby 13.1 channels.

[463] Table 58 - Modified Speaker Allocation Data Block

[464]

Extended Tag Codes	Type of Data Block
0	Video Capability Data Block
1	Vendor-Specific Video Data Block
2	Reserved for VESA Video Display Device Information Data Block
3	Reserved for VESA Video Data Block
4	Reserved for HDMI Video Data Block
5	Colorimetry Data Block
6...15	Reserved for video-related blocks
16	CEA Miscellaneous Audio Fields
17	Vendor -Specific Audio Data Block
18	Reserved for HDMI Audio Data Block
19	<b>HDMI Speaker Allocation Data Block for 10.2ch(TTA)</b>
20	<b>HDMI Speaker Allocation Data Block for 22.2ch(NHK)</b>
21	<b>HDMI Speaker Allocation Data Block for 13.1ch(Dolby)</b>
22...31	Reserved for audio-related blocks
32...255	Reserved for general

[465] Table 58-1 Speaker Allocation Data Block payload(for multi-channel)

[466]

Byte#/bit	7	6	5	4	3	2	1	0
1	Pos.7	-	-	-	-	-	-	Pos.0
2	Pos.15	-	-	-	-	-	-	Pos.8
3	Pos.23	-	-	-	-	-	-	Pos.16
4	Pos.31	-	-	-	-	-	-	Pos.24

[467] Fifth Exemplary Embodiment

[468] A fifth exemplary embodiment defines an extended audio data block. An extended audio data block corresponds to extended tag codes. Further, an extended audio data block includes at least one extension CEA short audio descriptor. Each extension CEA short audio descriptor includes information regarding the number of channels. A size and format of each field may be the same as those of short audio descriptors in audio data blocks, however, the size and formats may also be defined differently.

[469] Table 59 - Extended Audio Data Block

[470]

Extended Tag Codes	Type of Data Block
0	Video Capability Data Block
1	Vendor-Specific Video Data Block
2	Reserved for VESA Video Display Device Information Data Block
3	Reserved for VESA Video Data Block
4	Reserved for HDMI Video Data Block
5	Colorimetry Data Block
6...15	Reserved for video-related blocks
16	CEA Miscellaneous Audio Fields
17	Vendor-Specific Audio Data Block
18	Reserved for HDMI Audio Data Block
19	<b>Extended Audio Data Block (includes one or more Extended Short Audio Descriptors)</b>
20	Extended Speaker Allocation Data Block
21	Multiple Audio Stream Data Block
22...31	Reserved for audio-related blocks
32...255	Reserved for general

[471] Table 59-1 Extended Audio Data Block

[472]

Byte#/bit	7	6	5	4	3	2	1	0
PB1	Tag Code=7 (USE Extended Tag)			Length = total number of extension audio bytes following this byte				
PB2	Extended data Block Tag Code =13h							
PB3	Extended CEA Short Audio Descriptor 1 (Refer to table 8*25)							
PB4								
PB5								
...	Extended CEA Short Audio Descriptor X (Refer to table 8*25)							
PB N-2								
PB N-1								
PB N								

[473] Table 59-2 Extended CEA Short Audio Descriptor

[474]

Byte#/bit	7	6	5	4	3	2	1	0
PB1	0	Uncompressed Audio Format Code = 00 or 01		Max number of channels - 1				
PB2	0	192kHz	176.4kHz	96kHz	88.2kHz	48kHz	44.1kHz	32kHz
PB3	0	0	0	0	0	24bit	20bit	16bit

[475] As described in the above table, extension CEA short audio descriptors may include uncompressed audio format code. Uncompressed audio format codes may be defined as follows.

[476] Table 60 - Uncompressed Audio Format Code

[477]

Uncompressed Audio Format Code	Description
00	FCM
01	One Bit Audio
10	Reserved
11	

[478] An extended speaker allocation data block may be defined to include values of extended tag codes. An extended speaker allocation data block may include an ACAT field as described in the table below. A reserved area may be used for expansion. Further, reserved bits may be allocated and utilized in various channel types, e.g., Dolby, USC, or ITU-R formats to be standardized, according to manufacturers.

[479] Table 61 - Extended Speaker Allocation Data Block

[480]

Extended Tag Codes	Type of Data Block
0	Video Capability Data Block
1	Vendor-Specific Video Data Block
2	Reserved for VESA Video Display Device Information Data Block
3	Reserved for VESA Video Data Block
4	Reserved for HDMI Video Data Block
5	Colorimetry Data Block
6...15	Reserved for video-related blocks
16	CEA Miscellaneous Audio Fields
17	Vendor-Specific Audio Data Block
18	Reserved for HDMI Audio Data Block
19	Extended Audio Data Block (includes one or more Extended Short Audio Descriptors)
<b>20</b>	<b>Extended Speaker Allocation Data Block</b>
21	Multiple Audio Stream Data Block
22...31	Reserved for audio-related blocks
32...255	Reserved for general

[481] Table 61-1 Extended Speaker Allocation Data Block

[482]

Byte#/bit	7	6	5	4	3	2	1	0
PB1	Tag Code=7 (USE Extended Tag)			Length = total number of extension audio bytes following this byte (=5 byte)				
PB2	Extended data Block Tag Code =13h							
PB3	FLw/FRw	RLC/RRC	FLC/FRC	RC	RL/RR	FC	LFE1	FL/FR
PB4	TpBC	TpSIL/TpSIR	TpBL/TpBR	LFE2	SL/SiR	FCM	TC	FLH/FRH
PB5	0	0	0	LSd/LRd	LS/RS	TpLS/TpRS	BtFC	BtFL/BtFR
PB6	ACAT(Audio Channel Allocation Type)				0	0	0	0

[483] Table 61-2 ACAT Description

[484]

ACAT3	ACAT2	ACAT1	ACAT0	Description
0	0	0	0	Refer to CEA861-D(or E, F) Refer to 10.2 channels (TTA Standard) Refer to 22.2 channels (SMRTE 2036-2) Refer to 30.2 channels (IEC62574Ed 1)
0	0	0	1	
0	0	1	0	
0	0	1	1	
0	1	0	0	
1	1	1	1	Reserved

[485] In this exemplary embodiment, payloads of extended speaker allocation data blocks are illustrated in the table below. Shade areas are used to allocate speakers for each channel allocation type.

[486] Table 62 - Channel Allocation Compatibility

[487]

Byte#/bit	7	6	5	4	3	2	1	0
PB1	<b>FLW/FR W</b>	<b>RLC/RRC</b>	<b>FLC/FRC</b>	<b>RC</b>	<b>RL/RR</b>	<b>FC</b>	<b>LFE1</b>	<b>FL/FR</b>
PB2	<b>TPBC</b>	<b>TPSIL/TPSI R</b>	<b>TPBL/TPB R</b>	<b>LFE2</b>	<b>SIL/SIR</b>	<b>FCH</b>	<b>TC</b>	<b>FLH/FR H</b>
PB3	0	0	0	LSd/LRd	LS/RS	TPLS/TPR S	BTFC	BtFL/BtF R
PB4	ACAT(Audio channel Allocation Type)				0	0	0	0

[488]

Byte#/bit	7	6	5	4	3	2	1	0
PB1	<b>FLW/FR W</b>	<b>RLC/RRC</b>	<b>FLC/FRC</b>	<b>RC</b>	<b>RL/RR</b>	<b>FC</b>	<b>LFE1</b>	<b>FL/FR</b>
PB2	<b>TPBC</b>	<b>TPSIL/TPSI R</b>	<b>TPBL/TPB R</b>	<b>LFE2</b>	<b>SIL/SIR</b>	<b>FCH</b>	<b>TC</b>	<b>FLH/FR H</b>
PB3	0	0	0	LSd/LRd	LS/RS	TPLS/TPR S	BTFC	BtFL/BtF R
PB4	ACAT(Audio channel Allocation Type)				0	0	0	0

[489]

Byte#/bit	7	6	5	4	3	2	1	0
PB1	<b>FLW/FR W</b>	<b>RLC/RRC</b>	<b>FLC/FRC</b>	<b>RC</b>	<b>RL/RR</b>	<b>FC</b>	<b>LFE1</b>	<b>FL/FR</b>
PB2	<b>TPBC</b>	<b>TPSIL/TPSI R</b>	<b>TPBL/TPB R</b>	<b>LFE2</b>	<b>SIL/SIR</b>	<b>FCH</b>	<b>TC</b>	<b>FLH/FR H</b>
PB3	0	0	0	LSd/LRd	LS/RS	TPLS/TPR S	BTFC	BtFL/BtF R
PB4	ACAT(Audio channel Allocation Type)				0	0	0	0

[490]

Byte#/bit	7	6	5	4	3	2	1	0
PB1	<b>FLW/FR W</b>	<b>RLC/RRC</b>	<b>FLC/FRC</b>	<b>RC</b>	<b>RL/RR</b>	<b>FC</b>	<b>LFE1</b>	<b>FL/FR</b>
PB2	<b>TPBC</b>	<b>TPSIL/TPSI R</b>	<b>TPBL/TPB R</b>	<b>LFE2</b>	<b>SIL/SIR</b>	<b>FCH</b>	<b>TC</b>	<b>FLH/FR H</b>
PB3	0	0	0	LSd/LRd	LS/RS	TPLS/TPR S	BTFC	BtFL/BtF R
PB4	ACAT(Audio channel Allocation Type)				0	0	0	0

[491] EDID/CEC for New Speaker Position

[492] A speaker position data block to carry new speaker position information to sources may be defined. A data block includes coordinate values (x, y, z) of every speaker position and position angle values. Sources may be utilized in various processing operations, such as down-mixing or object audio coding, with the above information. Because values of extended tag codes in the table below are allocated according to one of the exemplary embodiments, speaker position data blocks can be defined with data blocks as defined above and utilized.

[493] Table 63 - Speaker Position Data Block

[494]

Extended Tag Codes	Type of Data Block
0	Video Capability Data Block
1	Vendor-Specific Video Data Block
2	Reserved for VESA Video Display Device Information Data Block
3	Reserved for VESA Video Data Block
4	Reserved for HDMI Video Data Block
5	Colorimetry Data Block
6...15	Reserved for video-related blocks
16	CEA Miscellaneous Audio Fields
17	Vendor -Specific Audio Data Block
18	Reserved for HDMI Audio Data Block
19	Reserved for audio-related blocks
20	<b>Speaker Position Data Block 1</b>
21	<b>Speaker Position Data Block 2</b>
22	<b>Speaker Position Data Block 3</b>
23	<b>Speaker Position Data Block 4</b>
...	...
31	Reserved for audio-related blocks
32...255	Reserved for general

[495] Speaker position data blocks can be defined as set forth in the table below. Byte [1] to Byte [5] store position information of one speaker. According to the same exemplary embodiment, Byte [6] to Byte [30] store speaker position information of other speakers. Byte 31 and Byte 32 are defined as reserved areas.

[496] If the above exemplary embodiment is used, one data block can carry position information of six speakers at a maximum. Thus, to respond to N channels, a total of (N/6) speaker position data blocks may be needed.

[497] Table 64 - Speaker Position Data Block

[498]

	7	6	5	4	3	2	1	0
1	height		<b>Speaker_id</b>					Ang8
2	Ang7	Ang6	Ang5	Ang4	Ang3	Ang2	Ang1	Ang0
3	Offset_x							
4	Offset_y							
5	Offset_z							
6~10	<b>2 speaker position data</b>							
11~15	<b>3th speaker position data</b>							
16~20	<b>4 speaker position data</b>							
21~25	<b>5 speaker position data</b>							
26~30	<b>6 speaker position data</b>							
31~32	reserved							

[499] Table 64-1 Speaker\_id field

[500]

Speaker_id	Description
00000	FL
00001	FR
00010~11111	...

[501] Transmitting Speaker Position Information using CEC

[502] FIG. 12 illustrates an operation of transmitting speaker position information using consumer electronic control (CEC) according to an exemplary embodiment.

[503] Referring to FIG. 12, if sources transmit a request for speaker positions to Sink, Sink responds with speaker position information.

[504] 3-1. EDID for 3D Audio

[505] A multi-stream audio data block may be newly defined in extended tag codes. A multi-stream audio data block includes a Max\_stream\_count-1 field and a CEA short audio descriptor area. Max\_stream\_count-1 indicates the number of transmitting stream. CEA short audio descriptors are more than 1, and may be defined by CEA861-D.

[506] Table 65 - Multi Stream Audio Data Block

[507]

Byte#/bit	7	6	5	4	3	2	1	0
1	Reserved						Max_stream_count-1	
2	CEA Short Audio Descriptor 1							
3								
4								
...								
N	CEA Short Audio Descriptor X							

[508] Table 65-1 CEA Data Block Tag Codes

[509]

Extended Tag Codes	Type of Data Block
0	Video Capability Data Block
1	Vendor-Specific Video Data Block
2	Reserved for VESA Video Display Device Information Data Block
3	Reserved for VESA Video Data Block
4	Reserved for HDMI Video Data Block
5	Colorimetry Data Block
6...15	Reserved for video-related blocks
16	CEA Miscellaneous Audio Fields
17	Vendor-Specific Audio Data Block
18	Reserved for HDMI Audio Data Block
19...	Reserved for audio-related blocks
<b>XX</b>	<b>Multiple Audio Stream Data Block</b>
..31	Reserved for audio-related blocks
32...255	Reserved for general

[510] According to exemplary embodiments, whether or not multi-stream video/audio is provided may be indicated in a vendor-specific data block. A multistream\_indicator field is used. If Sink supports multi-stream, multistream\_indicator=1. Also, a multistream\_indicator field may be defined in another area of a data block as well as HDMI VSDB.

[511] Table 66 - Vendor-specific Data Block

[512]

Byte#	7	6	5	4	3	2	1	0
0	Vendor-specific tag code(=3)			Length(=N)				
1	24-bit IEEE Registration (0x000c03)							
2								
3								
4	A				B			
5	C				D			
6	Supports_Alt	DC_40bit	DC_30bit	DC_30bit	DC_Y444	Rsvd(0)	RSCD(0)	DVI_Dual
7	Max_TMDS_Clock							
8	Latency_Fields_Present	I_Latency_Fields_Present	HDMI_Video_Present	Rsvd(0)	CNC3	CNC2	CNC1	CNC0
(9)	Video_Latency							
(10)	Audio_Latency							
(11)	Interacted_Video_Latency							
(12)	Interacted_Audio_Latency							
(13)	3D_present	3D_Multi_Present	Image_size		Rsvd(0)	Rsvd(0)	Multistream_indicator	
(14)	HDMI_VIC_LEN	HDMI_3D_LEN						
(15)	(if HDMI_VIC_LEN>0)							
	HDMI_VIC_1							
	...							
	HDMI_VIC_M							
	(if 3D_Multi_present 01 or 10)							
	3D_Structure_ALL_15.8							
	3D_Structure_ALL_7.0							
	(if 3D_Multi_present 10)							
	3D_MASK_7.0							
	3D_MASK_7.0							
	3D_VIC_1				3D_Structure_1			

[513] If multistream\_indicator is defined using more than 2 bits, various multi-streams can be recognized.

[514] Table 67 - Vendor-specific Data Block

[515]

Byte#	7	6	5	4	3	2	1	0
0	Vendor-specific tag code(=3)			Length(=N)				
1	24-bit IEEE Registration (0x000c03)							
2								
3								
4	A				B			
5	C				D			
6	Supports AI	DC_40bit	DC_30bit	DC_30bit	DC_Y444	Rsvd(0)	RSCD(0)	DVI_Dual
7	Max_TMDS_Clock							
8	Latency_Fields Present	I_Latency_Fields Present	HDMI_Video_Present	Rsvd(0)	CNC3	CNC2	CNC1	CNC0
(9)	Video_Latency							
(10)	Audio_Latency							
(11)	Interacted_Video_Latency							
(12)	Interacted_Audio_Latency							
(13)	3D_present	3D_Multi_Present	Image_size			Multistream mode		
(14)	HDMI_VIC_LEN		HDMI_3D_LEN					
(15)	(if HDMI_VIC_LEN>0)							
	HDMI_VIC_1							
...	...							
	HDMI_VIC_M							
	(if 3D_Multi_present 01 or 10)							
	3D_Structure_ALL_15.8							
	3D_Structure_ALL_7.0							
	(if 3D_Multi_present 10)							
	3D_MASK_7.0							
	3D_MASK_7.0							
	3D_VIC_1				3D_Structure_1			

[516] Second Exemplary Embodiment

[517] A second exemplary embodiment newly defines a multi audio stream data block using extended tag codes. A newly defined multi audio stream data block includes a CEA short audio descriptor area, lengths of audio stream, Max\_stream\_count field, and/or other information. Each field may be the same as those described in the above exemplary embodiments, and will not be further explained.

[518] Table 68 - Multi Audio Stream Data Block

Extended Tag Codes	Type of Data Block
0	Video Capability Data Block
1	Vendor-Specific Video Data Block
2	Reserved for VESA Video Display Device Information Data Block
3	Reserved for VESA Video Data Block
4	Reserved for HDMI Video Data Block
5	Colorimetry Data Block
6...15	Reserved for video-related blocks
16	CEA Miscellaneous Audio Fields
17	Vendor-Specific Audio Data Block
18	Reserved for HDMI Audio Data Block
19	Extended Audio Data Block (includes one or more Extended Short Audio Descriptors)
20	Extended Speaker Allocation Data Block
21	<b>Multiple Audio Stream Data Block</b>
22...31	Reserved for audio-related blocks
32...255	Reserved for general

[520] Table 68-1 Multiple Audio Stream Data Block

[521]

Byte#/bit	7	6	5	4	3	2	1	0
PB1	Tag Code=7 (USE Extended Tag)			Length = total number of extension audio bytes following this byte				
PB2	Extended data Block Tag Code =13h							
PB3	0	0	0	0	0	0	Max_Stream_count-1	
PB4	CEA Short Audio Descriptor 1							
PB5								
PB6								
...	-							
PB N-2	CEA Short Audio Descriptor 1 X							
PB N-1								
PB N								

[522] Third Exemplary Embodiment

[523] Meanwhile, similar to the first exemplary embodiment, another method of utilizing an HDMI audio data block may be considered.

[524] Extended tag codes are newly defined. Similar to the first exemplary embodiment, tag code 18 may be used to add an extended HDMI audio data block.

[525] The table below presents a structure of an extended HDMI audio data block. The extended HDMI audio data block according to a third exemplary embodiment includes an Extended CEA Short Audio Descriptor (ECSAD), Extended Speaker Allocation Descriptor (ESAD), and Multiple Audio Stream Descriptor (MASD).

[526] If a Sink apparatus supports a 3D audio function, ECSAD includes the same number of descriptors as the number of values of Num\_ECSAD fields. If a Sink apparatus supports 3D-audio-channel function and if the value of a Num\_ECSAD field is more than 0, ESAD includes one descriptor. If a Sink apparatus supports a multi-stream audio function, MASD includes the same number of descriptors as the number of values of Num\_MASD fields.

[527] Max\_stream\_count-1 field is defined as the maximum number of streams that a Sink apparatus can receive minus 1. Since multi-stream audio is transmitted with one audio sample packet, an audio stream in each view indicates the same audio features such as coding type and sampling frequency.

[528] Num\_MASD field defines the number of extended CEA short audio descriptors. Up to seven may be included. If the field is 0, it is indicated that a 3D audio function may not be supported.

[529] Num\_ECSAD field defines the number of multi stream audio descriptors included in the data block. Up to four may be included. If the field is 0, it is indicated that multi-stream audio may not be supported. If Max\_stream\_count-1 is not 0, at least one MASA should be defined. If ECSAD includes using a method defined with four bytes, six may be defined at maximum according to exemplary embodiments.

[530] Table 69 - Extended HDMI Audio Data Block

[531]

Byte#/bit	7	6	5	4	3	2	1	0
PB1	Tag Code=7 (USE Extended Tag)			Length = total number of extension audio bytes following this byte				
PB2	Extended data Block Tag Code =13h							
PB3	Max Stream Count-1		Num MASD			Num ECSAD		
PB4~PB6	(if Num_ECSAD(X)>0) Extended CEA Short Descriptor 1							
...								
PB(N-3)~ PB(N-1)	(if Num_ECSAD(X)>0) Extended CEA Short Descriptor X							
PB(N)~ PB(N+3)	(if Num_ECSAD(X)>0) Extended Speaker Allocation Descriptor							
PB(N+4)~ PB(N+6)	(if Max Stream_Count-1>0 and Num MASD(Y)>0) Multiple Audio Stream Descriptor 1							
...								
PB(L-1)~ PB(L+1)	(if Max Stream_Count-1>0 and Num MASD(Y)>0) Multiple Audio Stream Descriptor Y							

[532] X : The number of ECSAD

[533] Y: the number of MASD

[534] Table 69 - 1 Stream Count-1 field

[535]

MaxStream Count-1	Description
00	Do not support multiple audio stream
01	2 audio streams
10	3 audio streams
11	4 audio streams

[536] The above third embodiment may include alternative suggestions as follows.

[537] For instance, an extended HDMI audio data block may include only ECSAD, and other two ESAD and MASD may be defined using other extended tag codes.

[538] Two descriptors defined with other extended tag codes may be defined as one separate data block or as different data blocks from each other. In a field that PB3 defines within the above table, Max\_stream\_count-1 is included in a data block in which a multi stream audio descriptor is defined.

[539] In contrast to the above, an extended HDMI audio data block may include ECSAD and ESAD related with 3D audio and MASD may be defined using other extended tag codes.

[540] An ECSAD structure is described by referring to the table below, in which the ECSAD structure corresponds to the column in which the bold letters are written.

[541] Referring to the bottom left table, the descriptors may be selected from two coding types such as LPCM and DSD currently. Also, other uncompressed audio formats may be added using a reserved area of a UAFC field.

[542] The number of channels may be allocated with five bits, and up to 32 channels can be selected.

[543] Table 70-1 Extended HDMI Audio Data Block Structure

[544]

Byte#/bit	7	6	5	4	3	2	1	0
PB1	Tag Code=7 (USE Extended Tag)			Length = total number of extension audio bytes following this byte				
PB2	Extended data Block Tag Code =13h							
PB3	Max Stream Count-1		Num MASD			Num ECSAD		
PB4~PB6	(if Num_ECSAD(X)>0) <b>Extended CEA Short Descriptor 1</b>							
...								
PB(N-3)~ PB(N-1)	(if Num_ECSAD(X)>0) <b>Extended CEA Short Descriptor X</b>							
PB(N)~	(if Num_ECSAD(X)>0)							
PB(N+3)	Extended Speaker Allocation Descriptor							
PB(N+4)~	(if Max Stream_Count-1>0 and Num MASD(Y)>0)							
PB(N+6)	Multiple Audio Stream Descriptor 1							
...								
PB(L-1)~ PB(L+1)	(if Max Stream_Count-1>0 and Num MASD(Y)>0) Multiple Audio Stream Descriptor Y							

[545] Table 70-2 Uncompressed Audio Format Code field

[546]

UAFC(Uncompressed Audio Format Code)	Description
00	LPCM
01	DSD
10	Reserved
11	

[547] Table 70-3 Extended CEA Short Audio Descriptor

[548]

Byte/Bit#	7	6	5	4	3	2	1	0
PB1	0	UAFC		Max Number of channels - 1				
PB2	0	192 kHz	176.4 kHz	96 kHz	88.2 kHz	48 kHz	44.1 kHz	32 kHz
PB3	0	0	0	0	0	24bit	20bit	16bit

[549] Also, regarding the above method, additional features according to exemplary embodiments are as follows.

[550] The following table extends a total amount of descriptors to four bytes. Further, an audio format code is referred to from the table defined in CEA861-E. Thus, both compressed and uncompressed coding types defined in CEA861-E can be assigned.

[551] As a descriptor amount increases, the number of ECSAD that can be included in a data block is limited to 6 descriptors at a maximum. Also, the above exemplary embodiment may include 4 descriptors.

[552] Syntaxes of PB3 and PB4 are defined as the same as Bytes 2 and 3 of Tables 45 to 49 in CEA861-E according to alterations in audio format code type.

[553] Table 71-1 Extended HDMI Audio Data Block Structure

[554]

Byte#/bit	7	6	5	4	3	2	1	0
PB1	Tag Code=7 (USE Extended Tag)			Length = total number of extension audio bytes following this byte				
PB2	Extended data Block Tag Code =13h							
PB3	Max Stream Count-1		Num MASD			Num ECSAD		
PB4~PB6	(if Num_ECSAD(X)>0)							
<b>Extended CEA Short Descriptor 1</b>								
...								
PB(N-3)~PB(N-1)	(if Num_ECSAD(X)>0)							
<b>Extended CEA Short Descriptor X</b>								
PB(N)~PB(N+3)	(if Num_ECSAD(X)>0)							
<b>Extended Speaker Allocation Descriptor</b>								
PB(N+4)~PB(N+6)	(if Max Stream_Count-1>0 and Num MASD(Y)>0)							
<b>Multiple Audio Stream Descriptor 1</b>								
...								
PB(L-1)~PB(L+1)	(if Max Stream_Count-1>0 and Num MASD(Y)>0)							
<b>Multiple Audio Stream Descriptor Y</b>								

[555] Table 71-2 Extended CEA Short Audio Descriptor

[556]

Byte/Bit#	7	6	5	4	3	2	1	0
PB1	0	0	0	Max Number of channels - 1				
PB2	0	0	0	0	Audio Format Code			
PB3	0	192 kHz	176.4 kHz	96 kHz	88.2 kHz	48 kHz	44.1 kHz	32 kHz
PB4	0	0	0	0	0	24bit	20bit	16bit

[557] According to the third exemplary embodiment, the structure of ESAD is described.

[558] Bold letters of the table below indicate the structure of ESAD.

[559] Currently, ESAD may select speaker allocation information of up to 30.2 channels. However, using the reserved area of an ACAT field, another speaker placement format may be additionally included.

[560] Table 72 - Extended Speaker Allocation Descriptor

[561] Table 72-1 Extended HDMI Audio Block Structure

[562]

Byte#/bit	7	6	5	4	3	2	1	0
PB1	Tag Code=7 (USE Extended Tag)			Length = total number of extension audio bytes following this byte				
PB2	Extended data Block Tag Code =13h							
PB3	Max Stream Count-1		Num MASD			Num ECSAD		
PB4~PB6	(if Num_ECSAD(X)>0)							
<b>Extended CEA Short Descriptor 1</b>								
...								
PB(N-3)~PB(N-1)	(if Num_ECSAD(X)>0)							
<b>Extended CEA Short Descriptor X</b>								
PB(N)~PB(N+3)	<b>(if Num_ECSAD(X)&gt;0)</b>							
<b>Extended Speaker Allocation Descriptor</b>								
PB(N+4)~PB(N+6)	(if Max Stream_Count-1>0 and Num MASD(Y)>0)							
<b>Multiple Audio Stream Descriptor 1</b>								
...								
PB(L-1)~PB(L+1)	(if Max Stream_Count-1>0 and Num MASD(Y)>0)							
<b>Multiple Audio Stream Descriptor Y</b>								

[563] Table 72-2 Audio Channel Allocation Type filed

[564]

A C A T 3	A C A T 2	A C A T 1	A C A T 0	Description
0	0	0	0	Refer to CEA861-D(or E,F)
0	0	0	1	Refer to 10.2 channels(TTA Standard)
0	0	1	0	Refer to 22.2 channels(SMPTE2036-2)
0	0	1	1	Refer to 30.2 channels(IEC62574/Ed 1)
0	1	0	0	Reserved
1	1	1	1	...

[565] Table 72-3 Extended Speaker Allocation Descriptor

[566]

Byte#/bit	7	6	5	4	3	2	1	0
PB1	FLW/FRW	RLC/RRC	FLC/FRC	RC	RL/RR	FC	LFE1	FL/FR
PB2	TPBC	TPSIL/TPSIR	TPBL/TPBR	LFE2	SIL/SIR	FCH	TC	FLH/FRH
PB3	0	0	0	LSd/LRd	LS/RS	TPLS/TPR	BTFC	BTFL/BtFR
PB4	ACAT(Audio Channel Allocation Type)				0	0	0	0

[567] The table below indicates ESAD. Bold letters of each table are used to allocate a speaker of a corresponding channel allocation type.

[568] Table 73 - Extended Speaker Allocation Descriptors

[569]

Byte#/bit	7	6	5	4	3	2	1	0
PB1	<b>FLW/FRW</b>	<b>RLC/RRC</b>	<b>FLC/FRC</b>	<b>RC</b>	<b>RL/RR</b>	<b>FC</b>	<b>LFE1</b>	<b>FL/FR</b>
PB2	TPBC	TPSIL/TPSIR	TPBL/TPBR	LFE2	SIL/SIR	<b>FCH</b>	<b>TC</b>	<b>FLH/FRH</b>
PB3	0	0	0	LSd/LRd	LS/RS	TPLS/TPR	BTFC	BTFL/BtFR
PB4	ACAT(Audio Channel Allocation Type)				0	0	0	0

[570]

Byte#/bit	7	6	5	4	3	2	1	0
PB1	FLW/FRW	<b>RLC/RRC</b>	<b>FLC/FRC</b>	<b>RC</b>	<b>RL/RR</b>	<b>FC</b>	<b>LFE1</b>	<b>FL/FR</b>
PB2	TPBC	TPSIL/TPSIR	TPBL/TPBR	<b>LFE2</b>	SIL/SIR	FCH	<b>TC</b>	<b>FLH/FRH</b>
PB3	0	0	0	LSd/LRd	LS/RS	TPLS/TPR	BTFC	BTFL/BtFR
PB4	ACAT(Audio Channel Allocation Type)				0	0	0	0

[571]

Byte#/bit	7	6	5	4	3	2	1	0
PB1	FLW/FRW	RLC/RRC	<b>FLC/FRC</b>	<b>RC</b>	<b>RL/RR</b>	<b>FC</b>	<b>LFE1</b>	<b>FL/FR</b>
PB2	<b>TPBC</b>	<b>TPSIL/TPSIR</b>	<b>TPBL/TPBR</b>	<b>LFE2</b>	<b>SIL/SIR</b>	<b>FCH</b>	<b>TC</b>	<b>FLH/FRH</b>
PB3	0	0	0	LSd/LRd	LS/RS	TPLS/TPR	<b>BTFC</b>	<b>BTFL/BtFR</b>
PB4	ACAT(Audio Channel Allocation Type)				0	0	0	0

[572]

Byte#/bit	7	6	5	4	3	2	1	0
PB1	<b>FLW/FRW</b>	RLC/RRC	<b>FLC/FRC</b>	<b>RC</b>	<b>RL/RR</b>	<b>FC</b>	<b>LFE1</b>	<b>FL/FR</b>
PB2	<b>TPBC</b>	<b>TPSIL/TPSIR</b>	<b>TPBL/TPBR</b>	<b>LFE2</b>	<b>SIL/SIR</b>	<b>FCH</b>	<b>TC</b>	<b>FLH/FRH</b>
PB3	0	0	0	<b>LSd/LRd</b>	<b>LS/RS</b>	<b>TPLS/TPR</b>	<b>BTFC</b>	<b>BTFL/BtFR</b>
PB4	ACAT(Audio Channel Allocation Type)				0	0	0	0

[573] The structure of ESAD according to the third exemplary embodiment is explained below. Bold letters of the table indicate the structure of ESAD.

[574] A CEA short audio descriptor defined in CEA861-E is used as stated. Also, while including each field in CEA short audio descriptors, a new format partly changing/modifying the defined field placement or amount may be used. The descriptors may be

only included when transmitting multi-stream audio. If used, at least one of the descriptors is included.

[575] Table 74 - Multiple Audio Stream Descriptor

[576] Table 74-1 Extended HDMI Audio Data Block Structure

[577]

Byte#/bit	7	6	5	4	3	2	1	0
PB1	Tag Code=7 (USE Extended Tag)			Length = total number of extension audio bytes following this byte				
PB2	Extended data Block Tag Code =13h							
PB3	Max Stream Count-1		Num MASD			Num ECSAD		
PB4~PB7	(if Num_ECSAD(X)>0) Extended CEA Short Descriptor 1							
...								
PB(N-4)~PB(N-1)	(if Num_ECSAD(X)>0) Extended CEA Short Descriptor X							
PB(N)~PB(N+3)	(if Num_ECSAD(X)>0) Extended Speaker Allocation Descriptor							
PB(N+4)~PB(N+6)	(if Max Stream_Count-1>0 and Num MASD(Y)>0) Multiple Audio Stream Descriptor 1							
...								
PB(L-1)~PB(L+1)	(if Max Stream_Count-1>0 and Num MASD(Y)>0) Multiple Audio Stream Descriptor Y							

[578] Table 74-2 Multiple Audio Stream Descriptor

[579]

Byte#/bit	7	6	5	4	3	2	1	0
PB1	CEA Short Audio Descriptor for each Audio Format Code							
PB2								
PB3								

[580] The table below newly defines the structure of a multi stream audio descriptor. Instead of using CEA short audio descriptors as stated, new descriptors may be utilized.

[581] The number of channels in multi-stream audio is limited to 2. Thus, in these descriptors, an unnecessary channel count field is deleted and maximum number of stream -1 is defined as 2-bit. Max\_stream\_count-1 stated in PB3 of an Extended HDMI audio data block is defined as the maximum value of Max\_stream\_count-1 in each descriptor.

[582] Each table below indicates descriptors in each audio format code.

[583] Table 75 - Multiple Audio Stream Descriptor

[584] Table 75-1 Multiple Audio Stream Descriptor for Audio Format Code 1 (LPCM)

[585]

Byte/Bit#	7	6	5	4	3	2	1	0
PB1	0	Audio Format Code = 0001				0	Max Stream_Count-1	
PB2	0	192 kHz	176.4 kHz	96 kHz	88.2 kHz	48 kHz	44.1 kHz	32 kHz
PB3	0	0	0	0	0	24bit	20bit	16bit

[586] Table 75-2 Multiple Audio Stream Descriptor for Audio Format Code 2 to 8

[587]

Byte/Bit#	7	6	5	4	3	2	1	0	
PB1	0	Audio Format Code					0	Max Stream_Count-1	
PB2	0	192 kHz	176.4 kHz	96 kHz	88.2 kHz	48 kHz	44.1 kHz	32 kHz	
PB3	Maximum bit rate divided by 8kHz								

[588] Table 75-3 Multiple Audio Stream Descriptor for Audio Format Code 9 to 13

[589]

Byte/Bit#	7	6	5	4	3	2	1	0	
PB1	0	Audio Format Code					0	Max Stream_Count-1	
PB2	0	192 kHz	176.4 kHz	96 kHz	88.2 kHz	48 kHz	44.1 kHz	32 kHz	
PB3	Audio Format Code dependent value								

[590] Table 75-4 Multiple Audio Stream Descriptor for Audio Format Code 14 (WMA Pro)

[591]

Byte/Bit#	7	6	5	4	3	2	1	0	
PB1	0	Audio Format Code = 1110					0	Max Stream_Count-1	
PB2	0	192 kHz	176.4 kHz	96 kHz	88.2 kHz	48 kHz	44.1 kHz	32 kHz	
PB3	Reserved					Profile			

[592] Table 75-5 Multiple Audio Stream Descriptor for Audio Format Code 15 ( extension)

[593]

Byte/Bit#	7	6	5	4	3	2	1	0	
PB1	0	Audio Format Code = 1111					0	Max Stream_Count-1	
PB2	0	192 kHz	176.4 kHz	96 kHz	88.2 kHz	48 kHz	44.1 kHz	32 kHz	
PB3	Audio Format Code Extension					24 bit	20 bit	16 bit	

[594] 4-1. Application Scenario for 3D Audio and Multi-stream Audio

[595] In the following description, application scenarios for 3D audio and multi-stream audio according to the first exemplary embodiment are provided. The following exemplary embodiments show the capability of a Sink apparatus to transmit HDMI 2.0 source, 3D audio, and multi-stream audio.

[596] Scenario for 3D Audio

[597] FIG. 13 illustrates that a 3D audio sample is transmitted from the blu-ray player (BDP) to the TV. This exemplary embodiment assumes the following.

[598] A Source such as the BDP and Sink such as the TV are HDMI 2.0 compliant devices.

[599] The Source transmits an L-PCM 48 kHz 22.2 channel audio stream to the Sink.

[600] Sink receives L-PCM 48 kHz 22.2 channel audio sample, and transmits each audio stream to a corresponding speaker. Transmitted video format is 1080 p/60 Hz.

[601] The TV includes a CEA-861-F (D or E) compliant E-EDID data structure that can be accessed with the DDC. To support transmitting 3D audio, E-EDID includes an HDMI audio data block in addition to other necessary data blocks. The BDP receives an HDMI audio data block and recognizes 3D audio capability of the TV described in Table 76.

[602] Table 76 - Example of the HDMI Audio Data Block for 22.2 Channels

[603]

Byte/bit #	7	6	5	4	3	2	1	0
1	Tag Code=7 (Use Extended Tag)			L=10(1010b)				
2	Extended Tag Code = 18(0x12)							
3	NUM_HDMI_3D_AD=001b			NUM_CEA_SAD=000b			Max_Stream_Count1=00b	
4	0	0	0	0	Audio Format Code = 1			
5	0	0	0	Max Number of channels -1 = 23 (10111b)				
6	0	192 kHz (0)	176.4 kHz (0)	96 kHz (1)	88.2 kHz (1)	48 kHz (1)	44.1 kHz (1)	32 kHz (1)
7	0	0	0	0	0	24 bit	20 bit	16 bit
8	FLW/FRW (0)	BLC/BRC (0)	FLC/FRC (1)	BC (1)	BL/BR (1)	FC (1)	LFE1 (1)	FL/FR (1)
9	TpSIL/TpSIR (1)	SIL/SIR (1)	TpBC (1)	LFE2 (1)	LS/RS (0)	TpFC (1)	TpC (1)	TpFL/TpFR (1)
10	0	0	0	LSd/LRd (0)	TpLS/TpRS (0)	BitFL/BitFR (1)	BtFC (1)	TpBL/TpBR (1)
11	ACAT=2(0010b)				0	0	0	0

[604] Byte 1, 2, 3 indicate an HDMI audio data block header. NUM\_HDMI\_3D\_AD is established to be 1, which indicates transmitting 3D audio. NUM\_CEA\_SAD and Max\_stream\_count-1 are set to be 0 because the BDP does not handle multi-stream audio in this exemplary scenario.

[605] Byte 4, 5, 6, 7 constitute HDMI 3D audio descriptors describing 3D audio features of the TV. Audio format codes, maximum channel number -1, sampling frequency and sample size are defined.

[606] Byte 8, 9, 10, 11 constitute HDMI 3D allocation descriptors describing active speakers for 22.2 channels (SMPEG 2036-2).

[607] The BDP receives EDID from the TV and transmits an audio InfoFrame and an audio metadata packet to the TV. In this case, an audio metadata packet is used instead of an audio InfoFrame, which transmits channel count and channel/speaker allocation information.

[608] 3D\_CC and 3D\_CA included in an audio metadata packet describes channel count and channel/speaker allocation information for a 22.2 channel audio stream, respectively. Table 77 below presents an example of audio InfoFrame payload to transmit 22.2 channel audio. Table 78 presents an audio metadata packet payload to transmit 22.2 channel audio.

[609] Table 77 - Example of the Audio InfoFrame Payload for 22.2 Channels

[610]

Packet Byte#	7	6	5	4	3	2	1	0
PB0	Checksum							
PB1	CT3 (0)	CT2 (0)	CT1 (0)	CT0 (0)	Reserved (0)	CC2 (0)	CC1 (0)	CC0 (0)
PB2	Reserved (0)			SF2 (0)	SF1 (0)	SF0 (0)	SS1 (0)	SS0 (0)
PB3	Format depends on coding type (i.e CT0..CT3)							
PB4	CA7 (0)	CA6 (0)	CA5 (0)	CA4 (0)	CA3 (0)	CA2 (0)	CA1 (0)	CA0 (0)
PB5	DM_INH	LSV3	LSV2	LSV1	LSV0	Rsvd(0)	LFEP BL1	LFEP BL0
PB6	Reserved (0)							
PB7	Reserved (0)							
PB8	Reserved (0)							
PB9	Reserved (0)							
PB10	Reserved (0)							
PB11- PB27	Reserved (0)							

[611] Table 78 - Audio Metadata Packet payload

Byte/Bit#	7	6	5	4	3	2	1	0
PB0	Rsvd (0)	Rsvd (0)	Rsvd (0)	3D_CC4 (1)	3D_CC3 (0)	3D_CC2 (1)	3D_CC1 (1)	3D_CC0 (1)
PB1	Rsvd (0)	Rsvd (0)	Rsvd (0)	Rsvd (0)	ACAT = 0x02			
PB2	3D_CA7 (0)	3D_CA6 (0)	3D_CA5 (0)	3D_CA4 (0)	3D_CA3 (0)	3D_CA2 (1)	3D_CA1 (0)	3D_CA0 (0)
PB2..PB27	Reserved (0)							

[613] The BDP transmits 22.2 channel audio samples through 3D audio sample packets. Each 3D audio sample packet supports up to 8 audio channels, and thus, requires three consecutive 3D audio sample packets to transmit 22.2 channel audio samples. sample\_start is used in assigning a first 3D audio sample packet. In this exemplary embodiment, three 3D audio sample packets may be defined as stated in Tables 79 to 81.

[614] Table 79 - Example of First 3D Audio Sample Packet for 22.2 Channels

Byte/bit#	7	6	5	4	3	2	1	0
HB0	0	0	0	0	1	0	1	1
HB1	0	0	0	Sample_ Start (1)	Sample_ Present sp3 (1)	Sample_ Present sp2 (1)	Sample_ Present sp1 (1)	Sample_ Present sp0 (1)
HB2	B 3	B 2	B 1	B 0	Sample_fla t sp3(0)	Sample_f lat sp2(0)	Sample_f lat sp1 (0)	Sample_f lat sp0(0)
SB0~SB2	Channel 1 / Sample N							
SB3~SB5	Channel 2 / Sample N							
SB6	PCUV of Ch 2				PCUV of Ch 1			
SB7~SB9	Channel 3 / Sample N							
SB10~SB12	Channel 4 / Sample N							
SB13	PCUV of Ch 4				PCUV of Ch 3			
SB14~SB16	Channel 5 / Sample N							
SB17~SB19	Channel 6 / Sample N							
SB20	PCUV of Ch 6				PCUV of Ch 5			
SB21~SB23	Channel 7 / Sample N							
SB24~SB26	Channel 8 / Sample N							
SB27	PCUV of Ch 8				PCUV of Ch 7			

[616] Table 80 - Example of Second 3D Audio Sample Packet for 22.2 Channels

[617]

Byte/bit#	7	6	5	4	3	2	1	0
HB0	0	0	0	0	1	0	1	1
HB1	0	0	0	Sample_ Start (0)	Sample_ Present sp3 (1)	Sample_ Present sp2 (1)	Sample_ Present sp1 (1)	Sample_ Present sp0 (1)
HB2	B 3	B 2	B 1	B 0	Sample_flat sp3(0)	Sample_f lat sp2(0)	Sample_f lat sp1 (0)	Sample_f lat sp0(0)
SB0~SB2	Channel 9 / Sample N							
SB3~SB5	Channel 10 / Sample N							
SB6	PCUV of Ch 10				PCUV of Ch 9			
SB7~SB9	Channel 11 / Sample N							
SB10~SB12	Channel 12 / Sample N							
SB13	PCUV of Ch 12				PCUV of Ch 11			
SB14~SB16	Channel 13 / Sample N							
SB17~SB19	Channel 14 / Sample N							
SB20	PCUV of Ch 14				PCUV of Ch 13			
SB21~SB23	Channel 15 / Sample N							
SB24~SB26	Channel 16 / Sample N							
SB27	PCUV of Ch 16				PCUV of Ch 15			

[618] Table 81 - Example of Third 3D Audio Sample Packet for 22.2 Channels

[619]

Byte/bit#	7	6	5	4	3	2	1	0
HB0	0	0	0	0	1	0	1	1
HB1	0	0	0	Sample_ Start (0)	Sample_ Present sp3 (1)	Sample_ Present sp2 (1)	Sample_ Present sp1 (1)	Sample_ Present sp0 (1)
HB2	B 3	B 2	B 1	B 0	Sample_flat sp3(0)	Sample_f lat sp2(0)	Sample_f lat sp1 (0)	Sample_f lat sp0(0)
SB0~SB2	Channel 17 / Sample N							
SB3~SB5	Channel 18 / Sample N							
SB6	PCUV of Ch 18				PCUV of Ch 17			
SB7~SB9	Channel 19 / Sample N							
SB10~SB12	Channel 20 / Sample N							
SB13	PCUV of Ch 20				PCUV of Ch 19			
SB14~SB16	Channel 21 / Sample N							
SB17~SB19	Channel 22 / Sample N							
SB20	PCUV of Ch 22				PCUV of Ch 21			
SB21~SB23	Channel 23 / Sample N							
SB24~SB26	Channel 24 / Sample N							
SB27	PCUV of Ch 24				PCUV of Ch 23			

[620] 4-2. Example of Scenario for Multi-stream Audio

[621] FIG. 14 illustrates that multi-stream audio is transmitted from the BDP to the TV according to an exemplary embodiment. This exemplary embodiment assumes the following.

[622] A Source such as the BDP and a Sink such as the TV are HDMI 2.0 compliant devices.

[623] The Source/Sink enter into dual-view game mode.

[624] The Source transmits two audio streams of each view.

[625] The Sink may transmit two audio streams to two different headphones to each other.

[626] The transmitted video format is HDMI 3D 1080 p/60 Hz.

[627] The TV includes a CEA-861-F (D or E) compliant E-EDID data structure that can be accessed through DDC. To support multi-stream audio, E-EDID may have an HDMI audio data block in addition to other necessary blocks. The BDP receives an HDMI audio data block and recognizes a multi-stream audio capability of the TV as stated in

Table 76.

[628] Table 82 - Example of HDMI Audio Data Block for Two Audio Streams

[629]

Byte/bit #	7	6	5	4	3	2	1	0
1	Tag Code=7 (Use Extended Tag)			L=8(1010b)				
2	Extended Tag Code = 18(0x12)							
3	NUM_HDMI_3D_AD=000b		NUM_CEA_SAD=010b			Max_Stream_Count1=01b		
4	0	Audio Format Code=0001b				Max Number of channel 1 = 001b		
5	0	192 kHz (1)	176.4 kHz (1)	96 kHz (1)	88.2 kHz (1)	48 kHz (1)	44.1 kHz (1)	32 kHz (1)
6	0	0	0	0	0	24 bit	20 bit	16 bit
7	0	Audio Format Code=0110b				Max Number of channel 1 = 001b		
8	0	192 kHz (1)	176.4 kHz (1)	96 kHz (1)	88.2 kHz (1)	48 kHz (1)	44.1 kHz (1)	32 kHz (1)
9	Maximum bit rate divided by 8kHz							

[630] Byte 1, 2, 3 indicate HDMI audio data block headers. NUM\_CEA\_SAD is established to be 2 because the Sink supports two types of audio format codes for multi-stream audio. Max\_stream\_count-1 is established to be 1 because the Sink can handle two independent audio streams as described above. NUM\_HDMI\_3D\_AD is established to be 0 because the BDP can handle transmitting 3D audio in this exemplary scenario.

[631] Byte 4, 5, 6 constitute a first CEA short audio descriptor describing audio features. Regarding transmitting multi-stream audio, a maximum channel count is limited to be 2. Because of this, a maximum number of channels -1 is 1.

[632] Byte 7, 8, 9 indicates a second CEA short audio descriptor describing audio features. As stated above, a maximum number of channels -1 is 1. The BDP may transmit an audio InfoFrame to the TV after receiving EDID from the TV. Contrary to a 3D audio transmitting scenario, CC and CA are used in transmitting a channel count and channel/speaker allocation information, respectively. An audio metadata packet may not be utilized in transmitting multi-stream audio. Table 83 shows an example of audio InfoFrame payload to transmit two audio streams.

[633] Table 83 - Example of Audio InfoFrame Payload for Two Audio Streams

[634]

Packet Byte#	7	6	5	4	3	2	1	0
PB0	Checksum							
PB1	CT3 (0)	CT2 (0)	CT1 (0)	CT0 (0)	Reserved (0)	CC2 (0)	CC1 (0)	CC0 (0)
PB2	Reserved (0)			SF2 (0)	SF1 (0)	SF0 (0)	SS1 (0)	SS0 (0)
PB3	Format depends on coding type (i.e CT0..CT3)							
PB4	CA7 (0)	CA6 (0)	CA5 (0)	CA4 (0)	CA3 (0)	CA2 (0)	CA1 (0)	CA0 (0)
PB5	DM_INH	LSV3	LSV2	LSV1	LSV0	Rscd(0)	LFEP BL1	LFEP BL0
PB6	Reserved (0)							
PB7	Reserved (0)							
PB8	Reserved (0)							
PB9	Reserved (0)							
PB10	Reserved (0)							
PB11- PB27	Reserved (0)							

[635] The BDP transmits multi-stream audio sample packets having stereo audio samples for two independent audio streams. Thus, a first sub packet has a stereo audio sample from the first audio stream, and a second sub packet has a stereo audio sample from the second audio stream. In the exemplary embodiment, a multi-stream audio sample packet may be defined as shown in Table 84.

[636] Table 84 - Example of Multi-stream Audio Sample Packet for Two Audio Streams

[637]

Byte/bit#	7	6	5	4	3	2	1	0
HB0	0	0	0	0	1	0	1	1
HB1	0	0	0	0	Stream present sp3 (0)	Stream present sp2 (0)	Stream present sp1 (1)	Stream present sp0 (1)
HB2	B 3	B 2	B 1	B 0	Stream flat sp3(0)	Stream fl at sp2(0)	Stream fl at sp1 (0)	Stream fl at sp0(0)
SB0~SB2	Channel 1 / Sample N (Stream 0)							
SB3~SB5	Channel 2 / Sample N (Stream 0)							
SB6	PCUV of Ch 2 (Stream 0)				PCUV of Ch 1 (Stream 0)			
SB7~SB9	Channel 1 / Sample N (Stream 1)							
SB10~SB12	Channel 2 / Sample N (Stream 1)							
SB13	PCUV of Ch 2 (Stream 1)				PCUV of Ch 1 (Stream 1)			
SB14~SB16	Empty (0)							
SB17~SB19								
SB20								
SB21~SB23	Empty (0)							
SB24~SB26								
SB27								

[638] 3D Audio Speaker Replacement and Channel Allocation

[639] In the following description, speaker replacement and channel allocation for 3D audio channels are described.

[640] FIG. 15 illustrates speaker placement for 3D audio channels according to an exemplary embodiment.

[641] According to an exemplary embodiment described in Table 85, in case of an IEC 30.2 channel standard type, FL indicates a front left speaker, FR indicates a front right speaker, LFF1 indicates a low frequency effect 1 speaker, FC indicate a front center speaker, BL indicates a back left speaker, BR indicates a back right speaker, FLW indicates a front left wide speaker, FRW indicates a front right wide speaker, TpFL

indicates a top front left speaker, TpFR indicates a top front right speaker, BC indicates a back center speaker, LS indicates a left surround speaker, RS indicates a right surround speaker, LFE2 indicates a low frequency effect 2 speaker, FLC indicates a front left center speaker, FRC indicates a front right center speaker, TpFC indicates a top front center speaker, TpC indicates a top center speaker, SiL indicates a side left speaker, SiR indicates a side right speaker, TpBL indicates a top back left speaker, TpBR indicates a top back right speaker, TpSiL indicates a top side left speaker, TpSiR indicates a top side right speaker, BtFC indicates a bottom front center speaker, BtFL indicates a bottom front left speaker, BtFR indicates a bottom front right speaker, TpBC indicates a top back center speaker, TpLS indicates a top left surround speaker, TpRS indicates a top right surround speaker, LSd indicates a left surround direct speaker, and RSd indicates a right surround direct speaker.

[642] However, according to a standard type, speaker names may be different from each other. For instance, a front center speaker is written as FC in the above IEC standard, however, the TTA standard writes the front center speaker as C. Various speaker names other than those described in the table below may be used. The following table and description of FIG. 15 described one of the exemplary embodiments; speaker and channel allocation may be configured differently according to other exemplary embodiments.

[643] Different from 2D audio data, 3D audio data supported with multi-channel has common features in having different speakers from each other in top, center, and bottom of 3D spaces respectively. FIG. 15 illustrates an exemplary embodiment of speaker placement in an area.

[644] Table 85 - Audio Channel Description & Abbreviation Comparison  
(CEA/TTA/SMPTE/IEC)

[645]

Abbreviation				Description
CEA_861	TTA(10.2ch)	SMPTE (22.2ch)	IEC (30.2ch)	
FL	L	FL	FL	Front left
FR	R	FR	FR	Front right
LFE	LFE1	LFE1	LFE1	Low Frequency Effect 1
FC	C	FC	FC	Front center
RL	LB	BL	BL	Back Left
RR	RB	BR	BR	Back Right
FLW			FLW	Front Left Wide
FRW			FRW	Front Right Wide
FLH	LH	TpFL	TpFL	Top Front Left
FRH	RH	TpFR	TpFR	Top Front right
RC		BC	BC	Back Center
	LS		LS	Left Surround
	RS		RS	Right Surround
	LFE2	LFE2	LFE2	Low Frequency Effect 2
FLC		FLC	FLC	Front Left center
FRC		FRC	FRC	Front right Center
RLC				Rear Left Center
RRC				Rear Right Center
FCH		TpFC	TpFC	Top Front Center
TC		TpC	TpC	Top Center
		SiL	SiL	Side Left
		SiR	SiR	Side Right
		TpBL	TpBL	Top Back Left
		TpBR	TpBR	Top Back Right
		TpSiL	TpSiL	Top Side Left
		TpSiR	TpSiR	Top Side Right
		BtFC	BtFC	Bottom Front Center
		BtFL	BtFL	Bottom Front Left
		BtFR	BtFR	Bottom Front Right
	CH	TpBC	TpBC	Top Back Center
			TpLS	Top Left Surround
			TpRS	Top right Surround
			LSd	Left surround direct
			RSd	Right Surround direct

[646] 5. Data Transmitting Method and Data Receiving Method

[647] Hereinafter, a data transmitting method and a data receiving method complying with the above-described standards will be described with reference to FIGS. 16 to 19.

[648] FIGS. 16 to 19 are flowcharts illustrating data transmitting methods and data receiving methods according to various exemplary embodiments.

[649] First, referring to FIG. 16, a data transmitting method according to various exemplary embodiments includes generating a plurality of packets for multichannel audio sample data at operation S1610 and transmitting the plurality of packets generated to a data receiving apparatus at operation S1620. Each of the plurality of packets generated may include an identification field for identifying a position or an order thereof among the plurality of packets. Each operation has been described above

and thus repetitive description thereof will be omitted.

[650] Referring to FIG. 17, a data receiving method according to various exemplary embodiments includes receiving a plurality of packets for multichannel audio sample data transmitted from a data transmitting apparatus at operation S1710 and performing parsing on the plurality of packets received at operation S1720. Each of the plurality of received packets may include an identification field for identifying a position or an order thereof among the plurality of packets. Each operation has been described above and thus repetitive description thereof will be omitted.

[651] According to exemplary embodiments, the identification field may include a preset bit indicating whether or not the packet including the identification field is a starting packet of the multichannel audio sample data.

[652] Referring to FIG. 18, a data transmitting method according to various exemplary embodiments includes generating a packet including a plurality of sub packets at operation S1810 and transmitting the generated packet to a data receiving apparatus at operation S1820. Each of the plurality of sub packets includes audio data corresponding to content (e.g., any one unit of content) of a plurality of contents. Each operation has been described above and thus repetitive description thereof will be omitted.

[653] Referring to FIG. 19, a data receiving method according to various exemplary embodiments includes receiving a packet including a plurality of sub packets at operation S1910 and performing parsing on the received packet at operation S1920. Each operation has been described above and repetitive description thereof will be omitted.

[654] According to exemplary embodiments, each of the plurality of sub packets may include audio data corresponding to content (e.g., any one unit of content) among a plurality of contents.

[655] The foregoing exemplary embodiments and advantages are merely exemplary and are not to be construed as limiting the exemplary embodiments. The present teaching can be readily applied to other types of apparatuses. Also, the description of the exemplary embodiments is intended to be illustrative and not to limit the scope of the claims, and many alternatives, modifications, and variations will be apparent to those skilled in the art.

### **Mode for the Invention**

[656] -

## Claims

- [Claim 1] A data transmitting apparatus, comprising:  
a packet generator configured to generate a packet including a plurality of sub packets; and  
a transmitter configured to transmit the generated packet to a data receiving apparatus,  
wherein each of the plurality of sub packets includes audio data corresponding to content among a plurality of contents.
- [Claim 2] The data transmitting apparatus as claimed in claim 1, wherein each of the plurality of sub packets includes an identification field which represents whether the corresponding sub packet indicates content among the plurality of contents.
- [Claim 3] The data transmitting apparatus as claimed in claim 1, wherein the generated packet includes a header,  
wherein the header includes one of a stream present bit indicating whether or not each of the plurality of sub packets includes the audio data and a stream flat bit indicating whether or not the audio data included in each of the plurality of sub packets is effective data.
- [Claim 4] The data transmitting apparatus as claimed in claim 1, wherein each of the plurality of sub packets stores a portion of the audio data.
- [Claim 5] The data transmitting apparatus as claimed in claim 1, wherein the audio data includes audio signals of two channels or more.
- [Claim 6] The data transmitting apparatus as claimed in claim 1, wherein the audio data complies with an international electrotechnical commission (IEC) 60958 format.
- [Claim 7] A data receiving apparatus, comprising:  
a receiver configured to receive a packet including a plurality of sub packets; and  
a packet parsing unit configured to perform parsing on the received packet,  
wherein each of the plurality of sub packets includes audio data corresponding to content among a plurality of contents.
- [Claim 8] The data receiving apparatus as claimed in claim 7, wherein the received packet includes a header,  
wherein the header includes one of a stream present bit indicating whether or not each of the plurality of sub packets includes the audio data and a stream flat bit indicating whether or not the audio data

- included in each of the plurality of sub packets is effective data.
- [Claim 9] The data receiving apparatus as claimed in claim 7, wherein each of the plurality of sub packets stores a portion of the audio data.
- [Claim 10] The data receiving apparatus as claimed in claim 7, wherein the audio data includes audio signals of two channels or more.
- [Claim 11] The data receiving apparatus as claimed in claim 7, wherein the audio data complies with an international electrotechnical commission (IEC) 60958 format.
- [Claim 12] A data transmitting method, comprising:  
generating a packet including a plurality of sub packets; and  
transmitting the generated packet to a data receiving apparatus,  
wherein each of the plurality of sub packets includes audio data corresponding to content among a plurality of contents.
- [Claim 13] The data transmitting method as claimed in claim 12, wherein each of the plurality of sub packets further includes an identification field which represents whether the corresponding sub packet indicates content among the plurality of contents.
- [Claim 14] The data transmitting method as claimed in claim 12, wherein the generated packet includes a header,  
wherein the header includes one of a stream present bit indicating whether or not each of the plurality of sub packets includes the audio data and a stream flat bit indicating whether or not the audio data included in each of the plurality of sub packets is effective data.
- [Claim 15] The data transmitting method as claimed in claim 12, wherein each of the plurality of sub packets stores a portion of the audio data.

[Fig. 1]

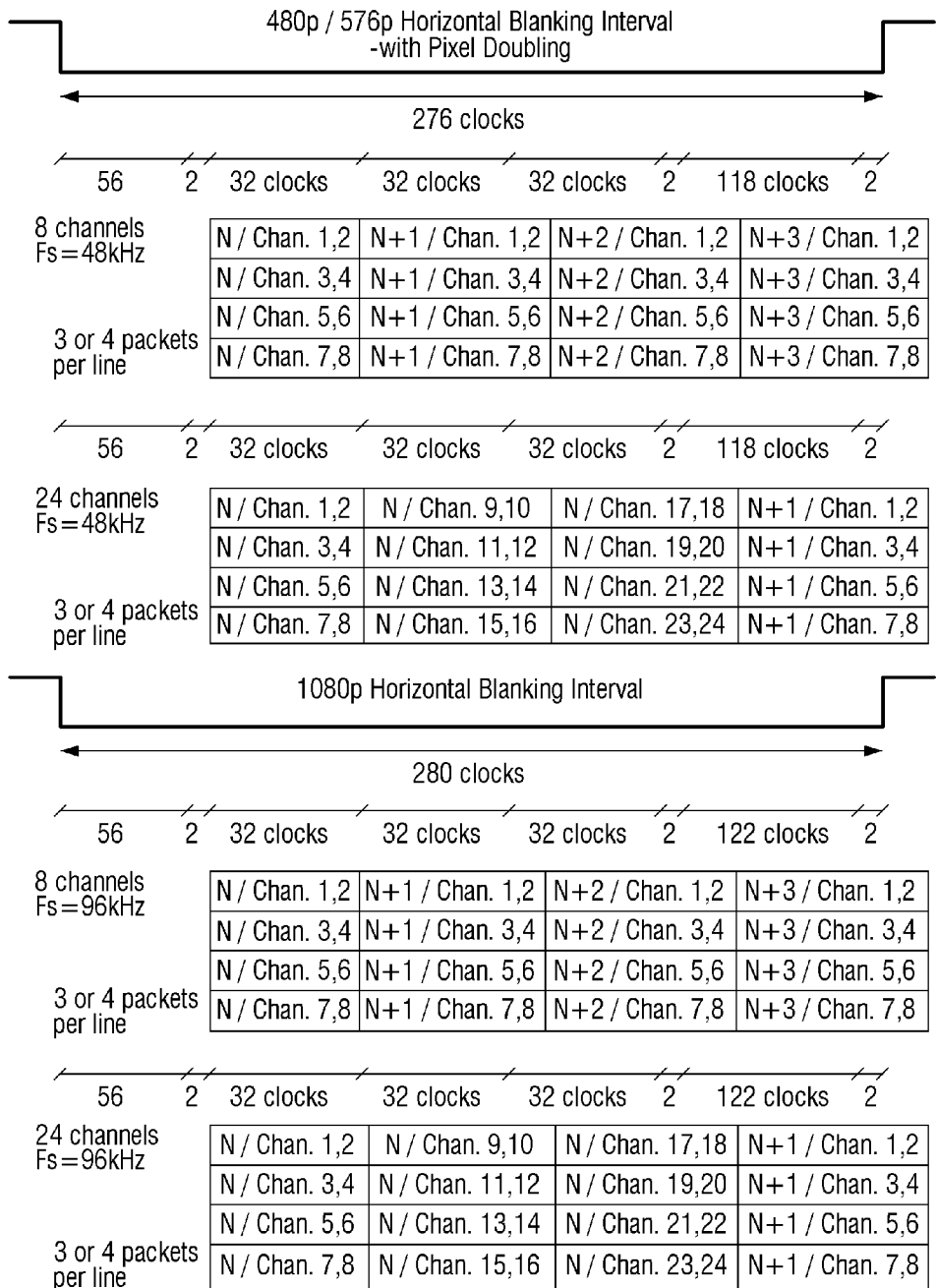

[Fig. 2]

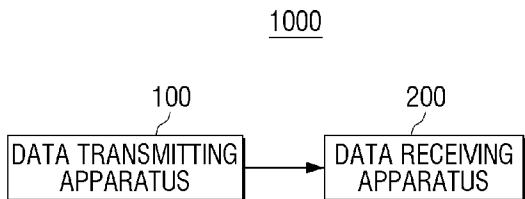

[Fig. 3]

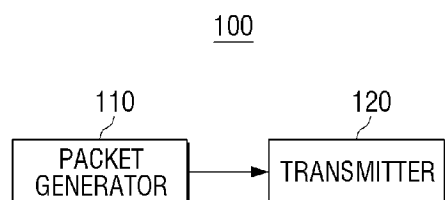





[Fig. 7]

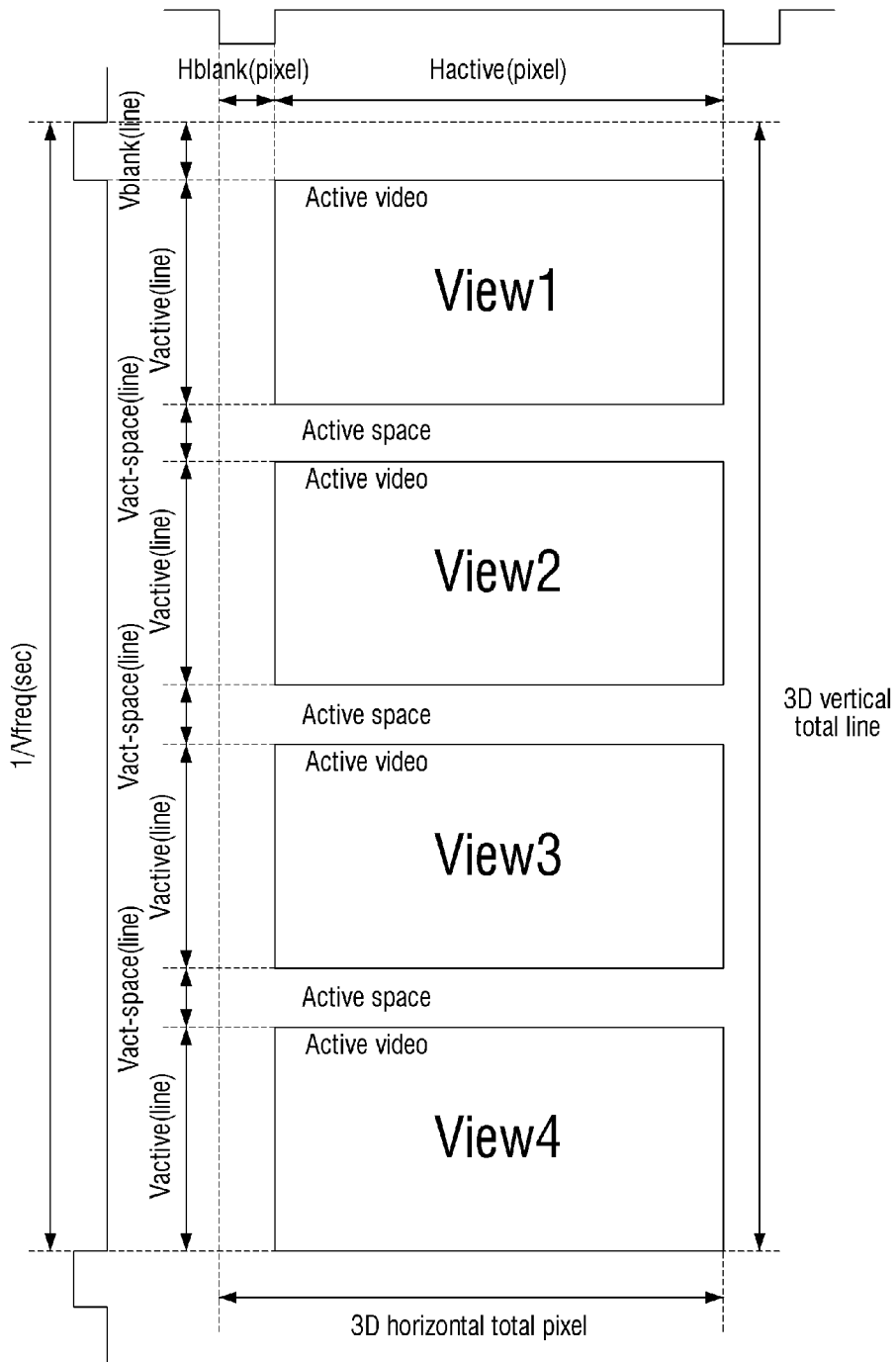

[Fig. 8]

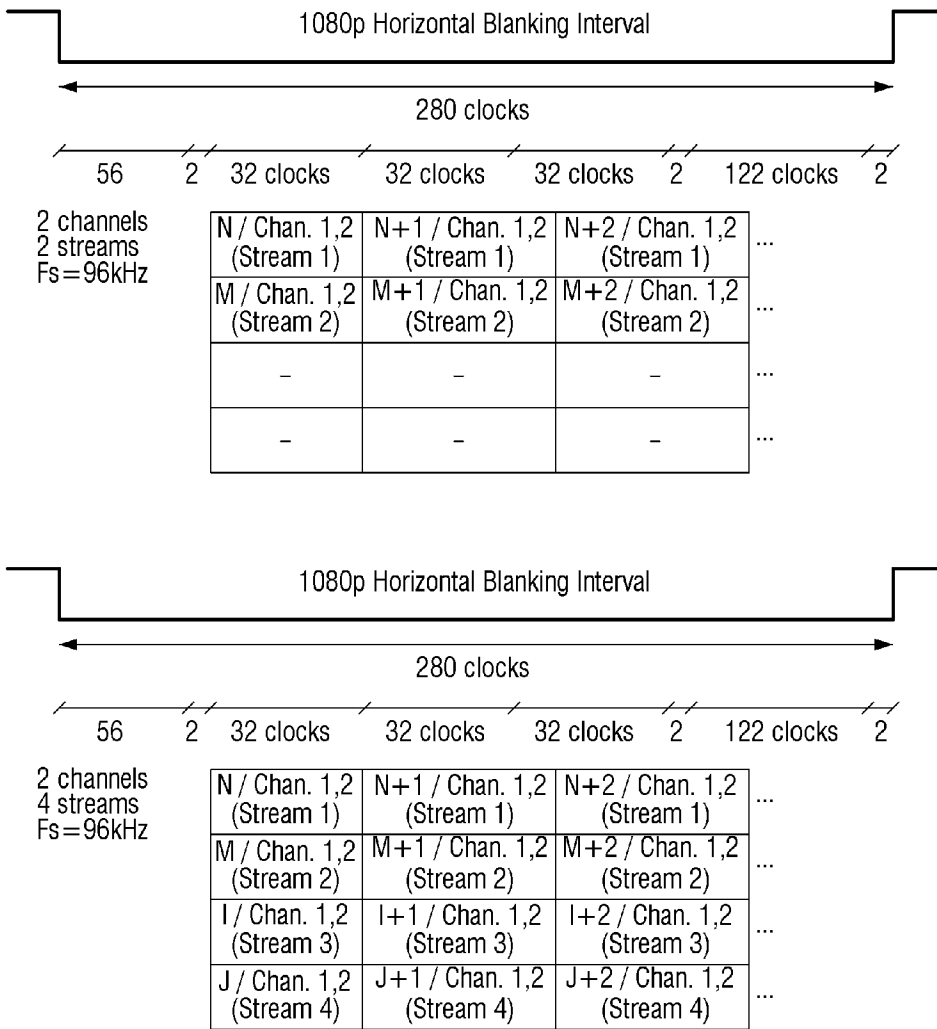

[Fig. 9]

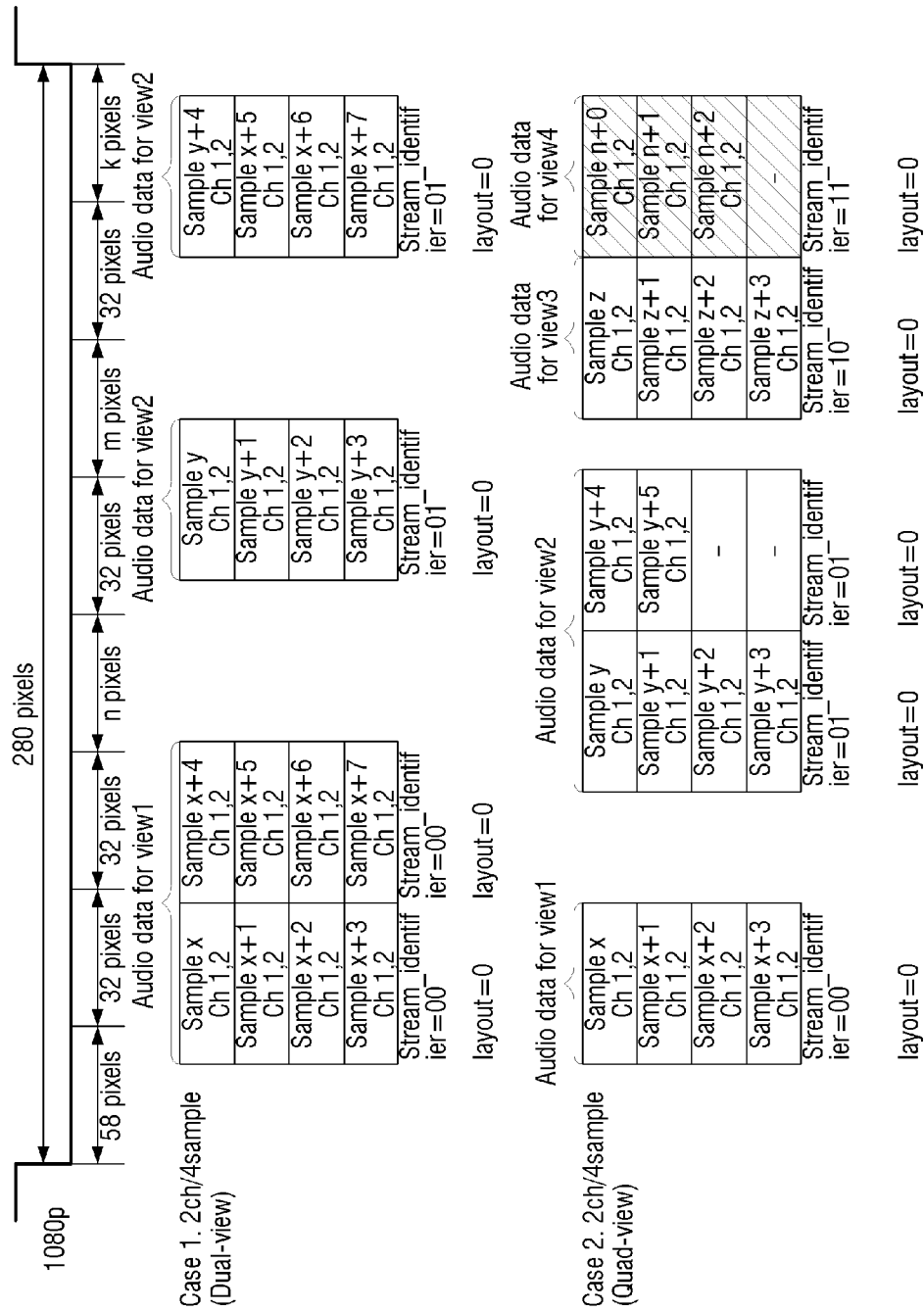

[Fig. 10]

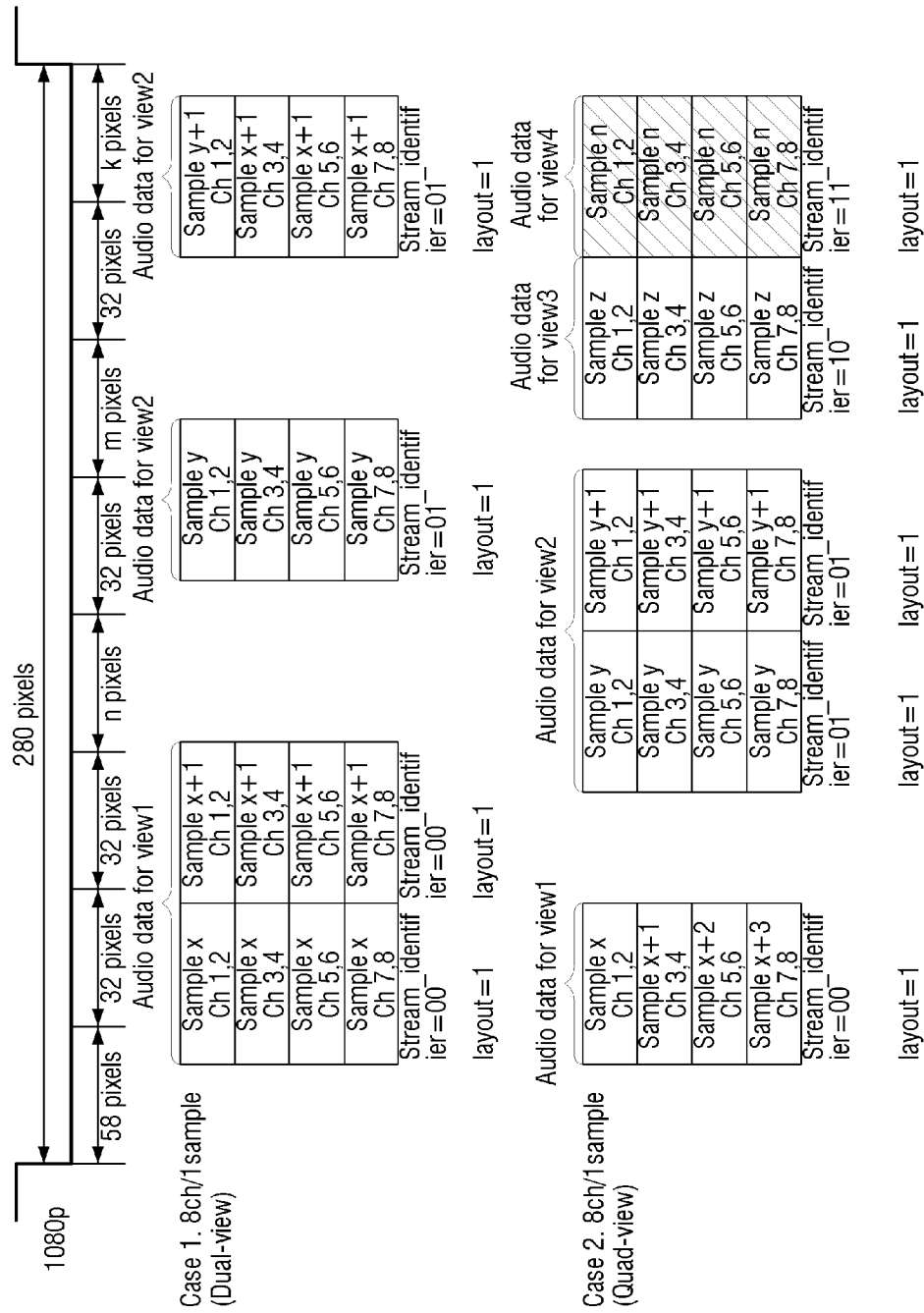

[Fig. 11]

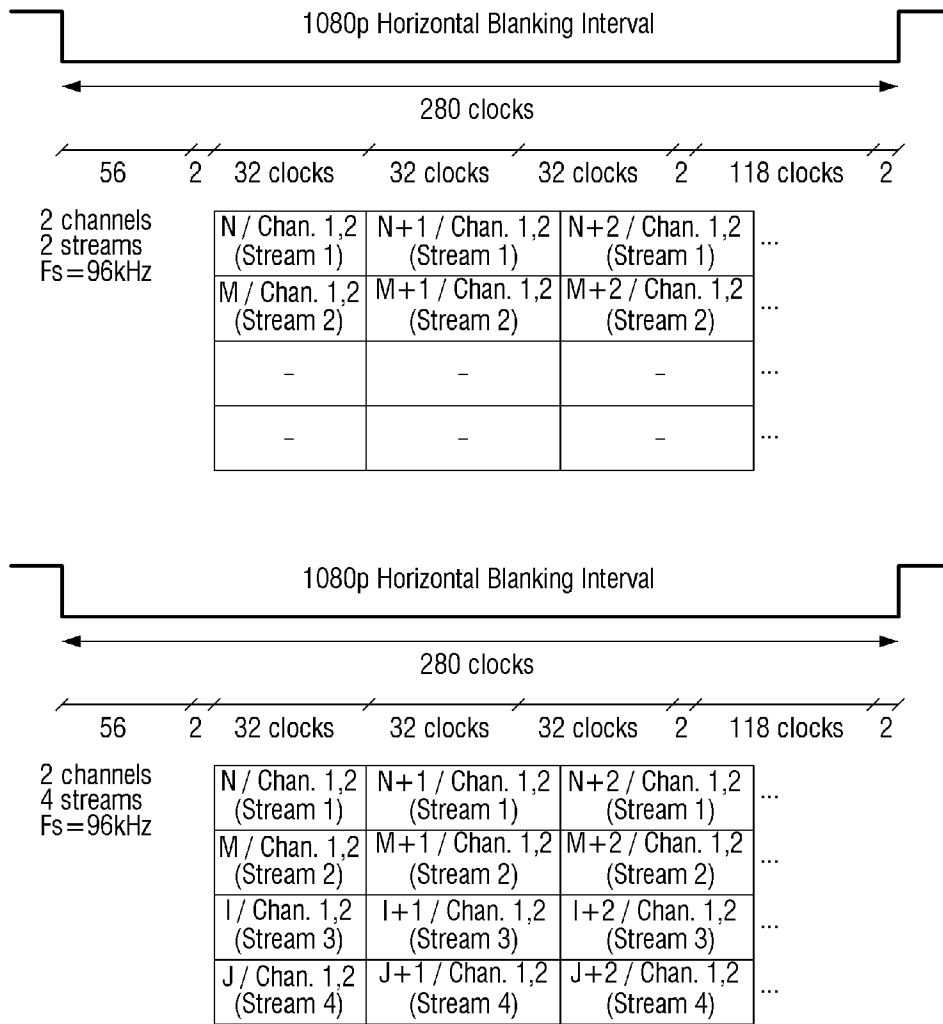

[Fig. 12]

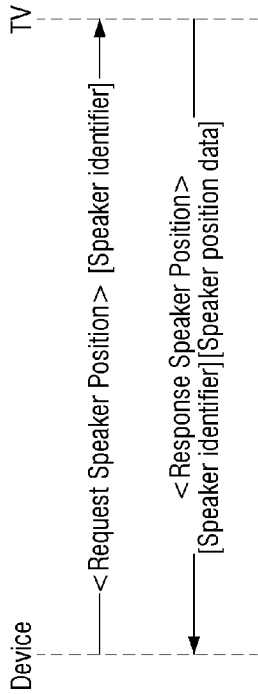

CEC Figure 38 Typical operation to get the position of a speaker

CEC Table 29 Operand Descriptions

Name	Range Description	Length	Purpose
[Speaker position data]	"x_offset"	1 Byte	Used by a source to get the gap away from the default X of a speaker
	"y_offset"	1 Byte	Used by a source to get the gap away from the default Y of a speaker
	"z_offset"	1 Byte	Used by a source to get the gap away from the default Z of a speaker
	"Angle_offset"	2 Bytes	Used by a source to get the gap away from the default angle of a speaker
[Speaker identifier]	"front left"	0x00	
	"front right"	0x01	Specifies the type of speaker placement
		0x01	
	"LFE2"	0x1F	

[Fig. 13]

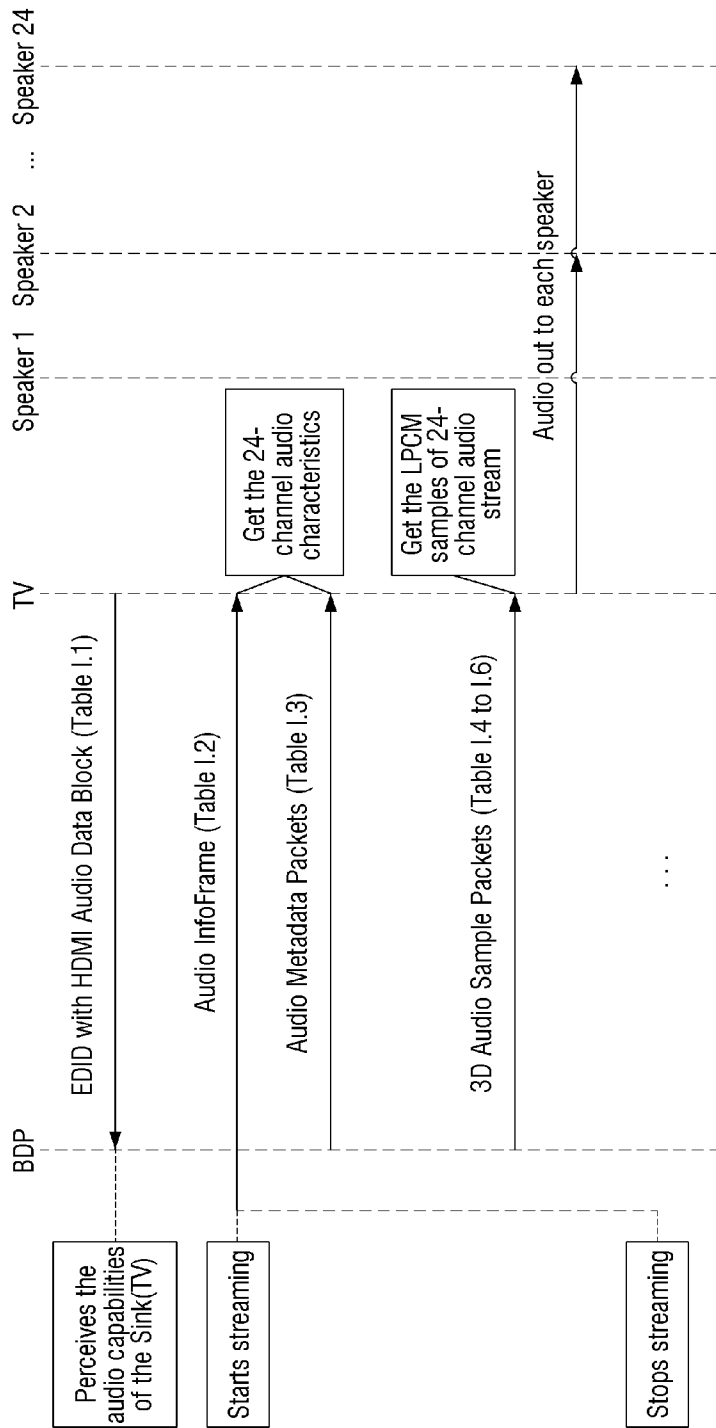

[Fig. 14]

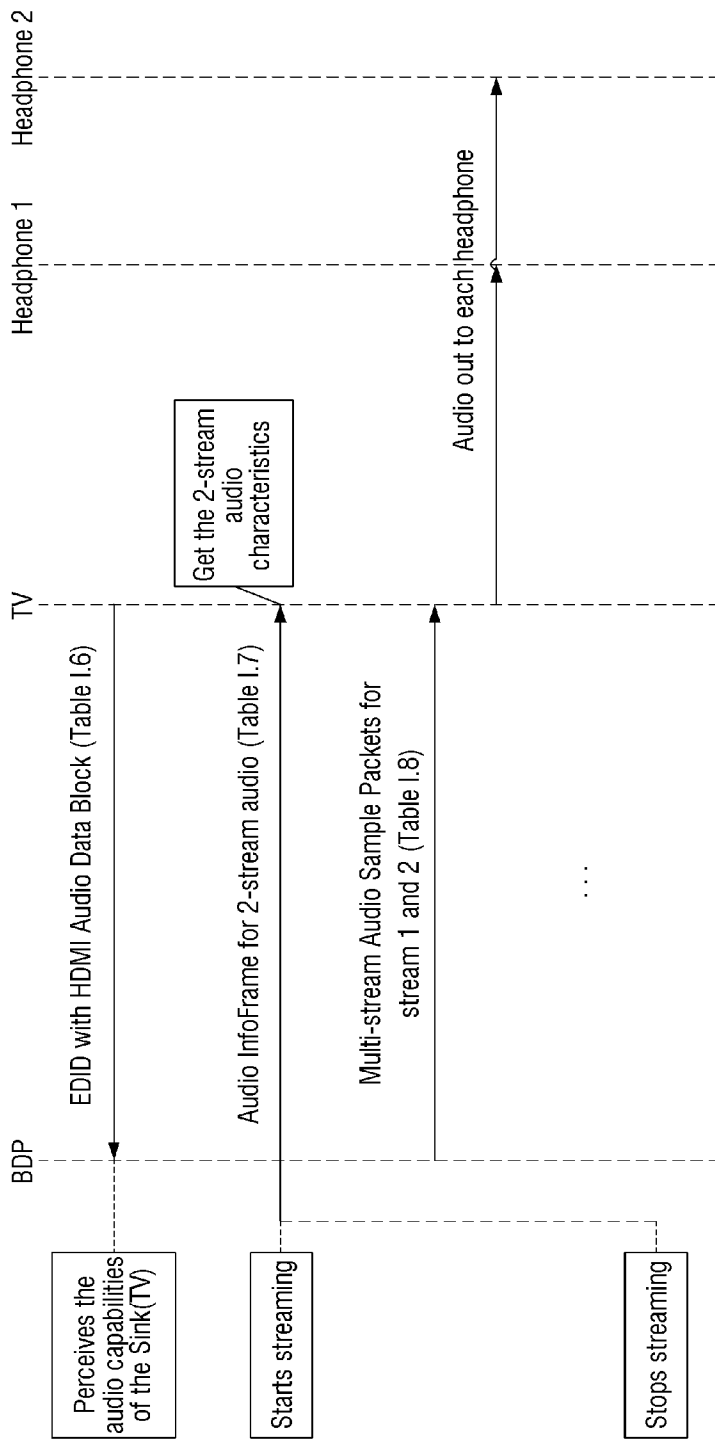

[Fig. 15]

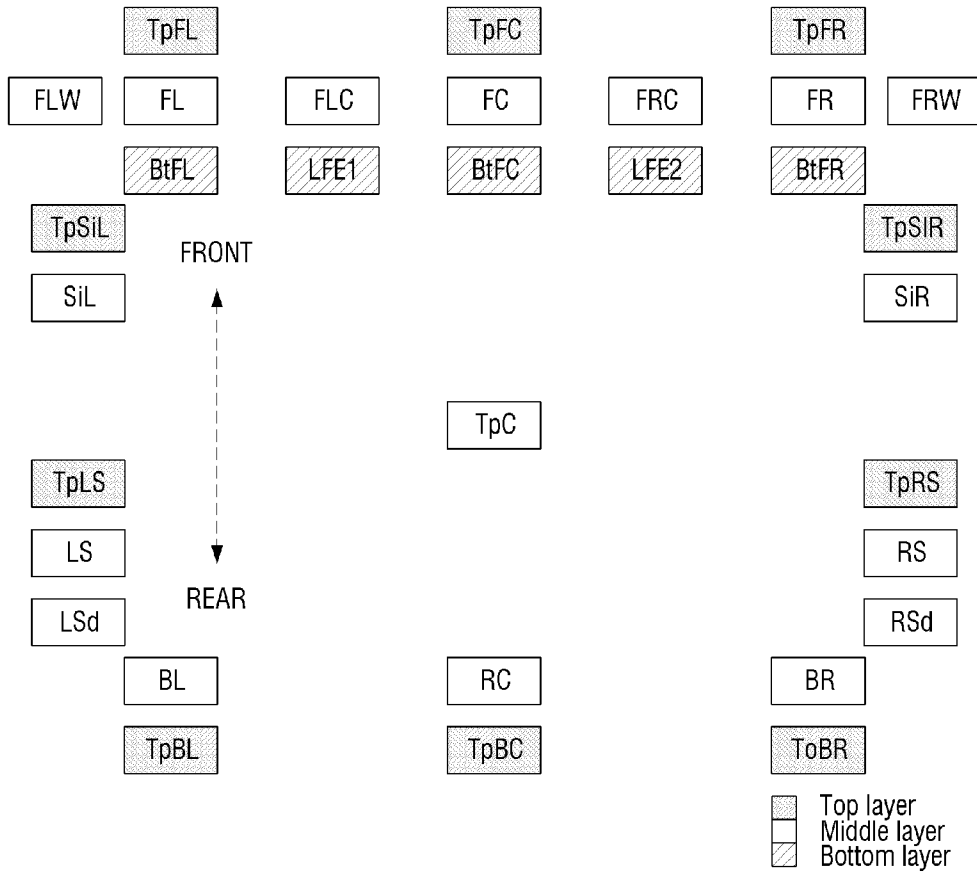

[Fig. 16]

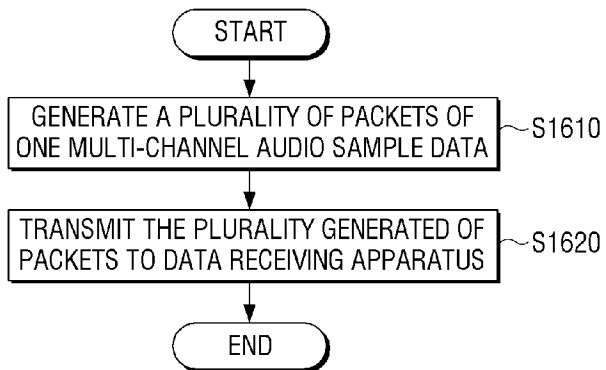

[Fig. 17]

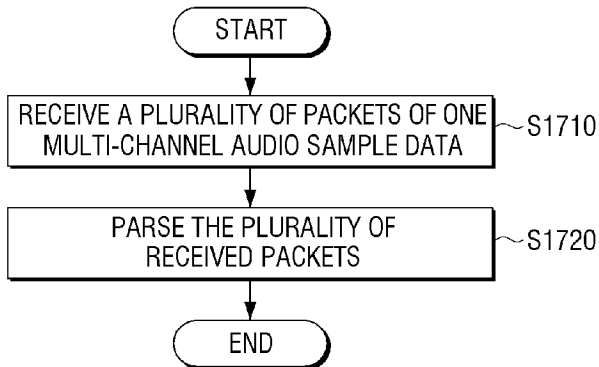

[Fig. 18]

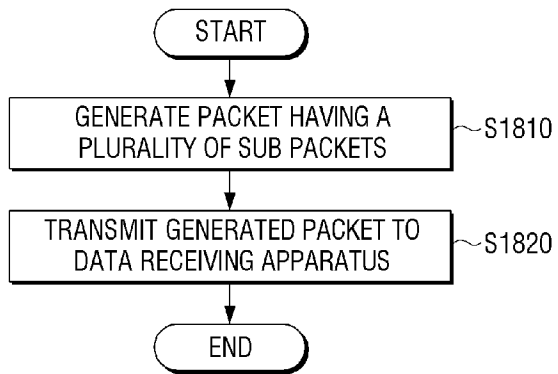

[Fig. 19]

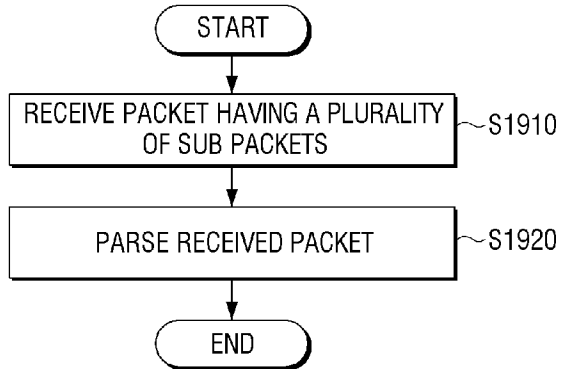

## INTERNATIONAL SEARCH REPORT

International application No.  
**PCT/KR2013/001128****A. CLASSIFICATION OF SUBJECT MATTER****H04S 3/00(2006.01)i, H04R 5/02(2006.01)i, H04N 21/439(2011.01)i**

According to International Patent Classification (IPC) or to both national classification and IPC

**B. FIELDS SEARCHED**

Minimum documentation searched (classification system followed by classification symbols)

H04S 3/00, H04R 5/00, H04N 21/00

Documentation searched other than minimum documentation to the extent that such documents are included in the fields searched

Korean utility models and applications for utility models

Japanese utility models and applications for utility models

Electronic data base consulted during the international search (name of data base and, where practicable, search terms used)

eKOMPASS(KIPO internal) &amp; keywords: audio data, generate, sub, packet, transmit and similar terms.

**C. DOCUMENTS CONSIDERED TO BE RELEVANT**

Category*	Citation of document, with indication, where appropriate, of the relevant passages	Relevant to claim No.
X	US 2010-0215044 A1 (YONG JU LEE et al.) 26 August 2010 See paragraphs 15, 45, 55-79; claims 14, 19; and figures 1, 4.	1-2,4-7,9-13,15
A		3,8,14
A	US 2011-0194701 A1 (WUZHOU ZHAN et al.) 11 August 2011 See paragraphs 138-145; and figure 10.	1-15
A	US 2011-0153043 A1 (PASI OJALA) 23 June 2011 See paragraphs 74-81; and figure 7.	1-15
A	US 2011-0234760 A1 (JEONG HYU YANG et al.) 29 September 2011 See paragraphs 56-60; and figure 6.	1-15
A	KR 10-1099345 B1 (LG ELECTRONICS INC.) 20 December 2011 See paragraphs 106-108; and figure 11.	1-15

 Further documents are listed in the continuation of Box C. See patent family annex.

\* Special categories of cited documents:

"A" document defining the general state of the art which is not considered to be of particular relevance

"E" earlier application or patent but published on or after the international filing date

"L" document which may throw doubts on priority claim(s) or which is cited to establish the publication date of citation or other special reason (as specified)

"O" document referring to an oral disclosure, use, exhibition or other means

"P" document published prior to the international filing date but later than the priority date claimed

"T" later document published after the international filing date or priority date and not in conflict with the application but cited to understand the principle or theory underlying the invention

"X" document of particular relevance; the claimed invention cannot be considered novel or cannot be considered to involve an inventive step when the document is taken alone

"Y" document of particular relevance; the claimed invention cannot be considered to involve an inventive step when the document is combined with one or more other such documents, such combination being obvious to a person skilled in the art

"&amp;" document member of the same patent family

Date of the actual completion of the international search

30 May 2013 (30.05.2013)

Date of mailing of the international search report

**31 May 2013 (31.05.2013)**

Name and mailing address of the ISA/KR

Korean Intellectual Property Office  
189 Cheongsu-ro, Seo-gu, Daejeon Metropolitan City,  
302-701, Republic of Korea

Facsimile No. 82-42-472-7140

Authorized officer

BYUN, Sung Cheal

Telephone No. 82-42-481-8262



**INTERNATIONAL SEARCH REPORT**

Information on patent family members

International application No.

**PCT/KR2013/001128**

Patent document cited in search report	Publication date	Patent family member(s)	Publication date
US 2010-0215044 A1	26.08.2010	EP 2210254 A1	28.07.2010
		EP 2210254 A4	17.08.2011
		KR 10-0942142 B1	16.02.2010
		KR 10-2009-0037278 A	15.04.2009
		US 2013-0077631 A1	28.03.2013
		US 8340096 B2	25.12.2012
		WO 2009-048221 A1	16.04.2009
US 2011-0194701 A1	11.08.2011	EP 2337328 A1	22.06.2011
		WO 2010-045869 A1	29.04.2010
US 2011-0153043 A1	23.06.2011	EP 2517484 A1	31.10.2012
		US 8380333 B2	19.02.2013
		WO 2011-077005 A1	30.06.2011
US 2011-0234760 A1	29.09.2011	EP 2357823 A1	17.08.2011
		KR 10-2011-0106289 A	28.09.2011
		WO 2010-064774 A1	10.06.2010
KR 10-1099345 B1	26.12.2011	CA 2796859 A1	07.06.2012
		US 2012-0140753 A1	07.06.2012
		US 2012-0218981 A1	30.08.2012
		WO 2012-074251 A1	07.06.2012