

1

2

3

4a 4d

5a

5b

5c 5b

*

*

1 : 2 :

3 : 4 :

4a : 4b :

4c : 5 :

6 : 6a :

,

.

,

1

/

,

/

,

,

,

,

,

,

,

,

,

,

,

,

,

,

,

,

,

,

,

,

,

,

,

,

,

,

,

,

,

,

,

,

,

,

,

,

,

,

,

,

,

,

,

,

,

,

,

,

가

가

가

가

가

가 0.4mm , 가 가 1mm , 0.2

1 / (4) (4a) , (4a) (6) (6a)
 (4b) , (4a) (4c)

3 (S40), (S50), (S60), (S10), (S20), (S30),
 (S70) (S10) , (, SCM415 SCM445) 가

가 (S20) , , 1 () (4a)
 (4b)

(S30) , (S20) 가
 4c (7c) 가
 (S40) 가 (7c) 가

(S40) , , 1 () (4c)
) 가 (4d)

가 1mm , 0.2 0.4 mm 가 , 가

(SCM) , 가 , 가

가 , 가 , 가

가 (S20), (S30), (S40)
 , 가

(40) 가 가 . 5a 5a 5c (7d)
 (t₁) (t₁) (t₂)
 (t₁)가 1mm , 0.4mm (t₂)
 5b 5c (7c)
 (t₃) (t₃) (t₄) (7e)가
 1mm (7c) (t₄) (7e) (t₅) 2mm (t₃)가 2.4mm
 (7e)

(S50) , (4d)

(S60) ,

(S70) ,

가 , 가
 가 , 가
 가 , 가
 가 , 가

(57)

1.

가 ;
 ;
 ;
 가 ;
 가 ;
 ;
 ;

2.

1 , 가

3.

1 , 0.2 , 0.4mm 가 가 1mm

4.

1 , , ,

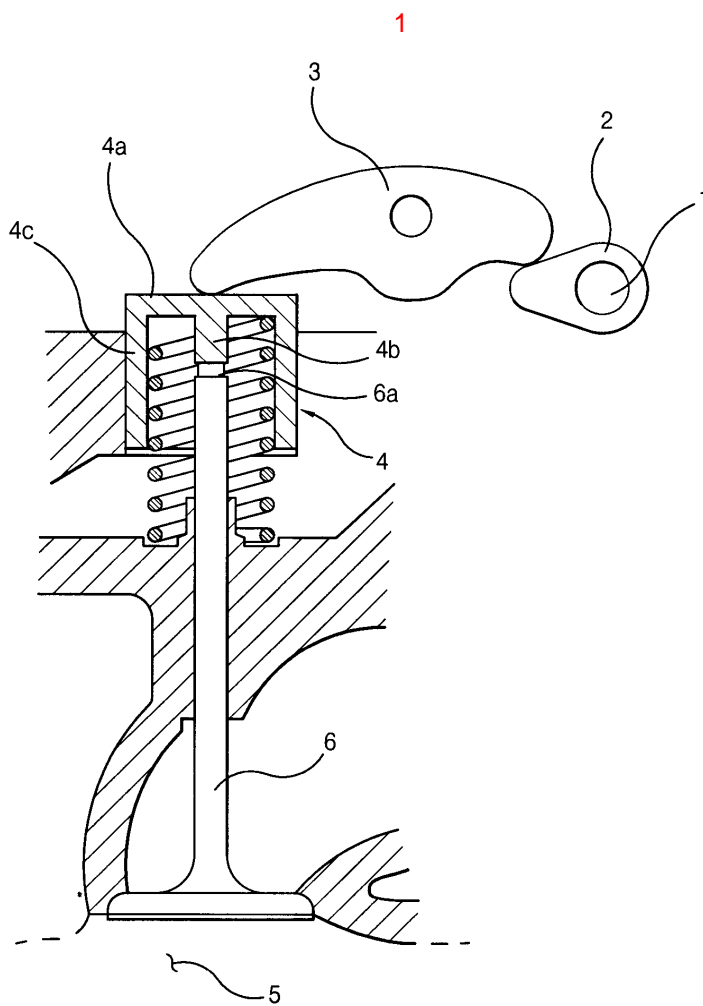

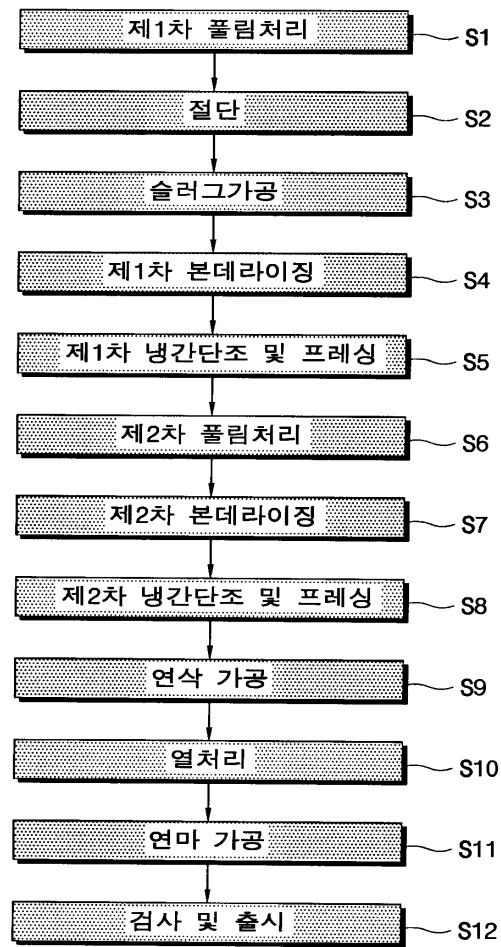

3

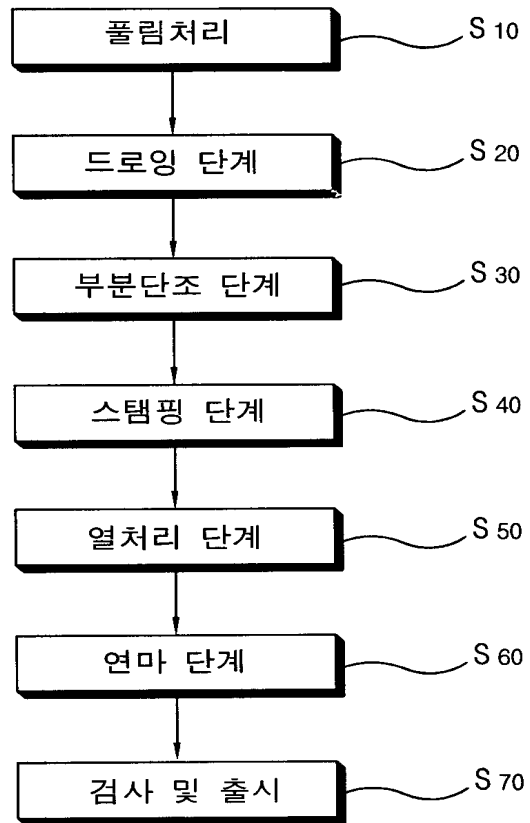

4a

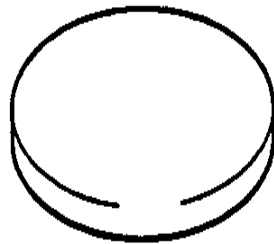

4b

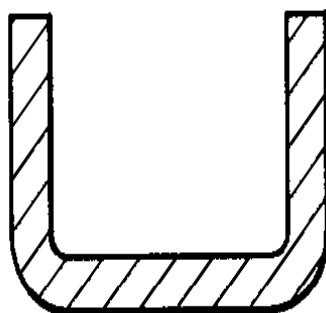

4c

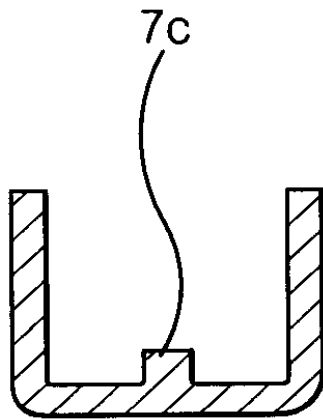

4d

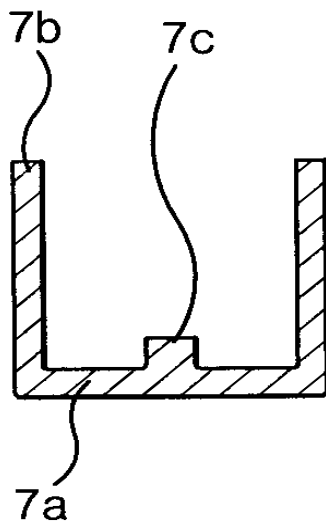

5a

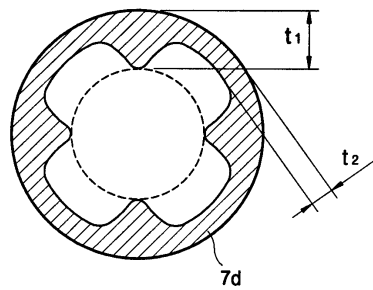

5b

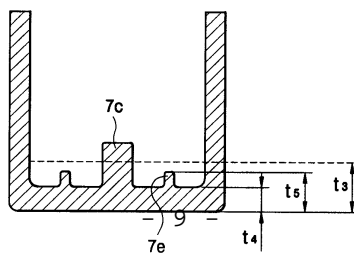

5c

