



- (51) International Patent Classification:
B64D 11/00 (2006.01) *B64D 11/04* (2006.01)
- (21) International Application Number:
PCT/EP2016/062485
- (22) International Filing Date:
2 June 2016 (02.06.2016)
- (25) Filing Language: English
- (26) Publication Language: English
- (30) Priority Data:
10 2015 210 268.8 3 June 2015 (03.06.2015) DE
10 2015 210 269.6 3 June 2015 (03.06.2015) DE
10 2015 210 271.8 3 June 2015 (03.06.2015) DE
- (71) Applicant: AIRBUS OPERATIONS GMBH [DE/DE];
Kreetslag 10, 21129 Hamburg (DE).
- (72) Inventor: TRUEMPER, Torsten; c/o AIRBUS OPERATIONS GMBH, Kreetslag 10, 21129 Hamburg (DE).
- (74) Agent: SCHICKER, Silvia; WUESTHOFF & WUESTHOFF Patentanwälte PartG mbB, Schweigerstrasse 2, 81541 München (DE).

- (81) Designated States (unless otherwise indicated, for every kind of national protection available): AE, AG, AL, AM, AO, AT, AU, AZ, BA, BB, BG, BH, BN, BR, BW, BY, BZ, CA, CH, CL, CN, CO, CR, CU, CZ, DE, DK, DM, DO, DZ, EC, EE, EG, ES, FI, GB, GD, GE, GH, GM, GT, HN, HR, HU, ID, IL, IN, IR, IS, JP, KE, KG, KN, KP, KR, KZ, LA, LC, LK, LR, LS, LU, LY, MA, MD, ME, MG, MK, MN, MW, MX, MY, MZ, NA, NG, NI, NO, NZ, OM, PA, PE, PG, PH, PL, PT, QA, RO, RS, RU, RW, SA, SC, SD, SE, SG, SK, SL, SM, ST, SV, SY, TH, TJ, TM, TN, TR, TT, TZ, UA, UG, US, UZ, VC, VN, ZA, ZM, ZW.
- (84) Designated States (unless otherwise indicated, for every kind of regional protection available): ARIPO (BW, GH, GM, KE, LR, LS, MW, MZ, NA, RW, SD, SL, ST, SZ, TZ, UG, ZM, ZW), Eurasian (AM, AZ, BY, KG, KZ, RU, TJ, TM), European (AL, AT, BE, BG, CH, CY, CZ, DE, DK, EE, ES, FI, FR, GB, GR, HR, HU, IE, IS, IT, LT, LU, LV, MC, MK, MT, NL, NO, PL, PT, RO, RS, SE, SI, SK, SM, TR), OAPI (BF, BJ, CF, CG, CI, CM, GA, GN, GQ, GW, KM, ML, MR, NE, SN, TD, TG).

Published:

— with international search report (Art. 21(3))

(54) Title: TROLLEY COMPARTMENT AND ON-BOARD KITCHEN

FIG 3

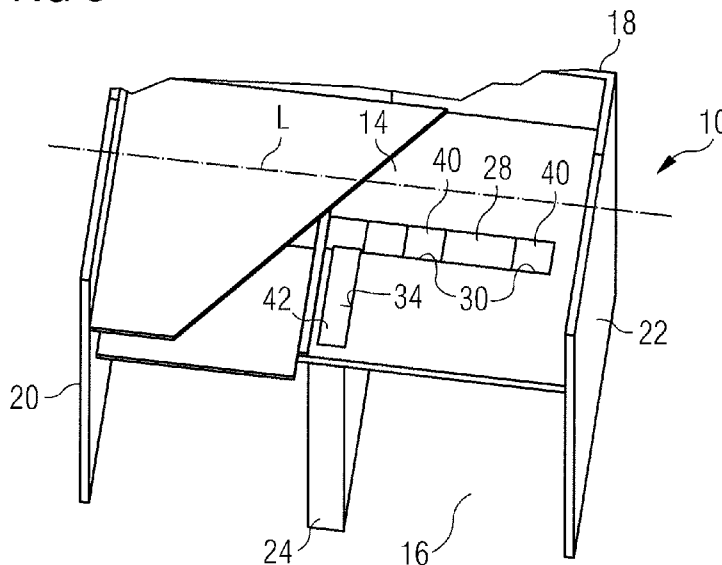

(57) Abstract: A trolley compartment (10) for an on-board kitchen (100) intended for installation in a means of transport comprises a frontal access aperture (16) as well as a rear wall (18) that lies opposite said access aperture (16). A worktop (14) forms an upper boundary of the trolley compartment (10). A first cooling fluid duct (28) which is connectable to an interior space of the trolley compartment (10) via at least one first cooling fluid aperture (30) is integrated into or arranged adjacent to the worktop (14). At least one first removable cooling fluid aperture cover (40) is selectively mountable in the first cooling fluid duct (28) over the first cooling fluid aperture (30) in order to separate said first cooling fluid duct (28) from the interior space of the trolley compartment (10), or demountable from the first cooling fluid duct (28) in order to connect said first cooling fluid duct (28) to the interior space of the trolley compartment (10) via the first cooling fluid aperture (30).

Trolley compartment and on-board kitchen

5 The invention relates to a trolley compartment for an on-board kitchen intended for installation in a means of transport, in particular an aircraft. The invention also relates to an on-board kitchen equipped with a trolley compartment of this kind.

10 Modern commercial aircraft are usually equipped with on-board kitchens, so-called "galleys", which are known, for example, from DE 10 2006 023 047 B4 and US 7,780,114 B2. As a rule, the galleys are installed in the door entry regions of the aircraft cabin and have a corpus with a base structure bounded by a worktop as well as upper compartments which are arranged above said worktop. Kitchen appliances such as, for example, coffee machines, kettles, cookers, etc., as well as drinks and food are usually accommodated in the upper compartments of the galley. Arranged
15 in the base structure of the galley, on the other hand, is a trolley compartment for receiving movable trolleys which are loaded with items, such as drinks and food for example, which are intended to be distributed to the passengers on board the aircraft.

20 On-board kitchens for aircraft may be equipped, as required, with cooled or non-cooled trolley compartments, the design of a galley provided with a cooled trolley compartment differing considerably from the design of a galley with a non-cooled trolley compartment. For example, a galley with a cooled trolley compartment is usually provided with lines for feeding cooling air into the cooled trolley compartment or discharging waste air from said cooled trolley compartment which are laid in the
25 region of a rear wall of the galley corpus, which lines can be dispensed with in the case of a galley with a non-cooled trolley compartment. Moreover, a cooling device, which may be constructed, for example, in the form of an independent air-chiller or connected to a central cooling system of the aircraft, may be installed in a galley with
30 a cooled trolley compartment. On-board kitchens for aircraft that have a cooled trolley compartment therefore usually have a larger floor plan and, in particular, a greater depth than on-board kitchens for aircraft that have a non-cooled trolley compartment.

35 When constructing a commercial aircraft, it is therefore necessary, even at a very early point in time, to establish whether the galleys installed in the aircraft are to be equipped with cooled or non-cooled trolley compartments. Later changes to this

functionality requirement result in expensive adaptations of the entire cabin layout. In most cases, subsequent conversion of a galley with a non-cooled trolley compartment to a galley with a cooled trolley compartment is not possible at all.

5 The underlying object of the invention is to indicate a trolley compartment for an on-board kitchen intended for installation in a means of transport, in particular an aircraft, which makes it possible to decide, in a very flexible manner and at any desired point in time, whether the trolley compartment is constructed as a cooled or a non-cooled trolley compartment. The underlying object of the invention is also to
10 make available an on-board kitchen which is equipped with a trolley compartment of this kind.

This object is achieved by means of a trolley compartment having the features in Claim 1 and an on-board kitchen having the features in Claim 14.

15 A trolley compartment for an on-board kitchen intended for installation in a means of transport comprises a frontal access aperture as well as a rear wall that lies opposite said access aperture. At least one movable trolley, which may be loaded, for example, with drinks, food or other items which are intended to be distributed to
20 passengers in the means of transport, can be pushed into, or moved out of, the trolley compartment through the frontal access aperture. The trolley compartment may also have a door for occluding the access aperture and, if desired, may be sealed off from the surrounding atmosphere by means of a sealing system which is described in DE 10 2010 031 909 A1 or WO 2012/025200 A1.

25 A worktop forms an upper boundary of the trolley compartment. When an on-board kitchen equipped with said trolley compartment is installed in a means of transport, an upper side of the worktop may be used as a working surface. On the other hand, an interior space of the trolley compartment which is intended for receiving at least
30 one movable trolley is bounded in the upward direction by an underside of the worktop. A first cooling fluid duct which is connectable to the interior space of the trolley compartment via at least one first cooling fluid aperture is integrated into the worktop or arranged adjacent to the worktop. In case the first cooling fluid duct is arranged adjacent to the worktop, the first cooling fluid duct may be arranged either
35 below a lower surface of the worktop which faces the interior space of the trolley compartment or above an upper surface of the worktop which faces away from the interior space of the trolley compartment. A first cooling fluid duct arranged above an

upper surface of the worktop may comprise a first portion extending substantially parallel to the upper surface of the worktop and at least one second portion extending substantially perpendicular to the upper surface of the worktop through the worktop. The at least one second portion of the first cooling fluid duct may
5 connect the first portion of the first cooling fluid duct to the at least one first cooling fluid aperture.

Said first cooling fluid duct may be designed either as a cooling fluid feed duct section for feeding cooling fluid into the interior space of the trolley compartment, or
10 as a cooling fluid discharge duct section for discharging cooling fluid, which has been warmed up on flowing through the trolley compartment, from the interior space of said trolley compartment. The cooling fluid which is conducted through the interior space of the trolley compartment is preferably air. Depending upon the size of the trolley compartment, the first cooling fluid duct may be capable of being connected
15 to the interior space of said trolley compartment via a number of first cooling fluid apertures, in which case said first cooling fluid apertures may be arranged in a manner distributed along a longitudinal axis of the trolley compartment that extends parallel to the frontal access aperture and the rear wall of said trolley compartment.

The trolley compartment further comprises at least one removable cooling fluid aperture cover which is selectively mountable in the first cooling fluid duct over the first cooling fluid aperture in order to separate said first cooling fluid duct from the interior space of the trolley compartment, or demountable from the first cooling fluid duct in order to connect said first cooling fluid duct to the interior space of the trolley
20 compartment via the first cooling fluid aperture. If a number of first cooling fluid apertures are provided in the first cooling fluid duct, there is preferably a corresponding number of first removable cooling fluid aperture covers which permit, selectively, sealing-off or unblocking of the first cooling fluid apertures. The first removable cooling fluid aperture cover may be constructed, for example, in the form
25 of a plate made of plastic, metal or the like.

In case of an integration of the first cooling fluid duct into the worktop of the trolley compartment or in case of an arrangement of the first cooling fluid duct above the worktop, no additional installation space for said first cooling fluid duct is required in
35 said trolley compartment. In any case, i.e. also in case of an arrangement of the first cooling fluid duct below the worktop, it is possible to dispense with arranging the first cooling fluid duct in the region of the rear wall of the trolley compartment. A cooled

trolley compartment can accordingly be produced which has the same depth, i.e. the same distance between the frontal access aperture and the rear wall, as a non-cooled trolley compartment. When planning the layout of a passenger cabin of the means of transport, it is therefore not necessary to decide, even at a very early point in time, whether an on-board kitchen with a cooled trolley compartment or an on-board kitchen with a non-cooled trolley compartment is to be installed in the passenger cabin. On the contrary, it is possible, when planning the layout of the passenger cabin, to start out from the installation of an on-board kitchen with a trolley compartment having standard dimensions and to decide, only at a later point in time, whether said trolley compartment is to be designed as a cooled trolley compartment or as a non-cooled trolley compartment.

If the decision has been made to construct the trolley compartment as a non-cooled trolley compartment, the first cooling fluid aperture may be occluded by means of the first removable cooling fluid aperture cover, and the first cooling fluid duct may thereby be separated from the interior space of said trolley compartment. The first removable cooling fluid aperture cover then prevents dirt from penetrating into the first cooling fluid duct. If, on the other hand, the trolley compartment is to be designed as a cooled trolley compartment, the installation of the first removable cooling fluid aperture cover in the first cooling fluid duct is dispensed with, or else said first removable cooling fluid aperture cover is demounted from said first cooling fluid duct in order to unblock the first cooling fluid aperture and thus connect the first cooling fluid duct to the interior space of the trolley compartment. Accordingly, said trolley compartment can be flexibly configured, in a very simple manner, as a cooled trolley compartment or as a non-cooled trolley compartment, as required. Moreover, a subsequent conversion of the trolley compartment from a cooled trolley compartment to a non-cooled trolley compartment or *vice versa* is very easily possible.

In one preferred embodiment, the trolley compartment further comprises a first removable fluid-permeable, grille-type cooling fluid aperture cover which is selectively mountable in the first cooling fluid duct over the first cooling fluid aperture, or demountable from said first cooling fluid duct. The first fluid-permeable, grille-type cooling fluid aperture cover permits the passage of cooling fluid, but holds back dirt. If the trolley compartment is to be constructed as a cooled trolley compartment, and the first removable cooling fluid aperture cover is accordingly dispensed with, the first removable fluid-permeable, grille-type cooling fluid aperture

cover is therefore preferably fitted over the first cooling fluid aperture. If a number of first cooling fluid apertures are provided in the first cooling fluid duct, there is preferably a corresponding number of first removable grille-type cooling fluid aperture covers, which permit, selectively, fluid-permeable covering, or else complete unblocking, of said first cooling fluid apertures.

The trolley compartment may also comprise a second cooling fluid duct. Said second cooling fluid duct may be connectable to the first cooling fluid duct via a connecting aperture provided in said first cooling fluid duct. Depending upon the configuration of the first cooling fluid duct as a cooling fluid feed duct section or as a cooling fluid discharge duct section, the second cooling fluid duct may also be designed as a cooling fluid feed duct section for feeding cooling fluid into the interior space of the trolley compartment, or as a cooling fluid discharge duct section for discharging cooling fluid, which has been warmed up on flowing through the trolley compartment, from the interior space of said trolley compartment. For example, the first and second cooling fluid ducts may jointly form a cooling fluid discharge duct through which cooling fluid which has been warmed up on flowing through the trolley compartment is discharged from the interior space of said trolley compartment and fed to a cooling fluid inlet of a cooling device. As an alternative to this, however, the first and second cooling fluid ducts may also jointly form a cooling fluid feed duct through which cooling fluid which passes out of a cooling fluid outlet of a cooling device is conducted into the interior space of the trolley compartment.

The second cooling fluid duct is preferably integrated into a sidewall or partition of the trolley compartment. Said second cooling fluid duct then requires particularly little additional installation space. As an alternative to this, however, it is also conceivably possible to arrange the second cooling fluid duct adjacently to a sidewall or adjacently to a partition of the trolley compartment. Installation of the second cooling fluid duct in a sidewall or adjacently to a sidewall of said trolley compartment is particularly appropriate if the trolley compartment has fairly small dimensions and is suitable for accommodating only one trolley or a small number of trolleys. On the other hand, installation of the second cooling fluid duct in a partition or adjacently to a partition of the trolley compartment is advantageous if the trolley compartment in question is one which has fairly large dimensions and in which a plurality of trolleys can be accommodated.

The second cooling fluid duct may be formed by a cavity which is present in a partition or a sidewall of the trolley compartment. As an alternative to this, however, said second cooling fluid duct may also be formed by a separately constructed component which optionally may, or may not, be provided in the trolley
5 compartment, that is to say depending upon whether said trolley compartment is to be cooled or not.

A removable connecting aperture cover may be selectively mountable in the first cooling fluid duct over the connecting aperture in order to separate said first cooling
10 fluid duct from the second cooling fluid duct, or demountable from the first cooling fluid duct in order to connect said first cooling fluid duct to the second cooling fluid duct via the connecting aperture. In the case of a non-cooled trolley compartment, the connecting aperture may be occluded by means of the removable connecting
15 aperture cover, and the first cooling fluid duct thereby separated from the second cooling fluid duct. In the case of a cooled trolley compartment, on the other hand, installation of the removable connecting aperture cover in the first cooling fluid duct is dispensed with, or the removable connecting aperture cover is demounted from
20 the first cooling fluid duct in order to unblock the connecting aperture and thus connect said first cooling fluid duct to the second cooling fluid duct of the trolley compartment.

If desired, the trolley compartment may also comprise a removable fluid-permeable, grille-type connecting aperture cover which is selectively mountable in the first
25 cooling fluid duct over the connecting aperture, or demountable from said first cooling fluid duct. In a manner similar to the first fluid-permeable, grille-type cooling fluid aperture cover, the fluid-permeable, grille-type connecting aperture cover also permits the passage of cooling fluid, but holds back dirt particles or the like. If the trolley compartment is to be constructed as a cooled trolley compartment, and the removable connecting aperture cover is accordingly dispensed with, it is therefore
30 possible to fit the removable fluid-permeable, grille-type connecting aperture cover over the connecting aperture.

The trolley compartment preferably further comprises an installation space for a cooling device, which installation space is connected to the second cooling fluid duct.
35 Said cooling device may be designed, for example, in the form of an independent air-chiller. As an alternative to this, however, the cooling device may also be connected to a central cooling system of the means of transport and comprise, for example, a

heat exchanger through which a cooling fluid flows and within which air is cooled to a desired low temperature before being fed into the trolley compartment. The installation space for a cooling device may be arranged adjacently to a sidewall or a partition of the trolley compartment. Preferably, however, the installation space for a cooling device is integrated, in a particularly space-saving manner, into a side wall or a partition of the trolley compartment. Installation of the installation space for a cooling device in a sidewall or adjacently to a sidewall of the trolley compartment is particularly appropriate if said trolley compartment has fairly small dimensions and is suitable for accommodating only one trolley or a small number of trolleys. On the other hand, installation of the installation space for a cooling device in a partition or adjacently to a partition of the trolley compartment is advantageous if the trolley compartment in question is one which has fairly large dimensions and in which a plurality of trolleys can be accommodated.

In one embodiment of the trolley compartment, the installation space for a cooling device may be so arranged that it permits positioning of said cooling device immediately underneath the worktop. The second cooling fluid duct may then be formed by the connecting aperture or an inner peripheral wall of the connecting aperture constructed in the worktop.

The trolley compartment may also comprise a third cooling fluid duct which is connected to the installation space for a cooling device and which is connectable to the interior space of said trolley compartment via a second cooling fluid aperture. The third cooling fluid duct thus produces, if required, i.e. if the trolley compartment is constructed as a cooled trolley compartment, a direct connection between the installation space for a cooling device and the interior space of said trolley compartment. Said third cooling fluid duct may be designed either as a cooling fluid feed duct for feeding cooling fluid into the interior space of the trolley compartment, or as a cooling fluid discharge duct for discharging cooling fluid, which has been warmed up on flowing through the trolley compartment, from the interior space of said trolley compartment.

The third cooling fluid duct may be arranged adjacently to a sidewall or a partition of the trolley compartment. Preferably, however, said third cooling fluid duct is integrated into a side wall or a partition of the trolley compartment. Installation of the third cooling fluid duct in a sidewall or adjacently to a sidewall of the trolley compartment is particularly appropriate if said trolley compartment has fairly small

5 dimensions and is suitable for accommodating only one trolley or a small number of trolleys. On the other hand, installation of the third cooling fluid duct in a partition or adjacently to a partition of the trolley compartment is advantageous if the trolley compartment in question is one which has fairly large dimensions and in which a plurality of trolleys can be accommodated. Particularly if the third cooling fluid duct is installed adjacently to a partition or is integrated into said partition, two second cooling fluid apertures are preferably present, which connect the third cooling fluid duct to two sections of the trolley compartment interior space which are separated from one another by the partition.

10 The third cooling fluid duct may be formed by a cavity which is present in a partition or a sidewall of the trolley compartment. As an alternative to this, however, said third cooling fluid duct may also be formed by a separately constructed component which optionally may, or may not, be provided in the trolley compartment, that is to say depending upon whether said trolley compartment is to be cooled or not.

15 A free space may be defined between a lower edge of the partition and a floor of the trolley compartment. Thus, cooling fluid may circulate between the two sections of the trolley compartment interior space which are separated from one another by the partition.

20 A second removable cooling fluid aperture cover may be selectively mountable in the third cooling fluid duct over the second cooling fluid aperture in order to separate said third cooling fluid duct from the interior space of the trolley compartment, or demountable from the third cooling fluid duct in order to connect said third cooling fluid duct to the interior space of the trolley compartment via the second cooling fluid aperture. In the case of a non-cooled trolley compartment, the second cooling fluid aperture may be occluded by means of the second removable cooling fluid aperture cover, and the third cooling fluid duct thereby separated from the interior space of the trolley compartment. Said second removable cooling fluid aperture cover then prevents the penetration of dirt into the third cooling fluid duct. In the case of a cooled trolley compartment, on the other hand, installation of the second removable cooling fluid aperture cover in the third cooling fluid duct is dispensed with, or the second removable cooling fluid aperture cover is demounted from the third cooling fluid duct in order to unblock the second cooling fluid aperture and thus connect said third cooling fluid duct to the interior space of the trolley compartment. If a number of second cooling fluid apertures are provided in the third cooling fluid duct, there is

preferably a corresponding number of second removable cooling fluid aperture covers which permit, selectively, sealing-off or unblocking of the second cooling fluid apertures.

5 The trolley compartment may also comprise a second removable fluid-permeable, grille-type cooling fluid aperture cover which is selectively mountable in the third cooling fluid duct over the second cooling fluid aperture, or demountable from said third cooling fluid duct. In a manner similar to the first fluid-permeable, grille-type cooling fluid aperture cover, the second fluid-permeable, grille-type cooling fluid
10 aperture cover also permits the passage of cooling fluid, but holds back dirt. If the trolley compartment is to be constructed as a cooled trolley compartment, and the second removable cooling fluid aperture cover is accordingly dispensed with, the second removable fluid-permeable, grille-type cooling fluid aperture cover is therefore preferably fitted over the second cooling fluid aperture. If a number of
15 second cooling fluid apertures are provided in the third cooling fluid duct, there is preferably a corresponding number of second removable grille-type cooling fluid aperture covers which permit, selectively, fluid-permeable covering, or complete unblocking, of said second cooling fluid apertures.

20 The worktop of the trolley compartment may comprise a first layer as well as a second layer which is separated from the first layer by spacers.

The first cooling fluid duct may be integrated into the first layer. A multilayer makeup of this kind for the worktop makes it possible to integrate the first cooling fluid duct
25 into said worktop particularly easily.

A pull-out table may be arranged in a cavity which is formed by the spacers between the first and second layers of the worktop. When the pull-out table is in its pulled-out position, it enlarges the working surface formed by the upper side of the worktop. In its inoperative position, on the other hand, it is integrated into said worktop and
30 requires no additional installation space.

The trolley compartment may be provided with an insulating layer in the region of at least one sidewall and/or its rear wall. If the trolley compartment is constructed as a cooled trolley compartment, said insulating layer prevents too much cooling energy
35 being given off, via the sidewall, the sidewalls and/or the rear wall of the trolley compartment, to the area surrounding said trolley compartment.

An on-board kitchen which is intended for installation in a means of transport comprises a trolley compartment which has been described above.

5 A trolley compartment which has been described above and/or an on-board kitchen which has been described above is/are particularly advantageously suitable for use in an aircraft.

A preferred embodiment of the invention will now be explained in greater detail with the aid of the appended diagrammatic drawings, in which:

10 Figure 1 shows a diagrammatic general representation of a first embodiment of an on-board kitchen;

15 Figure 2 shows a trolley compartment belonging to the on-board kitchen according to Figure 1, in a three-dimensional oblique view;

Figure 3 shows the trolley compartment according to Figure 2, in a partly cutaway three-dimensional top view;

20 Figure 4 shows an exploded representation of a worktop of the trolley compartment according to Figure 2;

Figure 5 shows a detail of the worktop according to Figure 4, in a cross-sectional view;

25 Figure 6 shows a detail of an alternative worktop, in a cross-sectional view;

Figure 7 shows a detail of a further alternative worktop, in a cross-sectional view; and

30 Figure 8 shows a diagrammatic general representation of a second embodiment of an on-board kitchen.

35 Figure 1 shows a first embodiment of an on-board kitchen 100 which is particularly suitable for installation in a passenger cabin of a commercial aircraft. Said on-board kitchen 100 comprises a corpus 102 with a base structure 104 as well as upper compartments 106 arranged above said base structure 104. Kitchen appliances such

as, for example, coffee machines, kettles, cookers, etc., as well as drinks and food are accommodated in the upper compartments 106. Arranged in the base structure 104 of the on-board kitchen 100, on the other hand, is a trolley compartment 10 for receiving movable trolleys 12 which are loaded with items, such as drinks and food for example, which are intended to be distributed to the passengers in the passenger cabin of the commercial aircraft. The trolley compartment 10 is bounded in the upward direction by a worktop 14, the upper side of which forms a working surface for work to be carried out in the on-board kitchen 100.

As can be seen in Figures 2 and 3, the trolley compartment 10 comprises a frontal access aperture 16 as well as a rear wall 18 that lies opposite said access aperture 16. The access aperture 16 can be occluded by means of a door, which is not illustrated in the figures. A first and a second sidewall 20, 22 of the trolley compartment 10 extend parallel to one another and substantially perpendicularly to the rear wall 18. A partition 24 subdivides an interior space of the trolley compartment 10 into a first section, which is bounded by the first sidewall 20 and the partition 24, and a second section which is bounded by said partition 24 and the second sidewall 22. Integrated into the partition 24 is an installation space 26 for a cooling device (not shown in the figures). The cooling device which is to be installed in the installation space 26 may be constructed in the form of an independent air-chiller or be intended for connection to a central cooling system of the aircraft. The trolley compartment 10 is provided with an insulating layer 27 in the region of its sidewalls 20, 22 and its rear wall 18.

As can best be seen in Figures 3 to 5, in the on-board kitchen 100 according to Figure 1, a first cooling fluid duct 28 is integrated into the worktop 14. Said first cooling fluid duct 28 can be connected, via a plurality of first cooling fluid apertures 30, to the interior space of the trolley compartment 10, said first cooling fluid apertures 30 being arranged in a manner distributed along a longitudinal axis L of the trolley compartment 10 that extends parallel to the frontal access aperture 16 and the rear wall 18 of said trolley compartment 10.

Alternatively, it is, however, also conceivable to equip the on-board kitchen 100 of Figure 1 with a first cooling fluid duct 28 which is arranged adjacent to the worktop 14. Specifically, as shown in Figure 6, the first cooling fluid duct 28 may be arranged below a lower surface of the worktop 14 which faces the interior space of the trolley compartment 10. Alternatively, as shown in Figure 7, the first cooling fluid duct 28

may also be arranged above an upper surface of the worktop 14. In the configuration depicted in Figure 7, the first cooling fluid duct 28 comprises a first portion 28a extending substantially parallel to the upper surface of the worktop 14 and a plurality of second portions 28b extending substantially perpendicular to the upper surface of the worktop 14 through the worktop 14. The second portions of the first cooling fluid duct 28 connect the first portion 28a of the first cooling fluid duct 28 to the plurality of first cooling fluid apertures 30.

A second cooling fluid duct 32 is integrated into the partition 24 of the trolley compartment 10 and can be connected, at its first end, to the first cooling fluid duct 28 via a connecting aperture 34 (see Figure 2). At its second end, the second cooling fluid duct 32 is connected to the installation space 26 for a cooling device. Finally, there is integrated into the partition 24 of the trolley compartment 10 a third cooling fluid duct 36 which is connected, at its first end, to the installation space 26 for a cooling device. At its second end, the third cooling fluid duct 36 can be connected to the interior space of the trolley compartment 10 via two second cooling fluid apertures 38, one second cooling fluid aperture 38, in each case, opening into the first section, which is bounded by the first sidewall 20 and the partition 24, and into the second section, which is bounded by the partition 24 and the second sidewall 22, of the interior space of the trolley compartment 10.

The second and/or the third cooling fluid duct 32, 36 may be formed by a cavity which is present in the partition 24 of the trolley compartment 10. As an alternative to this, however, the second and/or the third cooling fluid duct 32, 36 may also be formed by separately constructed components which may, or may not, be incorporated in the cavities present in the partition 24 of the trolley compartment 10, that is to say depending upon whether said trolley compartment 10 is to be cooled or not.

In an alternative embodiment of the trolley compartment 10 which is not illustrated in the figures, the installation space 26 for a cooling device may be so arranged that it permits positioning of said cooling device immediately underneath the worktop 14. The second cooling fluid duct 32 may then be formed by the connecting aperture 34 or an inner peripheral wall of the first connecting aperture 34 constructed in the worktop 14.

As a result of the integration of the first cooling fluid duct 28 into the worktop 14 as well as the integration of the second cooling fluid duct 32, the third cooling fluid duct 36 and the installation space 26 for a cooling device into the partition 24 of the trolley compartment 10, it is possible to dispense with the installation of internal fittings in the region of the rear wall 18 of said trolley compartment 10. The trolley compartment 10 thus has the same depth, i.e. the distance of the access aperture 16 from the rear wall 18 remains the same, irrespective of whether the trolley compartment 10 is to be constructed as a cooled trolley compartment 10 or as a non-cooled trolley compartment 10.

Moreover, the trolley compartment 10 can be easily converted from a cooled trolley compartment 10 to a non-cooled trolley compartment 10, and *vice versa*. For this purpose, the trolley compartment 10 comprises first removable cooling fluid aperture covers 40 which can selectively be mounted in the first cooling fluid duct 28 over the first cooling fluid apertures 30 in order to separate said first cooling fluid duct 28 from the interior space of the trolley compartment 10, or demounted from the first cooling fluid duct 28 in order to connect said first cooling fluid duct 28 to the interior space of the trolley compartment 10 via the first cooling fluid apertures 30. Also provided is a removable connecting aperture cover 42 which can selectively be mounted in the first cooling fluid duct 28 over the connecting aperture 34 in order to separate said first cooling fluid duct 28 from the second cooling fluid duct 32, or demounted from the first cooling fluid duct 28 in order to connect said first cooling fluid duct 28 to the second cooling fluid duct 32 via the connecting aperture 34. Finally, there are two second removable cooling fluid aperture covers 44 which can selectively be mounted in the third cooling fluid duct 36 over the two second cooling fluid apertures 38 in order to separate said third cooling fluid duct 36 from the interior space of the trolley compartment 10, or demounted from the third cooling fluid duct 36 in order to connect said third cooling fluid duct 36 to the interior space of the trolley compartment 10 via the second cooling fluid apertures 38. The first removable cooling fluid aperture covers 40, the connecting aperture cover 42 and the second removable cooling fluid aperture covers 44 are each constructed in the form of plates made of metal, plastic or the like.

If the trolley compartment 10 is to be constructed as a non-cooled trolley compartment 10 or converted from a cooled trolley compartment 10 to a non-cooled trolley compartment 10, the first removable cooling fluid aperture covers 40 are positioned in the first cooling fluid duct 28 over the first cooling fluid apertures 30

and said first cooling fluid duct 28 is thereby occluded in relation to the interior space of the trolley compartment 10. In a similar manner, the connecting aperture cover 42 is arranged in the first cooling fluid duct 28 over the connecting aperture 34, so that said first cooling fluid duct 28 is also occluded in relation to the second cooling fluid duct 32. In this way, the penetration of dirt into the first cooling fluid duct 28 is reliably prevented. Finally, the second removable cooling fluid aperture covers 44 are, in addition, arranged in the third cooling fluid duct 36 over the second cooling fluid apertures 38 in order to occlude said third cooling fluid duct 36 in relation to the interior space of the trolley compartment 10. By this means, said third cooling fluid duct 36 is also protected against the penetration of dirt from the interior space of the trolley compartment 10.

In a non-cooled trolley compartment 10, the installation of a cooling device in the installation space 26 is dispensed with. In the case of a conversion of a trolley compartment 10 from a cooled trolley compartment 10 to a non-cooled trolley compartment 10, a cooling device installed in the installation space 26 can be demounted for weight-saving reasons, but may also be left in said installation space 26 if desired.

If the trolley compartment 10 is to be constructed as a cooled trolley compartment 10, on the other hand, the mounting of the first removable cooling fluid aperture covers 40 and the connecting aperture cover 42 in the first cooling fluid duct 28, as well as the mounting of the second removable cooling fluid aperture covers 44 in the third cooling fluid duct 36, are dispensed with. In the case of a conversion of the trolley compartment 10 from a non-cooled trolley compartment 10 to a cooled trolley compartment 10, the first removable cooling fluid aperture covers 40 and the connecting aperture cover 42 are demounted from the first cooling fluid duct 28, and the second removable cooling fluid aperture covers 44 are demounted from the third cooling fluid duct 36.

Instead of this, first removable fluid-permeable, grille-type cooling fluid aperture covers 46 are positioned in the first cooling fluid duct 28 over the first cooling fluid apertures 30 (see Figure 4). The second cooling fluid apertures 38 are covered by second removable fluid-permeable, grille-type cooling fluid aperture covers 48 which are positioned in the third cooling fluid duct 36 over the second cooling fluid apertures 38 (see Figure 2). The first removable fluid-permeable, grille-type cooling fluid aperture covers 46 and the second removable fluid-permeable, grille-type

cooling fluid aperture covers 48 permit the passage of cooling fluid, but hold back dirt, so that the first cooling fluid duct 28 and the third cooling fluid duct 36 are protected against the penetration of dirt from the interior space of the trolley compartment 10, even if said trolley compartment 10 is constructed as a cooled trolley compartment 10.

If the trolley compartment 10 shown in the figures is constructed as a cooled trolley compartment 10, the third cooling fluid duct 36 serves as a cooling fluid feed duct for feeding cooling fluid from a cooling fluid outlet of a cooling device installed in the installation space 26 into the interior space of said trolley compartment 10. The first cooling fluid duct 28, on the other hand, forms a section of a cooling fluid discharge duct for discharging cooling fluid, which has been warmed up on flowing through the trolley compartment 10, from the interior space of said trolley compartment 10.

Cooling fluid passing out of the first cooling fluid duct 28 via the connecting aperture 34 is fed, via the second cooling fluid duct 32, to a cooling fluid inlet of the cooling device installed in the installation space 26. If desired, however, the direction of flow of the cooling fluid through the trolley compartment 10 can also be reversed, i.e. cooling fluid may be fed from a cooling fluid outlet of a cooling device installed in the installation space 26, via the second cooling fluid duct 32 and the first cooling fluid duct 28, into the interior space of the trolley compartment 10, and discharged from said interior space of the trolley compartment 10 via the third cooling fluid duct 36.

Finally, Figures 5 to 7 illustrate the fact that the worktop 14 is of multilayer makeup and comprises a first layer 50. Said first layer 50 is separated by spacers 52 from a second layer 54. A table which can be pulled out (not shown in Figures 5 to 7) is arranged in a cavity formed by the spacers 52 between the first and second layers 50, 54. When the table is in its pulled-out position, it enlarges the working surface formed by the upper side of the worktop 14. In its inoperative position, on the other hand, it is integrated into said worktop 14 and requires no additional installation space. In the arrangement of Figure 5, the first cooling fluid duct 28 is integrated into the first layer 50 of the worktop 14.

A second embodiment of an on-board kitchen 100 which is shown in Figure 8 differs from the arrangement depicted in Figure 1 only in that a free space 58 is defined between a lower edge 60 of the partition 24 and a floor 62 of the trolley compartment 10. In other words, the partition 24 does not extend all the way down to the floor 62 of the trolley compartment 10. Thus, cooling fluid may circulate

between the two sections of the trolley compartment interior space which are separated from one another by the partition 24. Otherwise the structure and the function of the on-board kitchen 100 according to Figure 8 correspond to the structure and the function of the on-board kitchen 100 shown in Figure 1.

Patent claims

1. Trolley compartment (10) for an on-board kitchen (100) intended for
5 installation in a means of transport, which trolley compartment comprises:
- a frontal access aperture (16) as well as a rear wall (18) that lies opposite said
access aperture (16);
- a worktop (14) which forms an upper boundary of the trolley compartment (10);
- a first cooling fluid duct (28) which is integrated into or arranged adjacent to the
10 worktop (14) and which is connectable to an interior space of the trolley
compartment (10) via at least one first cooling fluid aperture (30); and
- at least one first removable cooling fluid aperture cover (40) which is selectively
mountable in the first cooling fluid duct (28) over the first cooling fluid aperture (30)
in order to separate said first cooling fluid duct (28) from the interior space of the
15 trolley compartment (10), or demountable from the first cooling fluid duct (28) in
order to connect said first cooling fluid duct (28) to the interior space of the trolley
compartment (10) via the first cooling fluid aperture (30).
2. Trolley compartment according to Claim 1,
20 which further comprises a first removable fluid-permeable, grille-type cooling fluid
aperture cover (46) which is selectively mountable in the first cooling fluid duct (28)
over the first cooling fluid aperture (30), or demountable from said first cooling fluid
duct (28).
3. Trolley compartment according to Claim 1 or 2,
25 which further comprises a second cooling fluid duct (32) which is connectable to the
first cooling fluid duct (28) via a connecting aperture (34) provided in said first
cooling fluid duct (28), wherein the second cooling fluid duct (32) is integrated, in
particular, into a sidewall (20, 22) or a partition (24) of the trolley compartment (10).
30
4. Trolley compartment according to Claim 3,
which further comprises a removable connecting aperture cover (42) which is
selectively mountable in the first cooling fluid duct (28) over the connecting aperture
(34) in order to separate said first cooling fluid duct (28) from the second cooling
35 fluid duct (32), or demountable from the first cooling fluid duct (28) in order to
connect said first cooling fluid duct (28) to the second cooling fluid duct (32) via the
connecting aperture (34).

5. Trolley compartment according to Claim 3 or 4,
which further comprises an installation space (26) for a cooling device, which
installation space is connected to the second cooling fluid duct (32), wherein the
5 installation space (26) for a cooling device is integrated, in particular, into a sidewall
(20, 22) or a partition (24) of the trolley compartment (10).

6. Trolley compartment according to Claim 5,
which further comprises a third cooling fluid duct (36) which is connected to the
10 installation space (26) for a cooling device and which is connectable to the interior
space of the trolley compartment (10) via a second cooling fluid aperture (38),
wherein said third cooling fluid duct (36) is integrated, in particular, into a sidewall
(20, 22) or a partition (24) of the trolley compartment (10).

7. Trolley compartment according to Claim 6,
15 wherein a free space (58) is defined between a lower edge (60) of the partition (24)
and a floor (62) of the trolley compartment (10).

8. Trolley compartment according to Claim 6 or 7,
20 which further comprises a second removable cooling fluid aperture cover (44) which
is selectively mountable in the third cooling fluid duct (36) over the second cooling
fluid aperture (38) in order to separate said third cooling fluid duct (36) from the
interior space of the trolley compartment (10), or demountable from the third cooling
fluid duct (36) in order to connect said third cooling fluid duct (36) to the interior
25 space of the trolley compartment (10) via the second cooling fluid aperture (38).

9. Trolley compartment according to one of Claims 6 to 8,
which further comprises a second removable fluid-permeable, grille-type cooling fluid
aperture cover (48) which is selectively mountable in the third cooling fluid duct (36)
30 over the second cooling fluid aperture (38), or demountable from said third cooling
fluid duct (36).

10. Trolley compartment according to one of Claims 1 to 9,
wherein the worktop (14) comprises a first layer (50) as well as a second layer (54)
which is separated from the first layer (50) by spacers (52).

5

11. Trolley compartment according to Claim 10,
wherein the first cooling fluid duct (28) is integrated into the first layer (50) of the
worktop (14).

10

12. Trolley compartment according to Claim 10 or 11,
wherein a pull-out table is arranged in a cavity (56) formed by the spacers (52)
between the first and second layers (50, 54) of the worktop (14).

15

13. Trolley compartment according to one of Claims 1 to 12,
which is provided with an insulating layer (27) in the region of at least one sidewall
(20, 22) and/or its rear wall (18).

20

14. On-board kitchen (100) for installation in a means of transport, which kitchen
comprises a trolley compartment (10) according to one of Claims 1 to 13.

15. Use, in an aircraft, of a trolley compartment (10) according to one of Claims 1
to 13 and/or an on-board kitchen (100) according to Claim 14.

FIG 1

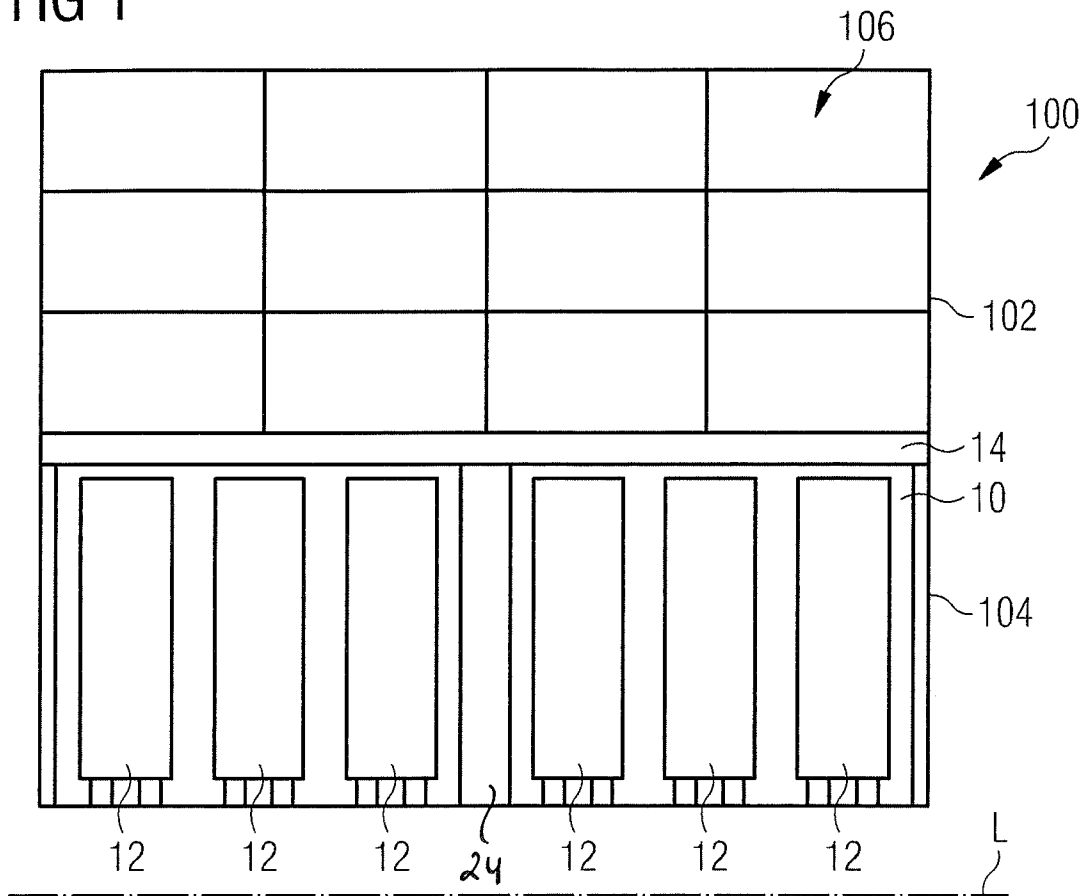

FIG 2

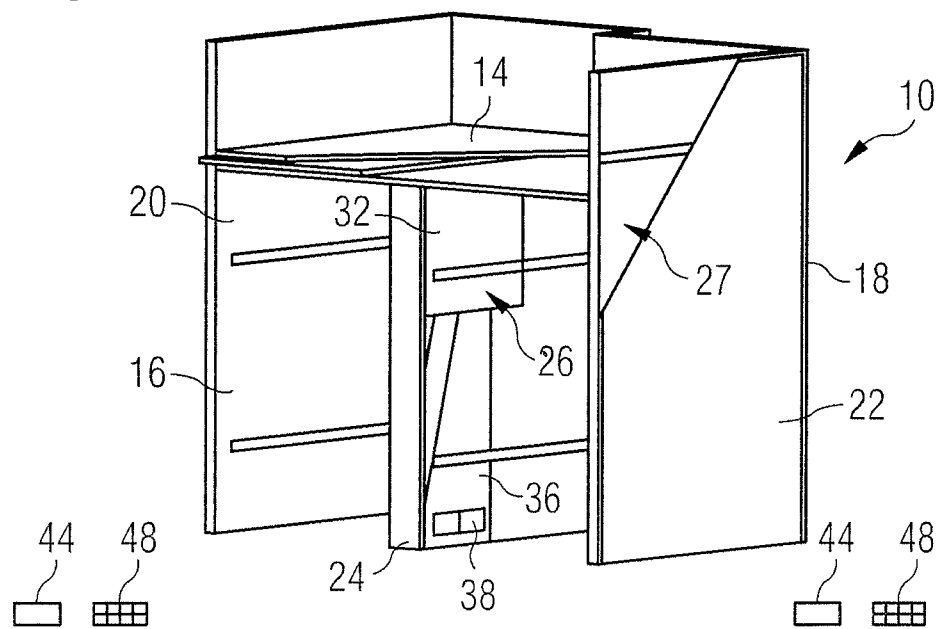

FIG 3

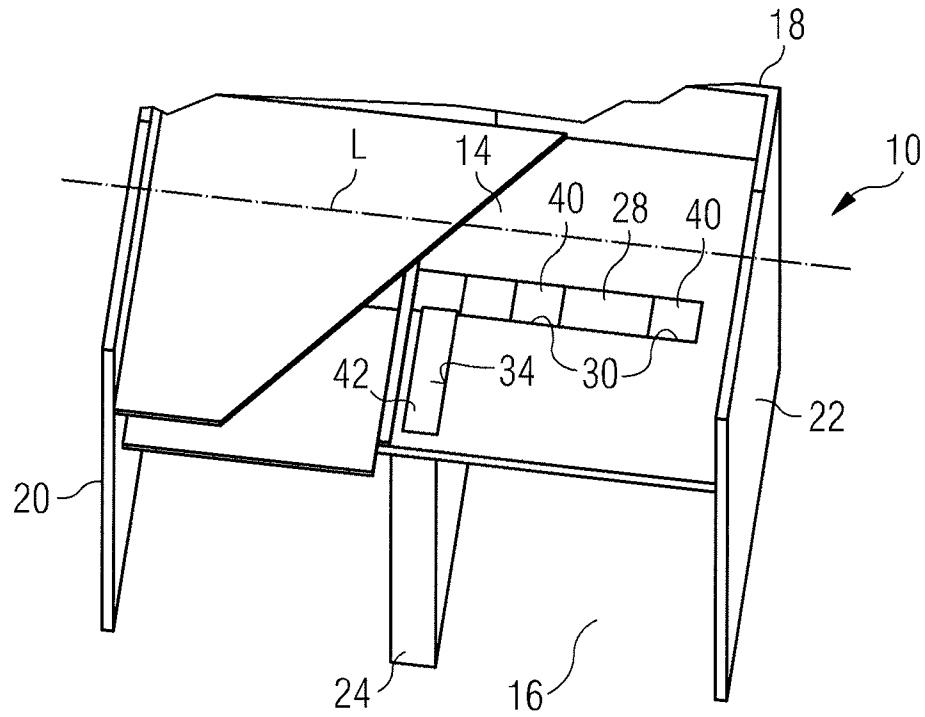

FIG 4

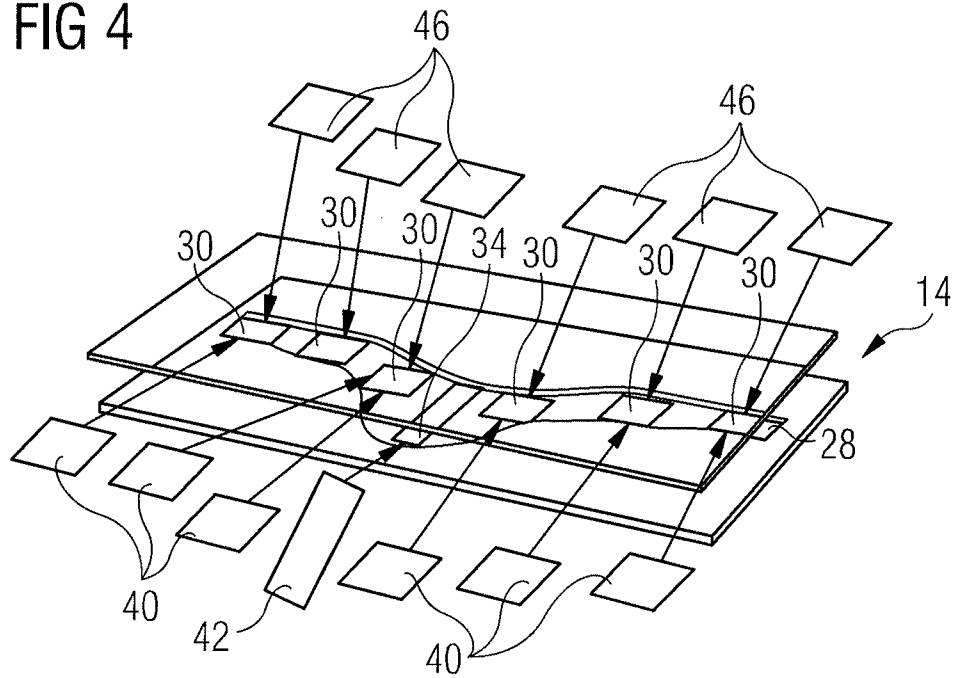

FIG 5

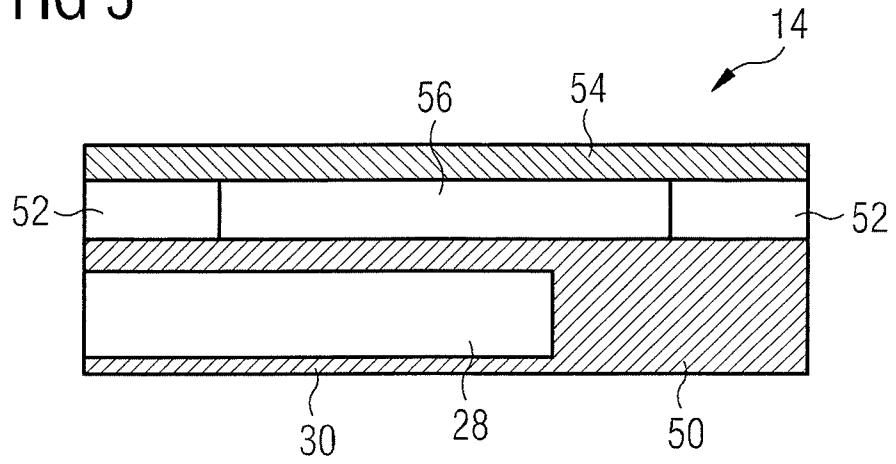
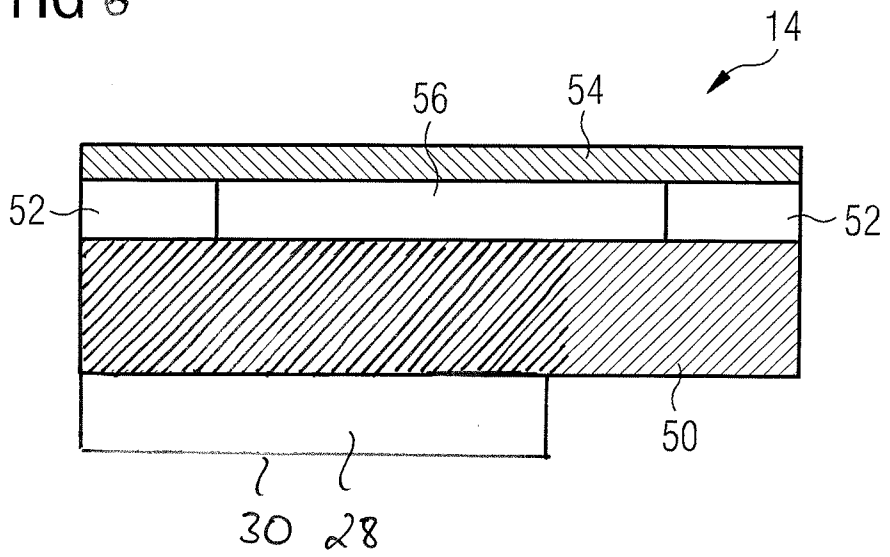
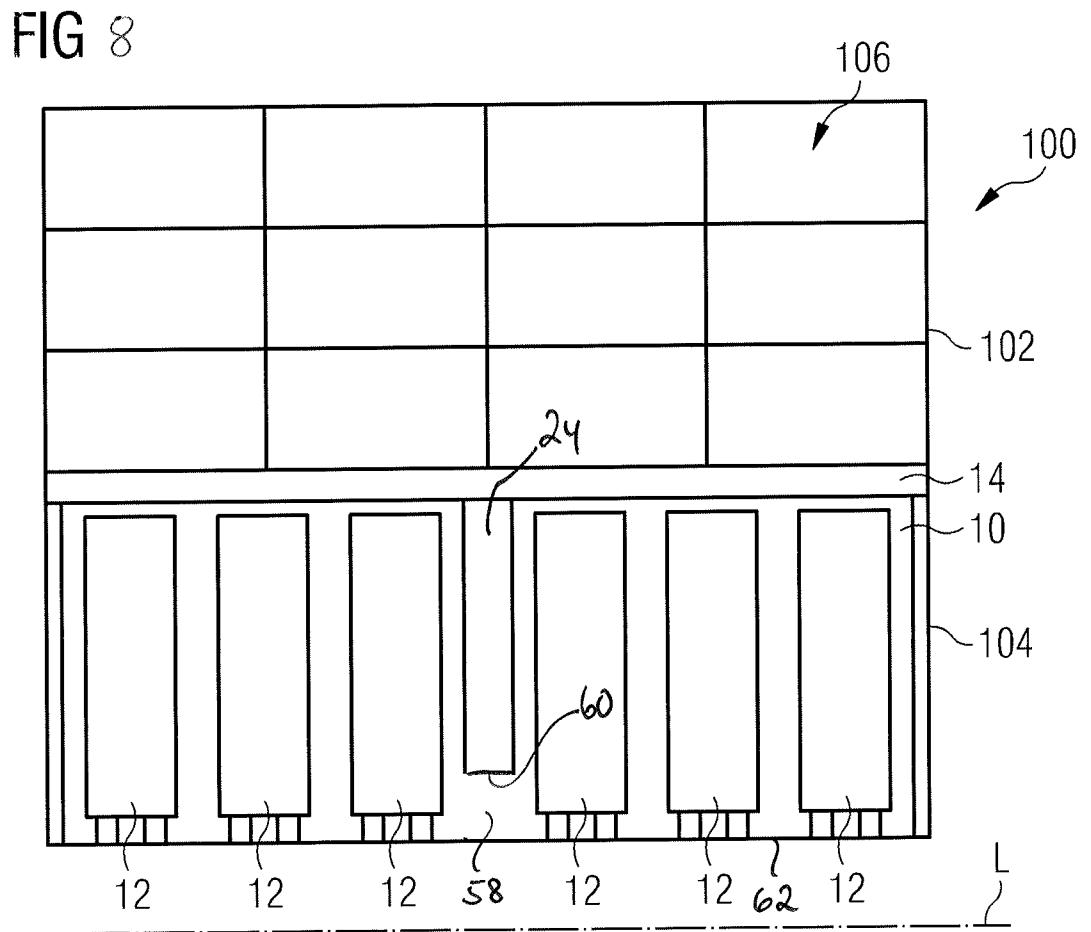
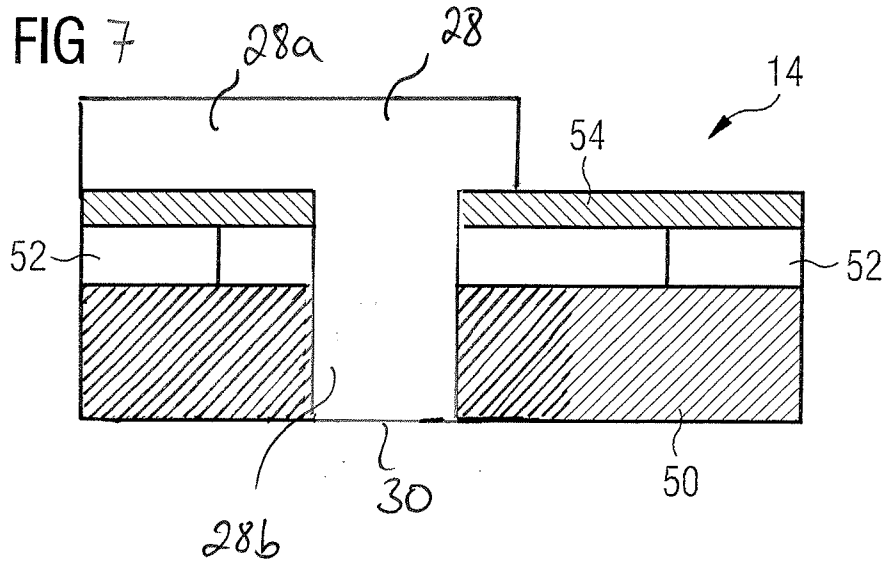

FIG 6





INTERNATIONAL SEARCH REPORT

International application No
PCT/EP2016/062485

A. CLASSIFICATION OF SUBJECT MATTER
 INV. B64D11/00 B64D11/04
 ADD.
 According to International Patent Classification (IPC) or to both national classification and IPC

B. FIELDS SEARCHED
 Minimum documentation searched (classification system followed by classification symbols)
 B64D

Documentation searched other than minimum documentation to the extent that such documents are included in the fields searched

Electronic data base consulted during the international search (name of data base and, where practicable, search terms used)
 EPO-Internal, WPI Data

C. DOCUMENTS CONSIDERED TO BE RELEVANT

Category*	Citation of document, with indication, where appropriate, of the relevant passages	Relevant to claim No.
A	US 2013/269384 A1 (BURD PETER JOHN LESLIE [GB]) 17 October 2013 (2013-10-17) paragraph [0026] - paragraph [0040]; figures	1-15
A	US 5 491 979 A (KULL HARALD [DE] ET AL) 20 February 1996 (1996-02-20) column 3, line 23 - column 5, line 33; figures	1-15

Further documents are listed in the continuation of Box C.

See patent family annex.

* Special categories of cited documents :

- "A" document defining the general state of the art which is not considered to be of particular relevance
- "E" earlier application or patent but published on or after the international filing date
- "L" document which may throw doubts on priority claim(s) or which is cited to establish the publication date of another citation or other special reason (as specified)
- "O" document referring to an oral disclosure, use, exhibition or other means
- "P" document published prior to the international filing date but later than the priority date claimed

- "T" later document published after the international filing date or priority date and not in conflict with the application but cited to understand the principle or theory underlying the invention
- "X" document of particular relevance; the claimed invention cannot be considered novel or cannot be considered to involve an inventive step when the document is taken alone
- "Y" document of particular relevance; the claimed invention cannot be considered to involve an inventive step when the document is combined with one or more other such documents, such combination being obvious to a person skilled in the art
- "&" document member of the same patent family

Date of the actual completion of the international search 27 July 2016	Date of mailing of the international search report 08/08/2016
---	--

Name and mailing address of the ISA/ European Patent Office, P.B. 5818 Patentlaan 2 NL - 2280 HV Rijswijk Tel. (+31-70) 340-2040, Fax: (+31-70) 340-3016	Authorized officer Silva d'Oliveira, M
--	---

INTERNATIONAL SEARCH REPORT

Information on patent family members

International application No PCT/EP2016/062485

Patent document cited in search report		Publication date		Patent family member(s)	Publication date
US 2013269384	A1	17-10-2013		CA 2868287 A1	03-10-2013
				CN 104507804 A	08-04-2015
				EP 2830942 A1	04-02-2015
				JP 2015519240 A	09-07-2015
				US 2013269384 A1	17-10-2013
				WO 2013149143 A1	03-10-2013

US 5491979	A	20-02-1996		DE 4340316 A1	01-06-1995
				EP 0655592 A1	31-05-1995
				JP H07225074 A	22-08-1995
				RU 2106584 C1	10-03-1998
				US 5491979 A	20-02-1996
