



- (51) **International Patent Classification:**
B09B 3/00 (2006.01) *F24D 7/00* (2006.01)
B09B 5/00 (2006.01) *F24D 15/00* (2006.01)
C10J 3/00 (2006.01)
- (21) **International Application Number:**
PCT/EP2015/050369
- (22) **International Filing Date:**
9 January 2015 (09.01.2015)
- (25) **Filing Language:** English
- (26) **Publication Language:** English
- (30) **Priority Data:**
1400422.0 10 January 2014 (10.01.2014) GB
1400834.6 17 January 2014 (17.01.2014) GB
1403814.5 4 March 2014 (04.03.2014) GB
- (71) **Applicant: MANIK VENTURES LIMITED** [GB/GB];
Offenham Road, Worcestershire, Evesham WR11 8DX (GB).
- (72) **Inventors: SPENCER, Nik**; Morton Spiert Farm, Abbots Morton, Worcesetrshire WR7 4NA (GB). **GIBBON, Matthew**; Offenham Road, Evesham, Worcestershire WR11 8DX (GB). **JOUHARA, Hussam**; 199 Wilbraham Road, Manchester M14 7DT (GB).

- (74) **Agent: DOWNING, Michael Philip**; Downing Intellectual Property LLP, Oak House, Oak End Way, Gerrards Cross, Buckinghamshire SL9 8BR (GB).
- (81) **Designated States** (*unless otherwise indicated, for every kind of national protection available*): AE, AG, AL, AM, AO, AT, AU, AZ, BA, BB, BG, BH, BN, BR, BW, BY, BZ, CA, CH, CL, CN, CO, CR, CU, CZ, DE, DK, DM, DO, DZ, EC, EE, EG, ES, FI, GB, GD, GE, GH, GM, GT, HN, HR, HU, ID, IL, IN, IR, IS, JP, KE, KG, KN, KP, KR, KZ, LA, LC, LK, LR, LS, LU, LY, MA, MD, ME, MG, MK, MN, MW, MX, MY, MZ, NA, NG, NI, NO, NZ, OM, PA, PE, PG, PH, PL, PT, QA, RO, RS, RU, RW, SA, SC, SD, SE, SG, SK, SL, SM, ST, SV, SY, TH, TJ, TM, TN, TR, TT, TZ, UA, UG, US, UZ, VC, VN, ZA, ZM, ZW.
- (84) **Designated States** (*unless otherwise indicated, for every kind of regional protection available*): ARIPO (BW, GH, GM, KE, LR, LS, MW, MZ, NA, RW, SD, SL, ST, SZ, TZ, UG, ZM, ZW), Eurasian (AM, AZ, BY, KG, KZ, RU, TJ, TM), European (AL, AT, BE, BG, CH, CY, CZ, DE, DK, EE, ES, FI, FR, GB, GR, HR, HU, IE, IS, IT, LT, LU, LV, MC, MK, MT, NL, NO, PL, PT, RO, RS, SE, SI, SK, SM, TR), OAPI (BF, BJ, CF, CG, CI, CM, GA, GN, GQ, GW, KM, ML, MR, NE, SN, TD, TG).

Declarations under Rule 4.17:

— as to the identity of the inventor (Rule 4.17(i))

[Continued on next page]

(54) **Title:** A PYROLYSIS CHAMBER FOR TREATING DOMESTIC REFUSE AND DWELLING EQUIPPED WITH SUCH A CHAMBER

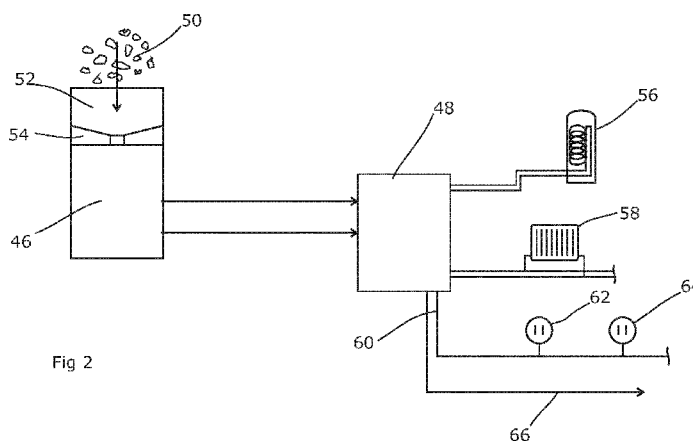

Fig 2

(57) **Abstract:** Existing approaches to refuse handling are all based on historical approaches which rely on a network of refuse collection vehicles collecting waste from individual households and delivering this to a centralised landfill or MBI location. This is highly undesirable and wasteful. An alternative process is disclosed, relying on the thermal treatment of waste and like products produced or brought in to the residential property and processed within the domestic curtilage to produce fuel or other forms of energy. Thus, domestic waste will be thermally treated at the home instead of being collected by local authorities and disposed of. The waste input material will be loaded into a domestically engineered thermal conversion unit either directly or after a pre-process such as shredding. The feedstock will be converted into fuels by a thermal treatment, such as pyrolysis. The resultant output of oil and gas can either be stored or fed into a boiler unit to be used as a fuel to produce hot water, or used to run an electricity generating unit to power the dwelling in question or for supply to a feed-in tariff. Thus, a domestic dwelling includes a thermal treatment unit for processing waste produced in the dwelling, an output of the thermal treatment unit being combusted for producing an energy output for the dwelling. A suitable pyrolysis chamber is disclosed.



- *as to applicant's entitlement to apply for and be granted a patent (Rule 4.17(ii))*
- *of inventorship (Rule 4.17(iv))*
- *as to the applicant's entitlement to claim the priority of the earlier application (Rule 4.17(iii))*
- *with international search report (Art. 21(3))*

Published:

A PYROLYSIS CHAMBER FOR TREATING DOMESTIC REFUSE AND DWELLING EQUIPPED WITH SUCH A CHAMBER

FIELD OF THE INVENTION

The present invention relates to the disposal of refuse, especially refuse from domestic dwellings and smaller commercial establishments.

5 BACKGROUND ART

The domestic households of the United Kingdom collectively generate approximately 30 million tonnes of waste per year. Typically, 40% of this is recyclable – such as paper, cardboard, glass, cans plastics and (in some cases) green waste and food waste. This waste is collected from the majority of households via a kerbside type collection scheme
10 operated by or on behalf of local government bodies. Existing UK practice is to require householders to divide waste into separate containers for the various types of recyclable waste, to allow these to be harvested with the remainder being classed as residual waste. The waste is collected either weekly or fortnightly, and the residual waste is either landfilled or sent to large scale Energy from Waste plants to generate electricity.

15 The current approach is that waste is collected in Refuse Collection Vehicles (RCV) and disposed of through large-scale Energy from Waste (EfW) incinerators or Mass Burn Incinerators (MBI). These can process circa 200k to 300k tonnes of waste per annum. These MBIs use existing proven technology which makes them attractive to the financial markets to fund the capital cost of the plant when combined with long term waste disposal
20 contracts with the County Councils who are responsible for the disposal and treatment of waste generated by their residents.

On the fringes there are alternative thermal treatment technologies emerging, such as gasification, pyrolysis and plasma, which effectively break down the waste to a synthesised gas (Syngas) and fuel product. The gas and oil can then be utilised to run
25 electrical generating equipment. These technologies are still in their relative infancy but do have substantial environmental benefits; they are cleaner than the conventional incinerators and although smaller than MBIs their capacity is still substantial, circa 15k to 30k tonnes per annum. However, it is not yet clear that these units will be able to scale their capacity up to a commercially viable size.

US 2007/0099039A1 discloses an appliance for converting household waste into energy, in which syngas is used to power a fuel cell for the generation of electric power, steam and heat or cooling for use in residences and buildings. A waste conversion reactor that applies a steam reforming process to the waste is heated with a combination of waste
5 heat and electrical power or a natural gas burner. To our knowledge, this steam reforming process has not been shown to be practically usable, especially in a domestic context.

SUMMARY OF THE INVENTION

The currently-viable approaches to refuse handling are all based on historical approaches which rely on a network of RCVs collecting waste from individual households
10 and delivering this to a centralised landfill or MBI location. This is highly undesirable and wasteful. A substantial investment needs to be made in a fleet of RCVs, which also incurs significant running costs. The process of operating these vehicles introduces a range of health & safety issues; injuries can result from the lifting, moving and handling work that is required, and road traffic incidents arise through placing operatives in the roadway around
15 both routine traffic and the RCV itself. A location needs to be found for the landfill or MBI, which needs to comply with local planning or zoning laws and which usually meets with resistance from nearby residents. To obtain an acceptable site for the landfill or MBI, a remote location with few immediate neighbours is usually needed, thereby increasing the running costs and associated emissions of the RCV fleet. These historic approaches also
20 assume that there is a ready market for recyclable materials, which has previously been provided by demand from Asian countries. However, as those countries become more self-sufficient in collecting and processing their own recyclable waste, this market is declining.

The present invention therefore proposes the thermal treatment of waste and like products produced or brought in to the residential property and processed within the
25 domestic curtilage to produce fuel or other forms of energy. Thus, domestic waste will be thermally treated at the home instead of being collected by local authorities and disposed of.

The waste input material will be loaded into a domestically engineered thermal conversion unit either directly or after a pre-process such as shredding. The feedstock will be converted into fuels by a thermal treatment, such as pyrolysis. The resultant output of
30 oil and gas can either be stored, or fed into a boiler unit (or combusted in situ) to be used as a fuel to produce hot water, or used to run an electricity generating unit to power the

dwelling in question. It can also be used as a fuel to assist in obtaining the temperatures needed for the pyrolysis process, thereby reducing the energy demands of the unit. Some or all of the electricity generated, or of the oil and/or gas output, could be exported for supply to a feed-in tariff, for use elsewhere.

5 In one aspect, the present invention therefore proposes a domestic dwelling including a thermal treatment unit for processing waste produced in the dwelling, an output of the thermal treatment unit being combusted for producing an energy output for the dwelling. The output of the thermal treatment unit can include syngas (synthesis gas) and/or oil; this can be combusted in situ or fed to a separate combustor. One advantage of
10 a separate combustor is that it can be adapted to receive a second fuel in addition to the combustible output, for example in order to allow continuity of fuel supply regardless of the amount of waste being processed. The combustor will often be a furnace (or boiler as referred to in the UK) connected to pipework installed within the dwelling for heating water circulating within the pipework. That water can be used to heat radiators and/or a hot
15 water supply for the dwelling. Alternatively, the combustor may be an electrical generator or a combined heat and power unit.

The output of the thermal treatment unit often includes a residue, so the thermal treatment unit can have a connection to a sewerage system to allow disposal thereof.

20 In another aspect, the present invention provides a pyrolysis chamber for treating domestic refuse, comprising a receptacle for the refuse, the receptacle being defined by a double-skinned enclosure having an exterior wall, an interior heat-conductive wall, and a void between the two walls in which a working fluid is disposed, and at least one heating element in thermal contact with the enclosure.

25 The double-skinned arrangement with a working fluid within the void creates a chamber with a very uniform temperature distribution, which assists the pyrolysis process. The enclosure preferably also includes at least one heat-conductive pin extending from the interior wall into the interior of the receptacle, to create a more uniform temperature distribution within the interior of the chamber and especially within the interior of the initially-cold refuse placed within the chamber. The at least one pin is preferably hollow,
30 and the hollow interior of the pin is ideally in fluid communication with the void in order to share the heat-transmitting capabilities of the fluid.

The receptacle preferably also includes at least one leg extending from the exterior wall, and a heat source connected to the leg in order to introduce heat into the chamber and elevate the temperature to a level sufficient for pyrolysis. The at least one leg is ideally hollow, with the hollow interior of the leg being in fluid communication with the void
5 in order to provide a high degree of thermal communication with the remainder of the chamber. The heat source can be an electrical heating element, or a heat exchanger, which may be supplied with waste heat recovered from the current or previous pyrolysis cycles. Multiple such legs may be provided, each with a heat source. A range of different heat sources may be provided on different legs.

10 The enclosure is preferably formed of stainless steel in order to provide the necessary thermal, mechanical and corrosion properties.

The working fluid need not completely fill the void; an expansion gap may be provided which can be evacuated, or filled with an inert gas, or filled with air. The working fluid can be Dowtherm A™ or (liquid) sodium; generally Dowtherm A™ is preferred for
15 temperatures up to about 400°C whereas sodium is preferable above this level.

BRIEF DESCRIPTION OF THE DRAWINGS

An embodiment of the present invention will now be described by way of example, with reference to the accompanying figures in which;

Figure 1 shows a typical domestic dwelling in which the present invention has been
20 installed;

Figure 2 shows a system schematic according to the present invention;

Figure 3 shows a side view of a pyrolysis chamber according to the present invention;

Figure 4 shows a vertical section through figure 3, on line IV-IV;

25 Figure 5 shows a horizontal section through figure 3, on line V-V;

Figure 6 shows a horizontal section through figure 3, on line VI-VI;

Figure 7 shows an enlarged version of region VII on figure 4; and

Figure 8 is a process flowchart.

DETAILED DESCRIPTION OF THE EMBODIMENTS

The current systems of domestic refuse collection and disposal still rely on one common thread - that waste needs to be collected from every household. Collecting waste is expensive, not only in terms of the immediate costs of collection, disposal and/or processing, but also in terms of national or regional environmental taxes relating to dispose of waste; in the United Kingdom this amounts to approximately £90 per tonne. The industry trend is in making improvements in the handling of the waste after it has been collected and taken to a processing site – improvements such as better sorting of the waste to increase recycling rates, and/or alternative disposal methods such as mass-burn incinerators (MBIs) and thermal treatment methods including pyrolysis and plasma treatment. However, MBIs are expensive, and the emerging thermal technologies have not been demonstrated to be capable of being scaled up to an economically viable capacity.

According to the present invention, such thermal technologies are scaled down, instead of up. Instead of a large unit at a processing site to which the refuse must be transported, the invention provides a domestic unit, located at the house, to process the waste produced in that house. Waste is put into a domestic thermal treatment unit, ideally about the size of a white-goods appliance, which would process the waste and generate waste oil and syngas. The oil and syngas could then fuel a domestic boiler, probably supplemented by a natural gas supply in order to ensure a stable supply. Alternatively, or in addition, the oil and gas could be used to run a small-scale electricity generating unit to produce electrical power. This could then be stored via batteries and used when required, or fed into the household power mains, or fed into the local electrical grid via a feed-in tariff. So-called "micro combined heat and power" are available for domestic use and produce a combination of heat for the dwelling and an electrical power output. The combination of energy generated from waste and solar technology to generate electricity during the day, along with new efficient building design, could make houses self-sufficient in time. The thermal treatment unit will also provide a direct heat output which can be piped throughout the house as a process by-product, or integrated into the heating capability of the boiler, or used to drive an electrical generation unit directly.

A small-scale unit of this type could use one or more of plasma, pyrolysis and cracking type technologies, although we believe pyrolysis to be the most practical. These take a mixed homogeneous material stream and use thermal and pressure based processes to reduce the waste composition back to 3 component parts - oil, gas and carbon. Pyrolysis technologies that are currently available use heat in the absence of air to decompose the molecular composition of the material. Plasma gasification is a process which converts organic matter into synthetic gas, electricity, and a solid residue using plasma. A plasma torch powered by an electric arc is used to ionize gas and catalyse the conversion of organic matter into synthetic gas and solid waste.

The waste can be shredded in order to make it more suitable for processing in the unit. A receptacle for the waste, either before or after a shredder, will help smooth the flow of waste into the unit.

Figure 1 shows a domestic dwelling-house 10 in which the system is installed. A roadway 12 has a pavement (or sidewalk) 14 over which access can be gained to a driveway 16 in front of the house 10. A walkway 18 alongside the driveway 16 allows access to a front door at the front of the house 10. A perimeter fence 20 extends along one side 22 of the property 24 in which the house 10 is located, then along the rear boundary 26, and along the opposite side boundary 28 as far as the pavement 14. Together with the pavement 14, the perimeter fence 20 provides a visible definition to the boundary of the property 24.

The house 10 itself has an external wall 30 and internal walls 32 defining individual rooms within the house, including a hallway 34 into which the front door opens, a sitting room 36, a dining room 38, a kitchen 40, and a garage 42 which opens onto the driveway 16. Stairs 44 lead upwards from the hallway 34 to an upper floor with bedrooms and one or more bathrooms. The house may of course be arranged differently and have more or fewer rooms.

A thermal treatment unit 46 is located adjacent the house 10, against the external wall 30. It is located near to the kitchen 40 where most of the waste is produced, for the convenience of the householder. As noted above, the thermal treatment unit 46 produces an output that is a combination of syngas and combustible oils, these are fed to a boiler 48 which (in this case) is in the conventional location within the garage 42. The boiler

supplements the output of the thermal treatment unit 46 when necessary with a natural gas supply, and burns these fuels in order to generate heat for the house 10 in a conventional manner. This is shown in figure 2; waste 50 is placed in a receptacle 52 in the thermal treatment unit 46, and passes through a shredder 54 before being treated. The output of
5 the treatment unit 46 is then fed to the boiler 48 and is used to heat a working fluid (usually water) that is circulated around one or more heating circuits. The circuit may include a hot water tank 56 containing water that is then heated for use within the house 10, and/or a number of radiators 58 for warming the house 10.

The boiler 48 may be in the form of a micro-combined-heat-and-power unit, and
10 thus may also have an electrical output 60 leading (eventually) to one or more electrical outlets 62, 64 within the house. The or another electrical output 66 may also lead to a connector for a feed-in tariff, in which locally generated power is fed into the wider electrical grid.

Of course, the thermal treatment unit 46 and the boiler 48 may be integrated into a
15 single unit that accepts waste 50 and (in all likelihood) an alternative power source (such as a natural gas supply), and creates heat and/or power for the house 10. Likewise, the unit or units may be located differently within (or outside) the house.

Pyrolysis units typically leave a residue of carbonised material, usually as a light ash. This is inert, and can thus be flushed away via a sewerage system. The thermal treatment
20 unit 46 therefore has (in preferred arrangements) a connection to the household water supply and sewerage system for this purpose. An alternative is to drop the residue into a container for routine disposal by the householder.

This gives rise to a wide range of benefits. Fewer waste collections are needed, resulting in savings in the waste infrastructure and landfill usage, and reductions in the
25 greenhouse gas emissions from landfill sites. The emissions from refuse collection vehicles will also be reduced, as will the fossil fuels used by them, leading to reduced operating costs for local authorities and the potential for reductions in local taxes. At the same time, once the initial capital costs have been covered, energy bills for the households in question will be reduced corresponding to the heat and/or electrical power produced by the unit. Fossil fuel
30 usage by households and by the power generation facilities that supply them will also reduce.

Figures 3 to 7 illustrate a suitable pyrolysis chamber for use in the present invention. Thus, a generally cylindrical vessel 100 has circular side walls 102 and an integral base section 104. An open upper end is closeable during use by way of a lid 106, held in place via a hinge 108 on one side and a latch mechanism 110 opposite, to allow the lid to seal hermetically to the vessel 100. An inlet 112 is formed in the lid 106 to allow water for cooling and washing to be introduced, and a corresponding outlet 114 is provided on the base 104 of the vessel 100. If preferred, the inlet 112 could be provided elsewhere, such as on a side wall of the vessel 100. An exhaust port 116 is formed on the side of the vessel 100 to allow for extraction of the pyrolysis results, as will be explained below.

Within the vessel 100, there are five spikes 118 extending upwardly from the base 104, arranged in a square formation with four spikes at the corners of the square and one at the centre, the square being centred on the central axis of the cylindrical vessel. The diagonal of the square is approximately half the diameter of the cylindrical vessel 100, thus distributing the spikes 118 evenly around the interior of the vessel 100. The exhaust port 116 faces a side of the square, thereby minimising the effect of the spikes 118 on flow through the exhaust port 116. These spikes 118 fit between and into refuse that has been loaded into the vessel 100 and serve to introduce heat from the vessel surfaces into the bulk of the refuse, thus assisting with the pyrolysis process. More or fewer spikes could be provided as desired, with a greater number of spikes providing more effective heat transfer and a lesser number making loading of refuse into the vessel 100 easier. A narrower vessel 100 may require fewer spikes 118 in order to ensure temperatures adequate for pyrolysis at the middle of the vessel; indeed, it may be possible to omit the spikes 118 entirely. Likewise, the spikes 118 could be arranged differently, although symmetrical arrangements are to be preferred.

Four legs 120 extend from the exterior of the base 104; these are again arranged in a square pattern centred on the central axis of the cylindrical vessel, with each leg at a corner of the square and the diagonal of the square being approximately half the diameter of the cylindrical vessel 100. The square pattern of the legs 120 is however rotated 45° relative to the square pattern of the spikes 118; as a result the legs 120 and the spikes 118 are not directly aligned. Each leg has an associated heat source; for three legs the heat source is an electrical heater 122 with contacts 124, 126 through which electrical power is

supplied in order to heat the leg. The fourth leg is provided with a heat exchanger 128 which will be described further below.

The walls of the vessel 100 are formed in a double-skinned arrangement, including a thermally-conductive inner wall 130 and an outer wall 132. The outer wall 132 is ideally also thermally conductive; indeed as illustrated in figures 3 to 7 it is an integral structure with the inner wall 130. A high-grade stainless steel is suitable for the wall material as it is sufficiently rigid and thermally conductive, while offering resistance to corrosion due to the potentially harsh environment that may be created within the chamber 100 during pyrolysis. The outlet 114 and the exhaust port 116 extend from the inner wall 130, through the void 134 between the two walls, and through the outer wall 132. The spikes 118 and the legs 120 extend from the inner wall 130 or the outer wall 132, respectively, and are themselves hollow with their hollow interior 136 communicating with the void 134.

Within the void 134, and thus also within the hollow interiors 136 of the spikes 118 and the legs 120, there is a small amount of heat transfer fluid (not shown).

The walls of the waste treatment chamber are thus formed by a hermetically-sealed, passive two phase heat transfer system, which is partially filled with a small amount of working fluid, present inside the chamber in two phases (liquid and vapour). The working fluid is substantially the only substance in the chamber's enclosure and is ideally saturated under all thermal conditions of the chamber. The superior thermal characteristics of the chamber make use of the highly efficient heat transfer processes of evaporation and condensation to maximize the thermal energy transfer between the heat legs 120 at the bottom and inner walls 130 of the chamber 100 that are in direct contact with the waste to be treated. The heat applied on the four legs of the chamber section is conducted across the leg's walls, causing the working fluid in the enclosure to boil. In this way the working fluid absorbs the applied heat load, storing it at least partly as latent heat. The vapour then flows to the (cooler) walls above the level of the legs 120, where it can condense and release the latent heat. The heat then conducts through the thin liquid film and the metal wall 130 and into the waste treatment chamber. Within the void 134, the flow circuit is completed by the liquid being forced by gravity back to the legs 120 in the form of a thin liquid film where it can be re-evaporated. The working fluid within the enclosure is at a substantially constant temperature (called the working temperature); thus when the vapour

condenses on the inside walls of the chamber, it will keep these walls at the same temperature leading to the surfaces that will be in touch with the waste all being in a substantially single isothermal state.

The required working fluid volume will vary based on the thermal requirement, but is likely to be between 10% and 35% of the chamber's enclosure volume (i.e. the void 134 between the walls 130, 132 that form the chamber 100). Based on the required wall temperature of the chamber, the selection of the working fluid will be as follows:

- a. Sodium for chamber wall temperatures between 400°C and 700°C.
- b. Dowtherm A™ for chamber wall temperatures between 300°C and 400°C
- 10 c. Water for chamber wall temperatures below 300°C.

The Dowtherm A heat transfer fluid is described by its manufacturer at <http://www.dow.com/heattrans/products/synthetic/dowtherm.htm>, and is a eutectic mixture of biphenyl (C₁₂H₁₀) and diphenyl oxide (C₁₂H₁₀O). The fluid also includes a dye to give it a clear to light yellow colour, but this is purely to aid in leak detection and although useful, is not essential to the invention. Dowtherm A fluid is described as being useful in systems employing either liquid phase or vapor phase heating, including indirect heat transfer. Generally, Dowtherm A will be sufficient for the temperatures usually required for pyrolysis processes, but if higher temperatures are required then liquid sodium can be used. Dowtherm A is to be preferred, however, as it does not present an explosion risk if the double walls of the chamber are breached.

The double-walled nature of the vessel 100 and the heat transfer fluid within the void 134 ensure that an even and high temperature can be achieved across the vessel 100. The spikes 118 extend that even temperature into the interior of the vessel 100 and accelerate the pyrolysis process significantly. The legs 120, with their hollow interiors that can accept the heat transfer fluid, are an especially efficient way to convey heat to the remainder of the vessel 100.

The chamber will ideally be located within a suitable enclosure, which will also house the various supporting ancillaries such as control systems for the heating elements, etc.

Figure 8 shows a system diagram of the refuse treatment unit. The pyrolysis vessel 100 is opened via the lid 106 and pyrolisable refuse is placed inside. The lid 106 is closed and latched; oxygen is then removed from the vessel by either evacuation or displacement with an inert gas. The electrical heaters 122 are activated and the temperature within the vessel 100 is raised to a suitable temperature for pyrolysis, usually above about 170°C. As pyrolysis progresses, the chamber will yield water vapour and syngas via the exhaust port 116. This is passed to a multi-stage condensing and heat recovery unit 200, which essentially acts as a heat exchanger to heat water and/or air delivered via an inlet 202 and expelled via an outlet 204 to provide heated water and/or air for heating and/or sanitary use within the home or other building in which the unit is installed. As a result, the significant power requirements of the endothermic pyrolysis process is not wasted, but is re-used for other purposes thereby reducing the overall energy footprint of the device.

After heat recovery, the syngas and water mixture is further cooled, and thus separated by condensing of the water vapour, in a cooler 300. The syngas output of this cooler 300 is diverted via a valve 302 either to a storage tank 304 or to a combustion chamber 306 where the syngas can be burnt in a feed of air 308. Heat from the combusting syngas can then be supplied (using a suitable working fluid) to either the heat exchanger 128 on one or more legs 120 of the pyrolysis vessel 100 or to a waste heat recovery unit 400 via a valve 308. The waste heat recovery unit 400 also heats a domestic water or air supply 402 to produce a supply of hot water and/or air 404 for use in the same way as the hot water and/or air supply 204 above. The heat exchanger 128 and the waste heat recovery unit both vent any excess heat to a radiator 500 that releases the heat to the ambient environment; in addition, if necessary the heat output of the combustion chamber can be vented in the same way via a valve 310 prior to the waste heat recovery unit 400.

Thus, the pyrolysis chamber 100 requires a supply of refuse and heat; it outputs syngas, water vapour and heat. The output heat is recovered for domestic purposes, meaning that it may be preferable to store refuse in or near the pyrolysis unit until heating and/or hot water is needed. The syngas is extracted from the cooled output stream and can be stored until needed, or used immediately; once called upon it can be used to heat the building in question, or to contribute to the heat input called for by the vessel 100. In the latter case, the syngas can be stored for use in a later pyrolysis process, or may be used immediately in support of a later part of the current pyrolysis process.

Thus, the unit can be operated in a number of modes. Given that energy will be required to heat the building, that energy can be diverted to the pyrolysis process and then recovered to provide heating; together with the contribution from combusting syngas, this means that the net overall energy requirement of the unit could be very small.

5 Alternatively, the unit could be driven substantially entirely via electrical heating, from which heat can be recovered in order to heat the building and syngas could be generated to further heat the building. Either way, the domestic refuse is disposed of, reducing or eliminating the need for a doorstep refuse collection (with the concomitant environment

10 supply for the building.

Once pyrolysis is complete, water can be injected into the vessel via the inlet 112 to cool the vessel 100 to a safe temperature and flush out solid residues via the outlet 114. These residues may be usable as biofuel, depending on the nature of the refuse that was initially put into the unit. Careful control of the working temperature of the waste treatment

15 chamber should be sufficient to optimise the biofuel output.

It will of course be understood that many variations may be made to the above-described embodiment without departing from the scope of the present invention. For example, the thermal treatment unit, the shredder and/or the combustor could be adapted to utilise bio fuels. The combustor could be adapted to utilise natural gas or oil, and/or the

20 electricity generating unit could be adapted to supplement its output derived from the combustor with electricity derived from wind, solar or geothermal energy sources. The domestic radiators referred to above could be any system which uses heated water to raise the temperature in a dwelling, such as underfloor heating. Other than heating the dwelling directly, the system could provide indirect heating, such as by using the electricity generated

25 to operate a geothermal heating system via a heat pump. Furthermore, where different variations or alternative arrangements are described above, it should be understood that embodiments of the invention may incorporate such variations and/or alternatives in any suitable combination.

CLAIMS

1. A pyrolysis chamber for treating domestic refuse, comprising a receptacle for the refuse, the receptacle being defined by a double-skinned enclosure having an exterior wall, an interior heat-conductive wall, and a void between the two walls in which a working fluid is disposed, and at least one heating element in thermal contact with the enclosure.
5
2. A pyrolysis chamber according to claim 1 in which the enclosure includes at least one heat-conductive pin extending from the interior wall into the interior of the receptacle.
- 10 3. A pyrolysis chamber according to claim 2 in which the at least one pin is hollow, and the hollow interior of the pin is in fluid communication with the void.
4. A pyrolysis chamber according to any one of the preceding claims in which the receptacle includes at least one leg extending from the exterior wall, and a heat source connected to the leg.
- 15 5. A pyrolysis chamber according to claim 4 in which the at least one leg is hollow, and the hollow interior of the leg is in fluid communication with the void.
6. A pyrolysis chamber according to claim 4 or claim 5 in which the heat source is an electrical heating element.
7. A pyrolysis chamber according to claim 4 or claim 5 in which the heat source is a heat exchanger.
20
8. A pyrolysis chamber according to any one of claims 1 to 7 in which the enclosure is formed of stainless steel.
9. A pyrolysis chamber according to any one of claims 1 to 7 in which the working fluid does not completely fill the void.
- 25 10. A pyrolysis chamber according to any one of claims 1 to 7 in which the working fluid is one of water, Dowtherm A and Sodium.

11. A domestic dwelling including a pyrolysis unit for processing waste produced in the dwelling, an output of the pyrolysis unit being combusted for producing an energy output for the dwelling.
12. A dwelling according to any one of the preceding claims in which the pyrolysis unit includes a receptacle for the domestic waste.
13. A dwelling according to any one of the preceding claims in which the energy output includes a heated water supply for heating and/or sanitary use.
14. A dwelling according to any one of the preceding claims in which the energy output includes electrical power.
15. A dwelling according to any one of the preceding claims in which the output of the pyrolysis unit includes syngas and/or oil.
16. A dwelling according to any one of the preceding claims in which the output of the pyrolysis unit includes a residue, and the pyrolysis unit has a connection to a sewerage system to allow disposal of the residue.
17. A dwelling according to any one of the preceding claims in which the output of the pyrolysis unit is combusted in combination with a second fuel in addition.
18. A dwelling according to any one of the preceding claims including a furnace adapted to receive an output of the pyrolysis unit and being connected to pipework installed within the dwelling for heating water circulating within the pipework.
19. A dwelling according to any one of the preceding claims including an electrical generating unit adapted to receive an output of the pyrolysis unit and combust the output to produce electrical power, connected to an electrical power supply installed within the dwelling.
20. A dwelling according to claim 19 in which the electrical power supply includes a feed-in connector.
21. A domestic dwelling according to any one of claims 11 to 20 in which the pyrolysis unit includes a pyrolysis chamber according to any one of claims 1 to 10.

22. A domestic energy supply apparatus substantially as described herein with reference to and/or as illustrated in the accompanying drawings.

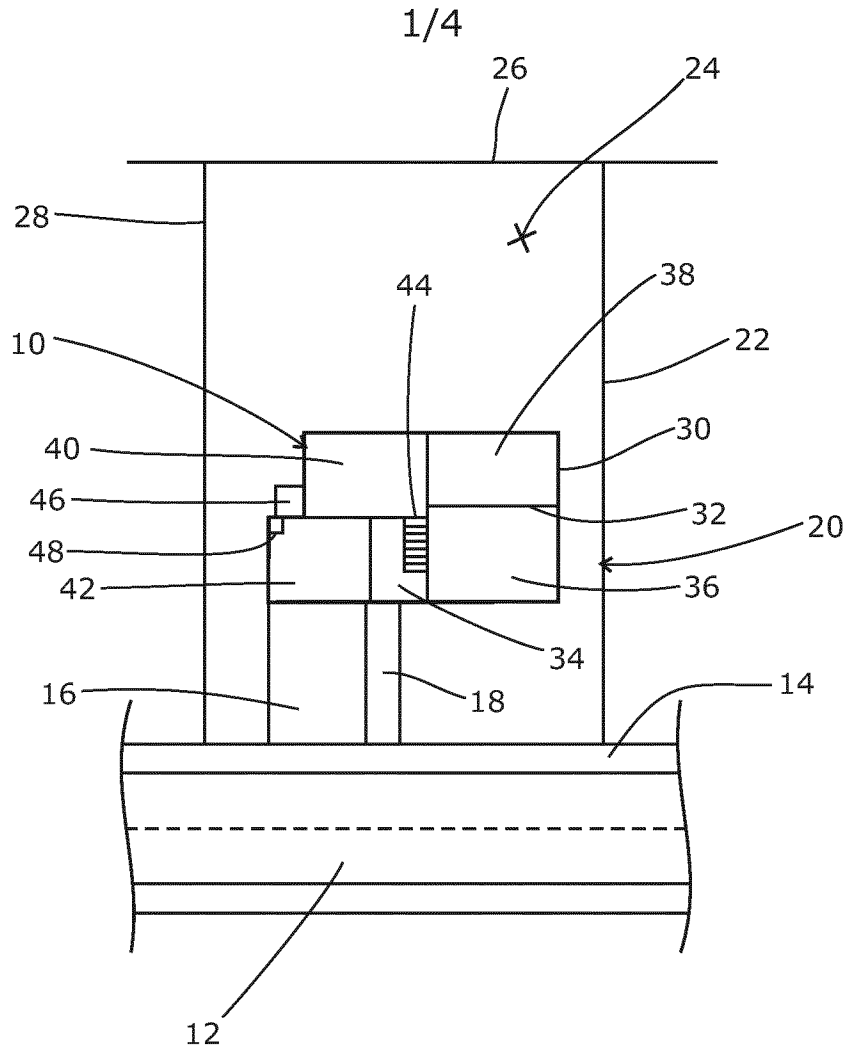

Fig 1

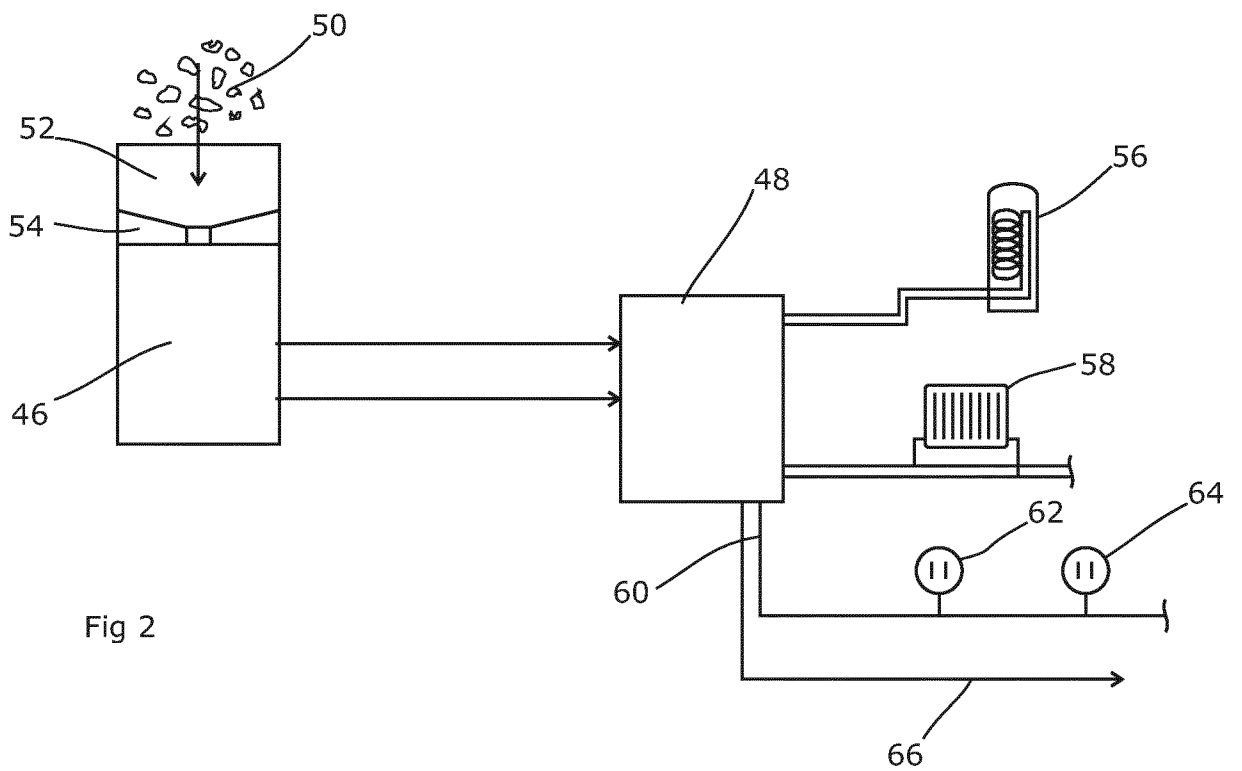
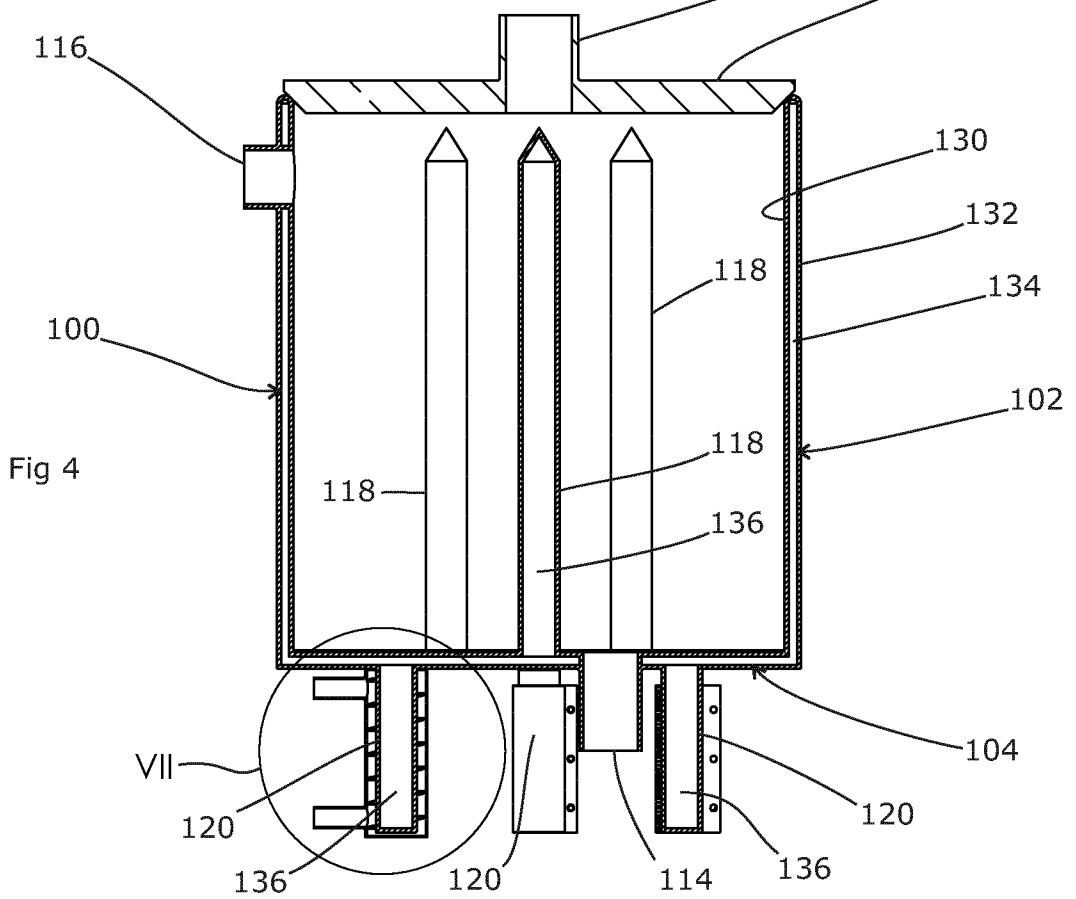
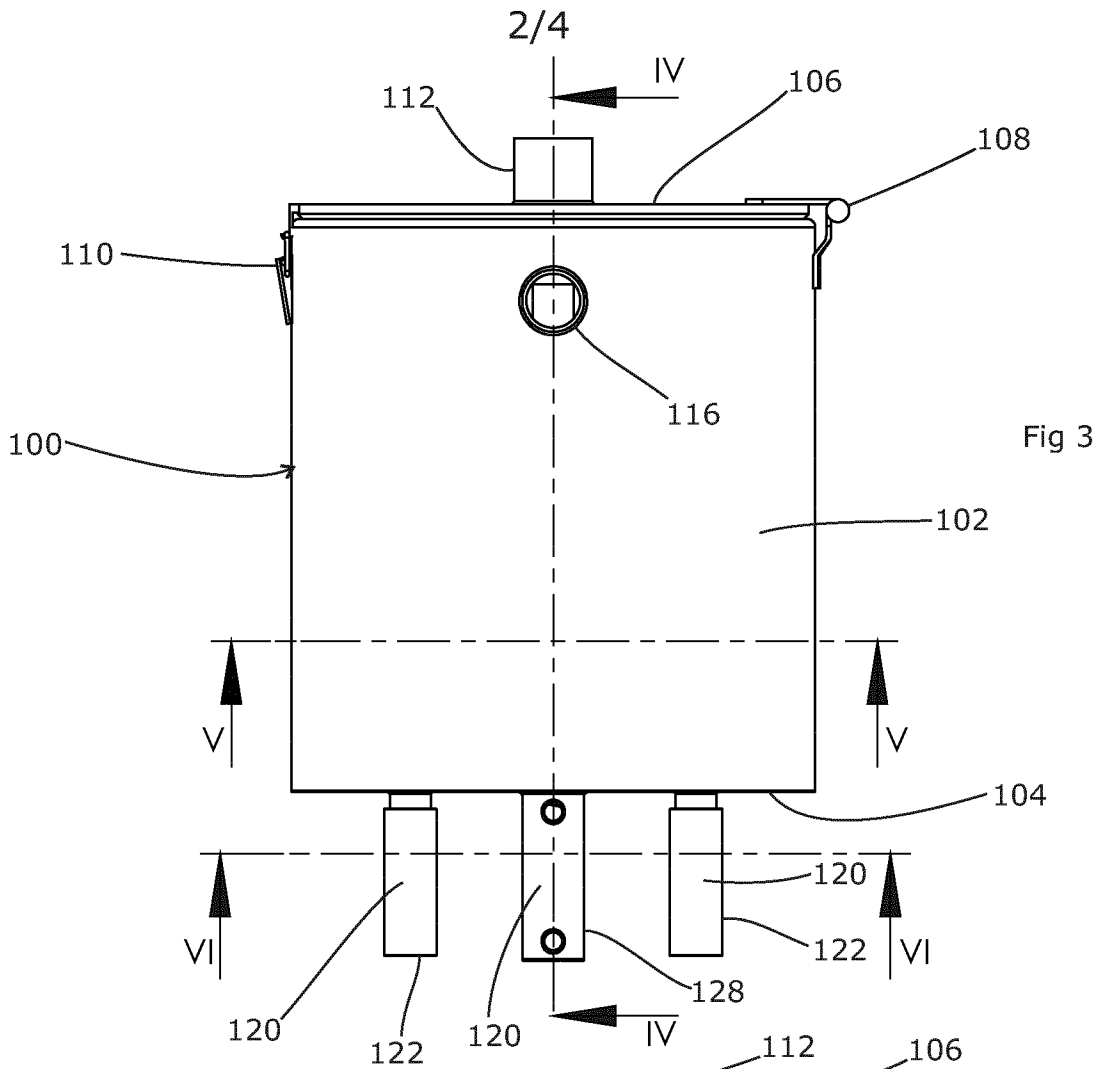
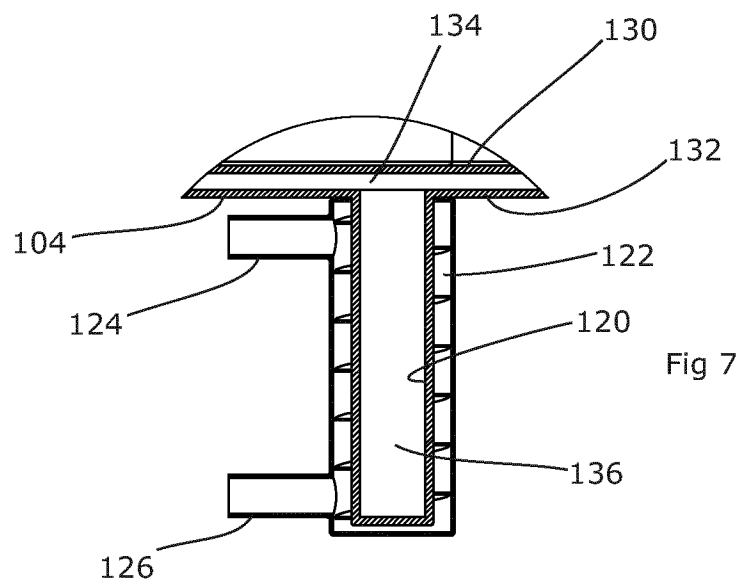
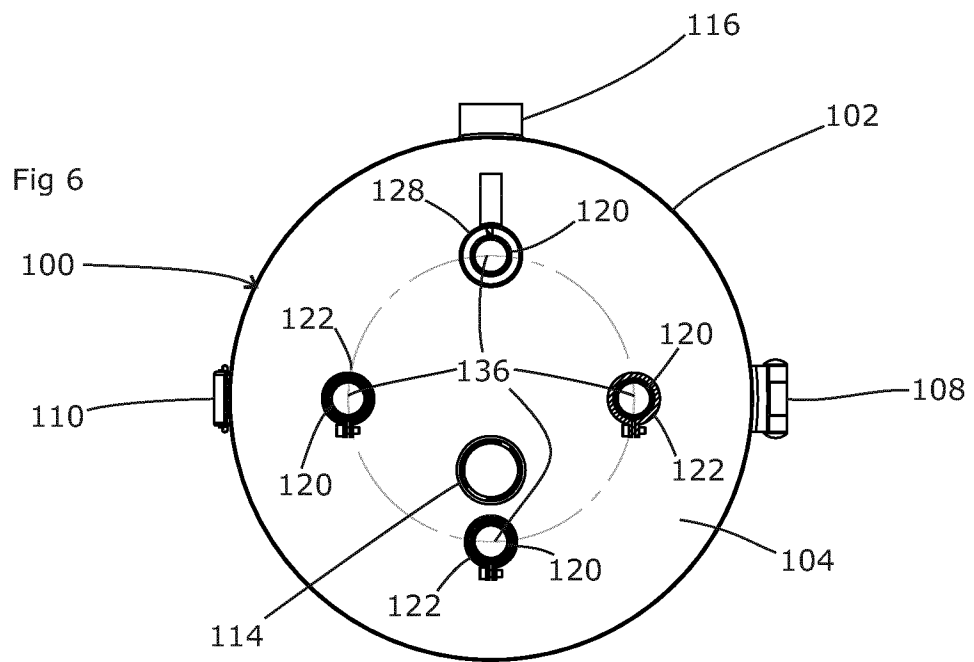
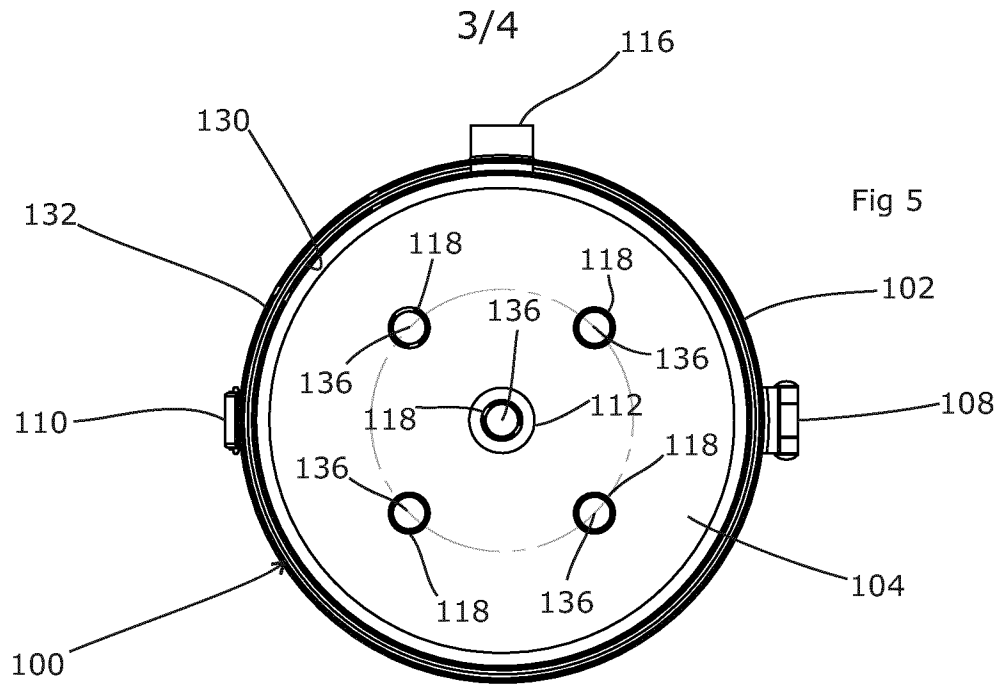

Fig 2





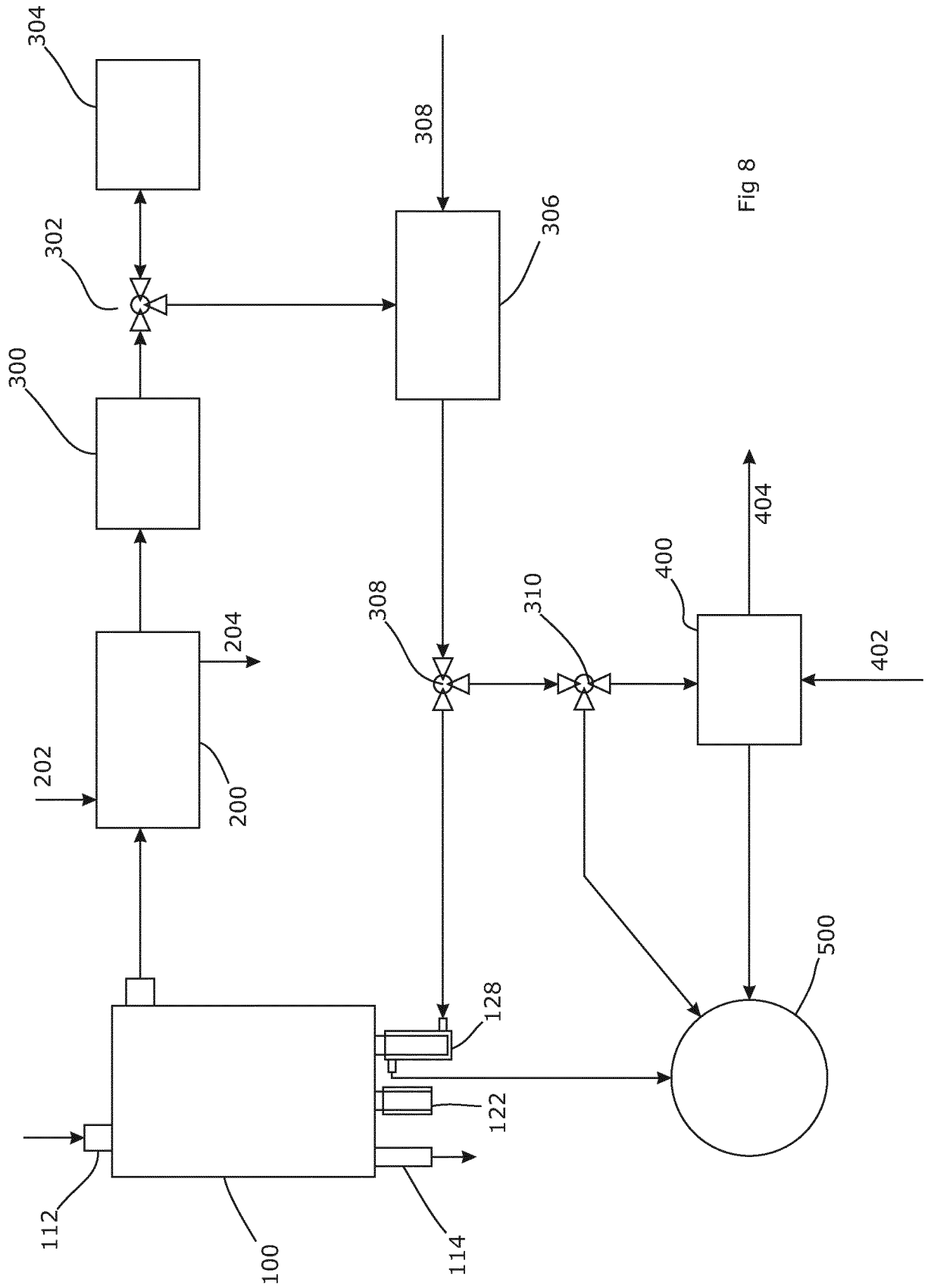

Fig 8

INTERNATIONAL SEARCH REPORT

International application No PCT/EP2015/050369

A. CLASSIFICATION OF SUBJECT MATTER INV. B09B3/00 B09B5/00 C10J3/00 F24D7/00 F24D15/00 ADD.		
According to International Patent Classification (IPC) or to both national classification and IPC		
B. FIELDS SEARCHED		
Minimum documentation searched (classification system followed by classification symbols) B09B C10J F24D		
Documentation searched other than minimum documentation to the extent that such documents are included in the fields searched		
Electronic data base consulted during the international search (name of data base and, where practicable, search terms used) EPO-Internal		
C. DOCUMENTS CONSIDERED TO BE RELEVANT		
Category*	Citation of document, with indication, where appropriate, of the relevant passages	Relevant to claim No.
X	US 2008/149471 A1 (WOLFE RICHARD A [US]) 26 June 2008 (2008-06-26)	1
Y	claims 1,3	2-10
A	-----	11-22
Y	WO 03/012007 A1 (ECOLOGICAL POWER INTERNAT HOLD [GB]; DYE KENNETH [GB]) 13 February 2003 (2003-02-13)	2-10
A	claim 1	11-22
Y	US 2007/099039 A1 (GALLOWAY TERRY R [US]) 3 May 2007 (2007-05-03)	2-10
A	abstract	11-22
Y	RU 2 258 870 C2 (KOKAREV V A [RU]) 20 August 2005 (2005-08-20)	2-10
A	abstract	12-22

<input type="checkbox"/> Further documents are listed in the continuation of Box C. <input checked="" type="checkbox"/> See patent family annex.		
* Special categories of cited documents :		
"A" document defining the general state of the art which is not considered to be of particular relevance	"T" later document published after the international filing date or priority date and not in conflict with the application but cited to understand the principle or theory underlying the invention	
"E" earlier application or patent but published on or after the international filing date	"X" document of particular relevance; the claimed invention cannot be considered novel or cannot be considered to involve an inventive step when the document is taken alone	
"L" document which may throw doubts on priority claim(s) or which is cited to establish the publication date of another citation or other special reason (as specified)	"Y" document of particular relevance; the claimed invention cannot be considered to involve an inventive step when the document is combined with one or more other such documents, such combination being obvious to a person skilled in the art	
"O" document referring to an oral disclosure, use, exhibition or other means	"&" document member of the same patent family	
"P" document published prior to the international filing date but later than the priority date claimed		
Date of the actual completion of the international search	Date of mailing of the international search report	
26 February 2015	11/03/2015	
Name and mailing address of the ISA/ European Patent Office, P.B. 5818 Patentlaan 2 NL - 2280 HV Rijswijk Tel. (+31-70) 340-2040, Fax: (+31-70) 340-3016	Authorized officer Devillers, Erick	

INTERNATIONAL SEARCH REPORT

Information on patent family members

International application No PCT/EP2015/050369

Patent document cited in search report	Publication date	Patent family member(s)	Publication date
US 2008149471 A1	26-06-2008	AU 2007340053 A1 BR PI0720677 A2 CA 2673978 A1 EP 2118241 A1 EP 2135922 A2 US 2008149471 A1 WO 2008082967 A1	10-07-2008 18-03-2014 10-07-2008 18-11-2009 23-12-2009 26-06-2008 10-07-2008

WO 03012007 A1	13-02-2003	NONE	

US 2007099039 A1	03-05-2007	US 2007099039 A1 WO 2008057467 A2	03-05-2007 15-05-2008

RU 2258870 C2	20-08-2005		