



US 2004015999A1

(19) **United States**

(12) **Patent Application Publication**
Dematteis

(10) **Pub. No.: US 2004/0159999 A1**

(43) **Pub. Date: Aug. 19, 2004**

(54) **CONVEYING ROLLER FOR A PAPER WEB, MACHINES EQUIPPED THEREWITH AND METHODS OF USE**

(57) **ABSTRACT**

(75) Inventor: **Alessandro Dematteis, Lucca (IT)**

Correspondence Address:
SIMPSON & SIMPSON, PLLC
5555 MAIN STREET
WILLIAMSVILLE, NY 14221-5406 (US)

(73) Assignee: **MTC - Macchine Trasformazione Carta S.r.l., Lucca (IT)**

(21) Appl. No.: **10/779,940**

(22) Filed: **Feb. 17, 2004**

(30) **Foreign Application Priority Data**

Feb. 18, 2003 (EP)..... 03425091.0

Publication Classification

(51) **Int. Cl.⁷ B65H 5/06**

(52) **U.S. Cl. 271/264**

The roller (1) is used for conveying a web or sheet of paper (20) in paper converting machines, for example, a rewinding, a winding, an interfolding machine. It comprises a first outer cylindrical tubular body (2) equipped with a plurality of radial holes (3), arranged according to substantially longitudinal rows, capable of rotating with respect to a second inner fixed body (4) co-axial to it and connected to a suction system. The second body (4) has tubular cylindrical geometry like the first body (2) and has a plurality of apertures (5) and two radial boards (7) arranged at opposite sides with respect to the apertures (5). The inner surface of the first cylindrical tubular body (2), together with the radial boards (7) and to the external surface of the second tubular body (4), define a suction chamber (6) that brings selectively in communication selected rows of holes (3) of the first cylindrical tubular body (2) with the apertures (5) of the second tubular body (4) and then with the suction system of the machine during the relative rotation of the two bodies. Therefore, a web or sheet of paper (20) adheres to the external surface of the first body (2) only in the portion P₁P₂ of surface set between the rows of holes (3') that communicates with the suction chamber (FIG. 4).

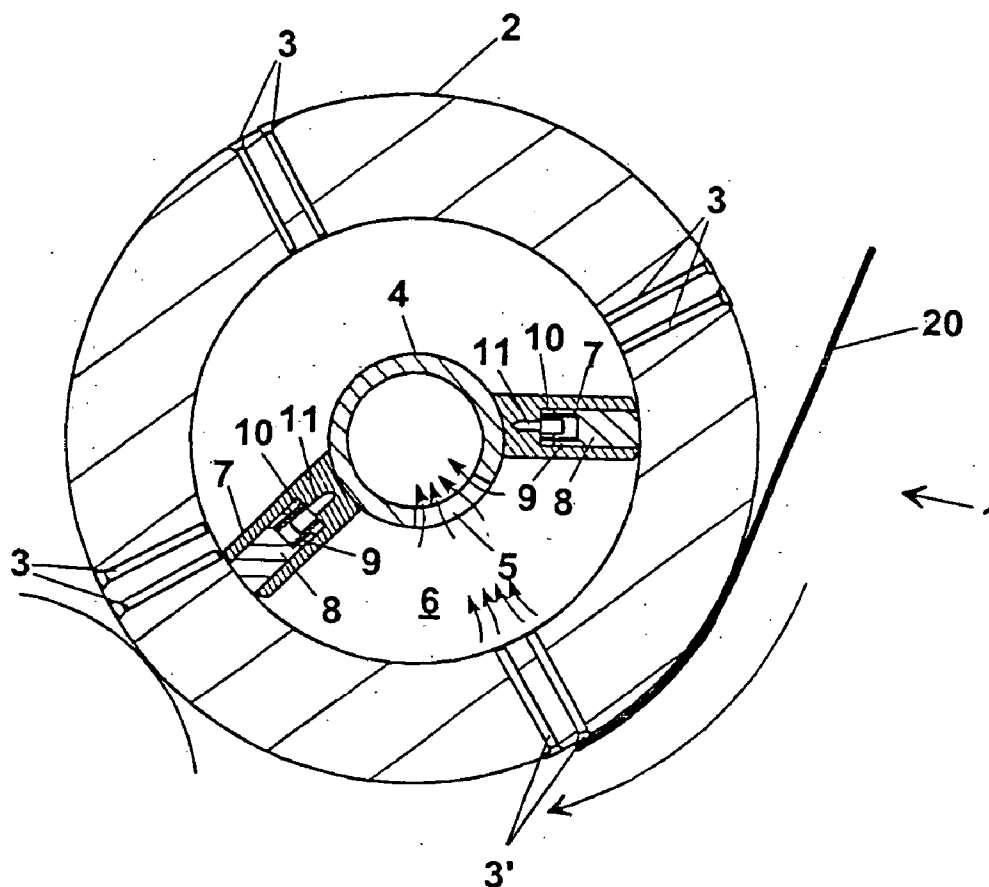

Fig. 1
(prior art)

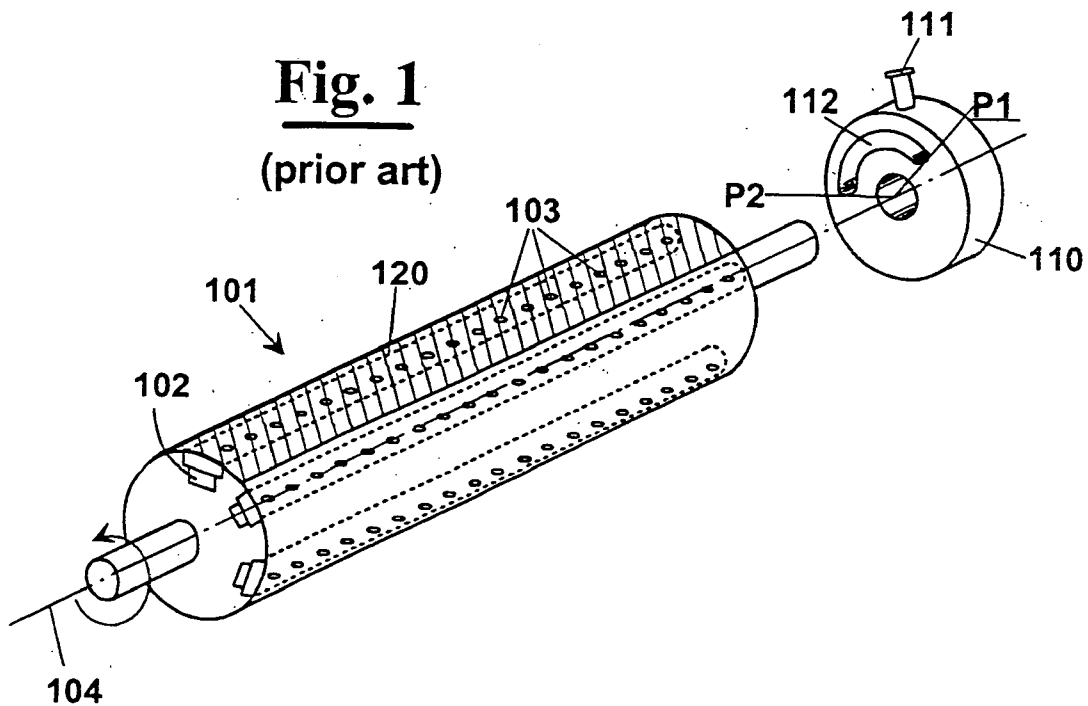

Fig. 2
(prior art)

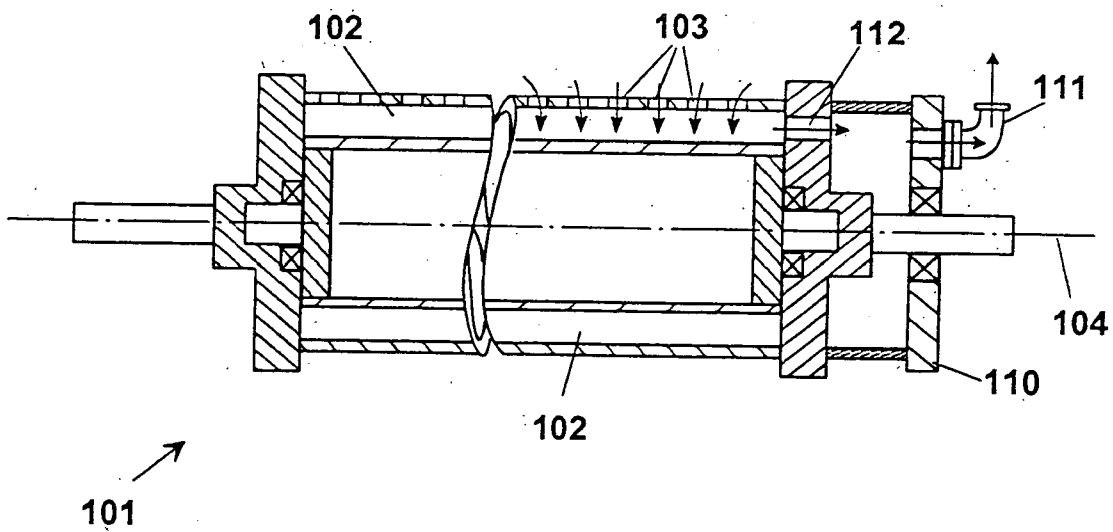

Fig. 3

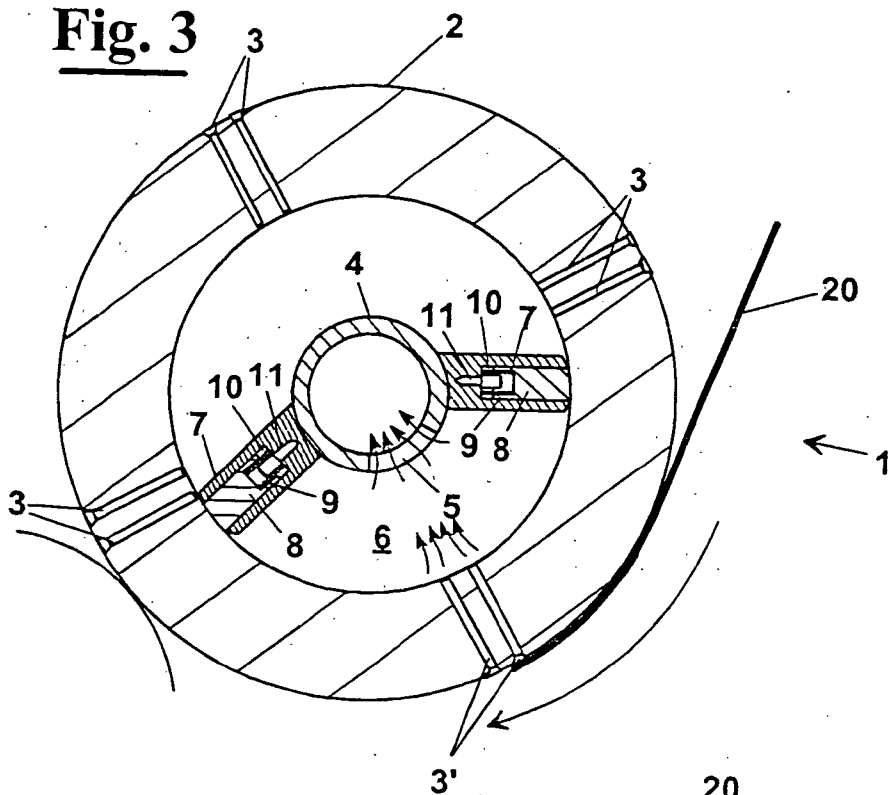
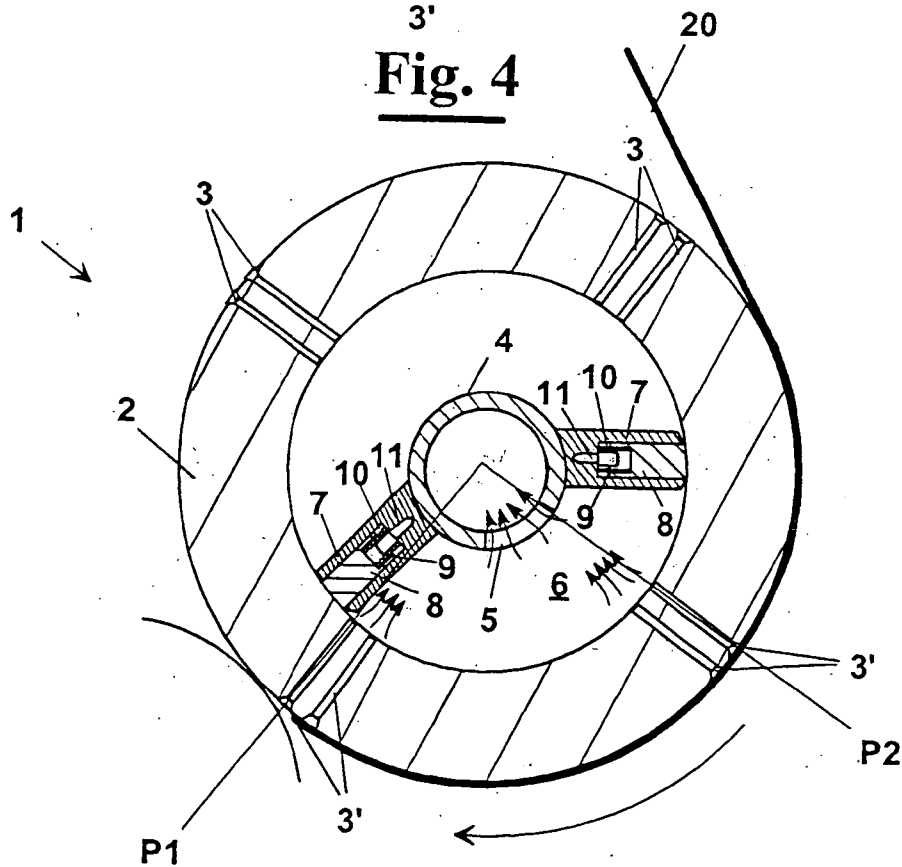
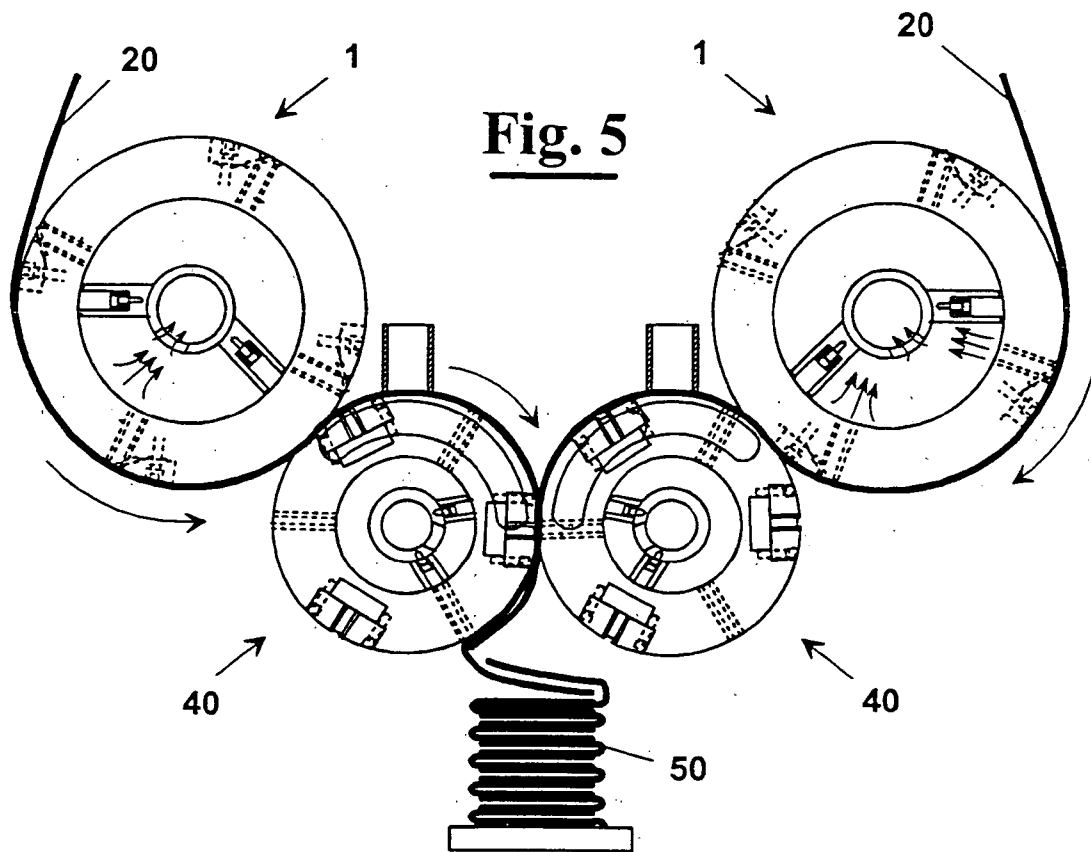

Fig. 4





**CONVEYING ROLLER FOR A PAPER WEB,
MACHINES EQUIPPED THEREWITH AND
METHODS OF USE**

FIELD OF THE INVENTION

[0001] The present invention relates to the field of machines for converting paper and similar products, and in particular it relates to a paper conveying roller for machines working in this field such as in particular winding, rewinding, interfolding machines.

[0002] In particular, the invention relates to a paper conveying roller having circumferentially a plurality of holes which, connected to a vacuum system, allow the sheet or web of paper to adhere on their surface.

DESCRIPTION OF THE PRIOR ART

[0003] As known, many machines used in the paper converting field, for example rewinding and interfolding machines, are equipped on the surface of their rollers with systems for capturing the web or the sheet of processed paper, in certain operative phases, in order to cause the paper to follow a predetermined path.

[0004] In particular, such systems are used to provide the main operations of cutting the paper, of transferring it quickly from a roller to another, of final folding the paper same. To this object, the machines are normally equipped either with mechanical clamps or with pneumatic suction means.

[0005] In the latter case, the air suction systems, owing to a certain vacuum grade created within the rollers, cause the processed paper to adhere on the roller surface by means of rows of suction holes.

[0006] In more detail, as shown diagrammatically in **FIGS. 1 and 2**, in a paper conveying roller **101**, of known art, the vacuum is transmitted through a plurality of longitudinal channels **102** into roller **101**, causing the paper **120** to adhere selectively to the roller surface same by means of a plurality of holes **103**. Normally, holes **103** are arranged according to longitudinal rows with respect to the axis **104** of the cylinder (transversal with respect to the paper) since the vacuum is made selectively by distributor means. This causes a division of the roller surface into paper suction fields, i.e. where the rows of holes are enabled for suction, and into fields where the processed paper is instead freed from the roller for being for example transferred onto another roller or folded, i.e. the respective rows of holes are not enabled for suction.

[0007] In particular, the paper conveying roller is normally coupled, at an end thereof, to a bell-shaped vacuum distributor element **110** to it co-axial but whose rotation is impeded by means of suspension on ball bearings. The vacuum distributor **110** is equipped with an inlet **111** connected to the suction system of the machine and communicating with a curved opening **112** determined on the distributor same. More in detail, the curved opening **112** extends for a certain angle and, during the rotation of the roller about its own axis, selectively communicates with longitudinal channels **102** and then with the respective rows of holes **103**. This way, a portion of roller surface (hatched area in **FIG. 1**) is obtained in which the sheet or the web of paper is captured by suction and adheres on the roller surface.

[0008] With this system, channels **102** are at atmospheric pressure except from when they are in communication with the vacuum distributor. This causes, however, the row of holes **103**, which is enabled to suction by alignment with curved opening **112**, to start the suction of the sheet on the roller surface **101** only after that the air present in the respective longitudinal channel **102** has been removed. Therefore, there is a delay between the beginning of the suction in channel **102** and the moment where the portion of roller surface located at holes row **103** can actually start the suction of the paper, owing to the vacuum inertia for the presence of air channel **102** and the propagation time of the vacuum for all the row of holes length. Furthermore, as soon as channel **102** is not more enabled for suction, even if there is a delay of the vacuum to disappear, then, in any case, the vacuum is lost and the channel returns to the atmospheric pressure.

[0009] A not efficient suction by the holes, on the other hand, can affect the successive operations of the machine causing paper jamming and stop of production.

[0010] In any case, the maximum air flow rate is limited.

[0011] In order to limit this drawback it is therefore necessary:

[0012] to limit the length of the roller and then the volume of the chambers in it; this causes a subsequent limitation in the maximum width of the paper that can be processed and then reduces productivity of the machines that have such rollers;

[0013] starting/stopping the suction of the air channel with a vacuum advance, so that the suction in all the holes starts/stops at a predetermined moment; with a vacuum advance, it is necessary to change the vacuum timing as varies the speed of operation of the machine;

[0014] working with a high vacuum grade for reducing the time necessary for a row of suction holes to be fully operative.

[0015] As described in U.S. Pat. No. 4,207,998 paper dragging rollers also exist formed by a fixed cylinder that form a longitudinal chamber, about which a concentric roller rotates formed by an inner stiff tubular shell having a plurality of holes, and an outer resilient tubular shell, having a plurality of deformable holes. When contacting the paper the deformable holes are open and bring into communication the paper with the holes of the inner shell and the suction chamber, preventing the roller from sliding with respect to the paper. The sealing ability of the holes, however is limited to the contact with a web of paper and with a certain pressure, whereby this type of roller is unsuitable for applications with sheets of paper. Furthermore, it is suitable only for narrow fields of suction.

SUMMARY OF THE INVENTION

[0016] It is an object of the present invention to provide a roller equipped with suction points for conveying a web or sheet of paper in paper converting machines, such as in particular rewinding, winding, interfolding machines, which allows to provide a high production rate even with a low vacuum grade and then not much expensive with respect to the prior art.

[0017] It is another object of the present invention to provide such a paper conveying roller for increasing productivity and flexibility of the machine on which it is mounted, in order to work webs or sheets of paper of different type and wide enough without affecting the efficiency of the process.

[0018] It is a particular object of the present invention to provide a method for conveying the paper that uses this roller.

[0019] These and other objects are achieved by the roller for conveying a web or sheet of paper in paper converting machines, such as rewinding, winding, interfolding machines, comprising a first cylindrical tubular body, equipped with a plurality of radial holes arranged according to substantially longitudinal rows, capable of rotating with respect to a second inner fixed co-axial body. The roller provides inside at least one chamber connected to a suction system, defined between the first and the second body by means of sliding sealing elements, suitable for being brought selectively in communication with at least one of said row of holes during the relative rotation of the bodies. This way, maintaining a fixed vacuum grade in the chamber, the holes that communicate with it are immediately available as elements for capturing the paper on the external roller surface.

[0020] In other words, a web or sheet of paper adheres to the external surface of the first body only in the portion of surface set between rows of holes that communicates with the suction chamber. The fact that a determined vacuum grade is steadily maintained allows to enable directly for suction the holes located in the portion of surface overlapping the suction chamber.

[0021] Therefore, it is possible to provide rollers of much more length and then of increasing the flexibility and productivity of the machines that use them.

[0022] Advantageously, also the second body is tubular cylindrical and the sliding sealing capability is obtained with two radial boards, between which at least one opening is present, which extends between the first and the second tubular body for all the length of the roller in order to define the suction chamber.

[0023] Preferably, to increase the outlet speed of the air through the suction chamber, a plurality is provided of apertures arranged longitudinally along the second cylindrical tubular body and within the portion thereof defined by the radial boards.

[0024] In particular, to assure a high sealing capability, the ends which in the suction chamber contact the inner surface of the first body can provide plastic inserts, for example of polymeric resin, which slide on the smooth inner surface of the first tubular body.

[0025] Preferably, the sealing capability of the suction chamber is achieved forcing elastically the radial boards against the inner surface of the first cylindrical tubular body. This way, the necessary side sealing conditions of the suction chamber are guaranteed without that the radial boards effect a high resistance against the relative rotation of the two cylindrical tubular bodies.

[0026] In a preferred embodiment each radial board can comprise a fixed portion, forming a guide arranged longi-

tudinally with respect to the conveying roller, within which a bar can slide radially forced elastically against the inner surface of the first cylindrical tubular body.

[0027] According to a particular aspect of the invention a paper converting machine, such as a rewinding machine, a winder or an interfolding machine, comprises at least one paper conveying roller as above described.

[0028] According to another aspect of the invention a method for moving a sheet or a web of paper in paper converting machines, such as rewinding machines, winders, interfolding machines, uses a paper conveying roller comprising a first cylindrical tubular body equipped with a plurality of radial holes arranged according to substantially longitudinal rows. The method has the feature that the holes are selectively enabled for suction or for not suction by the relative rotation between the first cylindrical tubular body and a second inner fixed co-axial body connected to a suction system through at least one opening. The relative rotation between the two bodies brings selectively in communication a suction chamber, defined between the first and the second body, with at least one of said row of holes, the chamber being defined by means of sliding sealing elements arranged between the first and the second body.

[0029] Preferably, the sealing capability of the suction chamber is achieved forcing elastically the sliding sealing elements, which belong to the second fixed co-axial body, against the inner surface of the first cylindrical tubular body.

BRIEF DESCRIPTION OF THE DRAWINGS

[0030] In the drawings, **FIGS. 1 and 2** already commented in the introductory part show the following:

[0031] **FIG. 1** is a perspective view of a paper conveying roller for paper converting machines and of the vacuum distributor to it associated, as known in the art;

[0032] **FIG. 2** shows a longitudinal cross section of a conveying roller according to the prior art coupled to a vacuum distributor.

[0033] Further characteristics and the advantages of the roller according to the present invention, equipped with suction points for conveying a web or sheet of paper in paper converting machines, will be made clearer with the following description of an embodiment thereof exemplifying but not limitative, with reference to the attached drawings wherein:

[0034] **FIGS. 3 and 4** show a cross sectional view of a paper conveying roller for paper converting machines, according to the present invention, in two relative different positions between the first and the second cylindrical tubular body;

[0035] **FIG. 5** shows a cross sectional view of a interfolding machine that has conveying rollers according to the invention.

DESCRIPTION OF A PREFERRED EMBODIMENT

[0036] In **FIGS. 3 and 4** a cross sectional view is shown of a roller **1** used for conveying a web or sheet of paper **20** for paper converting machines, for example, a rewinding machine, a winding machine, an interfolding machine. It

comprises a first outer cylindrical tubular body **2**, equipped with a plurality of radial holes **3** arranged according to substantially longitudinal rows, capable of rotating with respect to a second inner fixed body **4**, co-axial to the former and connected to a suction system not shown. The second body **4**, which as shown in the embodiments of **FIGS. 3 and 4** has tubular cylindrical geometry like first body **2**, has a plurality of apertures **5** and two radial boards **7** at opposite sides with respect to apertures **5**.

[0037] The inner surface of first cylindrical tubular body **2**, radial boards **7** and the external surface of second tubular body **4** define a suction chamber **6** that, during the relative rotation of the two bodies, brings selectively in communication some rows of holes **3** of first cylindrical tubular body **2** with the apertures **5** of second tubular body **4** and then with the suction system of the machine. Therefore, a web or sheet of paper **20** adheres to the external surface of first body **2** only in the portion P_1P_2 of the surface set between the rows of holes **3'** that communicate with the suction chamber (**FIG. 4**).

[0038] The apertures **5** made on the surface of second tubular body **4** are arranged longitudinally and are enough to allow a quick outlet of the air present in holes **3'** that in turn overlap to the suction chamber **6**. This is possible also because chamber **6** is fixedly kept at a determined vacuum grade.

[0039] In particular, radial boards **7**, between which the apertures **5** extend, are arranged radially for all the length of second cylindrical tubular body **4** and are have high sealing capability of the suction chamber from the remaining space comprised between bodies **2** and **4**. This result is obtained with radial boards having a fixed portion **10**, integral to second inner tubular body **4** and forming a longitudinal channel, and a movable portion **7** that engages with fixed portion **10** and pushes elastically against the inner surface of first tubular body **2** urged by springs **9**. Springs **9** can be located, as in the case of **FIGS. 3 and 4**, about pins **11** which are constrained in a housing within fixed portion **10**.

[0040] This way, it is possible to define with high precision the portion of the roller surface **1** enabled for the suction of the paper and to make easier possible cutting operations, which can be made between two adjacent rows of holes **3**.

[0041] This is for example effected in case of an inter-folding unit shown diagrammatically in **FIG. 5**. In particular, conveying rollers **1** are provided as above described that work in cooperation with folding rollers **40**. The unit works for example in the way described in EP0982255 or in EP0982256 in the name of the same applicant. Differently by rollers **1**, rollers **40** have six couples of rows, wherein three couples of rows of holes spaced 120° capture the end of a sheet, and other three couples of rows of holes spaced 120° , shifted 60° with respect to the former, capture through the central portions of a sheet, the end of a second overlapped sheet and ready for being interfolded. Therefore, the first three couples of holes must be enabled for suction between two consecutive cuts, for a sector between the point of contact of rollers **1** with rollers **40** up to the contact between the two opposite rollers **1**, whereas the other three couples of holes must be enabled for suction between the contact between the two rollers **40** and the point where the fold is made.

[0042] Therefore, rollers **40** are shown in **FIG. 5** having a "mixed" structure as a combination of a roller of prior art and a roller **1** according to the invention. More in detail:

[0043] the sheet is captured by roller **1** up to the point of contact between two rollers **40** by means of a traditional suction system, with suction channel and bell-shaped vacuum distributor; in fact, for capturing and holding the sheet a light vacuum grade and a not high angular precision are enough and this system is sufficient;

[0044] the passage of a sheet from an interfolding roller **40** to the other is made with a system according to the invention, since higher angular precision and higher vacuum in suction are required.

[0045] Obviously, a roller can be made that enables to suction three couples of rows of holes all with a system according to the invention. For example, the inner second body may have three radial boards, forming three chambers, one not enabled to suction and two enabled to suction with a different vacuum grade.

[0046] The present invention is applicable at a desired interfolding, rewinding or winding machine which uses a roller according to the invention.

[0047] The foregoing description of a specific embodiment will so fully reveal the invention according to the conceptual point of view, so that others, by applying current knowledge, will be able to modify and/or adapt for various applications such an embodiment without further research and without parting from the invention, and it is therefore to be understood that such adaptations and modifications will have to be considered as equivalent to the specific embodiment. The means and the materials to realise the different functions described herein could have a different nature without, for this reason, departing from the field of the invention. It is to be understood that the phraseology or terminology employed herein is for the purpose of description and not of limitation.

1. Roller for conveying a web or sheet of paper in machines for converting paper and similar products, such as in particular interfolding, rewinding or winding machines, comprising a first cylindrical tubular body equipped with a plurality of radial holes arranged according to substantially longitudinal rows characterised in that:

said tubular body is capable of rotating with respect to a second inner fixed co-axial body,

at least one suction chamber is provided connected to a suction system defined between said first and said second body by means of sliding sealing elements, said chamber being suitable for being brought selectively in communication with at least one row of said holes during the relative rotation of said bodies.

2. Conveying roller, according to claim 1, where the sealing capability of the suction chamber is achieved forcing elastically said sliding sealing elements against the inner surface of said first cylindrical tubular body.

3. Conveying roller, according to claim 1, wherein said second body is tubular cylindrical and is associated to two radial boards to it external that radially extend between said first and said second body for all the length of said roller in order to define said suction chamber, between said radial

boards at least one opening being provided that brings in communication said chamber with an inner space within said second tubular body that in turn is connected to said suction system.

4. Conveying roller, according to claim 3, wherein a plurality is provided of apertures arranged longitudinally along said second cylindrical tubular body and within the portion thereof defined by said radial boards in said chamber.

5. Conveying roller, according to claim 3, wherein the ends of said radial boards provide sealing plastic inserts to contact the inner surface of said first body.

6. Conveying roller, according to claim 3, wherein the sealing capability of the suction chamber is achieved forcing elastically said radial boards against the inner surface of said first cylindrical tubular body.

7. Conveying roller, according to claim 3, wherein each radial board comprises a fixed portion, forming a guide arranged longitudinally with respect to the conveying roller, within which a bar can slide radially forced elastically against the inner surface of the first cylindrical tubular body forming said of sliding sealing element.

8. Paper converting machines, such as a rewinding, a winding or an interfolding machine, characterised in that it

comprises at least one paper conveying roller according to the previous claims.

9. Method for moving a sheet or a web of paper along paper converting machines, such as rewinding, winding, interfolding machines, by means of a paper conveying roller comprising a first cylindrical tubular body equipped with a plurality of radial holes arranged according to substantially longitudinal rows, characterised in that said holes are selectively enabled for suction and for not suction by the relative rotation between said first cylindrical tubular body and a second inner fixed co-axial body connected to a suction system through at least one opening, said relative rotation bringing selectively in communication a suction chamber defined between said first and said second body with at least one row of said holes, said chamber being defined by sliding sealing elements arranged between said first and said second body.

10. Method according to claim 9 where the sealing capability of the suction chamber is achieved forcing elastically said sliding sealing elements, which belong to said second fixed co-axial body, against the inner surface of said first cylindrical tubular body.

* * * * *