

(No Model.)

G. NAUMAN.
MACHINE FOR FORMING RIDGE BARS.

No. 421,961.

Patented Feb. 25, 1890.

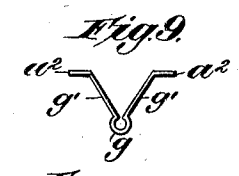
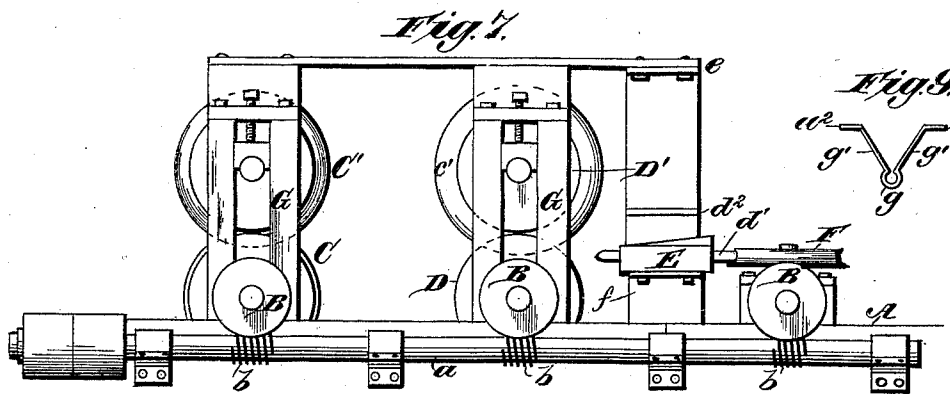
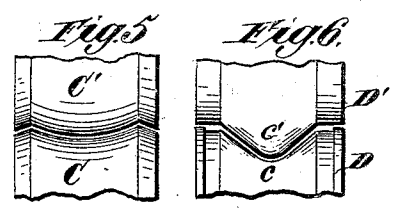
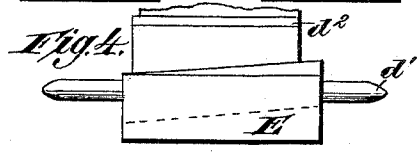
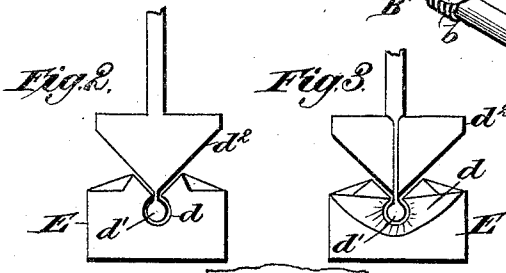
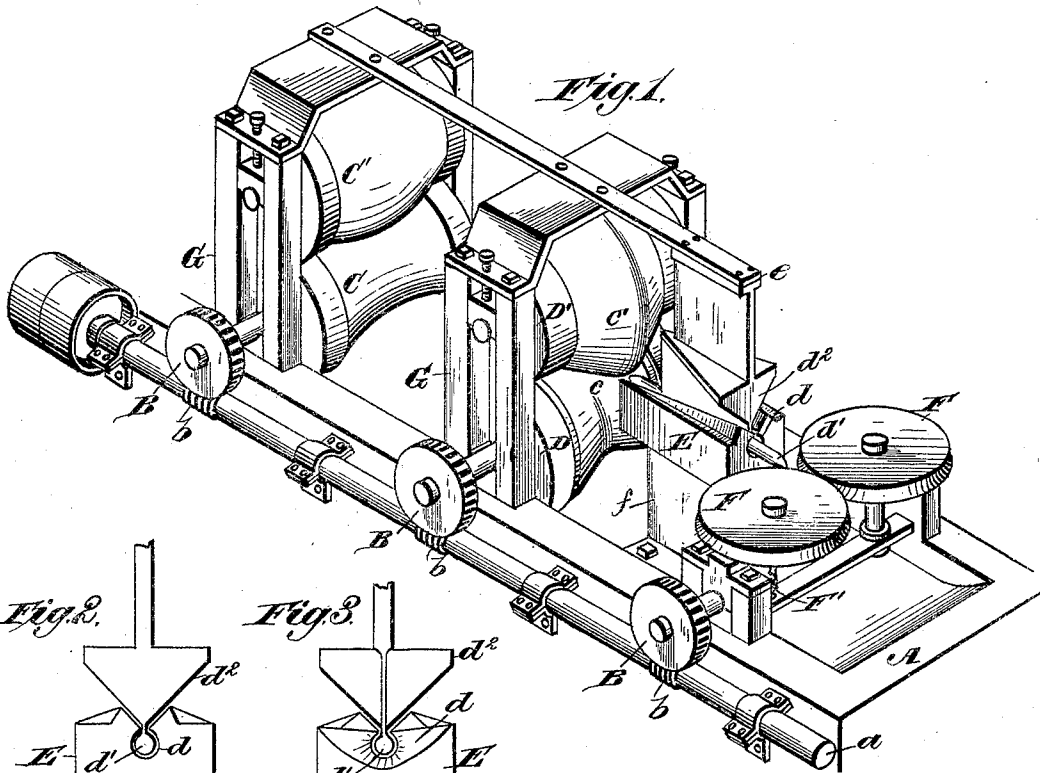

Witnesses:
Robert G. Smith
J. Grant Meyer

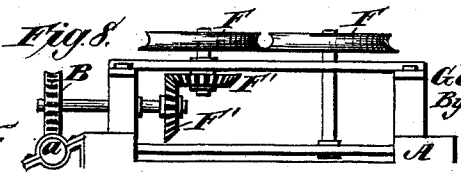

Inventor:
George Nauman
By *T. Board + W. W. R.*
Attys.

UNITED STATES PATENT OFFICE.

GEORGE NAUMAN, OF CANTON, OHIO.

MACHINE FOR FORMING RIDGE-BARS.

SPECIFICATION forming part of Letters Patent No. 421,961, dated February 25, 1890.

Application filed May 1, 1889. Serial No. 309,261. (No model.)

To all whom it may concern:

Be it known that I, GEORGE NAUMAN, a citizen of the United States, residing at Canton, in the county of Stark and State of Ohio, have invented certain new and useful improvements in Machines for Forming Ridge-Bars; and I do hereby declare that the following is a full, clear, and exact description of the same, reference being had to the annexed drawings, making a part of this specification, and to the letters of reference marked thereon, in which—

Figure 1 is an isometrical view showing the different parts properly located. Fig. 2 is a view of the rear end of the sheet-forming device. Fig. 3 is a view of the front end of the sheet-forming device. Fig. 4 is a side elevation of the sheet-forming device. Figs. 5 and 6 are side elevations of the different rolls. Fig. 7 is a side view showing the machine complete. Fig. 8 is a view of the delivery-rolls, showing their gearing. Fig. 9 is an end view of a ridge-bar properly formed.

The present invention has relation to machines for forming ridge-bars; and it consists in the different parts and combinations of parts hereinafter described, and particularly pointed out in the claims.

Similar letters of reference indicate corresponding parts in all the figures of the drawings.

In the accompanying drawings, A represents the base-frame, which may be substantially of the form shown in Fig. 1. To one side of the base-frame A is journaled the shaft *a*, which shaft is provided with the screws *b*, which are for the purpose of communicating rotary motion to the different rolls by means of the screw-wheels B. The rolls C and C' are calculated and designed to bend or curve a sheet of metal into the form shown in Fig. 5, leaving the straight flanges or portions *a*². The rolls D and D' are provided with the V-shaped flange and groove *c* *c*', which are for the purpose of forming a sheet of metal into a V shape, as illustrated in Fig. 6, at which time it enters the mouth of the forming-bar E. The forming bar or block E is provided with the tapered opening *d*, which is substantially of the form shown in Figs. 1, 2, and 3.

Within the bar or block E is located the bar or guide *d*', to which bar or guide *d*' is attached the flaring block *d*². The bar or guide *d*' and the flaring block *d*² are securely held in proper position by means of the arm *e* or its equivalent. The block E is securely held in proper position by means of the post or standard *f*, which is attached to the frame A in any well-known manner. The delivery end of the tapered opening *d* is round, as illustrated in Fig. 2, and forms the bead *g*. It will be seen that as the sheet of metal is forced or pushed through the opening *d* and past the guide *d*' and block *d*² the bead *g* and the flanges *g*' will be formed. It will also be seen that the guide *d*' will prevent the sheet from buckling.

For the purpose of causing the sheet to be conveyed after it has passed through the machine proper, the grooved rolls F are provided, and are located as illustrated in the drawings. Rotary motion is conveyed to the roller F by means of the gear-wheels F'.

It will be understood that ridge-bars can be formed of any desired length.

For the purpose of holding the rolls C, C', D, and D' in proper position, the housings G are provided, which are attached to the base A in any well-known manner.

Having fully described my invention, what I claim as new, and desire to secure by Letters Patent, is—

1. The combination of the frame A, the bending-rolls C, C', D, and D', the rolls C and C' located in advance of the rolls D and D' and in line with each other, the bar or block E, provided with the tapered opening *d*, the guide *d*', centered therein and carried by the flaring block *d*², and means for holding said guide *d*' and block *d*² in position opposite the delivery side of the rolls D D', substantially as and for the purpose specified.

2. The combination of the block E, provided with the flaring mouth or opening *d*, the flaring block *d*², located within the opening *d* and provided with the guide *d*', all of said parts being located between the bending-rolls D D' and the delivery-rolls F, substantially as and for the purpose specified.

3. The combination of the frame A, having journaled thereto the shaft *a*, provided with

the screws *b*, the wheels B, the bending-rolls C and C', D and D', the pair of rolls C and C' being located in advance of the rolls D and D', the block E, provided with the tapered opening *d*, the tapered block *d*², having attached thereto the guide *d*', centered in the opening *d*, and means for supporting the blocks E and *d*², the delivery-rolls F, located at the rear of the rolls D and D', and means

for rotating said delivery-rolls, substantially as and for the purpose specified.

In testimony that I claim the above I have hereunto subscribed my name in the presence of two witnesses.

GEORGE NAUMAN.

Witnesses:

JAMES STEEN,
FRED W. BOND.