



(11) **EP 1 903 201 B1**

(12) **EUROPEAN PATENT SPECIFICATION**

(45) Date of publication and mention of the grant of the patent:
12.04.2017 Bulletin 2017/15

(51) Int Cl.:
F02D 41/20^(2006.01) H01F 7/18^(2006.01)

(21) Application number: **07018287.8**

(22) Date of filing: **18.09.2007**

(54) **Valve control strategy and controller**

Strategie und Steuerung zur Ventilsteuerung

Stratégie de contrôle de soupape et contrôleur

(84) Designated Contracting States:
AT BE BG CH CY CZ DE DK EE ES FI FR GB GR HU IE IS IT LI LT LU LV MC MT NL PL PT RO SE SI SK TR

(30) Priority: **20.09.2006 EP 06254874**
10.10.2006 GB 0620050

(43) Date of publication of application:
26.03.2008 Bulletin 2008/13

(73) Proprietor: **Delphi International Operations Luxembourg S.à r.l.**
4940 Bascharage (LU)

(72) Inventors:
• **Archer, Michael A.**
Twickenham
Middlesex, TW1 1BH (GB)
• **Matheson, Paul L.**
Chiswick
London, W4 1EG (GB)

• **Fallahi, Abdolreza**
Pinner
Middlesex, HA5 4BP (GB)
• **Potter, Anthony W.**
High Wycombe
Buckinghamshire, HP13 6JG (GB)

(74) Representative: **Delphi France SAS**
Patent Department
22, avenue des Nations
CS 65059 Villepinte
95972 Roissy CDG Cedex (FR)

(56) References cited:
EP-A- 1 344 921 WO-A-2005/014992
DE-A1- 10 011 924 JP-A- 2002 039 003
US-A- 5 424 637 US-A1- 2003 010 325
US-A1- 2005 047 053

EP 1 903 201 B1

Note: Within nine months of the publication of the mention of the grant of the European patent in the European Patent Bulletin, any person may give notice to the European Patent Office of opposition to that patent, in accordance with the Implementing Regulations. Notice of opposition shall not be deemed to have been filed until the opposition fee has been paid. (Art. 99(1) European Patent Convention).

Description

Technical Field

[0001] The present invention relates to a valve control strategy and controller. More particularly, the present invention relates to a method and a device for controlling a solenoid valve, particularly for injecting fuel into an internal combustion engine.

Background to the Invention

[0002] In electronically-controlled fuel injection systems, actuator controlled valves (e.g. solenoid valves) are used to control the flow of fuel within the injector, and hence, timing, pressure and quantity of fuel injected into the engine cylinders.

[0003] For single-valve injection systems, such as Electronic Unit Injectors (EUIs) and Electronic Unit Pumps (EUPs) a single solenoid valve - known as the "Spill Valve" - is used to control the point at which fuel pressure within the injector volume begins to increase. If the valve is open, fuel will be allowed to "spill" to low pressure (the fuel tank). Alternatively, if the valve is closed, the mass of fuel within the injector will undergo pressurisation due to the advancing cam-driven plunger reducing the injector volume. Injection of fuel into the engine's cylinder occurs once the fuel pressure within the injector becomes greater than the spring pressure which holds the injector needle closed against its seat, resulting in "injector needle lift". Fuel injection will continue until the Spill Valve re-opens, spilling fuel to low pressure, resulting in the spring forcing the injector needle to return to its closed position. In this situation, the fuel pressure necessary to lift the needle at the start of injection (known as Nozzle Opening Pressure, or NOP) is related to the force within the needle spring (i.e., spring NOP).

[0004] In the case of twin-valve injection systems, a secondary solenoid valve is used to regulate the control pressure applied to the back of the injector needle and, hence, NOP can exceed the needle spring pressure (i.e., variable NOP). This solenoid valve is known as the "Needle Control Valve". It is a "three-way" valve, in that it exposes the port, the pressure of which is to be controlled, to either a high control pressure (when de-energised) or a drain pressure (when energised).

[0005] Similar actuator controlled valves are used in Common Rail fuel injection systems too.

[0006] This invention refers to the control of both single and twin valve injection systems.

[0007] Valve movement is facilitated by means of an actuator which comprises an electromagnetic stator (a series of coil windings wound around a stator core), through which a current is passed to activate an armature. A valve pin is directly attached to the armature, and subsequent movement of the armature/valve assembly is used to control flow of fuel within the injector. The valve

pin is held in the open position by a return spring, therefore any electromagnetic force induced by the solenoid coil is working against the spring to close the valve.

[0008] The control of the solenoid valve is divided into two general categories, a so called "pull-in" phase and a "hold phase".

[0009] During the pull-in phase, the armature of the solenoid-controlled valve is caused to close by the application of a first current level through the solenoid coil. During the hold phase a second, lower current level is supplied to the solenoid coil to keep the valve closed.

[0010] The driving current provided during the pull-in phase is supplied by a capacitor. The capacitor and associated circuitry provide a further voltage supply means (in addition to the battery) and are hereinafter collectively referred to as the "Boost circuit".

[0011] The driving current provided during the hold phase is supplied by applying the standard battery voltage across the solenoid coil in order to provide the second current level. A so-called "chopping circuit" controls the application of the battery voltage so that the required drive current supplied to the actuator throughout the injection is between defined upper and lower hold thresholds.

[0012] As the battery voltage decreases, the chopping circuit may constantly apply the battery voltage to the solenoid coil during the entire hold phase of injection in order to maintain the driving current to the solenoid between the desired threshold levels.

[0013] When the battery level falls too far however the chopping circuit will not be able to compensate and the driving current applied to the actuator may fall below a lower threshold thereby resulting in compromised valve performance. In such cases, a series of additional voltage pulses from the Boost circuit may be applied to the solenoid coil in order to maintain the current above a minimum current level. During such periods the battery voltage will be applied consistently while the Boost circuitry is activated to produce the additional voltage pulses (Boost voltage pulses) to maintain the current at the desired level.

[0014] The frequency of the additional Boost voltage pulses may be controlled by electronic hardware or alternatively by a software module running as part of the Boost circuitry. In existing systems, the activation of additional boost voltage pulses is determined with respect to the battery voltage as measured by the vehicle's engine control unit (ECU). In other words, once the battery voltage, as measured by the ECU, drops below a calibrated threshold value, additional boost pulses are activated.

[0015] By way of background, US 2005/047053 discloses the preamble of claim 1 and describes a system for driving one or more solenoid actuators, in which a controller is operable to selectively supply either a battery voltage, or a boosted voltage that is greater than the battery voltage, to the or each solenoid.

[0016] The solenoid coil resistance changes depend-

ing on the operating conditions of the engine. For example, when the engine is cold the solenoid coil resistance will be lower than when the engine is hot. During periods of low solenoid coil resistance, coil current levels will be higher at low voltages compared to periods of higher solenoid coil resistance. The requirement for an additional series of Boost voltage pulses will therefore reduce during such periods.

[0017] It is noted that exposing the solenoid coils to unduly high current levels, for example due to the constant application of battery voltage during periods when the Boost circuitry is switched on, may result in damage to the coil. However, as noted above the determining factor that governs whether the Boost circuitry is activated to provide additional voltage pulses is the voltage across the battery as measured by the ECU. In other words, existing systems do not take account of the operating conditions of the engine and the resistance of the solenoid coils when determining when to provide additional voltage pulses.

[0018] It should also be noted that battery voltage is often at its lowest when attempting to start the engine in very cold conditions, because, typically, the engine lubrication oil viscosity is much higher and the engine is therefore that much harder to turn over taking a greater drain on the battery. Additionally the battery may struggle to perform as well at the lower temperatures.

[0019] It is therefore an object of the present invention to provide a method and control device for activating and controlling a solenoid controlled valve that substantially overcomes or mitigates the above mentioned problems.

[0020] According to a first aspect of the present invention, there is provided a controller for controlling the operation of a valve in an engine system, the valve being in communication with a battery and a further voltage supply means and comprising an actuator, the controller comprising inputs for receiving data representing the voltage across the battery and further voltage supply means and the current through the actuator; a processor programmed to determine a control function for controlling the operation of the valve; and outputs for outputting the control function as determined by the processor to control the operation of the valve wherein the processor is arranged to determine the resistance of the actuator from the data representing the voltage across the further voltage supply means and the current through the actuator and to determine the control function for controlling the operation of the valve in dependence on the voltage across the battery and the resistance of the actuator.

[0021] The present invention provides a controller for controlling valve operation in which a number of valve system parameters, e.g. voltage across the further voltage supply means that provides the Boost voltages and also the current through the actuator (i.e. the current through the solenoid coil), are measured and then used to determine a control function for controlling the valve operation. By measuring the voltage and current values within the valve circuitry it is possible for the controller to

detect changes in the operational characteristics of the system. The processor can then determine a control function for controlling the voltages applied by the battery and further voltage supply means in accordance with the measured current and voltage values.

[0022] The control function may control the valve operation either via a software based control system or via changes to a hardware control circuit.

[0023] Conveniently, in the case of a software solution, the control function comprises a voltage pulse logic structure that relates to the voltage levels to be applied across the actuator. The voltage pulse logic structure may comprise logic structures that relate to the operation of the further voltage supply means and logic structures that relate to the operation of the battery.

[0024] In the case of a hardware implementation, the battery and further voltage supply means will be controlled by the switching of control switches (power switches) within the power circuit for the engine control. Conveniently, in this case, the control function comprises a control sequence for controlling the switching of the control switches within the engine's power circuit.

[0025] Conveniently the controller will sub-divide the operation of the valve into two phases, a so-called pull-in phase and a hold phase, and will determine the control function appropriately. During the pull-in phase a voltage pulse from the further voltage supply means is applied across the solenoid coil within the actuator in order to cause the valve to move from a first state (e.g. valve open) to a second state (e.g. valve closed). It is noted that the valve will be held open by the action of a return spring within the valve and so, in order to achieve rapid valve closure, an initial voltage pulse above the normal battery voltage is required. This "Boost voltage" (first voltage potential) is applied by the capacitor. Once the valve has been closed the valve enters the hold phase in which the battery voltage (second voltage potential) that is applied across the actuator (solenoid coil) is sufficient to hold the valve closed.

[0026] In the event of low battery voltage the controller is preferably arranged to apply at least one further pulse from the further voltage supply means across the actuator. This further pulse is preferably at a voltage potential greater than the battery voltage and more preferably at the first voltage potential.

[0027] In the event that the controller applies further pulses during the hold phase, the controller is preferably arranged to apply the second voltage potential (the battery voltage) across the actuator in between the further pulses. This has the advantage of reducing the power that is drawn from the boost capacitor.

[0028] In the case of the hardware implementation detailed above, the drive circuit may comprise a high side switch to gate the battery voltage or the further voltage supply means and a boost switch to control the further pulses. The control function may in this case be arranged to send control pulses to the boost switch and to continuously drive the high side switch until the end of the hold

phase.

[0029] Conveniently, the controller further comprises (i) a two dimensional function map that relates the voltage across the further voltage supply means and the current flowing through the actuator to the resistance of the actuator and (ii) a one dimensional map that relates the resistance of the actuator to the battery voltage at which further voltage pulses from the further voltage supply means are required, i.e. an activation voltage.

[0030] In use therefore, the controller uses the voltage across the further voltage supply means and actuator current measurements received at its inputs to determine the resistance of the actuator from the first function map. Once the resistance of the actuator has been determined the second function map can be used to derive the activation voltage that signals that further capacitor voltage pulses are required to control the valve operation. The battery voltage can then be monitored and as soon as this falls below the activation voltage one or more further pulses at the voltage of the further voltage supply means (Boost voltage pulses) can be applied to the actuator.

[0031] Conveniently, the first and second function mode maps can be populated with data derived during one or more test phases, i.e. during manufacturing or testing / calibration of the engine system.

[0032] Preferably, the controller measures the voltage across the capacitor prior to initiation of the pull-in phase, i.e. when the capacitor is fully charged. The current flowing through the solenoid coil of the actuator can conveniently be measured during the pull-in phase so that the controller may initiate extra Boost pulses as needed during the hold phase.

[0033] Minor voltage fluctuations around the activation voltage may cause rapid on/off enabling of the additional Boost pulses. To avoid this the controller preferably applies a hysteresis band about the activation voltage such that the battery voltage must rise above the activation voltage + the hysteresis band before the additional Boost pulses are discontinued.

[0034] It is noted that the current level through the coil of solenoid valves in fuel injection systems is often measured at around 60% of the interval between the start of the pull-in phase and pull-in peak current (typically 200-400 microseconds after the start of the pull-in phase) for diagnostic purposes (e.g. to determine if there are any short circuits). Conveniently, the current value measured at this time can be passed to the controller for use in determining the resistance of the solenoid coil within the actuator.

[0035] Conveniently, the control function is arranged to maintain the current through the actuator between upper and lower hold thresholds during the hold phase.

[0036] Conveniently, the actuator comprises a solenoid coil and the first and second function maps relate to the resistance through the coil of the solenoid.

[0037] Conveniently, the further voltage supply means comprises a capacitor.

[0038] The invention extends to an engine control unit

for a vehicle and a vehicle comprising a controller according to the first aspect of the present invention.

[0039] Vehicle electrical systems that use solenoids to control fuel injection equipment often experience significant drops in the normal operating voltage of the battery during certain engine conditions, e.g. during engine starting wherein the nominal battery voltage can drop briefly by up to 50% of its normal value.

[0040] Existing systems accommodate these reductions in the battery voltage by designing the coils within the solenoid to operate down to 50% of normal battery voltage. In general this means that the operating current must be twice what would be required for a coil designed to operate at nominal system voltage (It is noted that ampere turns is the factor which determines the magnetic force of the solenoid. In order to obtain the same ampere turns at half nominal voltage, the number of turns is reduced by a factor of 2 (this reduces the coil resistance by a factor of 4 since the wire CSA (cross-sectional area) doubles) and the current increases by a factor of 2. This assumes that the coil resistance limits the current according to Ohm's Law $I = V/R$).

[0041] Designing the solenoid in this way also means that the solenoid drivers, cable harness and connectors must be rated for twice the current that would otherwise be required for a coil designed to operate at normal voltage. This imposes undesirable system cost penalties for what is a very transitory condition amounting to less than 1 % of operating life.

[0042] Vehicle systems that comprise Boost circuitry as described above may exploit the systems ability to supply Boost pulses in order to allow the solenoid coils to be designed for operation at normal system voltage and to maintain the current at voltages lower than normal system voltage. By using the Boost circuitry during periods of low battery voltage, the operating current of the injector solenoid can be reduced to about half that of existing systems.

[0043] According to a second aspect of the present invention, there is therefore provided a vehicle injection system comprising a controller as described above, at least one solenoid valve, the operation of the at least one valve being controlled by the controller, a battery having a normal operating voltage of V_{BAT} and a further voltage supply means, wherein

- (i) the controller comprises a processor programmed to determine a control function for controlling the operation of the at least one solenoid valve, the control function being arranged, in a pull-in phase, to apply a pulse from the further voltage supply means at a first voltage potential across the at least one solenoid valve so that the valve is caused to move from a first state to a second state and is arranged, in a hold phase, to apply a second voltage potential or series of pulses at a second voltage potential from the battery across the at least one solenoid valve;
- (ii) during the hold phase the control function as de-

terminated by the processor is arranged to apply at least one further pulse at a voltage potential greater than the second voltage potential, and;
 (iii) each at least one solenoid valve comprises a coil of n turns, the number of turns n being determined by the normal operating voltage V_{BAT} of the battery.

[0044] Conveniently, the controller is the controller according to the first aspect of the present invention.

[0045] According to a third aspect of the present invention, there is provided a method of controlling the operation of a valve in an engine system, the valve being in communication with a battery and a further voltage supply means and comprising an actuator, the method comprising: receiving data representing the voltage across the battery and the voltage across the further voltage supply means; receiving data representing the current through the actuator; determining the resistance of the actuator from the data representing the voltage across the further voltage supply means and the current through the actuator; determining a control function for controlling the operation of the valve in dependence on the voltage across the further voltage supply means and the resistance of the actuator, and; outputting the control function to the battery and further voltage supply means.

[0046] According to another aspect there is provided a carrier medium for carrying a computer readable code for controlling a processor, computer, controller or engine control unit to carry out the method of the third aspect of the invention.

Brief Description of the Drawings

[0047] In order that the invention may be more readily understood, reference will now be made, by way of example, to the accompanying drawings in which:

Figure 1 is a schematic of the solenoid valve coil and associated control system;

Figure 2 shows control logic and current waveforms applied to the solenoid coil of the valve of Figure 1 during normal operating conditions;

Figure 3 shows control logic and current waveforms applied to the solenoid coil of the valve of Figure 1 during periods of low battery voltage;

Figure 4 shows control logic and current waveforms applied to the solenoid coil of the solenoid of Figure 1 during periods when additional boost voltage pulses are applied to the solenoid;

Figure 5 shows the control logic and current waveforms of Figure 2 in more detail;

Figure 6 shows the variation in the measured current waveform at two different engine conditions;

Figure 7 is a diagram showing how Coil Resistance is calculated from a 2-D map of Coil Current versus Capacitor Voltage;

Figure 8 is a graph depicting how Redrive Activation Voltage varies as a function of Coil Resistance;

Figure 9 is a functional diagram showing solenoid coil resistance calculation;

Figure 10 is a functional diagram showing the logic involved in determining whether additional boost voltage pulses should be activated;

Figure 11 shows a circuit schematic for a typical fuel injector drive system comprising Boost circuitry, and;

Figure 12 shows a modified circuit schematic that incorporates additional logic to enable the Boost circuitry to apply additional Boost pulses during the hold phase of the system.

Detailed Description

[0048] Turning to Figure 1, a solenoid coil, drive circuit and control system is shown in functional form. The solenoid coil 1 can be energised by passing a current there-through in order to induce motion in the valve armature (not shown).

[0049] The solenoid coil 1 is electrically connected to a battery 2 and a capacitor 3 which are operated to provide the requisite electrical current through the solenoid coil 1 to control valve motion. A suitable control means, depicted in this example as the electronic control unit (ECU) 4 of the engine system, controls the operation of the battery 2 and capacitor 3.

[0050] In use, the ECU 4 sends control signals to the Boost FET 5, High Side Drive (HSD) FET 6, and Low Side Drive (LSD) FET 7 in order to close or open the electrical circuit depicted in Figure 1. Closing of the LSD FET 7, along with the HSD FET 6 will expose the solenoid coil 1 to battery voltage 2. If in addition to these two FET switches the Boost FET 5 is closed, then the coil is exposed to the boost capacitor 3 which applies a 50V Boost voltage (compared to the normal battery voltage level of around 14V) across the solenoid coil. Charging of the boost capacitor 3 is performed by the battery 2 via the "Boost Circuit" (not shown). It is noted that the Boost Circuit additionally comprises a DC/DC converter (for charging the capacitor). The DC/DC converter should operate down to at least 50% of the normal battery voltage. So, for a nominal 12volt system operating at up to 14volts, it is capable of operating at 6volts.

[0051] Prior to the valve closing, the solenoid valve is held open by the action of a return spring (not shown) within the valve. In order to trigger valve motion against the action of the return spring, an initial "pull in" phase is initiated. This is achieved when the ECU 4 sends a series

of control signals 8a, 8b, 8c to all FET switches 5, 6, 7, indicating 'on', which results in 50V being applied across the solenoid coil 1, and subsequent current flow through the coil via electrical connection 9. In other words, during the pull in phase, the capacitor applies a Boost voltage 3 across the solenoid coil 1.

[0052] Once the valve has closed, the ECU 4 instructs the HSD FET 6, and LSD FET 7 (by sending control signals 8b and 8c) to apply a voltage (or series of voltage pulses) across the solenoid coil 1 via electrical connection 9. Therefore, once the valve has been closed, the battery 2 applies a battery voltage across the solenoid coil 1.

[0053] The ECU 4 is capable of measuring (depicted as signal 10 in Figure 1) the voltage across the capacitor 3 terminals. The ECU 4 is also capable of measuring the battery voltage (depicted as signal 11 in Figure 1) and also the current flowing through the solenoid 1 (depicted as signal 12 in Figure 1).

[0054] Turning now to Figures 2 to 4, the control logic followed by the ECU 4 and the resultant current waveforms applied through the solenoid coil 1 are now discussed.

[0055] Figure 2 shows a control logic trace 31 representing the control signals (8a and 8b) sent from the ECU 4 to the Boost FET 5 and HSD FET 6. Note that the control logic trace also represents the voltage level applied across the solenoid coil 1 resulting from operation of the FET switches. Figure 2 further shows a current waveform trace 33 that represents the current flowing through the solenoid coil 1 as a result of the voltages applied by the capacitor 3 and battery 2.

[0056] In the present example, the capacitor 3 is capable of providing a Boost voltage potential of 50V across the solenoid coil 1. The battery voltage (V_{BAT} - typically 14V) is lower than the Boost voltage.

[0057] The pull in phase of operation is initiated by the ECU 4 sending a control signal 8a and 8b to the Boost FET 5 and HSD FET 6 to apply a Boost voltage to the solenoid coil 1. The control logic 33 therefore comprises a Boost command 35.

[0058] As the Boost voltage is applied, the current through the coil 1 rises to an initial peak value 37. The Boost command lasts until the ECU detects that the coil current has reached the upper peak threshold (typically 10Amp), or, until a specified "Pull-in time" (defined in software, typically 750 microseconds) has elapsed - whichever of the two comes first. Once the Boost command/voltage stops the current through the actuator begins to fall (indicated as 39 on Figure 2). This corresponds to the end of the pull in phase and the start of the hold phase.

[0059] For the valve to operate correctly the driving current through the actuator coil 1 during the hold phase of operation should be between upper and lower hold thresholds (41 and 43 respectively). In order to maintain the driving current between the defined thresholds (41, 43) the ECU 4 applies a series of battery voltage pulses

(V_{BAT}) to the actuator by sending a series of commands (45a, 45b, 45c, 45d...45n) to the HSD FET 6. Please note, during the entire drive phase (pull-in phase and hold phase), the control signal 8c from the ECU 4 to the LSD FET 7 is 'on' in order to close the circuit.

[0060] The start of each command (45) corresponds to the driving current reaching the lower hold threshold 43. The end of each command (45) corresponds to the driving current reaching the upper hold threshold 41.

[0061] The ECU 4 continues to apply voltage pulses of V_{BAT} until injection through the valve (and, therefore, the hold phase) is due to end.

[0062] The solenoid valve will operate in accordance with the control logic shown in Figure 2 during periods when the battery is running at the standard battery voltage.

[0063] If the ECU 4 detects (via measurement signal 11) that the battery voltage is lower than the standard value then the valve 1 may be operated in accordance with the control logic depicted in Figure 3.

[0064] In Figure 3, the Boost command 35 takes place as described in relation to Figure 2. A command 47 is then sent to the HSD FET 6 to apply the battery voltage across the solenoid coil 1 as before. However, in this case the battery voltage has dropped from its nominal operating level and as a consequence the current falls below the lower threshold value 43.

[0065] As a result of the lower battery voltage, the ECU 4 keeps the battery voltage applied during the entire hold phase of injection in order to keep the driving current between the upper and lower threshold values (41, 43).

[0066] If the battery voltage drops further (i.e. below the battery voltage depicted in Figure 3) then, even with a constantly applied battery voltage, the hold phase current may drop below the lower threshold value 43.

[0067] It is noted that if the driving current drops below the lower hold threshold 43 then valve (and thus injector performance) will be severely compromised. Therefore, in order to meet the current requirements during periods of lower battery voltage the ECU 4 may apply a series of additional Boost voltage pulses from the capacitor 3 to the solenoid coil 1 in order raise the driving current during the hold phase back above the lower hold threshold 43.

[0068] This scenario is depicted in Figure 4. In Figure 4 the command logic comprises an initial Boost command 35 as in Figures 2 and 3. However, following the end of the Boost command there are now a series of further Boost pulses (49a, 49b...49n). It is noted that in between the further Boost pulses (49a, 49b...49n) the command logic applies the battery voltage to the actuator (command 51).

[0069] The frequency of the further Boost pulses (49a, 49b...49n) is controlled by the ECU 4. In current systems, activation of the control scenario of Figure 4 (hereinafter referred to as "Boost re-drive") is initiated by the ECU 4 detecting, via measurement signal 11, that the voltage across the battery 2 has dropped below a threshold level.

[0070] When the Boost re-drive strategy is initiated the

battery voltage is applied constantly during the hold phase (as noted above in relation to Figure 4), while the capacitor 3 is used to maintain the driving current above the minimum current requirement (lower threshold 43). It is noted that the capacitor will only partially discharge when providing voltage pulses during the Boost re-drive strategy).

[0071] It is noted however that during periods of low solenoid coil 1 resistance (for example when the engine is cold), the coil current levels will be higher at low voltages than when the engine is warm. During low coil resistance periods therefore the need for the Boost Re-drive strategy is reduced. It is noted that exposing the actuator coils to unduly high current levels (due to the constant application of the battery voltage during the Boost Re-drive strategy) may result in damage to the solenoid coils 1.

[0072] The present invention provides a method of determining (and an associated device for determining) the activation threshold of the Boost re-drive strategy as a function of the resistance of the solenoid coils.

[0073] Figure 5 shows a more detailed version of the control strategy and current waveform of Figure 4 where like numerals denote like features.

[0074] The pull-in (53) and hold (55) phases of operation of the pulse control logic are shown in Figure 5. The left hand foot of the Boost command 35 represents the start of pulse logic.

[0075] It is noted that in existing controller systems, two samples of the current through the actuator coil 7 are taken during the pull-in phase 53 of all valve actuator drive pulses. The first current sample time 57 is approximately 20 microseconds after the start of the Boost command 35 in the present example. The second current sample time 59 is measured after approximately 60% of the interval between the start of the Boost command 35 and the peak current 37. It is noted that for a needle valve this is approximately 220 microseconds after the start of the Boost command 35 and for a spill valve it is approximately 390 microseconds after the start of the Boost command.

[0076] The reason for measuring the first and second current samples (57, 59) is to allow diagnostic tests to be performed on the injector to allow the presence of certain faults to be determined. However, as described below these current samples can be used to determine an approximation of the actuator coil resistance.

[0077] As a result of the varying coil resistance effects described above the rise time of the current waveform 33 during the pull-in phase 53 will be faster at lower temperatures which will result in a higher than normal current sample being recorded at any given sample time.

[0078] Therefore, the current measured at the second current sample time 59 will be higher for lower coil temperatures. This effect is illustrated in Figure 6 in which two current traces, 33_L and 33_H, are shown. 33_L corresponds to a low temperature, low coil resistance trace and 33_H corresponds to a high temperature, high coil

resistance trace.

[0079] As can be seen in the Figure there is a difference in the measured current (represented by the current delta 61) at the second sample time 59.

5 **[0080]** The current measured at the second sample time 59 may also be affected by changes in the voltage that appears across the fully charged capacitor (i.e. the voltage that appears across the capacitor at the time indicated as 63 in Figure 4). For example, if the capacitor voltage is less than the expected 50volts then the measured current at time 59 will be lower than expected for a given temperature.

10 **[0081]** In other words the coil resistance will be indicated by the current at the second current sample time 59 and the voltage that appears across the capacitor at time 63.

15 **[0082]** By measuring both of these variables under different conditions a 2D map of measured current versus capacitor voltage can be built up. For each point on this 2D map the coil resistance can be measured during a calibration phase.

20 **[0083]** In use therefore the ECU 4 can measure the current across the coil 1 (via measurement signal 12) and the voltage that appears across the capacitor 3 prior to capacitor discharge (via measurement signal 10) and can then look up the coil resistance from the 2D map.

25 **[0084]** The coil resistance can be linked to the Boost re-drive activation voltage threshold via a further (1D) map. If the coil resistance is low then the activation voltage threshold will be high and vice versa.

30 **[0085]** The 1 D map may be calibrated during a test bench phase (in a similar manner to the 2D map calibration).

35 **[0086]** Once the activation threshold has been determined from the 1 D map, the ECU 4 can then compare the current battery voltage (via measurement signal 11) with the activation voltage threshold. If the battery voltage drops below the calculated Boost re-drive voltage threshold then the Boost re-drive strategy can be switched on and the ECU may operate the solenoid valve 1 in the manner shown in Figures 4 and 5.

40 **[0087]** It is noted that the current and voltage measurements taken by the ECU 4 may be passed through first-order filters to reduce noise.

45 **[0088]** It is further noted that a hysteresis band may be established around the activation voltage threshold in order to avoid rapid on/off enabling of the Boost re-drive strategy due to minor voltage fluctuations which may occur.

50 **[0089]** If the battery voltage rises above the activation voltage threshold (+ the hysteresis band if there is one) the Boost re-drive strategy can be stopped by the ECU 4.

55 **[0090]** Figure 7 shows an example of the 2D map used to determine the coil resistance. The current measurement at the second sample time 59 is on the x-axis and the voltage across the capacitor at the time 63 is on the y-axis. For each map point the resistance across the solenoid coil 7 is shown. These resistance values can be

determined during a test bench phase and the map can later be used by the ECU 4.

[0091] Figure 8 shows an example of the 1D map used to determine the activation voltage threshold in dependence on the value of the coil resistance determined from Figure 7.

[0092] Figures 9 and 10 are block diagram representations of the data flow within the ECU software. Software variables enter the module at the left via the in-ports, and flow from left to right along the signal lines (black lines with arrows). The variable name is listed below the in-port. Software constants are represented as boxes with the constant name within the box. All other mathematical functions (addition, multiplication, look-up tables, and so on) are represented as blocks, with the required inputs entering on the left, and the result of the mathematical procedure exiting on the right. This usually results in a new software variable name which is written beneath the new variable signal line, or below the exit port at the far right of the module.

[0093] Figure 9 shows the logic steps involved in the calculation of the coil resistance. On the left, the coil current sample (control signal 12 in Figure 1), comes in through in-port 1, and the boost capacitor voltage signal (control signal 10 in Figure 1), comes in through in-port 2. Both signals are then passed to respective first-order filters to remove signal noise, which must be 'tuned' as part of the calibration process. This is done using the constants on the left, which control the sensitivity of the first-order filters. The filtered signals are then passed to a 2-D calibrated look-up table, labelled REQ-002, where the two input variables of voltage and current are converted into an estimate of coil resistance. Lastly, an upper and lower limit is placed on the coil resistance value as a safe-guard to the rest of the software in case unusual numbers for the coil resistance emerge from the 2-D map (for example, 25 ohm instead of 2.5 ohm is accidentally entered during the calibration process). The resistance estimate is then passed to the Boost Re-drive activation control module (described in relation to Figure 10).

[0094] Figure 10 shows the calculation of the Boost Re-drive activation voltage threshold and logic to determine the state of the Boost Re-drive strategy. The calculated value for the coil resistance (calculated in Figure 9 above) enters through in-port 1 on the far left, and is mapped against the calibrated values for the Boost Re-Drive Activation Voltage level. This voltage level (LVC_Scv_redrive_on_batt) is summed with the constant hysteresis band level at REQ-101 to determine the voltage at which Boost Re-drive is de-activated. Both these voltage levels, along with the recorded battery voltage (found via signal 11 in Figure 1), are passed to the hysteresis logic block at REQ-102. The role of this block is to hold the current activation state (either TRUE or FALSE) until an activation or de-activation condition is met. For example, the Boost Re-drive state will remain FALSE (off) until the battery voltage level 11 falls below the activation threshold. This will in-turn be held TRUE

until the de-activation condition is met (i.e., the battery voltage rises back above the de-activation threshold, set in REQ-101). This is done to prevent rapid on/off switching due to minor battery voltage fluctuations about the Boost Re-drive activation voltage. Lastly, there exists a software switch whereby the whole of the Boost Re-drive system can be disabled (permanently set to FALSE) regardless of the output of the combined software modules (REQ-103). The state of the Boost Re-drive system is output on the far right via out-port 1.

[0095] The embodiments of the present invention described above are illustrated with the ECU 4 receiving the various data measurements and performing the various calculations. However, it will be appreciated by the skilled person that the same principles could be undertaken by a dedicated control unit.

[0096] The embodiments described above in relation to Figures 1, 9 and 10 relate to a Boost redrive control scenario that is controlled by software running on the vehicle's ECU. Figures 11 and 12 show circuit schematics for a hardware implementation of an injector system that uses Boost pulses.

[0097] Figure 11 shows a circuit schematic for a typical fuel injector drive system comprising a low-side switch Q1 connected between load- and ground through a current sense resistor R1, a high-side switch Q2 connected between load+ and the cathode of series diode D1, and a boost switch Q3 connected between cathode of D1 and a boost capacitor (not shown in Figure 11) which is capable of supplying Boost voltage pulses at Vboost. The anode of D1 is connected to the battery supply Vbat. A recirculation diode D2 is connected between ground and load+. A third diode D3 is connected between load- and Vboost. A variation of this circuit may have the boost switch connected in parallel with the high-side switch. In this case the boost switch Q3 is connected between load+ and the Vboost.

[0098] As noted above, a typical control logic and current waveform is shown in Figure 2 where the battery voltage is higher than the voltage necessary to provide the upper hold threshold driving current (I_hold_max). The actuator coil resistance has been carefully chosen so that the lower hold threshold current (I_hold_min) is always available at or above nominal battery voltage (e.g. 14V) even when the coil is at maximum operating temperature (It is noted that the resistance of the copper coil within the solenoid increases with temperature at a rate of about 40% for 100 degC rise).

[0099] In normal operation the low side switch Q1 is turned on for the duration of the pull-in and hold phases (collectively referred to as the INJ_EN pulse). The boost switch Q3 is only turned on during the pull-in current phase (set by the one-shot timer U6) and then remains off during the hold phase. The boost voltage is used to obtain a fast current rise and reduce the pull-in time. The high side switch Q2 gates the boost voltage (when Q3 is on) or battery voltage (when Q3 is off).

[0100] The injector current is sensed by R1 and am-

plified by the op-amp U1. The hold current is maintained between the levels I_{hold_min} and I_{hold_max} by switching the high-side switch Q2 on and off when the current sense comparator U5 thresholds are reached. This is a well known technique known as pulse width modulation (PWM). The comparator threshold levels in this example are selected by an analog multiplexer U7 that selects $I_{peak_min/max}$ or $I_{hold_min/max}$ current thresholds under control of the one-shot peak timer U6 and the state of the comparator PWM output. The AND gate U3C gates the PWM signal with the INJ_EN pulse so that Q1 and Q2 are both turned off when INJ_EN is low to give fast injector de-energisation.

[0101] As noted above, Figure 4 shows the control logic and current waveform when the battery voltage falls below that necessary to maintain the lower hold threshold driving current and the additional boost voltage pulses are being used to augment battery voltage (redrive mode).

[0102] The boost voltage drives the current up to the upper hold threshold driving current where the boost switch Q3 is be turned off. The high-side switch Q2 is turned on continuously during the hold phase so that the recirculation current now flows through the battery instead of through the recirculation diode D2. Comparison of the voltage waveforms in Figures 2 and 4 illustrates the difference in operation.

[0103] This method of operation requires the comparator PWM output to be redirected from the high-side switch to the boost switch and, at the same time, the high-side switch must be turned full on. Figure 12 shows a modified circuit schematic that incorporates additional logic to enable the redrive function during the hold phase. The additional components are shown inside the box 70. The AND gate U3B ensures that when the redrive control strategy is active, the high-side switch is turned off during the time the current decays from peak to hold but is turned on (via OR gate U4B) during the hold phase. The OR gate U4A together with the AND gate U3A steers the PWM to the Boost switch during the hold phase in redrive mode.

[0104] Various strategies may be employed to detect when redrive is required depending on battery voltage and coil resistance (which varies with temperature). Clearly, although one solution has been portrayed, there are many other variations possible using a combination of software and hardware. Although an injector current waveform has been shown with no peak current chopping, the redrive principle is also applicable to injector waveforms with peak current chopping.

[0105] A perceived disadvantage of this method is that the power rating of the DC/DC boost converter (which is used to provide the high voltage source in conjunction with the Boost capacitor) might have to be increased to handle the additional boost pulses during the hold phase. In practice this is not the case for the following reasons:

1. The DC/DC boost converter is rated for full engine

speed whereas redrive normally occurs at cranking where the speed of the engine is very low and therefore the pull-in power is relatively low.

2. The starting phase of the engine is relatively short and the DC/DC converter has an inherent short term overload capability owing to its thermal inertia. As soon as the engine has started, the battery charging system (alternator) quickly restores the battery voltage to its normal voltage range (about 13.5 - 14V on a 12V system) and redrive will be disabled.

3. During redrive mode, the flow of power from the battery into the injector is maintained at an enhanced level and this minimises the amount of power required from the Boost circuit. This is a result of using boost voltage to drive the max hold current to a higher level than V_{bat}/R (which would be the case if the current was purely defined by Ohm's Law) and allowing battery power to flow during the time that the hold current is decaying (i.e. recirculating through the battery).

[0106] As a further improvement, the upper hold threshold current (I_{hold_max}) may be raised during redrive mode in order to limit the chopping frequency, since the current rate of rise is very fast on boost voltage. This causes a slight increase in ripple current but this is not critical during the engine starting procedure. In a normal installation, as soon as the engine has started, the alternator will recharge the battery and quickly reach about 13.5 -14V (on a 12V system) at which point redrive will be disabled.

[0107] It will be understood that the embodiments described above are given by way of example only and are not intended to limit the invention, the scope of which is defined in the appended claims. It will also be understood that the embodiments described may be used individually or in combination.

Claims

1. A controller (4) for controlling the operation of a valve in an engine system, the valve being in communication with a battery (2) and a further voltage supply means (3) and comprising an actuator (1), the controller (4) comprising inputs for receiving data representing the voltage across the battery (2) and further voltage supply means (3) and the current through the actuator (1); a processor programmed to determine a control function for controlling the operation of the valve; and outputs for outputting the control function as determined by the processor to control the operation of the valve, the controller (4) being **characterised in that** the processor is arranged to determine the resistance of the actuator (1) from the data representing the voltage across the further volt-

- age supply means (3) and the current through the actuator (1) and to determine the control function for controlling the operation of the valve in dependence on the voltage across the battery (2) and the resistance of the actuator (1). 5
2. A controller (4) as claimed in Claim 1, wherein the control function is derived from a control voltage pulse structure to be applied to the actuator (1) and the outputs are arranged to output the control function as determined by the processor to the battery (2) and further voltage supply means (3). 10
 3. A controller (4) as claimed in Claim 2, wherein the control voltage pulse structure comprises voltage components from the battery (2) and the further voltage supply means (3). 15
 4. A controller (4) as claimed in Claim 1, wherein the battery (2) and further voltage supply means (3) are controlled by the switching of control switches within an injector drive circuit, the control function being a control sequence for controlling the switching of the control switches. 20
 5. A controller (4) as claimed in any preceding claim, wherein the control function is arranged, in a pull-in phase, to apply a pulse from the further voltage supply means (3) at a first voltage potential across the actuator (1) so that the valve is caused to move from a first state to a second state and is arranged, in a hold phase, to apply a second voltage potential or series of pulses at a second voltage potential from the battery (2) across the actuator (1). 25
 6. A controller (4) as claimed in Claim 5, wherein during the hold phase the control function as determined by the processor is arranged to apply at least one further pulse from the further voltage supply means (3) at a voltage potential greater than the second voltage potential. 30
 7. A controller (4) as claimed in Claim 6, wherein the at least one further pulse is arranged to be applied across the actuator (1) at the first voltage potential. 35
 8. A controller (4) as claimed in Claim 7, wherein, during the hold phase, the control function as determined by the controller (4) is arranged to apply the second voltage potential across the actuator (1) during periods that the at least one further pulse is not being applied. 40
 9. A controller (4) as claimed in any of Claims 6 to 8, wherein: 45
 - (i) the battery (2) and further voltage supply means (3) are controlled by the switching of control switches within an injector drive circuit, the control function being a control sequence for controlling the switching of the control switches; 50
 - (ii) the injector drive circuit comprises: a high side switch (6) arranged to gate either the voltage potential from the battery (2) or the at least one further pulse from the further voltage supply means (3) and a boost switch (5) arranged to control the at least one further pulse from the further voltage supply means (3); 55

such that, during the hold phase, the control function is arranged to send a series of control pulses to the boost switch (5) and to turn the high side switch (6) on.
 10. A controller (4) as claimed in any of Claims 5 to 9, the controller further comprising a first function map detailing the resistance of the actuator (1) in dependence upon the voltage across the further voltage supply means (3) and the current through the actuator (1) and a second function map detailing an activation voltage for applying at least one further pulse at the first voltage potential during the hold phase as a function of the resistance of the actuator (1) and wherein the processor is arranged to determine whether to apply at least one further pulse at the first voltage potential during the hold phase by:
 - (i) determining the resistance of actuator (1) from the first function map
 - (ii) determining the activation voltage from the second map
 - (iii) applying at least one further pulse during the hold phase when the battery voltage falls below the activation voltage.
 11. A controller (4) as claimed in Claim 10, wherein the first and second function mode maps comprise predetermined data calibrated during one or more test phases.
 12. A controller (4) as claimed in Claim 10 or Claim 11, wherein the controller (4) is arranged to measure the voltage across the further voltage supply means (3) when fully charged and is arranged to measure the current passing through the actuator (1) during the pull-in phase, the measured voltage and current levels being used to determine the resistance of the actuator (1) from the first function map.
 13. A controller (4) as claimed in any of Claims 10 to 12, wherein the processor is arranged to determine a deactivation voltage by adding a hysteresis voltage amount to the activation voltage and is arranged to continue applying at least one further pulse until the battery voltage rises above the deactivation voltage.

14. A controller (4) as claimed in any of Claims 5 to 13, wherein the controller (4) measures the voltage across the further voltage supply means (3) prior to initiation of a pull-in phase.
15. A controller (4) as claimed in any of Claims 5 to 14, wherein the controller (4) is arranged to measure the current through the actuator (1) at approximately 60% of the interval between the start of the pull-in phase and peak pull-in current.
16. A controller (4) as claimed in Claim 15, wherein the controller (4) is arranged to measure the current through the actuator (1) at 200-400 microseconds after start of a pull-in phase.
17. A controller (4) as claimed in any of Claims 5 to 16, wherein the control function is arranged to maintain the current through the actuator (1) between upper and lower hold thresholds during the hold phase.
18. A controller (4) as claimed in any preceding claim, wherein the actuator (1) comprises a solenoid coil.
19. A controller (4) as claimed in any preceding claim, wherein the further voltage supply means (3) comprises a capacitor.
20. An engine control unit for a vehicle comprising a controller (4) according to any preceding claim.
21. A vehicle injection system comprising a controller (4) according to any of Claims 1 to 19.
22. A vehicle injection system comprising a controller (4) according to any of Claims 1 to 19 and at least one solenoid valve (1), the operation of the at least one solenoid valve (1) being controlled by the controller (4), a battery (2) having a normal operating voltage of V_{BAT} and a further voltage supply means (3), wherein

(i) the controller (4) comprises a processor programmed to determine a control function for controlling the operation of the at least one solenoid valve (1), the control function being arranged, in a pull-in phase, to apply a pulse from the further voltage supply means (3) at a first voltage potential across the at least one solenoid valve (1) so that the solenoid valve (1) is caused to move from a first state to a second state and is arranged, in a hold phase, to apply a second voltage potential or series of pulses at a second voltage potential from the battery (2) across the at least one solenoid valve (1);

(ii) during the hold phase the control function as determined by the processor is arranged to apply at least one further pulse at a voltage poten-

tial greater than the second voltage potential, and;

(iii) each at least one solenoid valve (1) comprises a coil of n turns, the number of turns n being determined by the normal operating voltage V_{BAT} of the battery (2).

23. A method of controlling the operation of a valve in an engine system, the valve being in communication with a battery (2) and a further voltage supply means (3) and comprising an actuator (1), the method comprising:

receiving data representing the voltage across the battery (2) and the voltage across the further voltage supply means (3);

receiving data representing the current through the actuator (1);

wherein the method is **characterised by**:

determining the resistance of the actuator (1) from the data representing the voltage across the further voltage supply means (3) and the current through the actuator (1);

determining a control function for controlling the operation of the valve in dependence on the voltage across the further voltage supply means (3) and the resistance of the actuator (1), and;

outputting the control function to the battery (2) and further voltage supply means (3).

Patentansprüche

1. Eine Steuervorrichtung (4) zum Steuern des Betriebs eines Ventils in einem Motorsystem, wobei das Ventil in Kommunikation mit einer Batterie (2) und einem weiteren Spannungsversorgungsmittel (3) ist und einen Aktuator (1) aufweist, wobei die Steuervorrichtung (4) Eingänge aufweist zum Empfangen von Daten, die die Spannung über der Batterie (2) und dem weiteren Spannungsversorgungsmittel (3) und den Strom durch den Aktuator (1) repräsentieren; einen Prozessor, der programmiert ist zum Bestimmen einer Steuerfunktion zum Steuern des Betriebs des Ventils; und Ausgänge zum Ausgeben der Steuerfunktion, wie durch den Prozessor bestimmt, zum Steuern des Betriebs des Ventils, wobei die Steuervorrichtung (4) **dadurch gekennzeichnet ist, dass** der Prozessor ausgebildet ist zum Bestimmen des Widerstands des Aktuators (1) aus den Daten, die die Spannung über dem weiteren Spannungsversorgungsmittel (3) und den Strom durch den Aktuator (1) repräsentieren, und zum Bestimmen der Steuerfunktion zum Steuern des Betriebs des Ventils in Abhängigkeit von der Spannung über der Batterie (2) und dem Widerstand des Aktuators

- (1).
2. Eine Steuervorrichtung (4) gemäß Anspruch 1, wobei die Steuerfunktion von einer Steuerspannungspulsstruktur zur Anwendung auf den Aktuator (1) abgeleitet ist und die Ausgänge ausgebildet sind zum Ausgeben der Steuerfunktion, wie durch den Prozessor bestimmt, an die Batterie (2) und das weitere Spannungsversorgungsmittel (3). 5
3. Eine Steuervorrichtung (4) gemäß Anspruch 2, wobei die Steuerspannungspulsstruktur Spannungs-komponenten von der Batterie (2) und dem weiteren Spannungsversorgungsmittel (3) aufweist. 10
4. Eine Steuervorrichtung (4) gemäß Anspruch 1, wobei die Batterie (2) und das weitere Spannungsversorgungsmittel (3) durch das Schalten von Steuer-schaltern in einer Injektortreiberschaltung gesteuert werden, wobei die Steuerfunktion eine Steuer-sequenz zum Steuern des Schaltens der Steuerschal-ter ist. 20
5. Eine Steuervorrichtung (4) gemäß einem vorhergehenden Anspruch, wobei die Steuerfunktion ausge-bildet ist, in einer Pull-in-Phase, zum Anwenden ei-nes Pulses von dem weiteren Spannungsversor-gungsmittel (3) an einem ersten Spannungspotential über den Aktuator (1) derart, dass veranlasst wird, dass das Ventil von einem ersten Zustand in einen zweiten Zustand geht, und ausgebildet ist, in einer Haltephase, zum Anwenden eines zweiten Span-nungspotentials oder einer Serie von Pulsen an ei-nem zweiten Spannungspotential von der Batterie (2) über den Aktuator (1). 30
6. Eine Steuervorrichtung (4) gemäß Anspruch 5, wo-bei, während der Haltephase, die Steuerfunktion, wie durch den Prozessor bestimmt, ausgebildet ist zum Anwenden zumindest eines weiteren Pulses von dem weiteren Spannungsversorgungsmittel (3) an einem Spannungspotential, das größer ist als das zweite Spannungspotential. 40
7. Eine Steuervorrichtung (4) gemäß Anspruch 6, wo-bei der zumindest eine weitere Puls ausgebildet ist, über den Aktuator (1) an dem ersten Spannungspo-tential angewendet zu werden. 45
8. Eine Steuervorrichtung (4) gemäß Anspruch 7, wo-bei, während der Haltephase, die Steuerfunktion, wie durch die Steuervorrichtung (4) bestimmt, aus-gebildet ist zum Anwenden des zweiten Spannungs-potentials über den Aktuator (1) während Perioden, während der der zumindest eine weitere Puls nicht angewendet wird. 50
9. Eine Steuervorrichtung (4) gemäß einem der An-sprüche 6 bis 8, wobei:
- (i) die Batterie (2) und das weitere Spannungs-versorgungsmittel (3) durch das Schalten von Steuerschaltern in einer Injektortreiberschaltung gesteuert werden, wobei die Steuerfunkt-ion eine Steuersequenz zum Steuern des Schaltens der Steuerschalter ist;
- (ii) die Injektortreiberschaltung aufweist: einen hochseitigen Schalter (6), der ausgebildet ist zum Steuern entweder des Spannungspotential-s von der Batterie (2) oder des zumindest ein-nen weiteren Pulses von dem weiteren Span-nungsversorgungsmittel (3), und einen Boost-Schalter (5), der ausgebildet ist zum Steuern des zumindest einen weiteren Pulses von dem weiteren Spannungsversorgungsmittel (3);
- derart dass, während der Haltephase, die Steuer-funktion ausgebildet ist zum Senden einer Serie von Steuerpulsen an den Boost-Schalter (5) und Ein-schalten des High-Side-Schalters (6).
10. Eine Steuervorrichtung (4) gemäß einem der An-sprüche 5 bis 9, wobei die Steuervorrichtung weiter eine erste Funktionskarte aufweist, die den Wider-stand des Aktuators (1) in Abhängigkeit von der Spannung über dem weiteren Spannungsversor-gungsmittel (3) und dem Strom durch den Aktuator (1) detailliert, und eine zweite Funktionskarte, die eine Aktivierungsspannung zum Anwenden zumin-dest eines weiteren Pulses an dem ersten Span-nungspotential während der Haltephase als eine Funktion des Widerstands des Aktuators (1) detail-liert, und wobei der Prozessor ausgebildet ist zum Bestimmen, ob zumindest ein weiterer Puls an dem ersten Spannungspotential während der Haltephase anzuwenden ist, durch:
- (i) Bestimmen des Widerstands des Aktuators (1) aus der ersten Funktionskarte,
- (ii) Bestimmen der Aktivierungsspannung aus der zweiten Karte,
- (iii) Anwenden zumindest eines weiteren Pulses während der Haltephase, wenn die Batterie-spannung unter die Aktivierungsspannung fällt.
11. Eine Steuervorrichtung (4) gemäß Anspruch 10, wo-bei die ersten und zweiten Funktionsmoduskarten vorgegebene Daten aufweisen, die während einer oder mehrerer Testphasen kalibriert werden.
12. Eine Steuervorrichtung (4) gemäß Anspruch 10 oder Anspruch 11, wobei die Steuervorrichtung (4) aus-gebildet ist zum Messen der Spannung über das wei-tere Spannungsversorgungsmittel (3), wenn voll-ständig aufgeladen, und ausgebildet ist zum Messen des Stroms, der durch den Aktuator (1) fließt wäh-

rend der Pull-in-Phase, wobei die gemessenen Spannungs- und Strompegel verwendet werden zum Bestimmen des Widerstands des Aktuators (1) aus der ersten Funktionskarte.

- 5
13. Eine Steuervorrichtung (4) gemäß einem der Ansprüche 10 bis 12, wobei der Prozessor ausgebildet ist zum Bestimmen einer Deaktivierungsspannung durch Hinzufügen einer Hysteresespannungsgröße zu der Aktivierungsspannung, und ausgebildet ist zum weiterhin Anwenden zumindest eines weiteren Pulses, bis die Batteriespannung über die Deaktivierungsspannung steigt. 10
14. Eine Steuervorrichtung (4) gemäß einem der Ansprüche 5 bis 13, wobei die Steuervorrichtung (4) die Spannung über dem weiteren Spannungsversorgungsmittel (3) vor einer Initiierung einer Pull-in-Phase misst. 15
15. Eine Steuervorrichtung (4) gemäß einem der Ansprüche 5 bis 14, wobei die Steuervorrichtung (4) ausgebildet ist zum Messen des Stroms durch den Aktuator (1) bei ungefähr 60% des Intervalls zwischen dem Beginn der Pull-in-Phase und einem Spitzen-Pull-in-Strom. 20 25
16. Eine Steuervorrichtung (4) gemäß Anspruch 15, wobei die Steuervorrichtung (4) ausgebildet ist zum Messen des Stroms durch den Aktuator (1) bei 200-400 Mikrosekunden nach dem Start einer Pull-in-Phase. 30
17. Eine Steuervorrichtung (4) gemäß einem der Ansprüche 5 bis 16, wobei die Steuerfunktion ausgebildet ist zum Halten des Stroms durch den Aktuator (1) zwischen oberen und unteren Halteschwellen während der Haltephase. 35
18. Eine Steuervorrichtung (4) gemäß einem vorhergehenden Anspruch, wobei der Aktuator (1) eine Magnetspule aufweist. 40
19. Eine Steuervorrichtung (4) gemäß einem vorhergehenden Anspruch, wobei das weitere Spannungsversorgungsmittel (3) einen Kondensator aufweist. 45
20. Eine Motorsteuereinheit für ein Fahrzeug mit einer Steuervorrichtung (4) gemäß einem vorhergehenden Anspruch. 50
21. Ein Fahrzeugeinspritzsystem mit einer Steuervorrichtung (4) gemäß einem der Ansprüche 1 bis 19.
22. Ein Fahrzeugeinspritzsystem, das eine Steuervorrichtung (4) gemäß einem der Ansprüche 1 bis 19 und zumindest ein Magnetventil (1) aufweist, wobei der Betrieb des zumindest einen Magnetventils (1)

durch die Steuervorrichtung (4), eine Batterie (2) mit einer normalen Betriebsspannung von V_{BAT} und einem weiteren Spannungsversorgungsmittel (3) gesteuert wird, wobei

- (i) die Steuervorrichtung (4) einen Prozessor aufweist, der programmiert ist zum Bestimmen einer Steuerfunktion zum Steuern des Betriebs des zumindest einen Magnetventils (1), wobei die Steuerfunktion ausgebildet ist, in einer Pull-in-Phase, zum Anwenden eines Pulses von dem weiteren Spannungsversorgungsmittel (3) an einem ersten Spannungspotential über das zumindest eine Magnetventil (1) derart, dass veranlasst wird, dass das Magnetventil (1) von einem ersten Zustand in einen zweiten Zustand geht, und ausgebildet ist, in einer Haltephase, zum Anwenden eines zweiten Spannungspotentials oder einer Serie von Pulsen an einem zweiten Spannungspotential von der Batterie (2) über das zumindest eine Magnetventil (1);
- (ii) während der Haltephase, die Steuerfunktion, wie durch den Prozessor bestimmt, ausgebildet ist zum Anwenden zumindest eines weiteren Pulses an einem Spannungspotential, das größer ist als das zweite Spannungspotential; und
- (iii) jedes zumindest eine Magnetventil (1) eine Spule mit n Wicklungen aufweist, wobei die Anzahl von Wicklungen n durch die normale Betriebsspannung V_{BAT} der Batterie (2) bestimmt wird.

23. Ein Verfahren zum Steuern des Betriebs eines Ventils in einem Motorsystem, wobei das Ventil in Kommunikation mit einer Batterie (2) und einem weiteren Spannungsversorgungsmittel (3) ist und einen Aktuator (1) aufweist, wobei das Verfahren aufweist:

Empfangen von Daten, die die Spannung über der Batterie (2) und die Spannung über dem weiteren Spannungsversorgungsmittel (3) repräsentieren;

Empfangen von Daten, die den Strom durch den Aktuator (1) repräsentieren;

wobei das Verfahren **gekennzeichnet ist durch:**

Bestimmen des Widerstands des Aktuators (1) aus den Daten, die die Spannung über dem weiteren Spannungsversorgungsmittel (3) und den Strom durch den Aktuator (1) repräsentieren;

Bestimmen einer Steuerfunktion zum Steuern des Betriebs des Ventils in Abhängigkeit von der Spannung über dem weiteren Spannungsversorgungsmittel (3) und dem Widerstand des Aktuators (1); und

Ausgeben der Steuerfunktion an die Batterie (2).

rie (2) und das weitere Spannungsversorgungs-
mittel (3).

Revendications

1. Contrôleur (4) pour commander le fonctionnement d'une valve dans un système moteur, la valve étant en communication avec une batterie (2) et avec un autre moyen de fourniture de voltage (3) et comprenant un actionneur (1), le contrôleur (4) comprenant des entrées pour recevoir des données représentant le voltage aux bornes de la batterie (2) et de l'autre moyen de fourniture de voltage (3) et le courant à travers l'actionneur (1) ; un processeur programmé pour déterminer une fonction de commande pour commander le fonctionnement de la valve ; et des sorties pour délivrer la fonction de commande telle que déterminée par le processeur pour commander le fonctionnement de la valve, le contrôleur (4) étant **caractérisé en ce que** le processeur est agencé pour déterminer la résistance de l'actionneur (1) à partir des données représentant le voltage aux bornes de l'autre moyen de fourniture de voltage (3) et le courant à travers l'actionneur (1) et pour déterminer la fonction de commande pour commander le fonctionnement de la valve en dépendance du voltage aux bornes de la batterie (2) et de la résistance de l'actionneur (1).
2. Contrôleur (4) selon la revendication 1, dans lequel la fonction de commande est dérivée d'une structure d'impulsion de voltage de commande à appliquer à l'actionneur (1) et les sorties sont agencées pour délivrer la fonction de commande telle que déterminée par le processeur à la batterie (2) et à l'autre moyen de fourniture de voltage (3).
3. Contrôleur (4) selon la revendication 2, dans lequel la structure d'impulsion de voltage de commande comprend des composants de voltage venant de la batterie (2) et de l'autre moyen de fourniture de voltage (3).
4. Contrôleur (4) selon la revendication 1, dans lequel la batterie (2) et l'autre moyen de fourniture de voltage (3) sont commandés par la commutation de commutateurs de commande à l'intérieur d'un circuit de pilotage d'injecteur, la fonction de commande étant une séquence de commande pour commander la commutation des commutateurs de commande.
5. Contrôleur (4) selon l'une quelconque des revendications précédentes, dans lequel la fonction de commande est agencée, dans une phase d'appel, pour appliquer une impulsion venant de l'autre moyen de fourniture de voltage (3) à un premier potentiel de voltage à travers l'actionneur (1), de sorte que la valve est amenée à se déplacer depuis un premier état vers un second état et est agencée, dans une phase de maintien, pour appliquer un second potentiel de voltage ou une série d'impulsions à un second potentiel de voltage depuis la batterie (2) à travers l'actionneur (1).
6. Contrôleur (4) selon la revendication 5, dans lequel pendant la phase de maintien la fonction de commande telle que déterminée par le processeur est agencée pour appliquer au moins une autre impulsion venant de l'autre moyen de fourniture de voltage (3) à un potentiel de voltage plus élevé que le second potentiel de voltage.
7. Contrôleur (4) selon la revendication 6, dans lequel ladite au moins une autre impulsion est agencée pour être appliquée à travers l'actionneur (1) au premier potentiel de voltage.
8. Contrôleur (4) selon la revendication 7, dans lequel, pendant la phase de maintien, la fonction de commande telle que déterminée par le contrôleur (4) est agencée pour appliquer le second potentiel de voltage à travers l'actionneur (1) pendant des périodes pendant lesquelles ladite au moins une autre impulsion n'est pas appliquée.
9. Contrôleur (4) selon l'une quelconque des revendications 6 à 8, dans lequel :
 - (i) la batterie (2) et l'autre moyen de fourniture de voltage (3) sont commandés par la commutation de commutateurs de commande à l'intérieur d'un circuit de pilotage d'injecteur, la fonction de commande étant une séquence de commande pour commander la commutation des commutateurs de commande ;
 - (ii) le circuit de pilotage d'injecteur comprend :
 - un commutateur côté haute tension (6) agencé pour ouvrir une porte soit au potentiel de voltage venant de la batterie (2) soit à ladite au moins une autre impulsion venant de l'autre moyen de fourniture de voltage (3), et un commutateur amplificateur (5) agencé pour commander ladite au moins une autre impulsion venant de l'autre moyen de fourniture de voltage (3) ;
 - de telle façon que pendant la phase de maintien, la fonction de commande est agencée pour envoyer une série d'impulsions de commande au commutateur amplificateur (5) et pour activer le commutateur côté haute tension (6).
10. Contrôleur (4) selon l'une quelconque des revendications 5 à 9, le contrôleur comprenant en outre une

première carte de fonction qui détaille la résistance de l'actionneur (1) en dépendance du voltage aux bornes de l'autre moyen de fourniture de voltage (3) et le courant à travers l'actionneur (1) et une seconde carte de fonction qui détaille un voltage d'activation pour appliquer au moins une autre impulsion au premier potentiel de voltage pendant la phase de maintien en tant que fonction de la résistance de l'actionneur (1), et dans lequel le processeur est agencé pour déterminer s'il s'agit d'appliquer au moins une autre impulsion au premier potentiel de voltage pendant la phase de maintien :

- (i) en déterminant la résistance de l'actionneur (1) à partir de la première carte de fonction,
 - (ii) en déterminant le voltage d'activation à partir de la seconde carte,
 - (iii) en appliquant au moins une autre impulsion pendant la phase de maintien quand le voltage de la batterie tombe au-dessous du voltage d'activation.
11. Contrôleur (4) selon la revendication 10, dans lequel la première et la seconde carte de mode de fonction comprennent des données prédéterminées qui sont calibrées pendant une ou plusieurs phases de test.
12. Contrôleur (4) selon la revendication 10 ou 11, dans lequel le contrôleur (4) est agencé pour mesurer le voltage aux bornes de l'autre moyen de fourniture de voltage (3) lorsqu'il est entièrement chargé et est agencé pour mesurer le courant qui passe à travers l'actionneur (1) pendant la phase d'appel, le voltage mesuré et les niveaux de courant étant utilisés pour déterminer à résistance de l'actionneur (1) à partir de la première carte de fonction.
13. Contrôleur (4) selon l'une quelconque des revendications 10 à 12, dans lequel le processeur est agencé pour déterminer un voltage de désactivation en ajoutant une quantité de voltage d'hystérésis au voltage d'activation et est agencé pour continuer à appliquer au moins une autre impulsion jusqu'à ce que le voltage de batterie monte au-dessus du voltage de désactivation.
14. Contrôleur (4) selon l'une quelconque des revendications 5 à 13, dans lequel le contrôleur (4) mesure le voltage aux bornes de l'autre moyen de fourniture de voltage (3) avant démarrage d'une phase d'appel.
15. Contrôleur (4) selon l'une quelconque des revendications 5 à 14, dans lequel le contrôleur (4) est agencé pour mesurer le courant à travers l'actionneur (1) à approximativement 60 % de l'intervalle entre le démarrage de la phase d'appel et la pointe du courant d'appel.

16. Contrôleur (4) selon la revendication 15, dans lequel le contrôleur (4) est agencé pour mesurer le courant à travers l'actionneur (1) à 200 à 400 μ s après démarrage d'une phase d'appel.
17. Contrôleur (4) selon l'une quelconque des revendications 5 à 16, dans lequel la fonction de commande est agencée pour maintenir le courant à travers l'actionneur (1) entre un seuil de maintien supérieur et un seuil de maintien inférieur pendant la phase de maintien.
18. Contrôleur (4) selon l'une quelconque des revendications précédentes, dans lequel l'actionneur (1) comprend une bobine de solénoïde.
19. Contrôleur (4) selon l'une quelconque des revendications précédentes, dans lequel l'autre moyen de fourniture de voltage (3) comprend une capacité.
20. Unité de commande moteur pour un véhicule comprenant un contrôleur (4) selon l'une quelconque des revendications précédentes.
21. Système d'injection de véhicule comprenant un contrôleur (4) selon l'une quelconque des revendications 1 à 19.
22. Système d'injection de véhicule comprenant un contrôleur (4) selon l'une quelconque des revendications 1 à 19 et au moins une valve solénoïde (1), le fonctionnement de ladite au moins une valve solénoïde (1) étant commandé par le contrôleur (4), une batterie (2) ayant un voltage de fonctionnement normal V_{BAT} , et un autre moyen de fourniture de voltage (3), dans lequel
- (i) le contrôleur (4) comprend un processeur programmé pour déterminer une fonction de commande pour commander le fonctionnement de ladite au moins une valve solénoïde (1), la fonction de commande étant agencée, dans une phase d'appel, pour appliquer une impulsion depuis l'autre moyen de fourniture de voltage (3) à un premier potentiel de voltage à travers ladite au moins une valve solénoïde (1) de sorte que la valve solénoïde (1) est amenée à se déplacer depuis le premier état jusqu'à un second état et est agencée, dans une phase de maintien, pour appliquer un second potentiel de voltage ou une série d'impulsions à un second potentiel de voltage depuis la batterie (2) à travers ladite au moins une valve solénoïde (1) ;
 - (ii) pendant la phase de maintien, la fonction de commande telle que déterminée par le processeur est agencée pour appliquer au moins une autre impulsion à un potentiel de voltage plus élevé que le second potentiel de voltage, et

(iii) chacune de ladite au moins une valve solénoïde (1) comprend une bobine de n spires, le nombre de spires n étant déterminé par le voltage fonctionnement normal V_{BAT} de la batterie (2).

5

23. Procédé pour commander le fonctionnement d'une valve dans un système moteur, la valve étant en communication avec une batterie (2) et un autre moyen de fourniture de voltage (3) et comprenant un actionneur (1), le procédé comprenant les étapes consistant à :

10

recevoir des données représentant le voltage aux bornes de la batterie (2) et le voltage aux bornes de l'autre moyen de fourniture de voltage (3) ;
recevoir des données représentant le courant à travers l'actionneur (1) ;

15

20

dans lequel le procédé est **caractérisé par** les étapes consistant à :

déterminer la résistance de l'actionneur (1) à partir des données représentant le voltage aux bornes de l'autre moyen de fourniture de voltage (3) et le courant à travers l'actionneur (1) ;
déterminer une fonction de commande pour commander le fonctionnement de la valve en dépendance du voltage aux bornes de l'autre moyen de fourniture de voltage (3) et la résistance de l'actionneur (1), et
délivrer la fonction de commande à la batterie (2) et à l'autre moyen de fourniture de voltage (3).

25

30

35

40

45

50

55

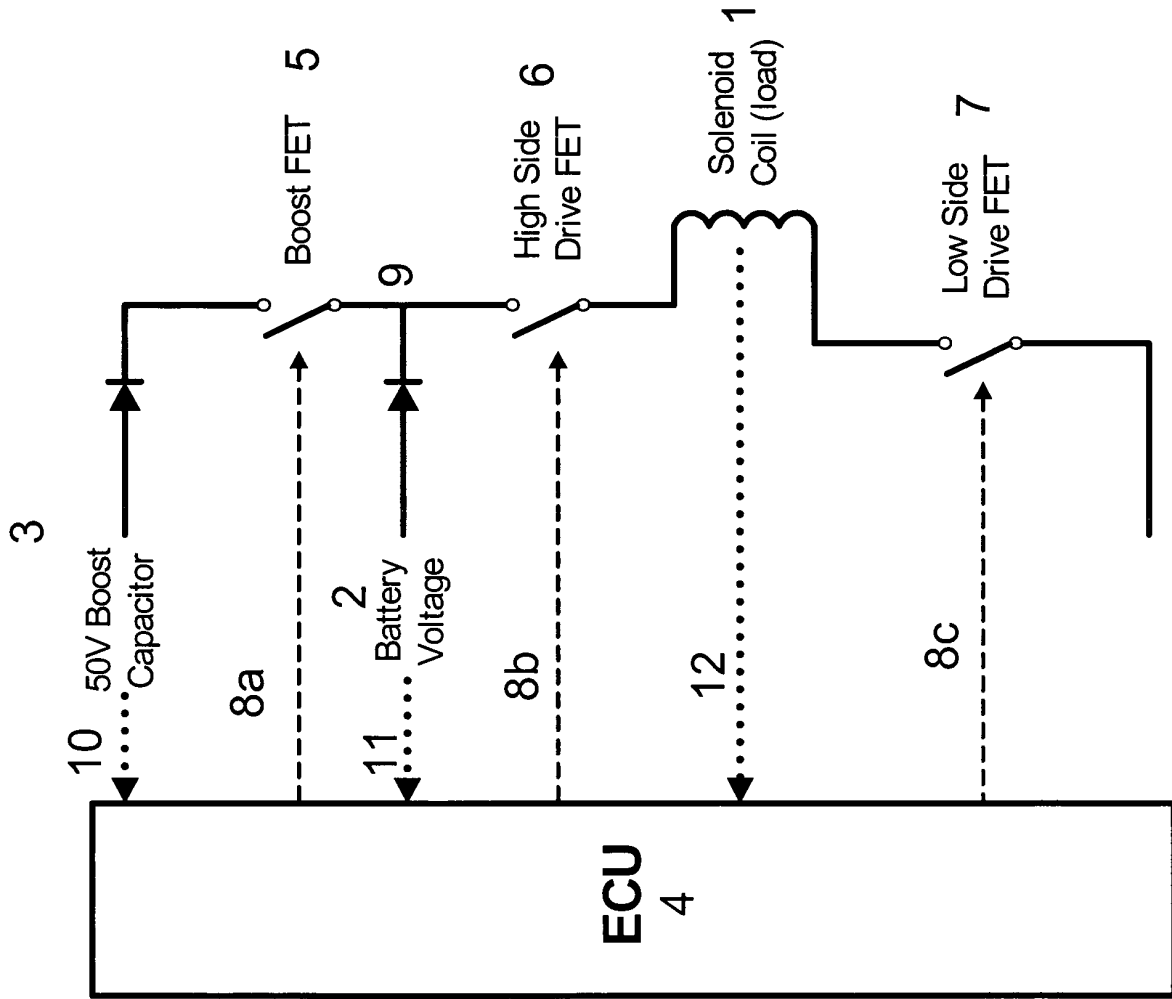

FIGURE 1

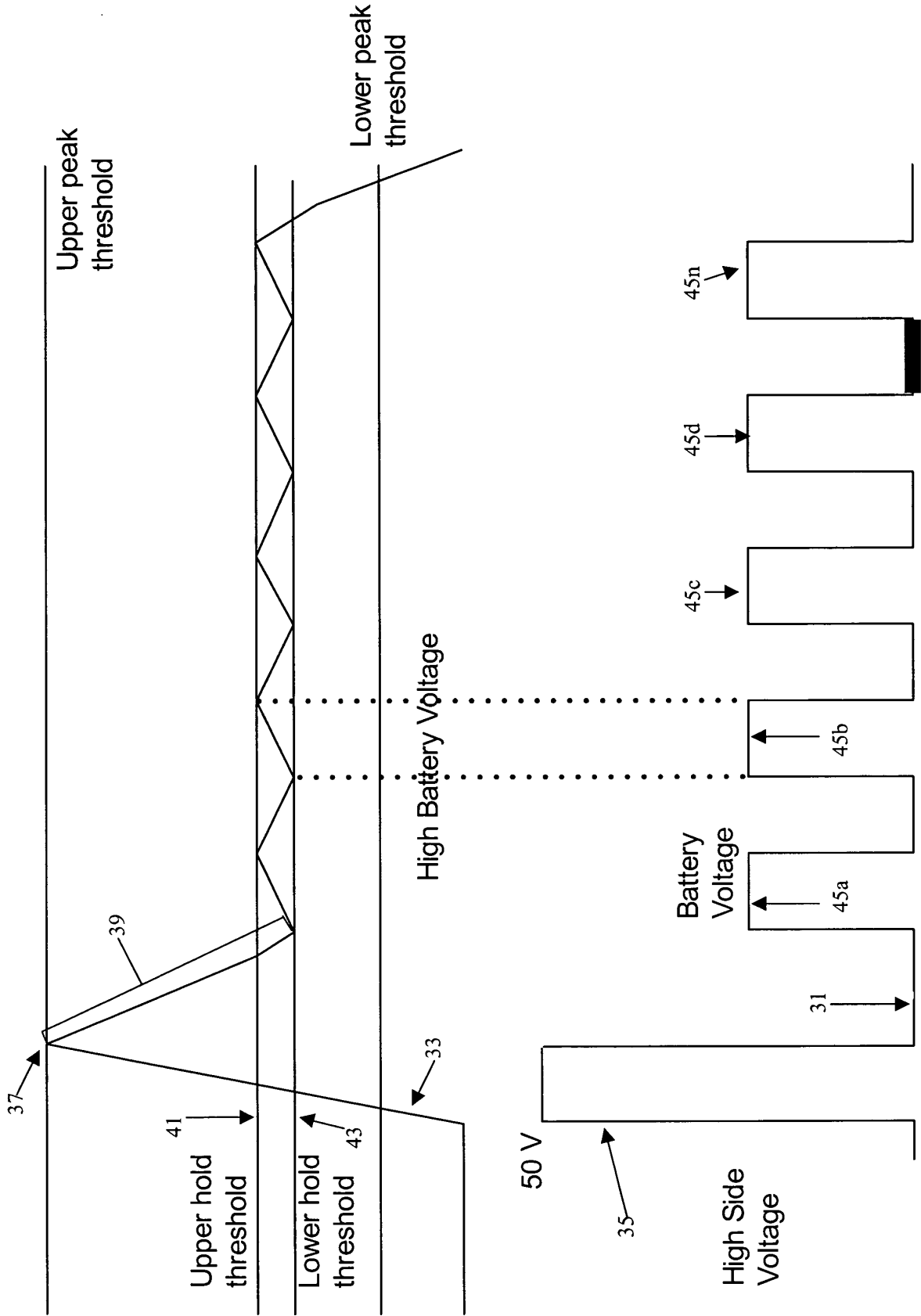

FIGURE 2

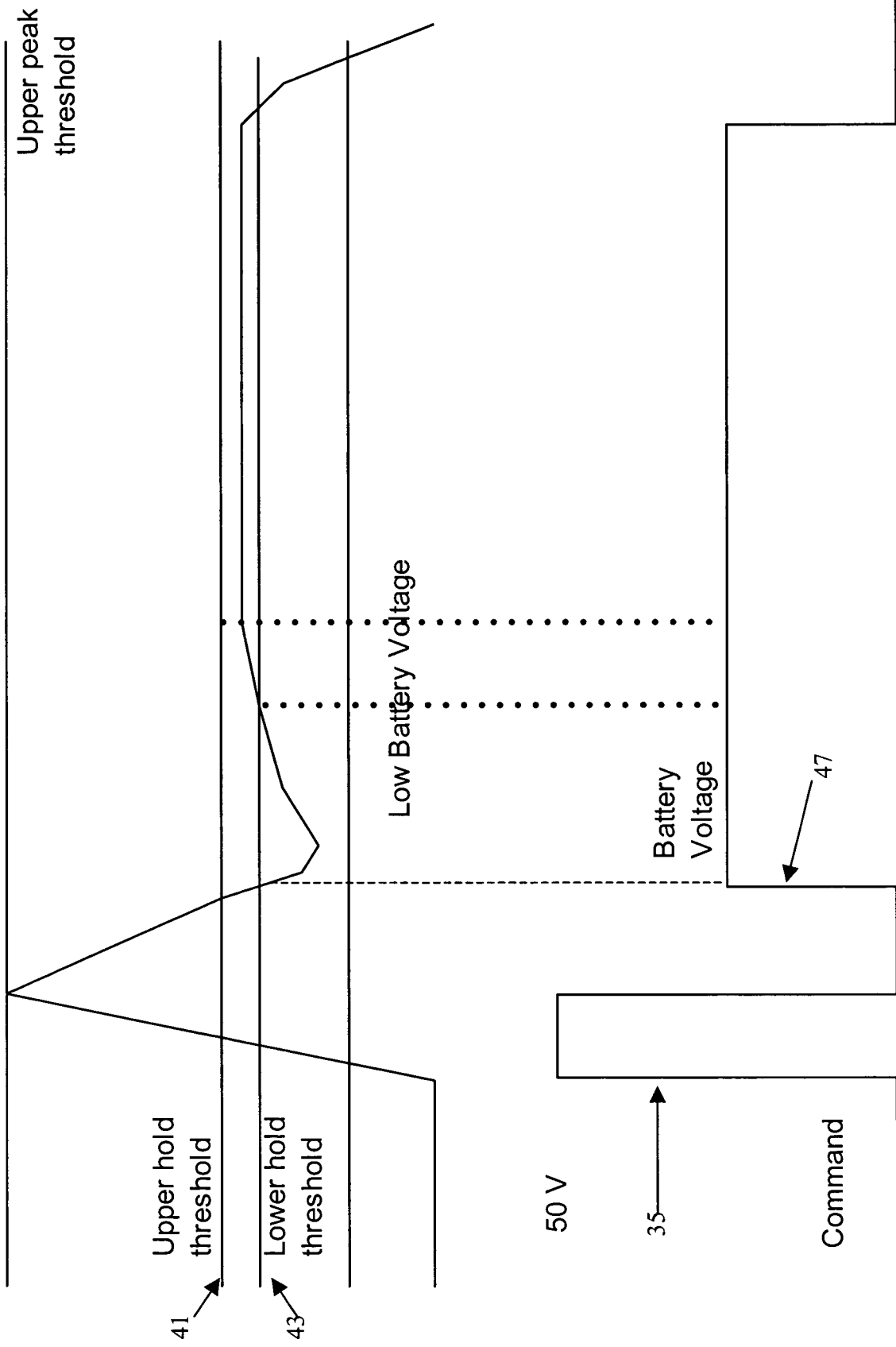

FIGURE 3

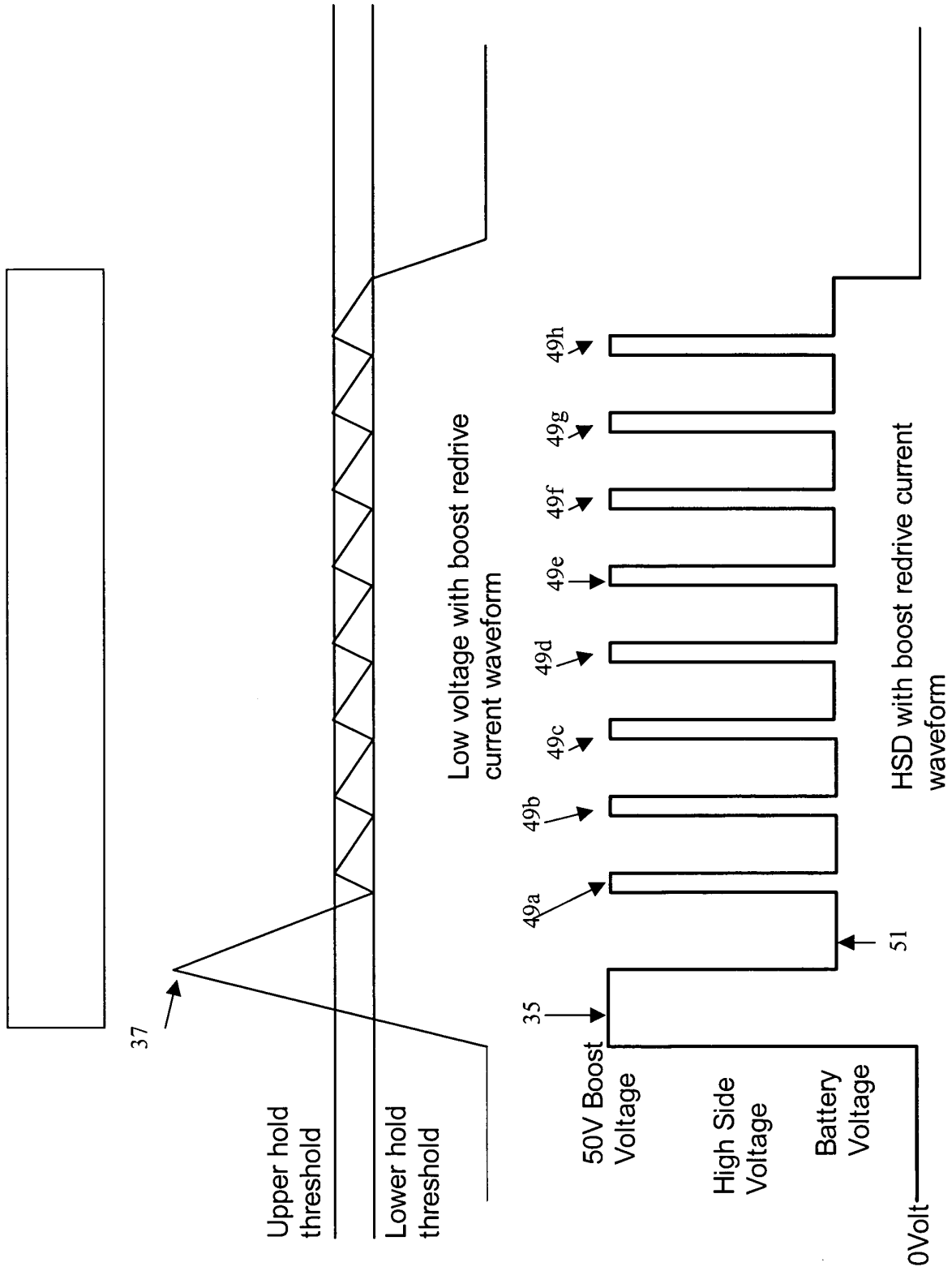

FIGURE 4

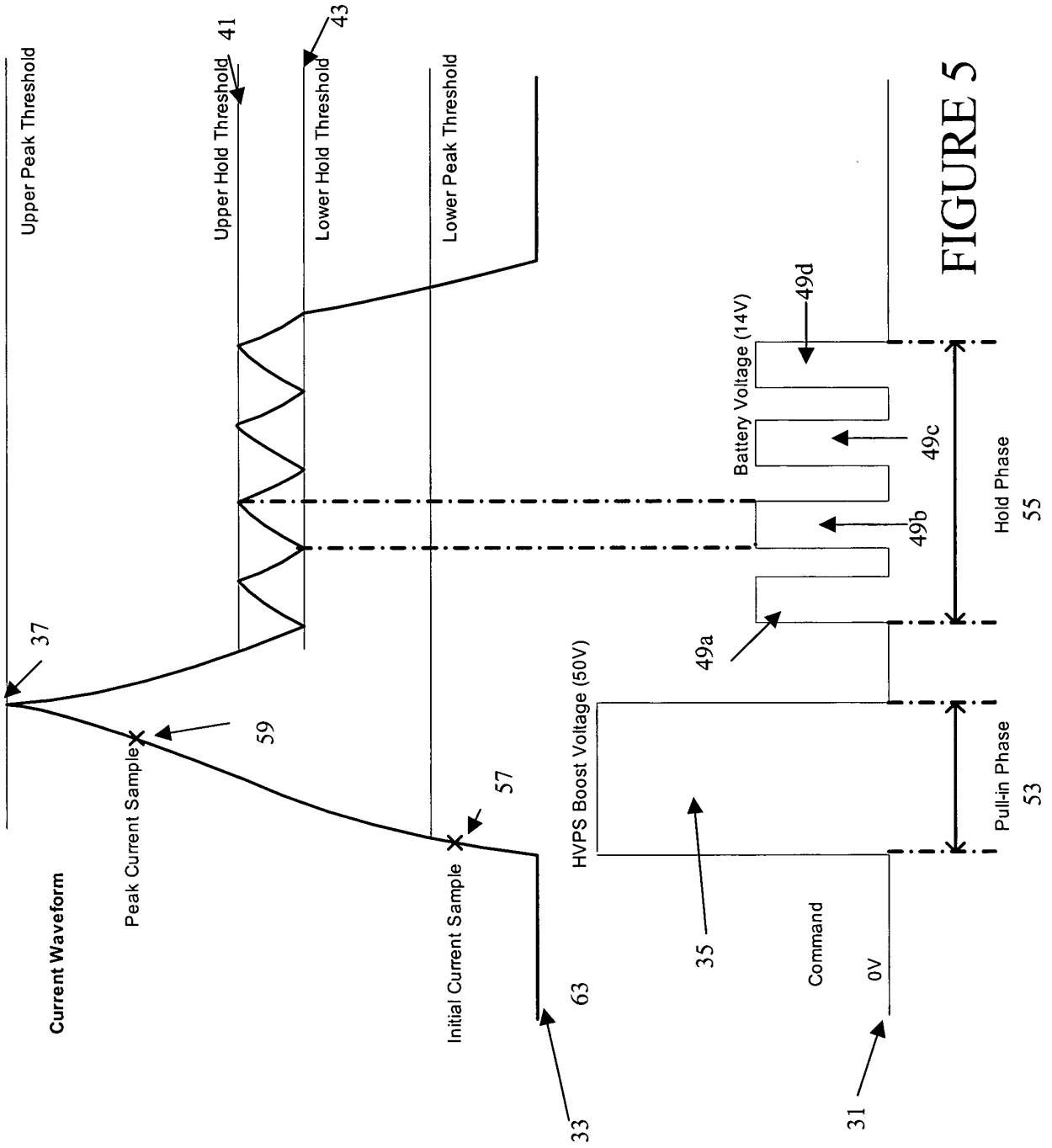

FIGURE 5

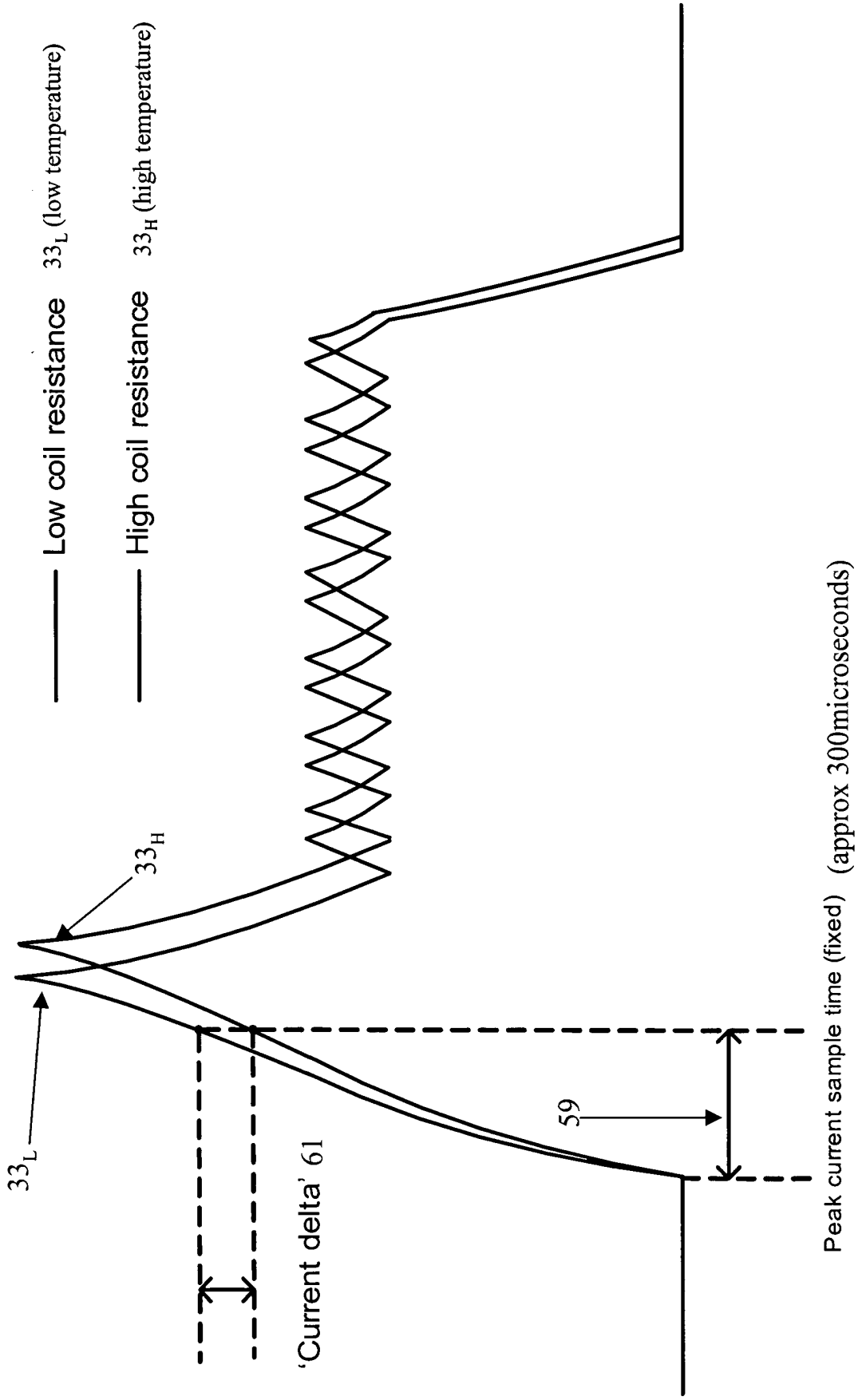

FIGURE 6

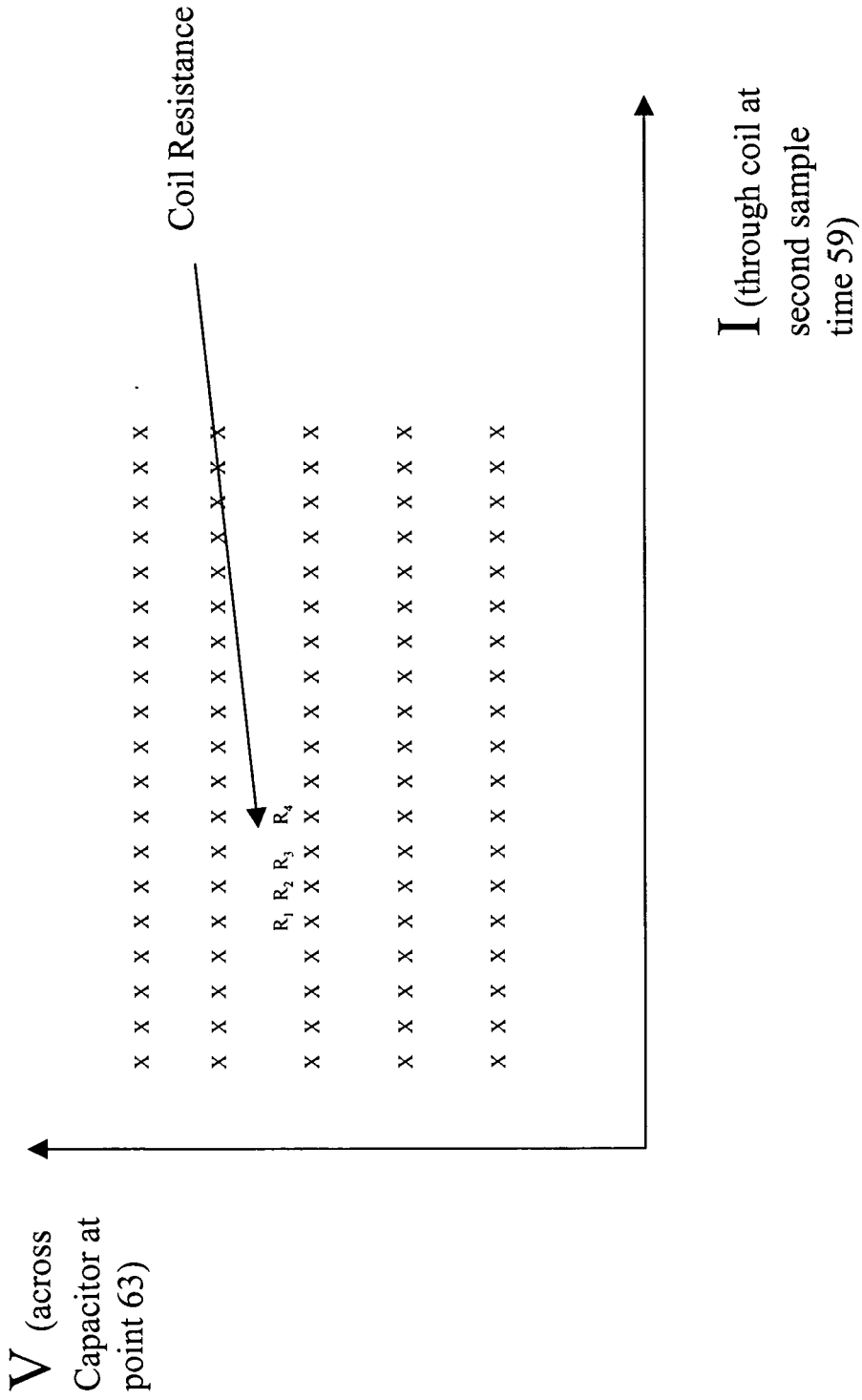

FIGURE 7

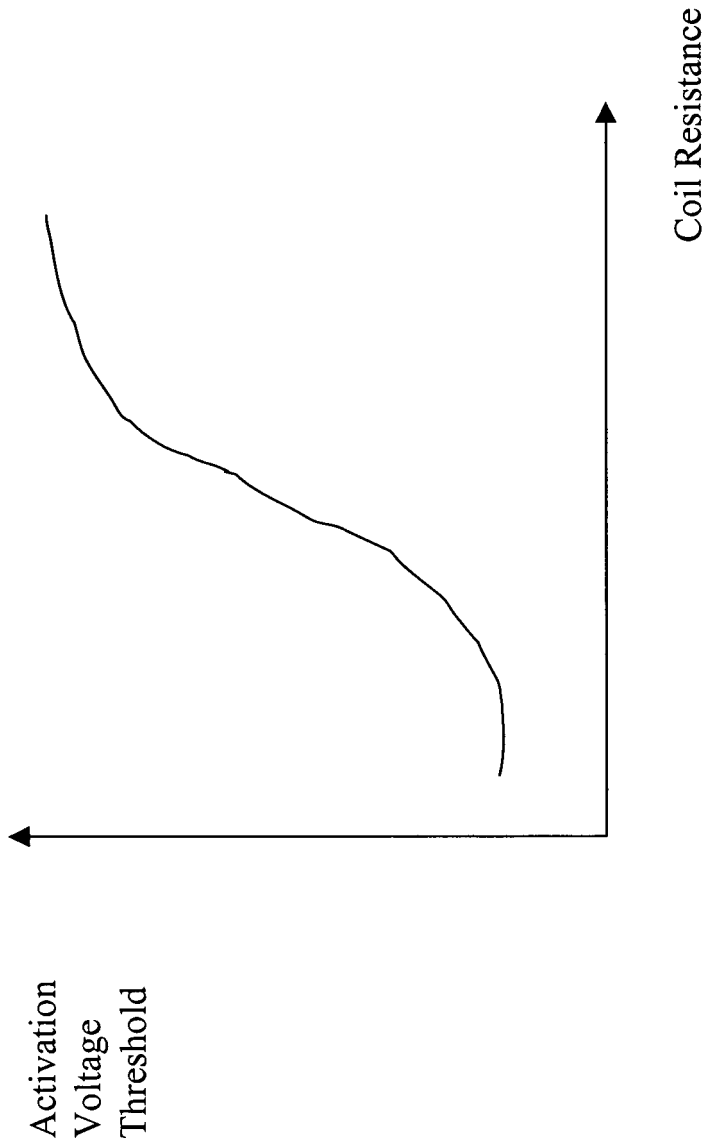

FIGURE 8

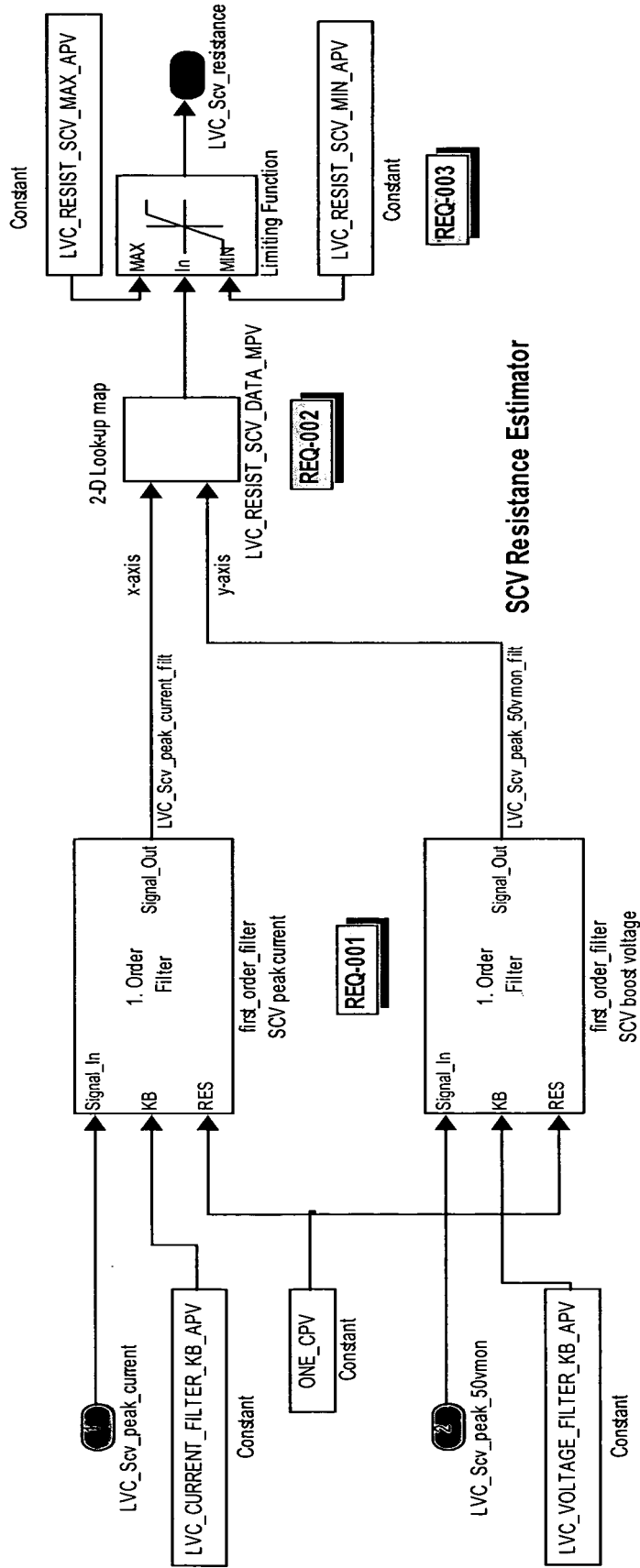

FIGURE 9

Boost Redrive Controller

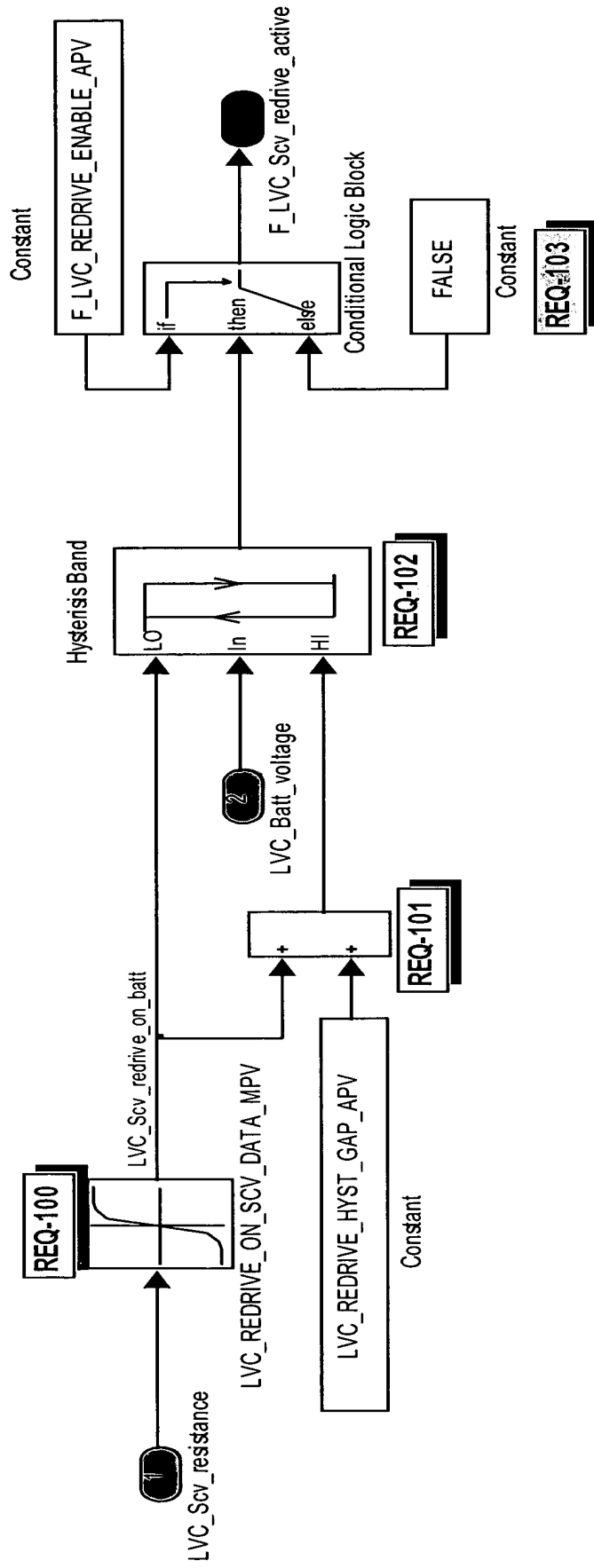

FIGURE 10

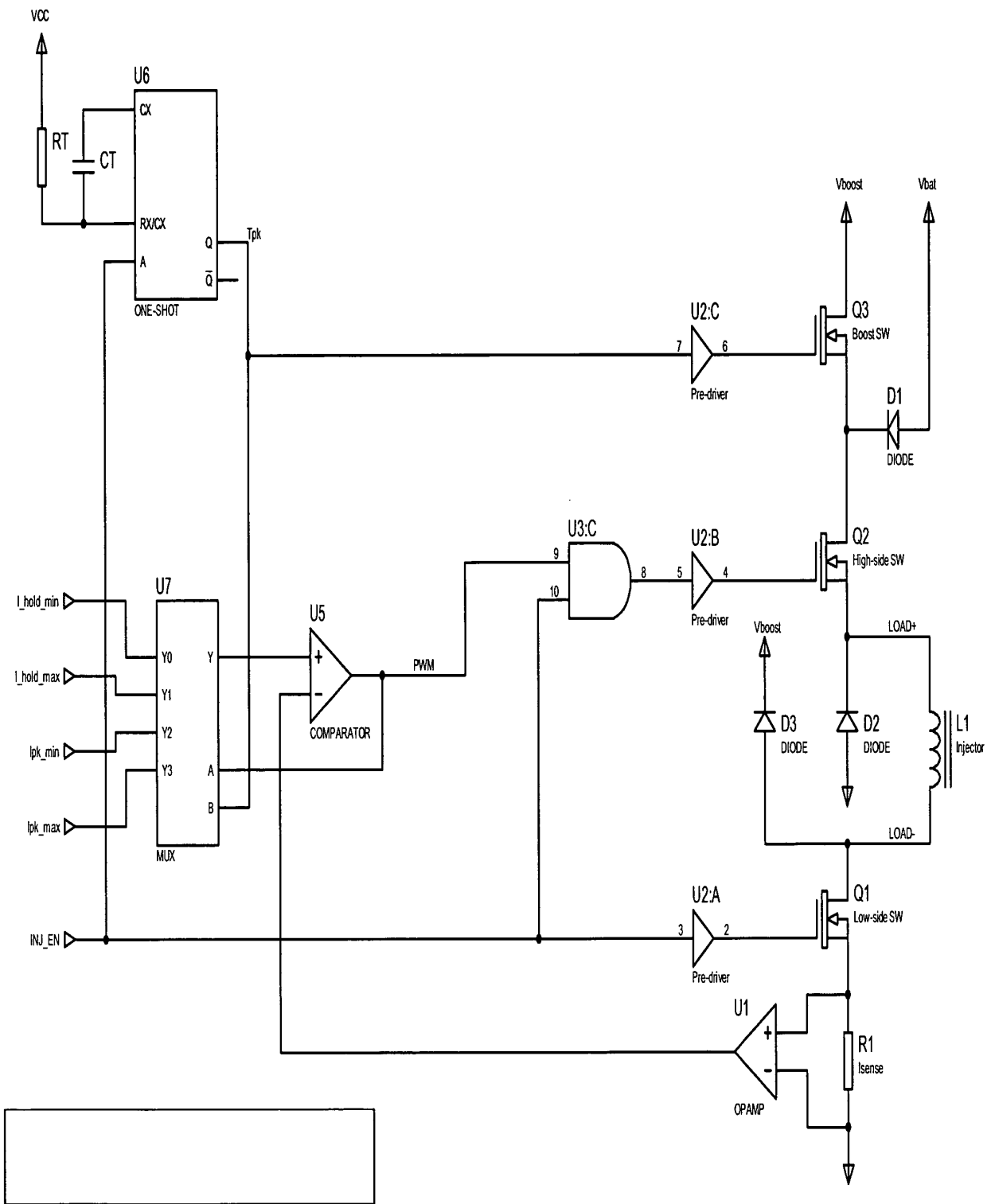

Figure 11

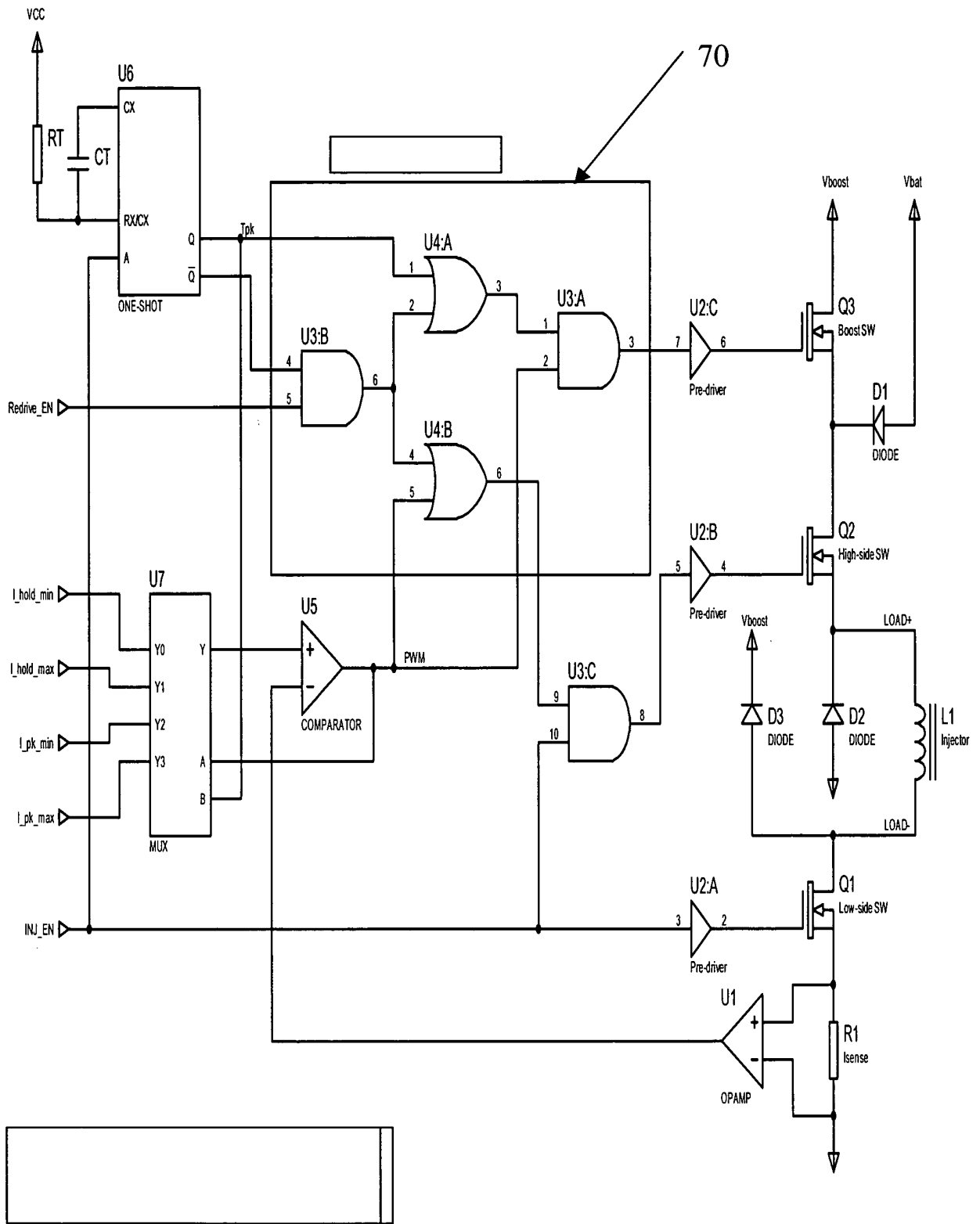

Figure 12

REFERENCES CITED IN THE DESCRIPTION

This list of references cited by the applicant is for the reader's convenience only. It does not form part of the European patent document. Even though great care has been taken in compiling the references, errors or omissions cannot be excluded and the EPO disclaims all liability in this regard.

Patent documents cited in the description

- US 2005047053 A [0015]