

PATENT DECLARATION FORM (CONVENTION)
COMMONWEALTH OF AUSTRALIA

Patents Act 1952

Regulation
12 (2)

DECLARATION IN SUPPORT OF A CONVENTION APPLICATION
FOR A PATENT

To be signed by the applicant(s) or in the case of a body corporate to be
signed by a person authorised by the body corporate.

In support of the Convention application made for a patent for an invention entitled

(a) Insert title
of invention.

(a) Current Transformer Arrangement for a Static Electricity
Meter

(b) Insert full
name(s) of
declarant(s).

~~I~~/We (b) Kurt Toniolo Hans Nünlist

(c) Insert
address(es) of
declarant(s).

of (c) Keltenweg 8 Rigistrasse 45
CH-6312 Steinhausen CH-6314 Unterägeri
Switzerland Switzerland

do solemnly and sincerely declare as follows:-

~~1. I am/We are the applicant(s) for the patent~~

(OR, IN THE CASE OF AN APPLICATION BY A BODY CORPORATE.)

1. ~~I~~/We are authorised by LGZ Landis & Gyr Zug AG

..... the applicant for the patent to make this declaration on its behalf.

2. The basic application(s) as defined by Section 141 of the Act was/were made in the following
country or countries on the following date(s) namely:-

(d) Insert
country in
which basic
application(s)
was/were
filed.

in (d) Germany on (e) 14 September 1985

(e) Insert date
of basic
application(s).

by (f) Richard Friedl

(f) Insert full
names of basic
applicant(s).

in (d) Germany on (e) 23 December 1985

by (f) Richard Friedl

in (d) Germany on (e) 10 June 1986

by (f) Richard Friedl

~~3. I am/We are the actual inventor(s) of the invention referred to in the basic application.~~

(OR, WHERE A PERSON OTHER THAN THE INVENTOR IS THE APPLICANT)

(g) Insert full
name(s) of
actual
inventor(s)

3. (g) Richard Friedl

(h) Insert
address(es) of
actual
inventor(s).

..... Tiergarten 67, D-3300 Braunschweig, Federal Republic of Germany...

of (h)

is/are the actual inventor(s) of the invention and the facts upon which the applicant(s) is/are entitled to
make the application are as follows:

(i) Set out how
applicant(s) title
derive(s) title
from actual
inventor(s)
i.e., assignee of
the invention
from the actual
inventor(s).

(i) The applicant is the assignee of the said invention from

..... the said inventor.....

4. The basic application(s) referred to in paragraph 2 of this Declaration was/were the first
application(s) made in a Convention country in respect of the invention the subject of the application.

Attestation or
legalisation
not required.

Declared at Zug this 16th day of March 1987

To:

LGZ LANDIS & GYR ZUG AG

The Commissioner of Patents

i.v. K-Toniolo / H. Nünlist

Signature of Declarant(s)

(12) PATENT ABRIDGMENT (11) Document No. AU-B-63393/86
(19) AUSTRALIAN PATENT OFFICE (10) Acceptance No. 592114

(54) Title
CURRENT TRANSFORMER FOR STATIC ELECTRICITY METER

International Patent Classification(s)
(51)⁴ **G01R 015/02 H01F 040/06**

(21) Application No. : **63393/86** (22) Application Date : **08.09.86**

(87) WIPO Number : **WO87/01812**

(30) Priority Data

(31) Number	(32) Date	(33) Country
3532911	14.09.85	DE FEDERAL REPUBLIC OF GERMANY
3545953	23.12.85	DE FEDERAL REPUBLIC OF GERMANY
3619423	10.06.86	DE FEDERAL REPUBLIC OF GERMANY

(43) Publication Date : **07.04.87**

(44) Publication Date of Accepted Application : **04.01.90**

(71) Applicant(s)
LGZ LANDIS & GYR ZUG A.G.

(72) Inventor(s)
RICHARD FRIEDL

(74) Attorney or Agent
ARTHUR S. CAVE & CO.

(56) Prior Art Documents
US 4626778

(57) Claim

1. A current transformer arrangement comprising a primary conductor for carrying alternating current to be measured and a secondary winding comprising at least two series-connected electrically identical secondary coils having an astatic configuration, the output voltage of the series-connected coils being applied to an electronic integration stage on the output side thereof to produce a measurement signal which is independent of frequency, wherein, so as to produce a maximum magnetic field strength, the primary conductor is formed into at least one current loop, the turns of at least one of the secondary coils are arranged for maximum magnetic coupling at a minimum spacing relative to the corresponding current loop and engage as completely as possible the magnetic flux produced by the current loop, and the magnetic coupling is effected without magnetic materials, the secondary coils extending in their axial direction over a minimum part of the length of the magnetic field lines produced by the current in the primary conductor, and wherein the secondary coils are arranged in closely adjacent juxtaposed relationship for optimum external field compensation.

PCT

WELTORGANISATION FÜR GEISTIGES EIGENTUM
Internationales Büro



INTERNATIONALE ANMELDUNG VERÖFFENTLICHT NACH DEM VERTRAG ÜBER DIE
INTERNATIONALE ZUSAMMENARBEIT AUF DEM GEBIET DES PATENTWESENS (PCT)

<p>(51) Internationale Patentklassifikation⁴ : G01R 15/02, H01F 40/06</p>	<p>A1</p>	<p>(11) Internationale Veröffentlichungsnummer: WO 87/ 01812 (43) Internationales Veröffentlichungsdatum: 26. März 1987 (26.03.87)</p>
<p>(21) Internationales Aktenzeichen: PCT/EP86/00515 (22) Internationales Anmeldedatum: 8. September 1986 (08.09.86) (31) Prioritätsaktenzeichen: P 35 32 911.4 P 35 45 953.0 P 36 19 423.9 (32) Prioritätsdaten: 14. September 1985 (14.09.85) 23. Dezember 1985 (23.12.85) 10. Juni 1986 (10.06.86) (33) Prioritätsland: DE (71) Anmelder (für alle Bestimmungsstaaten ausser US): LGZ LANDIS & GYR ZUG AG [CH/CH]; CH-6301 Zug (CH). (72) Erfinder; und (75) Erfinder/Anmelder (nur für US) : FRIEDL, Richard [DE/DE]; Tiergarten 67, D-3300 Braunschweig (DE).</p>	<p>(74) Anwälte: NÜNLIST, Hans usw.; LGZ Landis & Gyr Zug AG, Konzern-Patentabteilung, CH-6301 Zug (CH). (81) Bestimmungsstaaten: AT (europäisches Patent), AU, BE (europäisches Patent), CH (europäisches Patent), DE (europäisches Patent), DK, FI, FR (europäisches Patent), GB (europäisches Patent), IT (europäisches Patent), JP, LU (europäisches Patent), NL (europäi- sches Patent), NO, SE (europäisches Patent), US.</p> <p>Veröffentlicht <i>Mit internationalem Recherchenbericht. Vor Ablauf der für Änderungen der Ansprüche zugelas- senen Frist. Veröffentlichung wird wiederholt falls An- derungen eintreffen.</i></p> <p style="text-align: center;">A. O. J. P. 14 MAY 1987</p> <div style="border: 2px solid black; padding: 5px; width: fit-content; margin: auto;"> <p style="text-align: center;">AUSTRALIAN 7 APR 1987 PATENT OFFICE</p> </div>	

This document contains the amendments made under Section 49 and is correct for

(54) Title: CURRENT TRANSFORMER FOR A STATIC ELECTRICITY COUNTER

(54) Bezeichnung: STROMWANDLERANORDNUNG FÜR EINEN STATISCHEN ELEKTRIZITÄTSZÄHLER

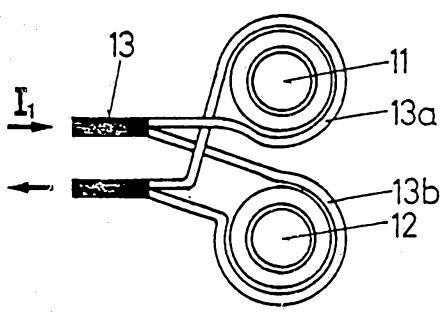

(57) Abstract

The current transformer arrangement on the secondary side with an integration stage is provided with a secondary winding consisting of two astatically designed coils (31, 32) lying next to one another and connected in series. As a result external parasitic magnetic fields have practically no effect on the transmission of the measured value. A large output signal from the secondary side is achieved by a large magnetic coupling of the primary conductor and secondary coil without the use of ferromagnetic materials. Preferably, the primary conductor (23) is designed as a flat conductor with suitably arranged slot-shaped recesses (25 to 28), so that primary windings (29a to 29g) are formed by changing the conductor cross-section (Fig. 5, 6, 7).

(57) Zusammenfassung

Die sekundärseitig mit einer Integrierstufe ausgerüstete Stromwandleranordnung ist mit einer Sekundärwicklung aus zwei astatisch aufgebauten nebeneinanderliegenden und in Reihe geschalteten Spulen (31, 32) versehen. Hierdurch sind äussere magnetische Störfelder praktisch ohne Einfluss auf die Messwertübertragung. Ein grosses sekundärseitiges Ausgangssignal wird durch eine grosse magnetische Kopplung des Primärleiters und der Sekundärspule ohne Verwendung von Ferromagnetika erreicht. Vorzugsweise ist der Primärleiter (23) als Flachleiter mit geeignet angeordneten schlitzförmigen Ausnehmungen (25 bis 28) ausgebildet, so dass durch Veränderung der Leiterquerschnitte primäre Windungen (29a bis 29g) gebildet werden (Fig. 5, 6, 7).

CURRENT TRANSFORMER ARRANGEMENT

This invention relates to a current transformer arrangement.

Measuring large currents for determining energy consumption by
5 means of static electricity meters requires the use of current
transformers whose output signals must be suitable for further
processing in electronic measuring assemblies. The currents to be
measured may amount to over 100 amps which must be detected down into
10 the measuring range of milliamps, with low levels of deviation from
linearity. Such arrangements must be substantially insensitive in
relation to direct current components in the current to be measured.
In addition, the consumption of necessary auxiliary energy for
operating the arrangement must be as low as possible.

Furthermore, the requirements set forth in the IEC Publication
15 521 must be met, in particular galvanic separation with a high level of
insulation strength, ability to withstand short-circuiting,
insensitivity in relation to external magnetic interference fields and
the suppression of frequency effects.

The arrangement disclosed in German AS No 10 79 192, in the form
20 of a magnetic voltmeter, comprises two series-connected secondary coils
which surround a bus bar. The secondary sub-windings are short-
circuited at their ends by magnetic material. That provides a closed
magnetic circuit (known as a Rogowski coil) which behaves astatically
in relation to extraneous fields if the density of turns of the sub-
25 windings is sufficiently high and the distribution of turns is uniform.
With high levels of current density in the primary conductor, the
secondary coils must be at a certain spacing therefrom in order to
ensure satisfactory integration of the sub-voltages of the irregularly
distributed winding.

30 The known current transformer arrangement is provided with an
electronic integrating stage whose frequency response, which is
inversely proportional in respect of its input signal to the output
signal, compensates for the proportional frequency dependency of the
voltage induced in the secondary winding by the current to be measured,
and which further rotates the input signal with respect to the opposite
35 phase position of its output signal, through a phase angle of 90° ,
relative to the current to be measured. The measuring signal at the



output of the integrating stage is independent of the measuring frequency and is in phase opposition to the current to be measured, with direct proportionality between the amplitudes.

5 A disadvantage of the known current transformer arrangement is that the requirement for substantial insensitivity in relation to external magnetic interference fields is not completely met by the use of ferromagnetic materials. Furthermore, the known arrangement delivers very weak output signals as there is only very slight coupling between the fields of the primary conductor and the secondary coils.
10 That means that that process is not suitable for measuring current strengths of less than about 1 kiloamp.

According to the present invention there is provided a current transformer arrangement comprising a primary conductor for carrying alternating current to be measured and a secondary winding comprising
15 at least two series-connected electrically identical secondary coils having an astatic configuration, the output voltage of the series-connected coils being applied to an electronic integration stage on the output side thereof to produce a measurement signal which is independent of frequency, wherein, so as to produce a maximum magnetic
20 field strength, the primary conductor is formed into at least one current loop, the turns of at least one of the secondary coils are arranged for maximum magnetic coupling at a minimum spacing relative to the corresponding current loop and engage as completely as possible the magnetic flux produced by the current loop, and the magnetic coupling
25 is effected without magnetic materials, the secondary coils extending in their axial direction over a minimum part of the length of the magnetic field lines produced by the current in the primary conductor, and wherein the secondary coils are arranged in closely adjacent juxtaposed relationship for optimum external field compensation.

30 Embodiments of the present invention provide insensitivity to external magnetic interference fields as well as a high secondary-side output signal, combined with a compact design and the simultaneous use of inexpensive components.

35 In the preferred embodiment, the coil carrier has a degree of permeability which is substantially independent of the magnetic field of the primary conductor. The secondary winding comprises two series-connected coils whose axes extend parallel to each other. The



direction of winding of the coils corresponds to that of a solenoid which is spatially buckled in the centre through 180° . That astatic arrangement of the coils results in a secondary winding which is independent of external homogenous magnetic alternating interference fields as the partial voltages induced by the interference fields in the two coils cancel each other out. While in the known coils consisting of sub-windings, the sub-windings are always brought together to provide a closed integration path corresponding to a Rogowski coil, in the case of embodiments of the present invention the secondary coils, in order to attain small dimensions, each extend only over a part of the length of less than 50% of the magnetic field lines generated by the current in the primary conductor so that no closed integration path is formed. In that arrangement the second secondary coil serves primarily to compensate for the influence of external fields. In regard to achieving the best possible compensation effect, the two secondary coils are of small spatial dimensions and are arranged as closely together as possible.

The secondary coils may be in the form of cylindrical or flat coils having mutually parallel axes, wherein at least one of the two coils is disposed in three-dimensional terms at a location at which the primary current produces the maximum possible field strength. The high field strength required for a high secondary-side output signal of the arrangement is produced by shaping of the primary conductor in the form of a loop. In that way the secondary sub-coils only pick up the magnetic field of the primary conductor locally in a punctiform manner, wherein the sum of the voltages induced in the two secondary coils is proportional to the primary current to be detected.

A particular feature of the current transformer arrangement embodying the invention is the high magnetic coupling thereof between the primary conductor and the secondary coil, thereby producing high secondary-side output signals which permit the arrangement to be used for linear detection of currents with current strengths of down to a few milliamps, and this is achieved without using ferromagnetic material. This provides a spatially compact design which permits inexpensive manufacture.



In a preferred embodiment, the primary conductor which is in the form of a loop surrounds the secondary coil in the peripheral direction thereof as closely and as completely as possible. As in that arrangement the secondary coil is arranged within a primary conductor which is in
 5 the form of an eye, that design provides for optimum magnetic coupling with correspondingly high output signals.

In an advantageous embodiment, the primary conductor encloses both secondary coils with two series-connected windings. It is also possible however for the primary conductor to comprise conductor
 10 portions which are connected in parallel relationship with each other and the windings of which each enclose one of the coils. In that case, the primary current to be measured is distributed to the two windings so that, in the case of a primary conductor which is preferably stamped out of copper, of rectangular cross-section, it is possible to avoid
 15 folds where the conductor portions cross over.

A highly advantageous embodiment is characterised by the features of claim 5. In that case the primary conductor which is in the form of a flat conductor is folded about a transverse axis through an angle of 180° so that the out and return conductors are disposed
 20 at a small spacing one above the other; that spacing may be of such a nature, at least in a portion-wise manner, that the resulting space is suitable for accommodating the secondary winding. In that embodiment the influence of the magnetic interference field on the measurement result is practically eliminated, even without magnetic
 25 materials. The shape and the small dimensions of the arrangement easily permit fully automatic production.

It is advantageous if the recesses extend substantially from the centre line to the edge of the primary conductor, in mutually opposite relationship. In that way the electrical current which flows in the
 30 longitudinal direction of the flat primary conductor is deflected to the middle of the primary conductor so that the current paths



are formed into a loop.

Another embodiment provides that the mutually oppositely disposed portions of the primary conductor each comprise two mutually oppositely directed recesses which are arranged in parallel offset relationship, 5 thereby forming two windings which are disposed in juxtaposed relationship in the longitudinal direction of the primary conductor, wherein the magnetic flux of each winding passes substantially through a respective coil of the secondary winding. In that arrangement the coils of the secondary winding are advantageously disposed between the portions of 10 the primary conductor. As the configuration of the primary conductor results in two juxtaposed windings, the axes of which are respectively formed by the mutually facing ends of the recesses, each coil of the secondary winding may be associated with a respective primary winding, thus providing for optimum flux linkage.

Another advantageous embodiment is provided if the coils of the secondary winding, in a planar technology design, are disposed in one or more layers, possibly also on both sides in the form of spirals, on a substrate. The plate-like substrate may be inserted between the spaced-apart conductor portions. The substrate with the two coils 20 of the secondary winding may also be arranged outside the space between the conductor portions above the effective winding areas of the primary conductor.

It is also possible for the substrate to include further electronic components of the electricity meter. They may be for example the 25 electronic components of the integrating stage and the multiplier stage.

A further embodiment provides that the one conductor portion has two mutually oppositely directed recesses which extend to the edge of the primary conductor on a common longitudinal axis, while arranged in parallel therewith is a central recess on the other conductor 30 portion. With that arrangement of the recesses, the current paths are such as to form two turns which are connected in parallel and each



of which is linked with the magnetic flux of a coil of the secondary winding.

The invention will be described in greater detail hereinafter by means of embodiments illustrated in the drawing. The known integration
5 circuit has not been illustrated therein.

In the drawing:

Figure 1 is a front view of two secondary coils of astatic design, one of which is enclosed by a primary conductor,

Figure 2 is a front view of two coils of astatic design, which
10 are enclosed by series-connected turns of the primary conductor,

Figure 3 shows an arrangement of the secondary coils in Figure 2 but with turns of the primary conductor connected in parallel,

Figure 4 is a perspective view of a primary conductor in the form of a flat conductor, in which one of the secondary coils of an
15 astatic design is arranged between oppositely disposed portions of the flat conductor and the other secondary coil is arranged outside the flat conductor,

Figure 5 is a perspective view of a primary conductor in an embodiment which has been modified in comparison with Figure 4,

Figure 6 is a perspective view of the coils, of astatic design,
20 of the secondary winding, with a base plate which can be inserted into the primary conductor shown in Figure 5,

Figure 7 is a view in cross-section of the arrangement of Figures 5 and 6 in the operative condition, on a reduced scale,

Figure 8 is a perspective view of an embodiment of the primary conductor which is modified in comparison with Figures 4 and 5,

Figure 9 is a perspective view of flat coils of an astatic design, in the form of a secondary winding on a base plate which can be inserted into the primary conductor shown in Figure 8,

Figure 10 is a perspective view of a primary conductor comparable
30 to that shown in Figure 8, with coils of the secondary winding arranged therein,



Figure 11 is a plan view of a folded-open primary conductor in the form of a flat conductor,

Figure 12 is a plan view of the primary conductor shown in Figure 11 in the folded condition,

5 Figure 13 is a plan view of a base plate with flat coils of an astatic design, of a configuration comparable to Figure 9,

Figure 14 is a plan view of the folded primary conductor shown in Figure 11, on the opposite side in comparison with Figure 12, and

10 Figure 15 is a view in cross-section of the arrangement shown in Figure 14.

Figure 1 shows two spaced-apart cylindrical coils 1 and 2, which are of an astatic design, of a secondary winding 3. The coils 1 and 2 which are held by means of a spacer 4 are geometrically and electrically identical and extend with their cylinder axes parallel to each other. The coils 1 and 2 are arranged in an insulating cylinder 5 and 6. The coil 1 is enclosed by a turn 7a of the primary conductor 7 through which the current I_1 to be measured flows in the direction of the indicated arrows. The voltages induced in the coils 1 and 2 by the magnetic field of the alternating current flowing in the primary conductor 7 are added to produce a signal which is proportional to the alternating current I_1 to be measured. Voltages induced by homogeneous external interference alternating fields have different signs by virtue of the astatic arrangement of the coils 1 and 2, and cancel each other out in the sum. That arrangement substantially eliminates the influence of external magnetic alternating fields on correct operation of the current transformer arrangement. The influence of external fields may be further reduced by magnetic screening material surrounding the coils.

In Figure 2 the coils 8 and 9 correspond to those shown in Figure 1. The secondary coils 8 and 9 are successively surrounded by the common primary conductor 10. That series connection of the primary turns 10a and 10b results in a measuring signal which is



increased in comparison with the arrangement shown in Figure 1.

In Figure 3 the coils 11 and 12 correspond to the coils 8 and 9 in Figure 2. The primary conductor 13 is branched out to provide two conductor portions which are each formed into a respective turn 13a and 13b embracing the respective coils 11 and 12. The current I_1 is branched on to the conductor portions with the turns 13a and 13b, the sum of the voltages induced in the coils 11 and 12 being proportional to the current I_1 to be measured. In comparison with the arrangement shown in Figure 2, the arrangement shown in Figure 3 has the advantage that, with the primary conductor 13 which is preferably stamped out of copper and which is of rectangular cross-section (flat conductor), it is possible to avoid folds at the location at which the conductor portions cross over.

In the embodiment shown in Figure 4, a primary conductor 14 is in the form of a flat conductor of rectangular cross-section and which is so folded that mutually oppositely disposed conductor portions 14a and 14b produce a square or rectangular cavity 15. Outside the cavity 15, oppositely disposed portions of the primary conductor 14 are separated from each other by an insulating layer 16. The conductor portion 14a is provided with a slot-like recess 17 which extends from approximately the middle to the edge. A recess 18 which extends in the opposite direction to the edge is provided on the oppositely disposed conductor portion 14b. The recesses 17 and 18 influence the geometrical position of the current paths of the current which is to be measured, as represented by the arrows 19 and 20, in such a manner that a turn is formed for the primary current. The secondary coil 21 which is shown in broken lines is arranged in the magnetic field of that turn. A second secondary coil 22 is disposed outside the primary conductor, to compensate for external magnetic fields.

The primary conductor 23 shown in Figure 5 differs from the embodiment in Figure 4 in that two oppositely directed slot-like



recesses 24, 25 and 26, 27 respectively are provided in the mutually oppositely disposed conductor portions 23a and 23b. Each of the laterally open recesses 24 to 27 extends approximately to the middle of the conductor portions 23a and 23b. The recesses 24 and 26
 5 are disposed in the same plane perpendicularly to the primary conductor 23 when it is folded through 180° in the operative condition, that is to say the conductor portions 23a and 23b extend parallel to each other. In the same manner, the recesses 25 and 27 are arranged in a common plane perpendicularly to the primary conductor 23.

10 By virtue of the above-indicated configuration of the recesses 24 to 27 the primary current flows along current paths which are indicated by the arrows 29a to 29g. As a result, series-connected primary turns are formed in the planes of the conductor portions 23a and 23b, and secondary coils may be arranged in the magnetic field
 15 of the primary turns.

Disposed on the base plate 30 shown in Figure 6 are two astatically arranged secondary coils 31 and 32. In the operative condition, the base plate 30 is located with the coils 31 and 32 between the conductor portions 23a and 23b of the primary conductor
 20 as shown in Figure 5. The position of the coil 31 in Figure 6 is indicated on the conductor portion 23b in Figure 5 by the broken-line circle 33. The coil 32 is disposed in a corresponding manner in Figure 6, in a region represented by the broken-line circle 60 in Figure 5.

25 Figure 7 shows the current transformer arrangement with the primary-side part shown in Figure 5 and the secondary-side part shown in Figure 6, in the operative condition. In this case, the upper and lower portions of the primary conductor 23 are separated from each other by an insulating layer 61.

30 The primary conductor 34 in Figure 8 is comparable to the primary conductor 23 in Figure 5. Only the spacing between the upper conductor portion 34a and the lower conductor portion 34b is smaller



and corresponds to the thickness of the insulating layer 35.

The base plate 36 shown in Figure 9 with the secondary coils 38 and 39 arranged thereon is disposed in the operative condition of the current transformer arrangement between the conductor portions 34a and 34b of the primary conductor 34 shown in Figure 8. The coils 38 and 39 in Figure 9 are of a spiral configuration and are produced by planar technology so that the small space between the conductor portions 34a and 34b as shown in Figure 8 is adequate. In the operative condition the centre point of the coil 38 is disposed approximately at the middle end of the slot-like recess 40 in Figure 8. In a corresponding fashion, the central point of the coil 39 and the middle end of the recess 41 are arranged in approximately coincident positions.

Figure 10 shows a primary conductor 42 which substantially corresponds to the primary conductor 34 in Figure 8. However the recesses 44 and 45 are in the form of holes at their ends which are directed towards the middle of the primary conductor 42, while secondary coils 46 and 47 of an astatic design are mounted in the holes.

In the embodiment shown in Figure 11 a primary conductor 48 is shown in an open condition, that is to say before being folded about a line 49. In the folded condition a conductor portion 48a is disposed above a conductor portion 48b. The conductor portion 48b has recesses 50 and 51 which extend in mutually opposite relationship and on a common longitudinal axis parallel to the fold line 49. Provided on the conductor portion 48a is a recess 52 which extends only in the middle region of the conductor portion 48 and which is at the same spacing from the fold line 49 as the recesses 50 and 51. The locations of the secondary coils are illustrated by the broken-line circles 53 and 54. Arranged in mirror image relationship with respect thereto, in relation to the fold line 49, are the corresponding base areas 55 and 56 for the secondary coils.



Figure 12 shows the primary conductor 48 of Figure 11 in the folded-together condition, so that the conductor portions 48a and 48b are disposed one above the other. Correspondingly only the recesses 50 and 51 are illustrated, with the locations for the secondary 5 coils, as indicated by the circles 53 and 54.

Figure 13 shows the secondary coils 56 and 57 of astatic design, which are fixed to a base plate 55. That arrangement which corresponds in principle to that shown in Figure 9 differs therefrom essentially in that the coils 56 and 57 are at the same spacing from the fold line 49 in Figure 13. The coils 56 and 57 may also be produced by a 10 planar technology. In order for both coils to be exposed to the corresponding primary magnetic flux, they may also be arranged outside the space between the folded conductor portions 48a and 48b in Figure 11, if the magnetic coupling involved is sufficient for a high output 15 signal. In that case also, the circles shown in Figures 11 and 12 are the corresponding locations for the secondary coils.

Figure 14 shows the primary conductor 48 in Figure 11 in the folded-together condition, from the opposite side in comparison with Figure 12. Accordingly only the middle recess 52 can be seen.

20 In Figure 15 also, the primary conductor 48 is shown in the folded-together condition, the spacing between the upper conductor portion 48a and the lower conductor portion 48b being determined by an insulating layer 57. The direction of the primary current to be measured is identified by the arrows 58 and 59. The base plate 55 25 of Figure 13 is inserted into the space 50.



THE CLAIMS DEFINING THE INVENTION ARE AS FOLLOWS:

1. A current transformer arrangement comprising a primary conductor for carrying alternating current to be measured and a secondary winding
5 comprising at least two series-connected electrically identical secondary coils having an astatic configuration, the output voltage of the series-connected coils being applied to an electronic integration stage on the output side thereof to produce a measurement signal which is independent of frequency, wherein, so as to produce a maximum
10 magnetic field strength, the primary conductor is formed into at least one current loop, the turns of at least one of the secondary coils are arranged for maximum magnetic coupling at a minimum spacing relative to the corresponding current loop and engage as completely as possible the magnetic flux produced by the current loop, and the magnetic coupling
15 is effected without magnetic materials, the secondary coils extending in their axial direction over a minimum part of the length of the magnetic field lines produced by the current in the primary conductor, and wherein the secondary coils are arranged in closely adjacent juxtaposed relationship for optimum external field compensation.
- 20 2. A current transformer arrangement according to claim 1, wherein the current loop closely embraces the at least one secondary coil in the peripheral direction thereof.
- 25 3. A current transformer arrangement according to claim 1 or claim 2, wherein two current loops are connected in series and each current loop embraces a secondary coil.
- 30 4. A current transformer arrangement according to claim 1 or claim 2, wherein two current loops are connected in parallel with each other and each current loop embraces a secondary coil.
- 35 5. A current transformer arrangement according to any one of the preceding claims, wherein the primary conductor is in the form of a folded flat conductor with mutually oppositely disposed conductor portions which, by means of at least one opening, each form at least one portion of the current loop in the plane of the flat conductor.
- 

6. A current transformer arrangement according to claim 5, wherein the openings extend in mutually opposite directions approximately from the centre line to the edge of the flat conductor.

5

7. A current transformer arrangement according to claim 6, wherein the oppositely disposed conductor portions of the flat conductor each have two mutually oppositely directed openings which are arranged in parallel displaced relationship and thereby form two portions of the current loop which portions are disposed side-by-side in the longitudinal direction of the flat conductor.

10

8. A current transformer arrangement according to any one of claims 5 to 7, wherein the secondary coils are arranged between the conductor portions of the flat conductor.

15

9. A current transformer arrangement according to claim 7 or claim 8, wherein the secondary coils are produced by a planar technique and are disposed in one or more layers in the form of spirals on a substrate.

20

10. A current transformer arrangement according to claim 5, claim 8 or claim 9, wherein the one conductor portion has two mutually oppositely directed openings which extend to the edge of the flat conductor on a common axis and arranged in parallel therewith on the other conductor portion is an opening which does not extend to the edges.

25

11. A current transformer arrangement substantially as herein described with reference to any of Figures 1 to 5, or Figures 5, 6 and 7, or Figure 8, of Figures 8 and 9, or Figure 10, or Figures 11 to 15 of the accompanying drawings.

30

12. A static electricity meter including a current transformer arrangement according to any one of the preceding claims.

35

DATED this 16th day of October, 1989.

LGZ LANDIS & GYR ZUG AG
By Its Patent Attorneys
ARTHUR S CAVE & CO

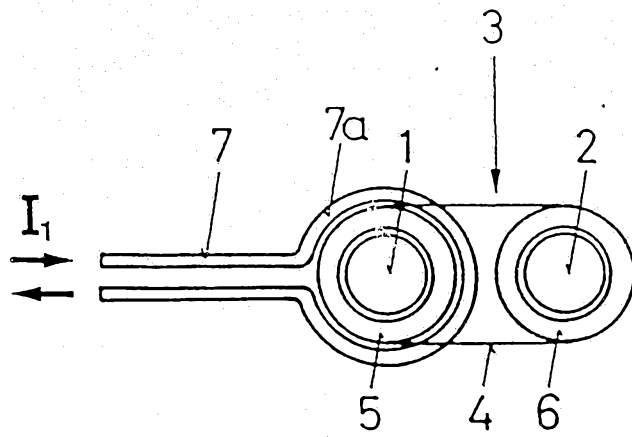

Fig.1

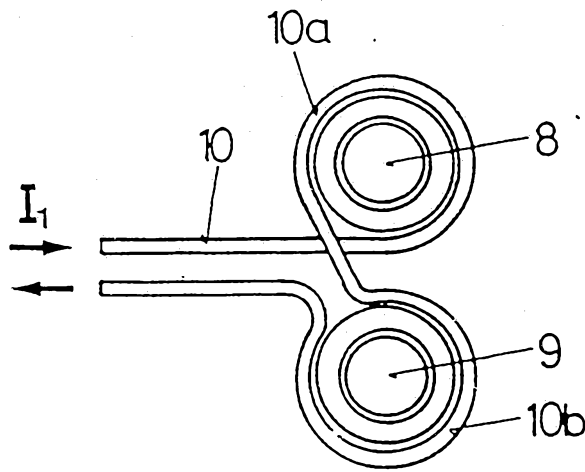

Fig.2

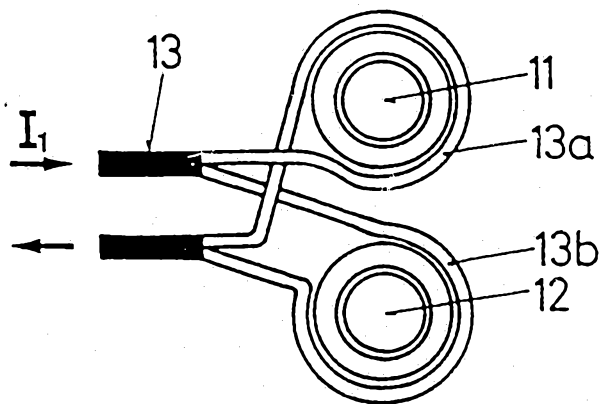
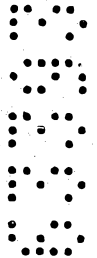

Fig.3



17 10 00 03303

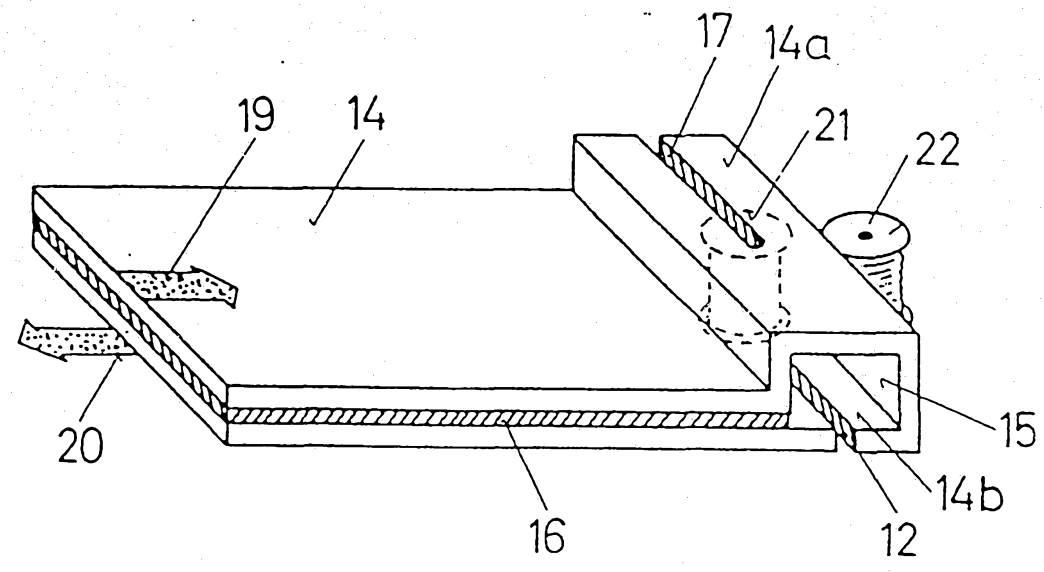

Fig.4

17 10 89

07393

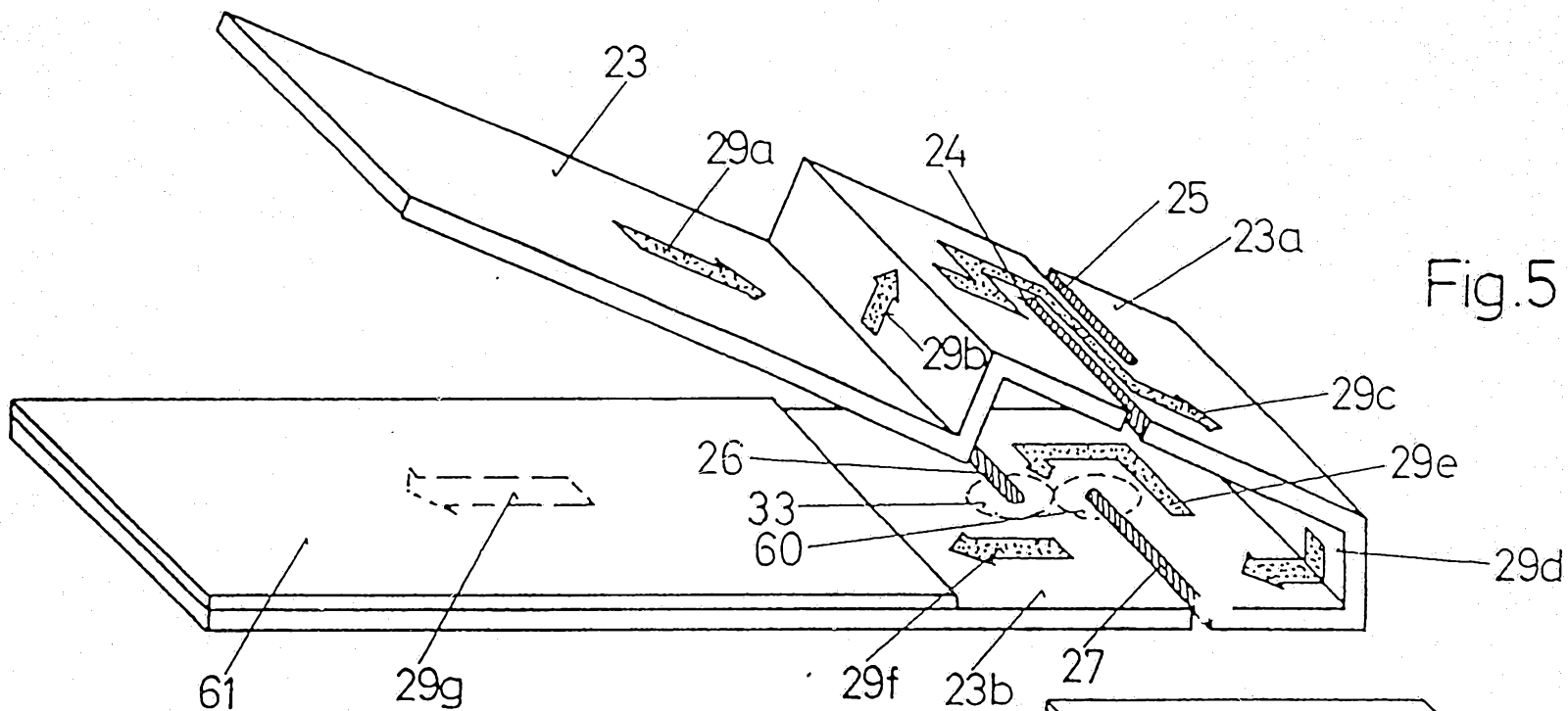

Fig. 5

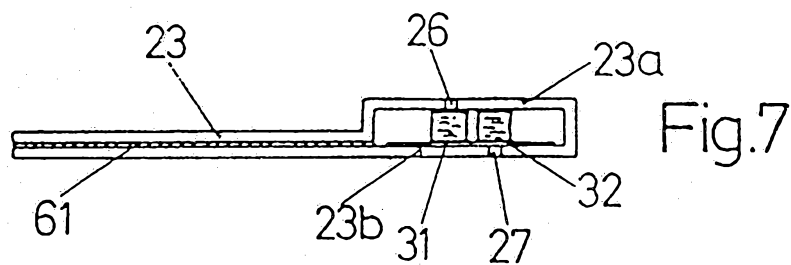

Fig. 7

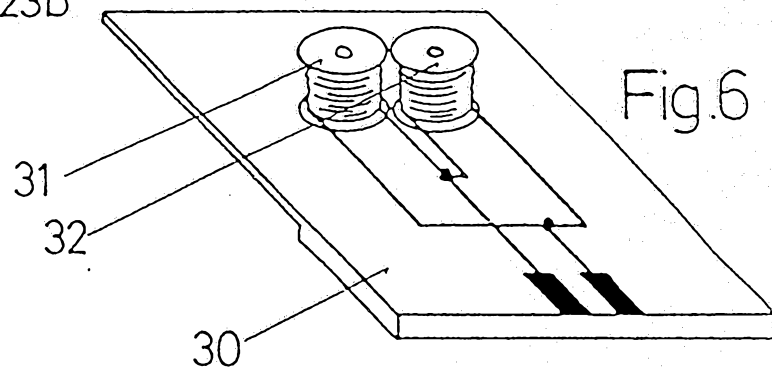

Fig. 6

17 10 09

63393

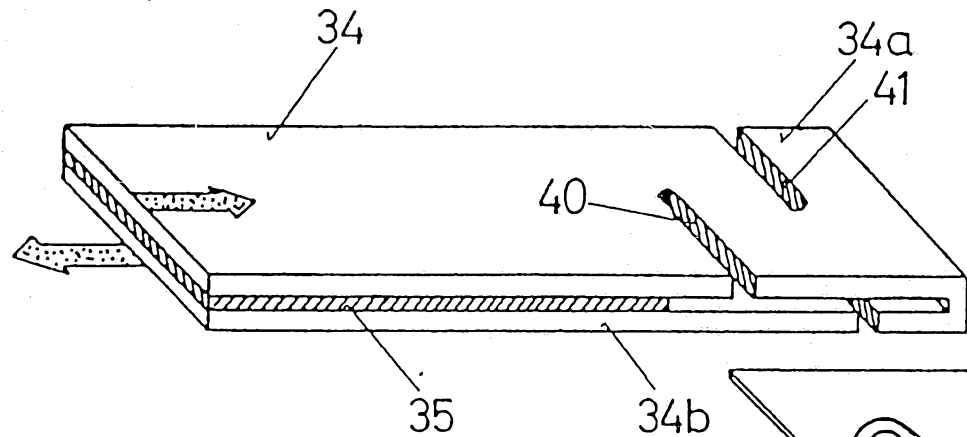

Fig. 8

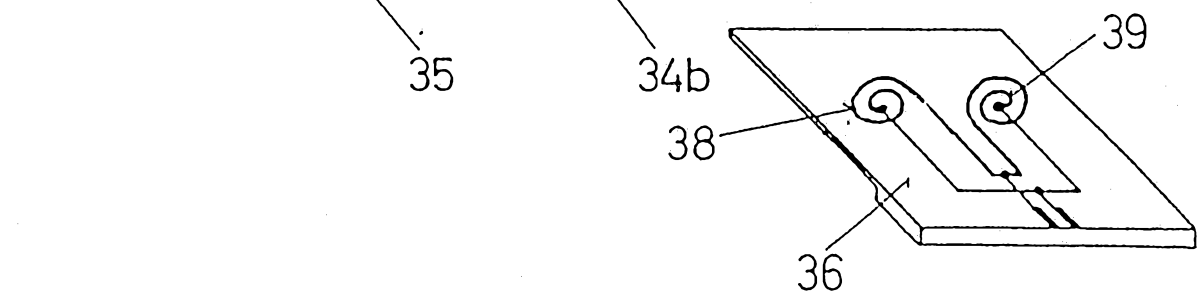

Fig. 9

17 10 00

03303

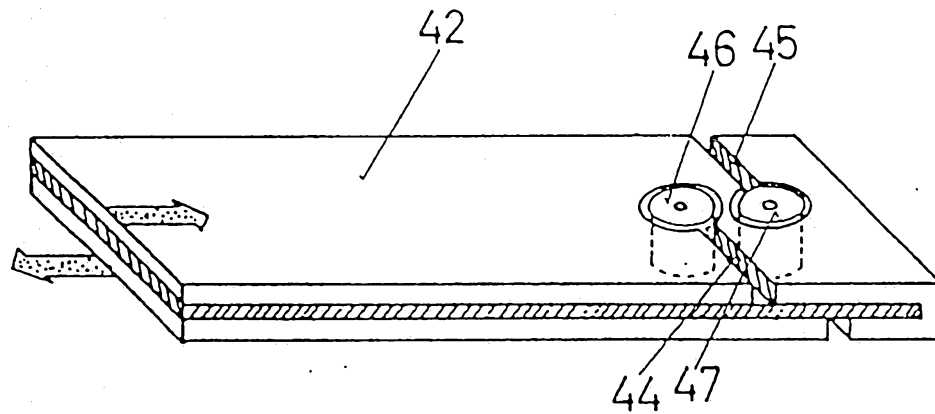

Fig.10

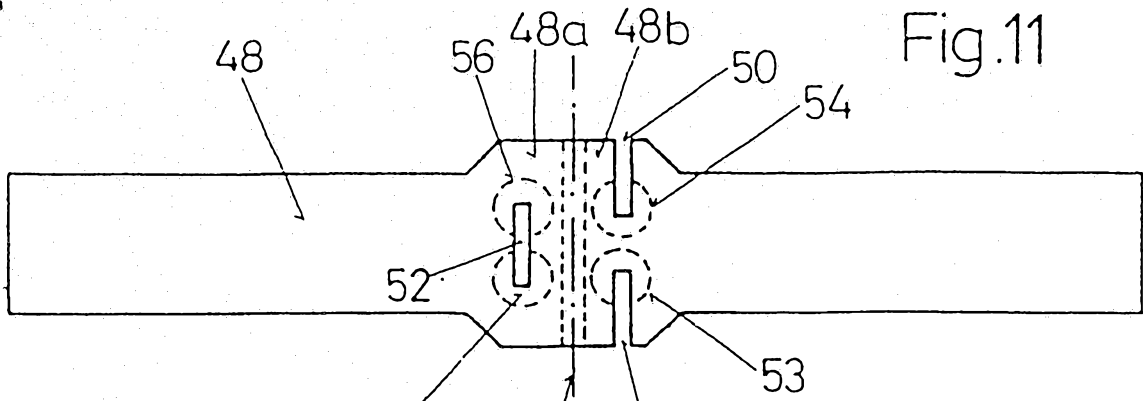

Fig.11

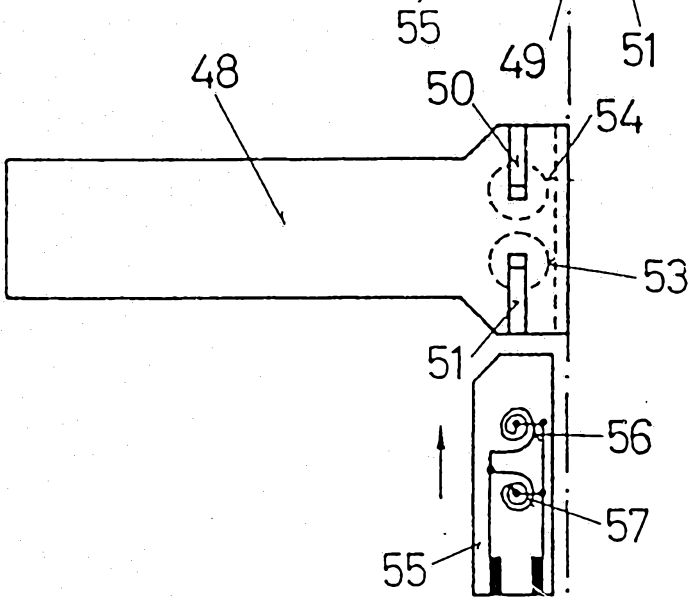

Fig.12

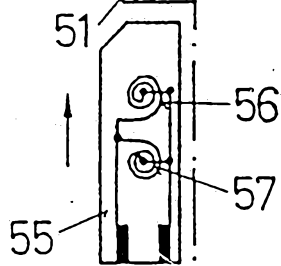

Fig.13

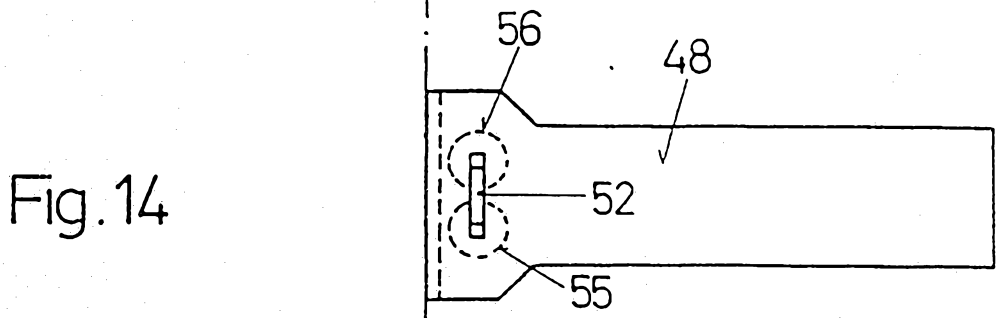

Fig.14

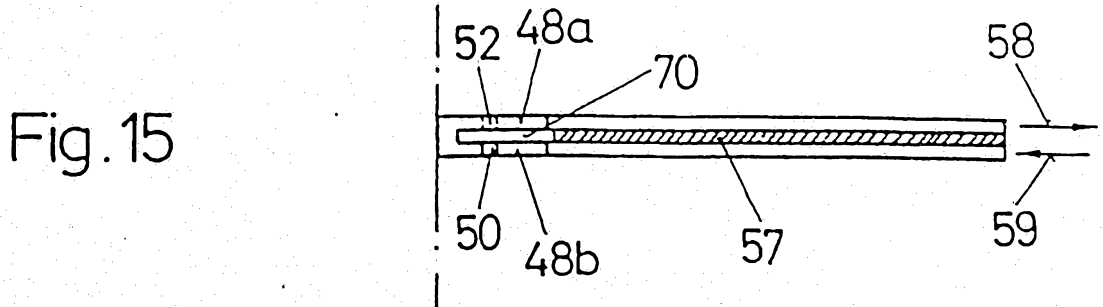

Fig.15

INTERNATIONAL SEARCH REPORT

International Application No PCT/EP 86/00515

I. CLASSIFICATION OF SUBJECT MATTER (If several classification symbols apply, indicate all) ⁶		
According to International Patent Classification (IPC) or to both National Classification and IPC		
Int.Cl. ⁴ G 01 R 15/02; H 01 F 40/06		
II. FIELDS SEARCHED		
Minimum Documentation Searched ⁷		
Classification System	Classification Symbols	
Int.Cl. ⁴	G 01 R; H 01 F	
Documentation Searched other than Minimum Documentation to the Extent that such Documents are Included in the Fields Searched ⁸		
III. DOCUMENTS CONSIDERED TO BE RELEVANT ⁹		
Category ¹⁰	Citation of Document, ¹¹ with indication, where appropriate, of the relevant passages ¹²	Relevant to Claim No. ¹³
A	WO, A, 83/01535 (R.FRIEDL) 28 April 1983 -----	
A	DE, B, 1079192 (LICENTIA) 7 April 1960 (cited in the application) -----	
A	DE, B, 1133817 (LICENTIA) 26 July 1962 -----	
<p>¹⁰ Special categories of cited documents:</p> <p>"A" document defining the general state of the art which is not considered to be of particular relevance</p> <p>"E" earlier document but published on or after the international filing date</p> <p>"L" document which may throw doubts on priority claim(s) or which is cited to establish the publication date of another citation or other special reason (as specified)</p> <p>"O" document referring to an oral disclosure, use, exhibition or other means</p> <p>"P" document published prior to the international filing date but later than the priority date claimed</p> <p>"T" later document published after the international filing date or priority date and not in conflict with the application but cited to understand the principle or theory underlying the invention</p> <p>"X" document of particular relevance; the claimed invention cannot be considered novel or cannot be considered to involve an inventive step</p> <p>"Y" document of particular relevance; the claimed invention cannot be considered to involve an inventive step when the document is combined with one or more other such documents, such combination being obvious to a person skilled in the art.</p> <p>"&" document member of the same patent family</p>		
IV. CERTIFICATION		
Date of the Actual Completion of the International Search	Date of Mailing of this International Search Report	
2 December 1986 (02.12.86)	21 January 1987 (21.01.87)	
International Searching Authority European Patent Office	Signature of Authorized Officer	

ANNEX TO THE INTERNATIONAL SEARCH REPORT ON

INTERNATIONAL APPLICATION NO. PCT/EP 86/00515 (SA 14443)

This Annex lists the patent family members relating to the patent documents cited in the above-mentioned international search report. The members are as contained in the European Patent Office EDP file on 11/12/86

The European Patent Office is in no way liable for these particulars which are merely given for the purpose of information.

Patent document cited in search report	Publication date	Patent family member(s)	Publication date
WO-A- 8301535	28/04/83	DE-A- 3140544	21/04/83
		GB-A,B 2118372	26/10/83
		EP-A,B 0093727	16/11/83
DE-B- 1079192		None	
DE-B- 1133817		None	

For more details about this annex :
see Official Journal of the European Patent Office, No. 12/82

INTERNATIONALER RECHERCHENBERICHT

Internationales Aktenzeichen PCT/EP 86/00515

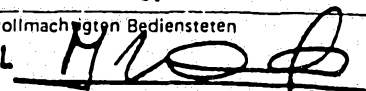
I. KLASSIFIKATION DES ANMELDUNGSGEGENSTANDS (bei mehreren Klassifikationssymbolen sind alle anzugeben) ⁶		
Nach der Internationalen Patentklassifikation (IPC) oder nach der nationalen Klassifikation und der IPC		
Int. Cl. ⁴ G 01 R 15/02; H 01 F 40/06		
II. RECHERCHIERTE SACHGEBIETE		
Recherchierter Mindestprüfstoff ⁷		
Klassifikationssystem	Klassifikationssymbole	
Int. Cl. ⁴	G 01 R; H 01 F	
Recherchierte nicht zum Mindestprüfstoff gehörende Veröffentlichungen, soweit diese unter die recherchierten Sachgebiete fallen ⁸		
III. EINSCHLÄGIGE VERÖFFENTLICHUNGEN⁹		
Art*	Kennzeichnung der Veröffentlichung ¹¹ , soweit erforderlich unter Angabe der maßgeblichen Teile ¹²	Betr. Anspruch Nr. ¹³
A	WO, A, 83/01535 (R. FRIEDL) 28. April 1983 --	
A	DE, B, 1079192 (LICENTIA) 7. April 1960 in der Anmeldung erwähnt --	
A	DE, B, 1133817 (LICENTIA) 26. Juli 1962 -----	
<p>* Besondere Kategorien von angegebenen Veröffentlichungen¹⁰:</p> <p>"A" Veröffentlichung, die den allgemeinen Stand der Technik definiert, aber nicht als besonders bedeutsam anzusehen ist</p> <p>"E" älteres Dokument, das jedoch erst am oder nach dem internationalen Anmeldedatum veröffentlicht worden ist</p> <p>"L" Veröffentlichung, die geeignet ist, einen Prioritätsanspruch zweifelhaft erscheinen zu lassen, oder durch die das Veröffentlichungsdatum einer anderen im Recherchenbericht genannten Veröffentlichung belegt werden soll oder die aus einem anderen besonderen Grund angegeben ist (wie ausgeluhrt)</p> <p>"O" Veröffentlichung, die sich auf eine mündliche Offenbarung, eine Benutzung, eine Ausstellung oder andere Maßnahmen bezieht</p> <p>"P" Veröffentlichung, die vor dem internationalen Anmeldedatum, aber nach dem beanspruchten Prioritätsdatum veröffentlicht worden ist</p> <p>"T" Spätere Veröffentlichung, die nach dem internationalen Anmeldedatum oder dem Prioritätsdatum veröffentlicht worden ist und mit der Anmeldung nicht kollidiert, sondern nur zum Verständnis des der Erfindung zugrundeliegenden Prinzips oder der ihr zugrundeliegenden Theorie angegeben ist</p> <p>"X" Veröffentlichung von besonderer Bedeutung; die beanspruchte Erfindung kann nicht als neu oder auf erfinderischer Tätigkeit beruhend betrachtet werden</p> <p>"Y" Veröffentlichung von besonderer Bedeutung; die beanspruchte Erfindung kann nicht als auf erfinderischer Tätigkeit beruhend betrachtet werden, wenn die Veröffentlichung mit einer oder mehreren anderen Veröffentlichungen dieser Kategorie in Verbindung gebracht wird und diese Verbindung für einen Fachmann naheliegend ist</p> <p>"&" Veröffentlichung, die Mitglied derselben Patentfamilie ist</p>		
IV. BESCHEINIGUNG		
Datum des Abschlusses der internationalen Recherche		Absendedatum des internationalen Recherchenberichts
2. Dezember 1986		21 JAN 1987
Internationale Recherchenbehörde		Unterschrift des bevollmächtigten Bediensteten
Europäisches Patentamt		M. VAN MOL 

ANHANG ZUM INTERNATIONALEN RECHERCHENBERICHT ÜBER DIE

INTERNATIONALE PATENTANMELDUNG NR. PCT/EP 86/00515 (SA 14443)

In diesem Anhang sind die Mitglieder der Patentfamilien der im obengenannten internationalen Recherchenbericht angeführten Patentedokumente angegeben. Die Angaben über die Familienmitglieder entsprechen dem Stand der Datei des Europäischen Patentamts am 11/12/86

Diese Angaben dienen nur zur Unterrichtung und erfolgen ohne Gewähr.

Im Recherchenbericht angeführtes Patentedokument	Datum der Veröffentlichung	Mitglied(er) der Patentfamilie	Datum der Veröffentlichung
WO-A- 8301535	28/04/83	DE-A- 3140544	21/04/83
		GB-A,B 2118372	26/10/83
		EP-A,B 0093727	16/11/83
DE-B- 1079192		Keine	
DE-B- 1133817		Keine	

Für nähere Einzelheiten zu diesem Anhang :
siehe Amtsblatt des Europäischen Patentamts, Nr. 12/82