

12

**EUROPEAN PATENT APPLICATION**

21 Application number: 89107590.5

51 Int. Cl.4: **E04B 5/57**

22 Date of filing: 26.04.89

30 Priority: 26.04.88 SE 8801536

43 Date of publication of application:  
02.11.89 Bulletin 89/44

84 Designated Contracting States:  
**AT BE CH DE ES FR GB GR IT LI LU NL SE**

71 Applicant: **IMAC AB**  
**Berga Allé 1**  
**S-252 55 Helsingborg(SE)**

72 Inventor: **Hakansson, Einar**  
**Anna Sömmerskas Väg 5**  
**S-237 00 Bjärred(SE)**

74 Representative: **Füchsle, Klaus, Dipl.-Ing. et al**  
**Hoffmann . Eitle & Partner Patentanwälte**  
**Arabellastrasse 4**  
**D-8000 München 81(DE)**

54 **Process for assemblage of self-supporting ceiling panels.**

57 The invention relates to a process for assemblage of self-supporting ceiling panels (1) in ships or buildings. Supporting profiles (5) provided with an upwards directed longitudinal flange (17) are applied along the upper part of two opposite walls (3). Several runners (6) having a lower, horizontally projecting tongue (10), a downwards directed flange (11) placed at the back and possibly an upper, horizontally projecting tongue (12) are hung up preferably opposite to each other in the flanges (17) of the supporting profiles (5) by means of the flanges (11), whereby the runners (6) can be pushed along the profiles (5). A panel (1) is placed on the tongues (10) of a first set of runners (6), whereupon the next panel (1) is placed on the tongues (10) of the next set of runners (6) and pushed together with the previous panel and so on until the whole ceiling has been installed.

**FIG. 6**

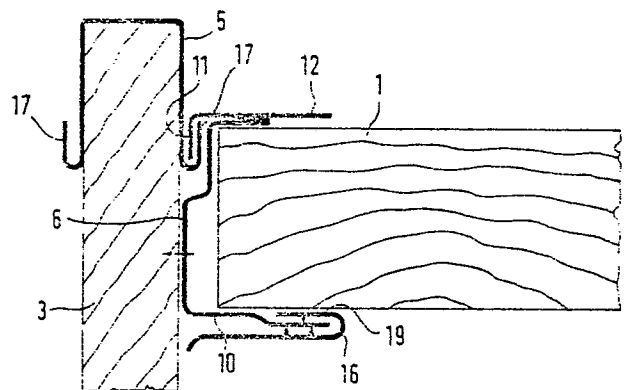

**EP 0 339 624 A2**

### Process for assemblage of self-supporting ceiling panels

The present invention relates to a process for assemblage of self-supporting ceiling panels.

There are many kinds of ceiling panels on the market. Usually these are mounted on downwards directed stays which are then attached to the building construction situated above.

Such a construction is connected with many problems if the space above the ceiling is needed for installations of different kinds, such as water pipings, discharge pipes and electric cables. The stays will then obstruct these pipes and cables.

Therefore, there is a great need to be able to erect a self-supporting ceiling without any such stays.

According to the present invention it has quite surprisingly been possible to satisfy this need and bring about a process for assemblage of self-supporting ceiling panels in ships or buildings.

According to the process, supporting profiles provided with an upwards directed longitudinal flange are applied along the upper part of two opposite walls. Many runners having a lower, horizontally projecting tongue, a downwards directed flange placed at the back and possibly an upper, horizontally projecting tongue are hung up preferably just opposite each other in the flanges of the supporting profiles by means of the downwards directed flanges on the runners. In this way the runners can be pushed along the supporting profiles.

At the assemblage of the panels, a first panel is placed on the lower tongues of a first set of runners, whereupon the next panel is placed on the lower tongues of the next set of runners and pushed together with the previous panel. Further panels are assembled in the same way until the whole ceiling has been put together.

According to the above brilliant process, the ceiling panels can be assembled wholly from the under side without using at all the space above the upper side of the ceiling for putting the ceiling panels into their final position.

The runners are suitably attached to the wall by means of screws, spring clips or the like. This is especially the case at the assemblage of the ceiling panels in ships.

Preferably, the panels are provided with recesses in the edges of the longitudinal sides for connecting the panels towards each other. Thereby, the panels are stiffened and fixed towards each other. The connection of the longitudinal sides of the panels can be arranged in different ways. For instance, a support strip can be inserted into the recesses.

If the recesses in the panels are formed as

groove and tenon or the like, the panels can be fixed towards each other without the use of any support strips.

5 In certain cases the panels are provided with reinforcing profiles at the back side.

At a preferred embodiment of the invention the supporting profiles have a U-formed cross section and are provided with an upwards directed longitudinal flange along each longitudinal side. The supporting profiles are then brought down over the upper edge of the walls. In this way the supporting profile can be used in both rooms on each side of the wall.

15 When a runner is used which is lacking an upper, horizontally projecting tongue, it is suitable that the panels are secured against displacement in vertical direction by means of stopping means which are firmly attached to the supporting profiles and comprise a horizontally projecting tongue.

20 To facilitate the assemblage of the final panel it is advantageous to apply a supporting profile also along the upper part of at least one of the two remaining walls. Stopping means are then attached to the supporting profile. In this case the upwards directed flange of the supporting profile is suitably provided with an opening.

25 The final panel is lifted in an connected with the last inner panel. The runners are inserted through the opening in the flange of the supporting profile and moved towards the side with the two flanges in engagement with each other. In this way the longitudinal outer edge of the panel is firmly attached between the tongues of the runners and the tongues of the stopping means.

30 The present invention will be explained further in connection with the enclosed figures, of which figure 1 shows in cross section from above a room with ceiling panels assembled according to the invention. Figures 2 and 3 show a perspective view of a cut out upper part of a wall provided with supporting profiles and two different kinds of runners. The supporting profile according to figure 3 is lacking an upwards directed flange in a part of its length. Figures 4 and 5 show in perspective from above cut out parts of ceiling panels while being assembled according to the invention. Figure 6 illustrates straight from the side a cut out part of the upper part of a wall with an installed supporting profile and a runner according to figure 2. Finally, figure 7 shows straight from the side a cut out part of the upper part of a wall with an erected supporting profile and a runner according to figure 3.

35 40 45 50 A combined edge trim and support ledge as well as the end of an assembled panel are also shown on figures 6 and 7.

At the assemblage of the ceiling shown on figure 1 ceiling panels 1, 2 with a width (B) and a length (S) have been used. The two opposite side walls have been designated with 3 and the shorter walls with 4.

At the installation of the ceiling panels 1, 2 supporting profiles 5 are first applied along the upper part of the two side walls. The profiles can be formed in different ways. However, they always have an upwards directed longitudinal flange 17.

At a preferred embodiment the profiles 5 have a U-formed cross section and are provided with an upwards directed longitudinal flange 17 along each side.

Many runners 6 (figures 2 and 6) or 7 (figures 3 and 7) comprising a lower, horizontally projecting tongue 10, a downwards directed flange 11 placed at the back and possibly an upper horizontally projecting tongue 12 (figures 2 and 6) are hung up, preferably just opposite each other in the flanges 17 of the supporting profiles 5 by means of the flanges 11. The runners can be pushed along the profiles 5.

For example two runners 6, 7 can be used at each shorter side of a panel (figures 4 and 5). However, also another number of runners can be used.

The order at the installation of the panels 1, 2 can be varied. At one suitable alternative you start with a final panel 2 (figure 1) at one of the shorter walls 4. When runners 6 for the first panel 2 have been hung up as mentioned above, the runners are suitably attached to the wall 3 by means of screws, spring clips or the like. Then the first panel is lifted up and pushed from the side in between the horizontally projecting tongues 10 and 12 of the runners 6.

If the alternative runners 7 (figure 3) are used instead, they are suitably combined with stopping means 9 which are firmly attached to the supporting profiles 5. The means 9 are provided with a horizontally projecting tongue 18. The panels are brought in between the tongues 10 and 18.

The next set of runners 6, 7 are attached towards the wall, whereupon an inner panel 1 is lifted up and placed between the tongues 10 and 12 and 10 and 18 respectively.

The other inner panels 1 are installed in the same way. Finally, it is time to install the final panel 2 at the other shorter wall. It is a bit more difficult to install said panel than the other panels, since you cannot put it up from the side if runners 6, 7 have been mounted right out to the corner.

The assemblage of the final panel 2 can be made in many different ways. For instance, a supporting profile 5 (fig. 3) can be attached along the upper part of the last shorter wall 4. Suitably the supporting profile 5 is then lacking a flange 17

along a portion 8 of its length (figure 3).

Stopping means 9 are mounted on the wall 4. The final panel 2 can now be lifted up and connected with the last one of the installed inner panels 1. Runners 7 are then brought into the flange 17 on the supporting profile 5 through the opening 8 present in the flange 17. The runners 7 can be pushed towards both sides, whereby the panel 2 is firmly attached between the tongues 10 and 18 (figure 3).

The panels 1, 2 are preferably provided with recesses 13 in the edges of the longitudinal sides (figures 4 and 5) for stiffening and fixing the panels towards each other. At the installation support strips 14 can be inserted into these recesses 13.

If desired, it is possible instead to start with the installation of an inner panel 1 about in the middle of the room and then continue towards both directions. Then you need supporting profiles according to figure 3 along both of the shorter walls 4.

At the installation of the final panel 2, as disclosed above, blocks 15 (figure 7) can be used. They are inserted into the runners 7 between these and the longitudinal side of the panel. Thereby, the last panel 2 is pressed inwards towards the room and it is firmly anchored in its proper position in spite of the fact that it must be a bit too narrow to make it possible to be installed.

A combined edge trim and support ledge 16 (figures 6 and 7) can be used together with the runners 6, 7 and installed when all panels 1, 2 have been assembled. The ledge 16 is suitably provided with a flat longitudinal part 19 which is pushed in between the tongues 10 and the under side of the panels 1 and 2.

Of course, it is possible instead to use conventional edge trims which are possibly attached by nails or screws.

The invention is not limited to the embodiments shown, since these can be modified in different ways within the scope of the present invention. For instance, the design of the supporting profiles as well as the runners can be changed as compared to the embodiment examples shown in the drawings.

### Claims

1. Process for assemblage of self-supporting ceiling panels in ships or buildings, wherein supporting profiles provided with an upwards directed longitudinal flange, are applied along the upper part of two opposite walls, that many runners having a lower horizontally projecting tongue, a downwards directed flange placed at the back and possibly an upper horizontally projecting tongue are hung up preferably just opposite each other in the flanges of

the supporting profiles by means of the downwards directed flanges, whereby the runners can be pushed along the profiles, that one panel is placed on the lower tongues of a first set of runners, whereupon the next panel is placed on the lower tongues of the next set of runners and pushed together with the previous panel and so on until the whole ceiling is assembled. 5

2. Process according to claim 1, wherein the runners are attached to the wall by means of screws, spring clips or the like. 10

3. Process according to claim 1 or 2, wherein the panels are provided with recesses in the edges of the longitudinal sides, which recesses are intended to receive a support strip for stiffening and fixing the panels towards each other. 15

4. Process according to claim 1 or 2, wherein the panels are provided with recesses in the form of groove and tenon or the like in the edges of the longitudinal sides for fixing the panels towards each other. 20

5. Process according to anyone of claims 1-4, wherein the supporting profiles have a U-formed cross section and are provided with an upwards directed longitudinal flange along each longitudinal side, whereby the supporting profiles are brought down over the upper edge of the walls. 25

6. Process according to any one of claims 1-5, wherein the runners are lacking an upper tongue, whereby the panels are secured against displacement in vertical direction by means of stopping means which are firmly attached to the supporting profiles and comprise a horizontally projecting tongue. 30

7. Process according to any one of claims 1-6, wherein a supporting profile is applied also along the upper part of at least one of the remaining walls to facilitate the assemblage of the final panel, that stopping means are firmly attached to the supporting profile, that the upwards directed flange is provided with an opening, that the final panel is lifted in and connected with the last inner panel, whereupon runners are inserted through the opening in the upwards directed flange and moved towards the side with the flange of the runner in engagement with the upwards directed flange of the supporting profile, whereby the longitudinal outer edge of the final panel is firmly attached between the tongues on the runners and the tongues on the stopping means. 35  
40  
45  
50

55

Neu eingereicht / Newly filed  
Nouvellement déposé

FIG. 1

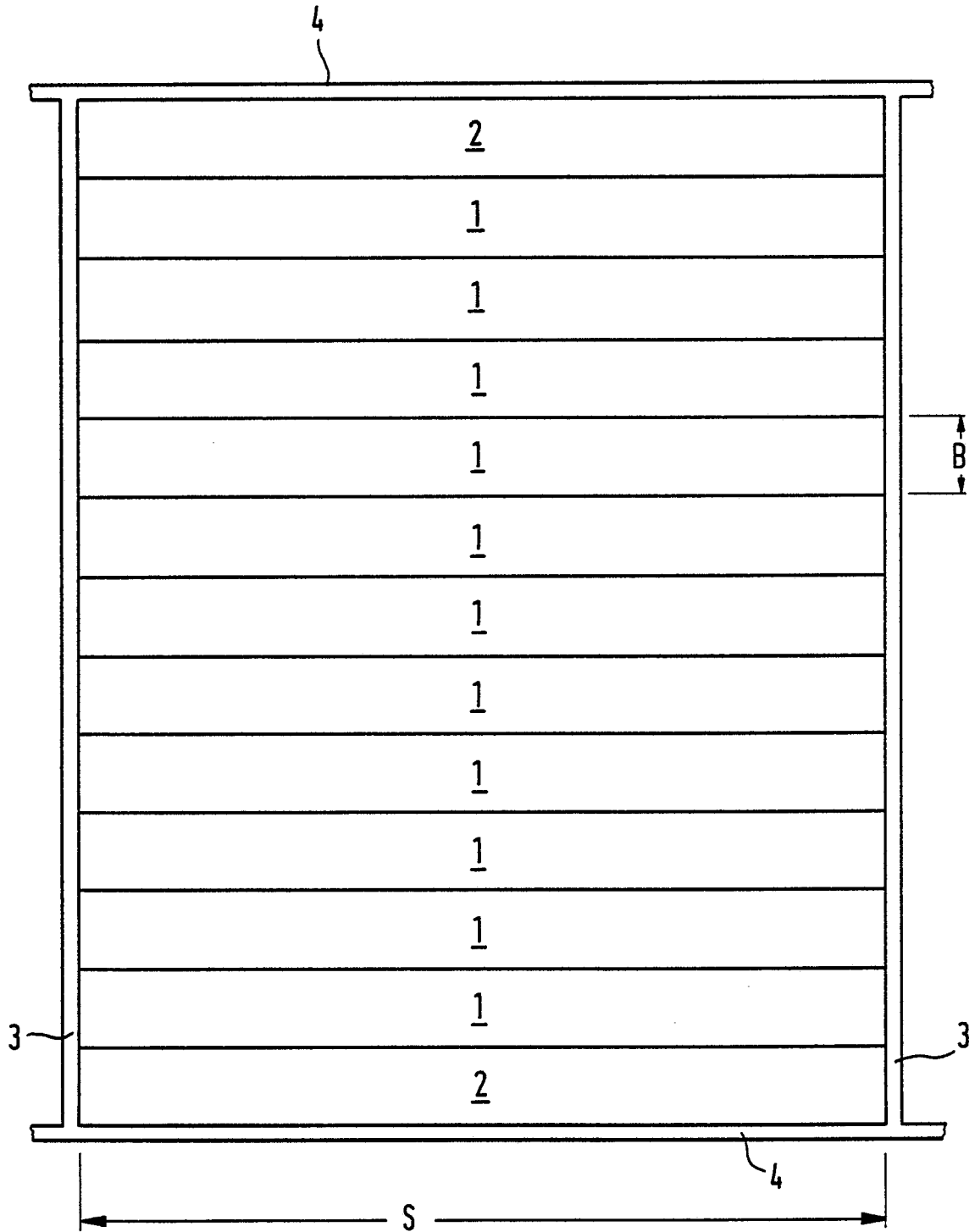

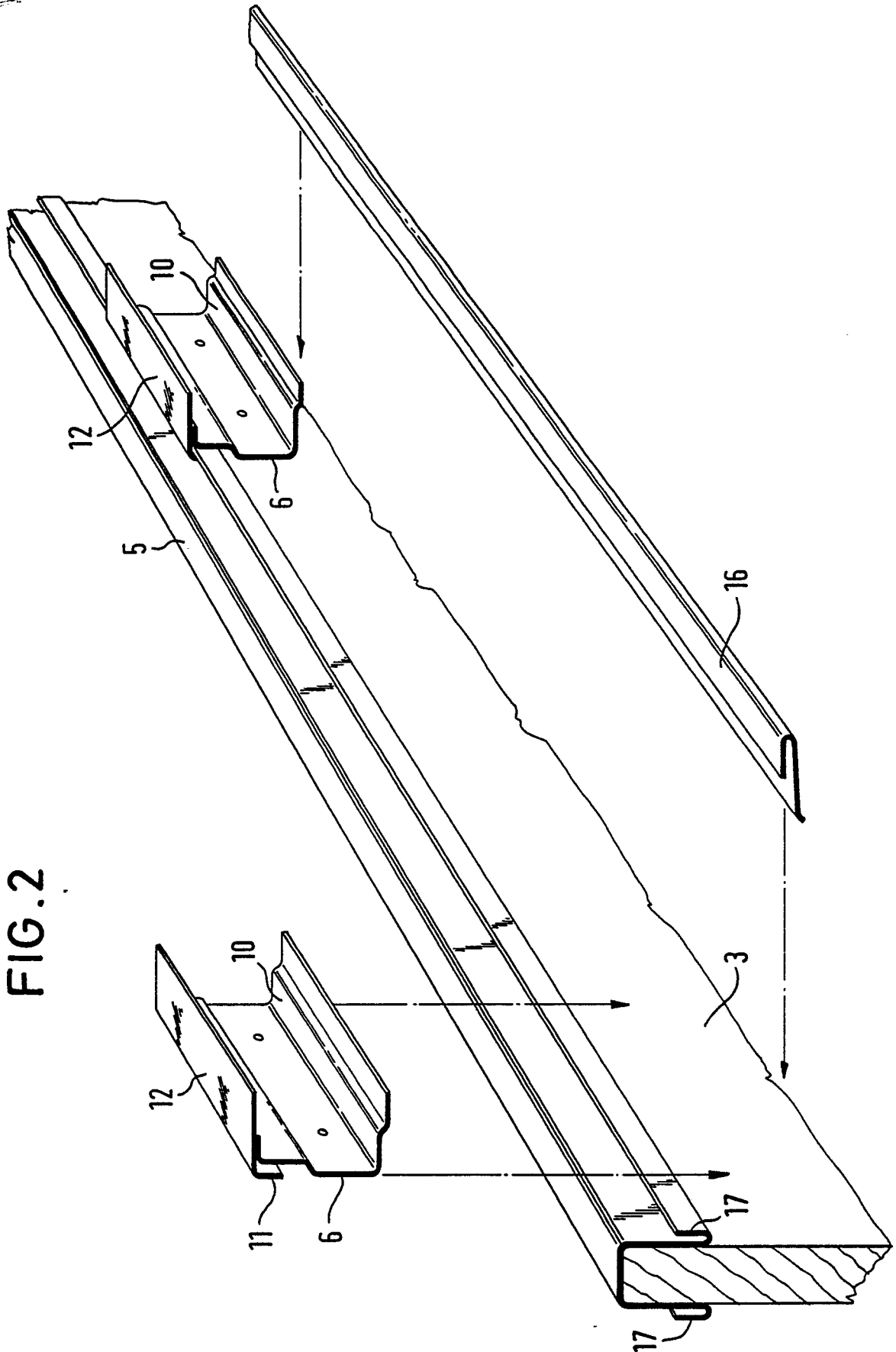

Produced by the  
Office of the  
Notary General

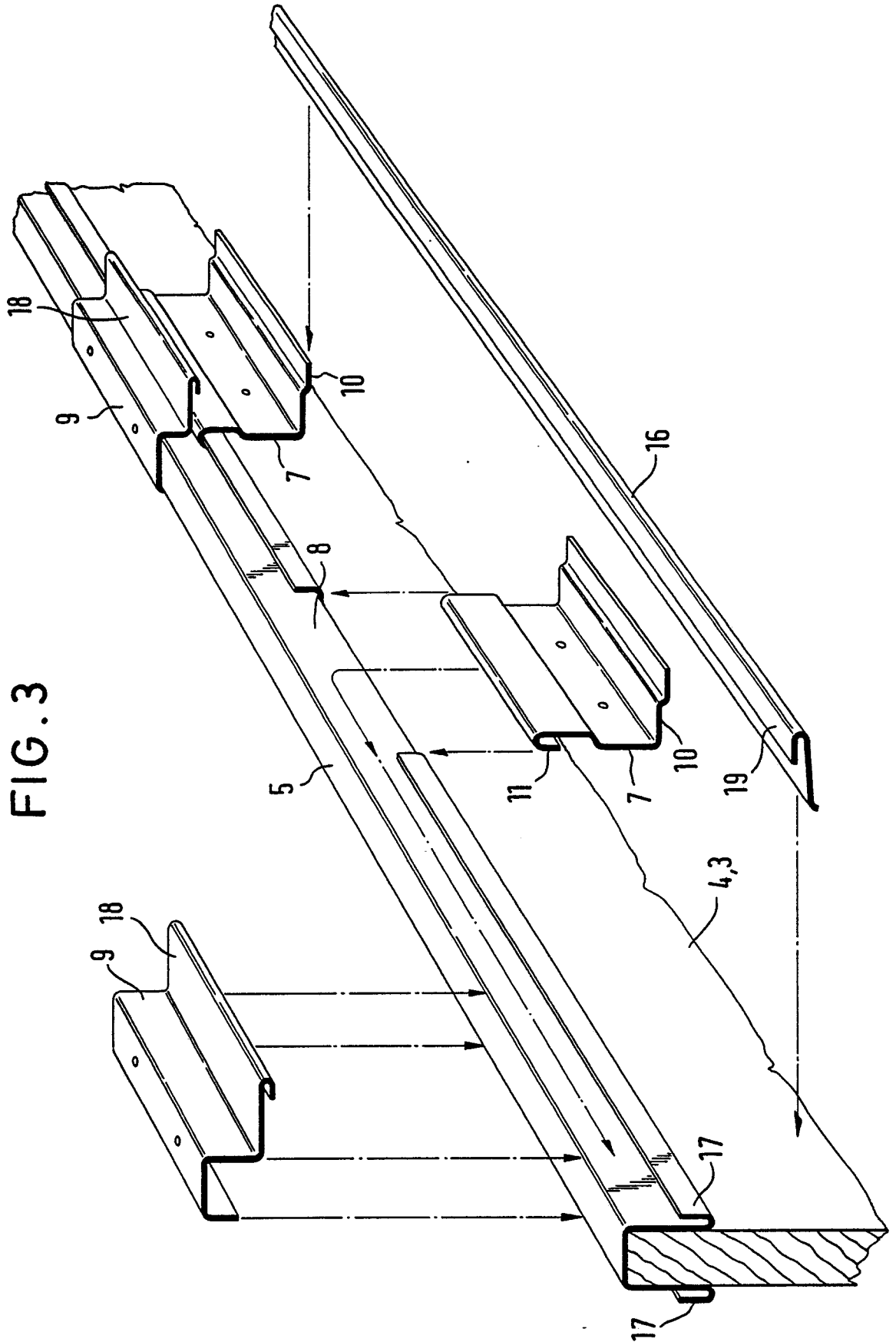

FIG. 3

FIG. 4

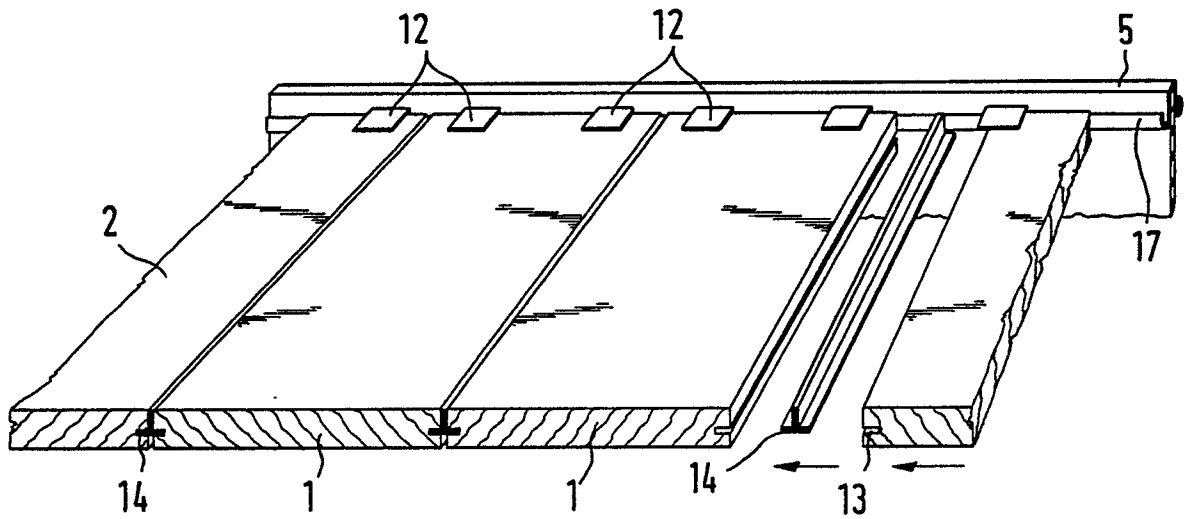

FIG. 5

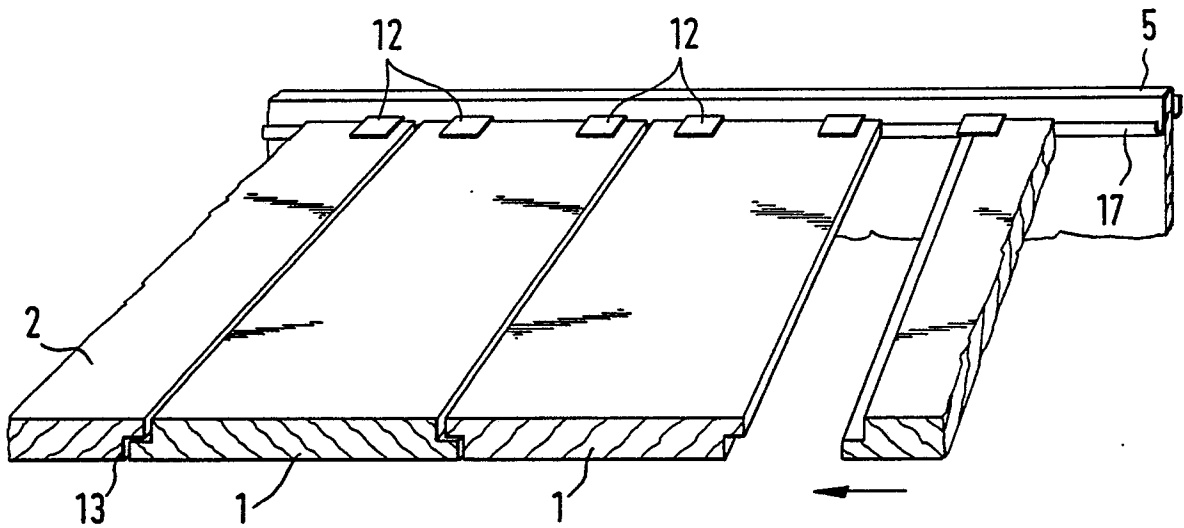

FIG. 6

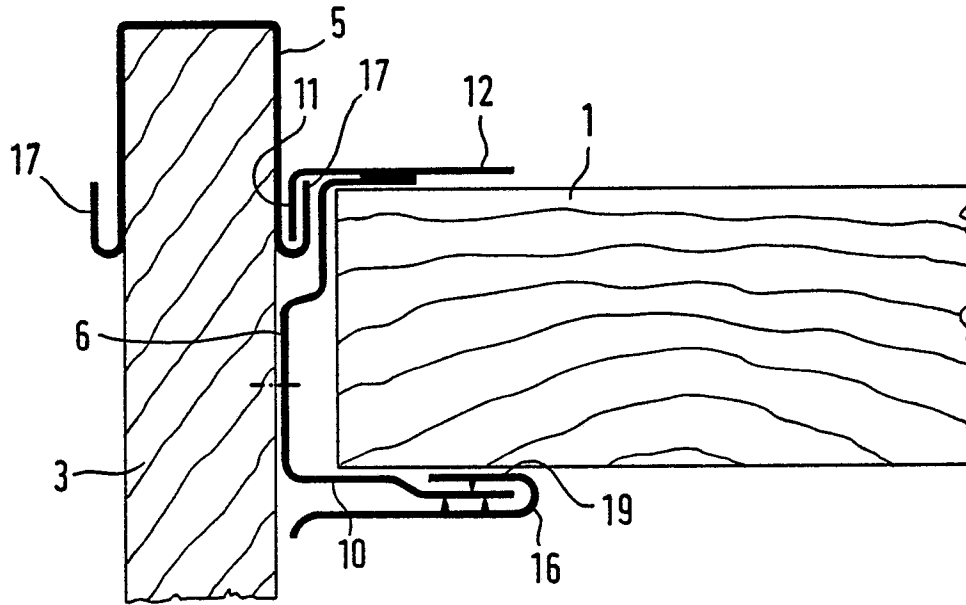

FIG. 7

