



US 20060094271A1

(19) **United States**

(12) **Patent Application Publication**
Zhang et al.

(10) **Pub. No.: US 2006/0094271 A1**

(43) **Pub. Date: May 4, 2006**

(54) **ELECTRICAL CONNECTOR WITH
DETACHABLE PICK-UP DEVICE**

Publication Classification

(75) Inventors: **Chi Zhang**, Kunsan (CN); **Ren-Chih Li**, Tu-Chen (TW)

(51) **Int. Cl.**
H01R 13/44 (2006.01)
(52) **U.S. Cl.** **439/135**

Correspondence Address:
WEI TE CHUNG
FOXCONN INTERNATIONAL, INC.
1650 MEMOREX DRIVE
SANTA CLARA, CA 95050 (US)

(57) **ABSTRACT**

An electrical connector (100) includes an insulative housing (1) formed with a mating slot (12) and defining a mating direction; a plurality of terminals (2) loaded in the housing, each terminal provided with a resilient contact portion (21) protruding into the mating slot, the contact portion enabled to deflect along a direction substantially perpendicular to the mating direction; and a pick-up device (4) having a main body (41) with a smooth upper surface (411) for vacuum section and a retaining portion (42) extending down from the main body and inserted into the mating slot. The retaining portion is provided with a nose (423) pushed through the contact portions to engage with the contact portions along the mating direction.

(73) Assignee: **HON HAI PRECISION IND.CO., LTD.**

(21) Appl. No.: **11/159,982**

(22) Filed: **Jun. 22, 2005**

(30) **Foreign Application Priority Data**

Nov. 4, 2004 (CN) 2004200809287

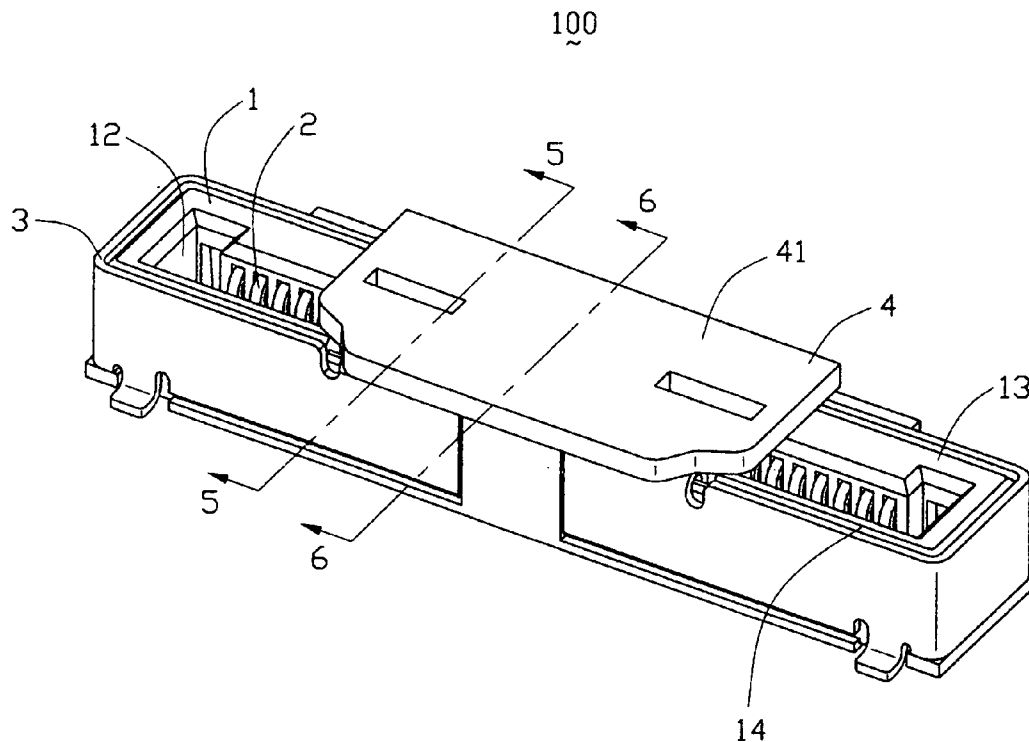

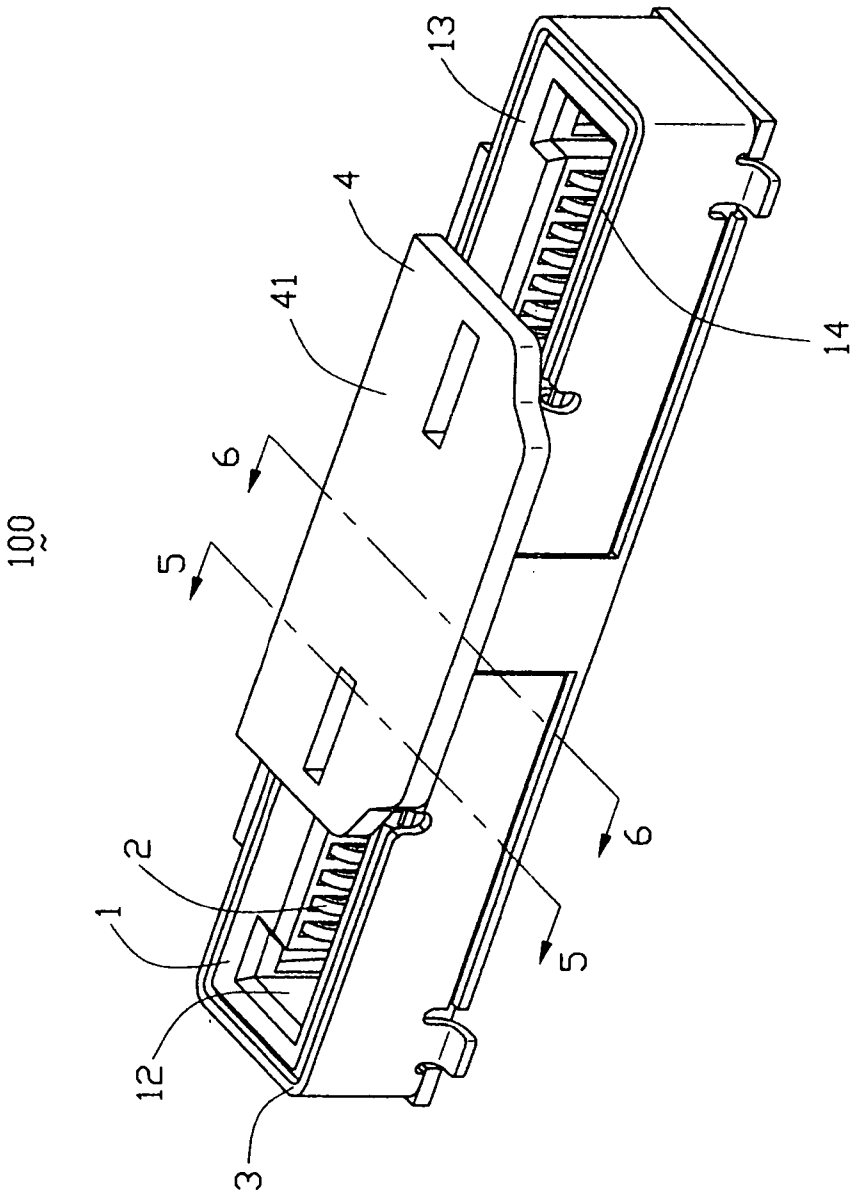

FIG. 1

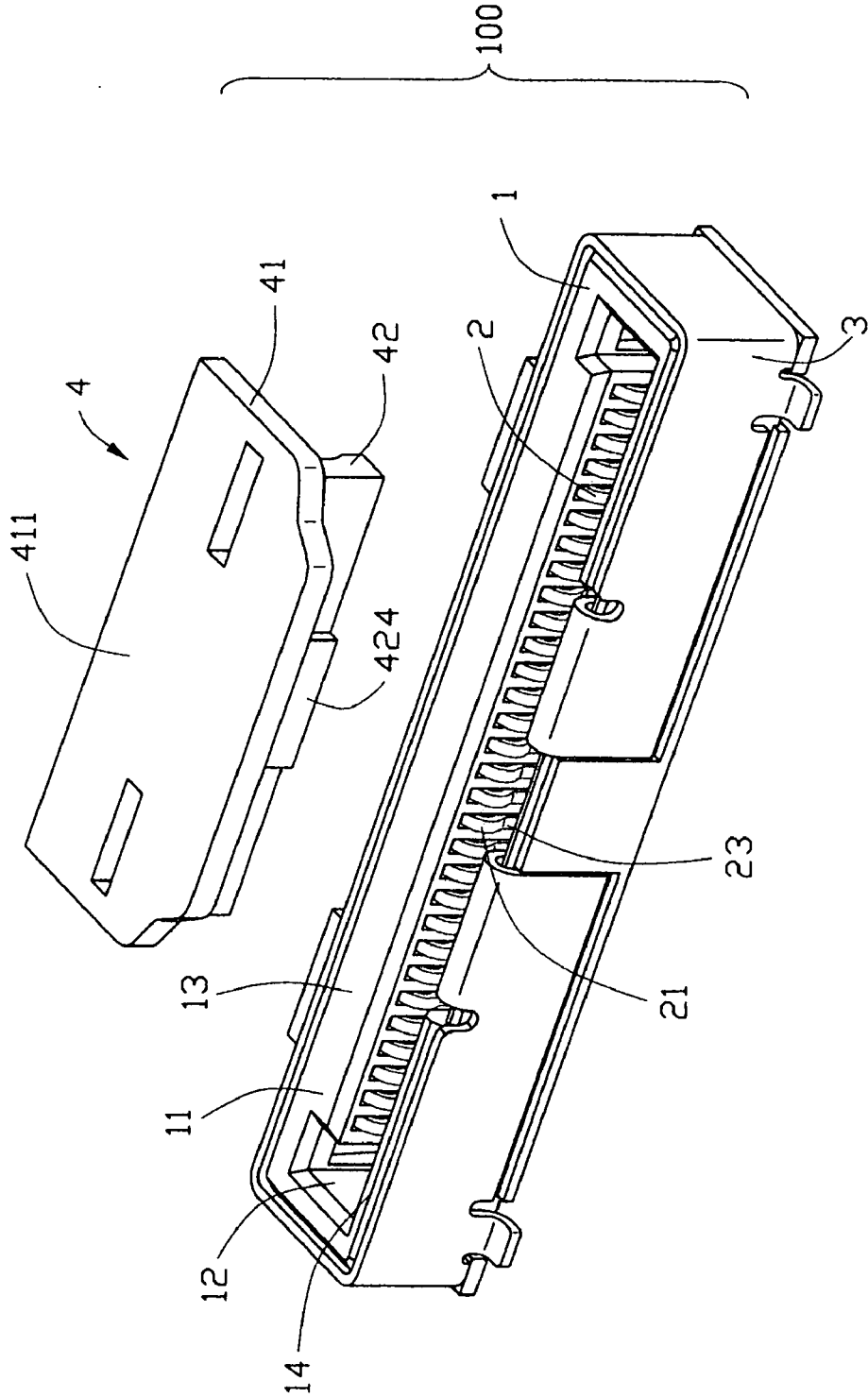

FIG. 2

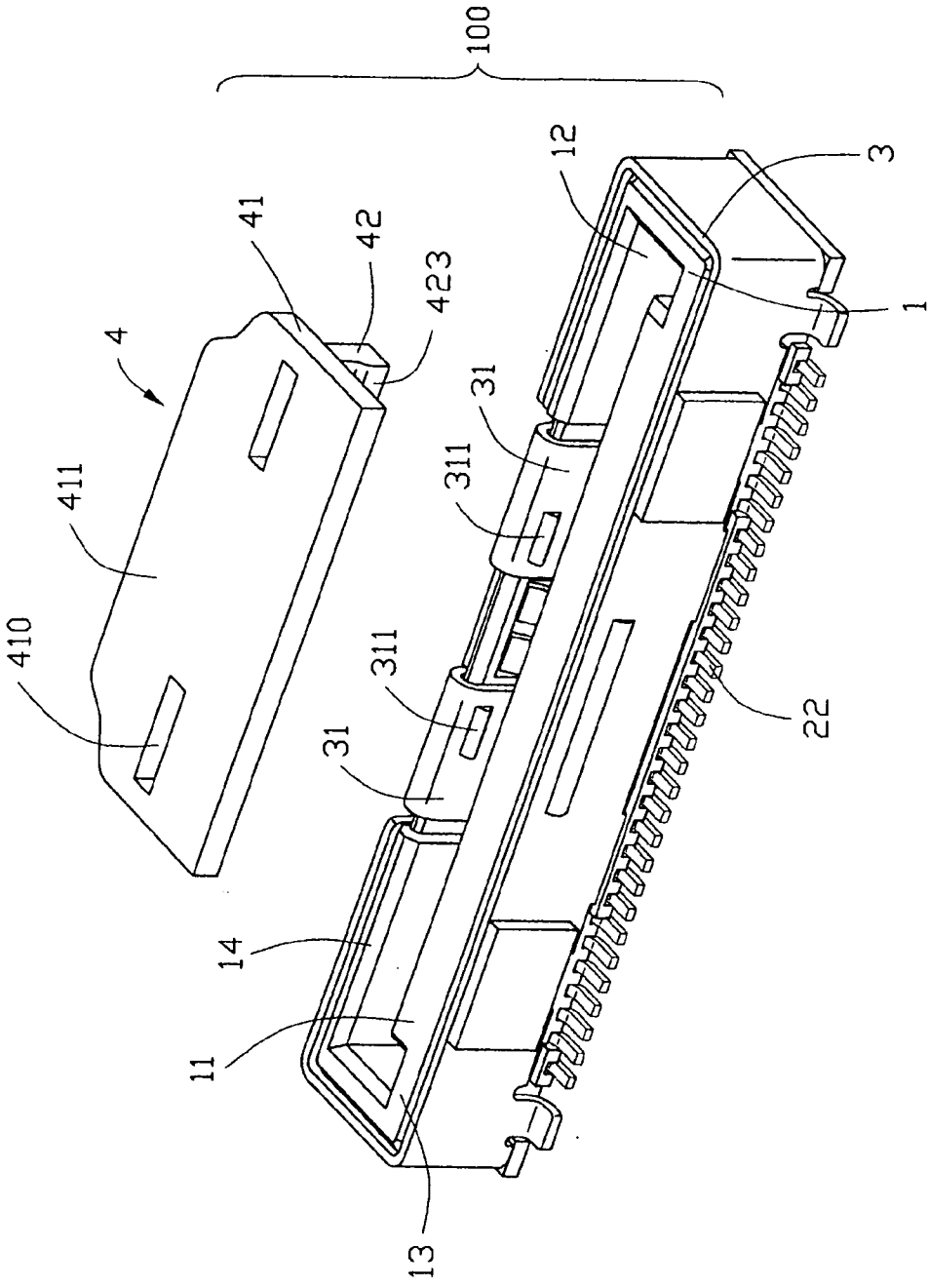

FIG. 3

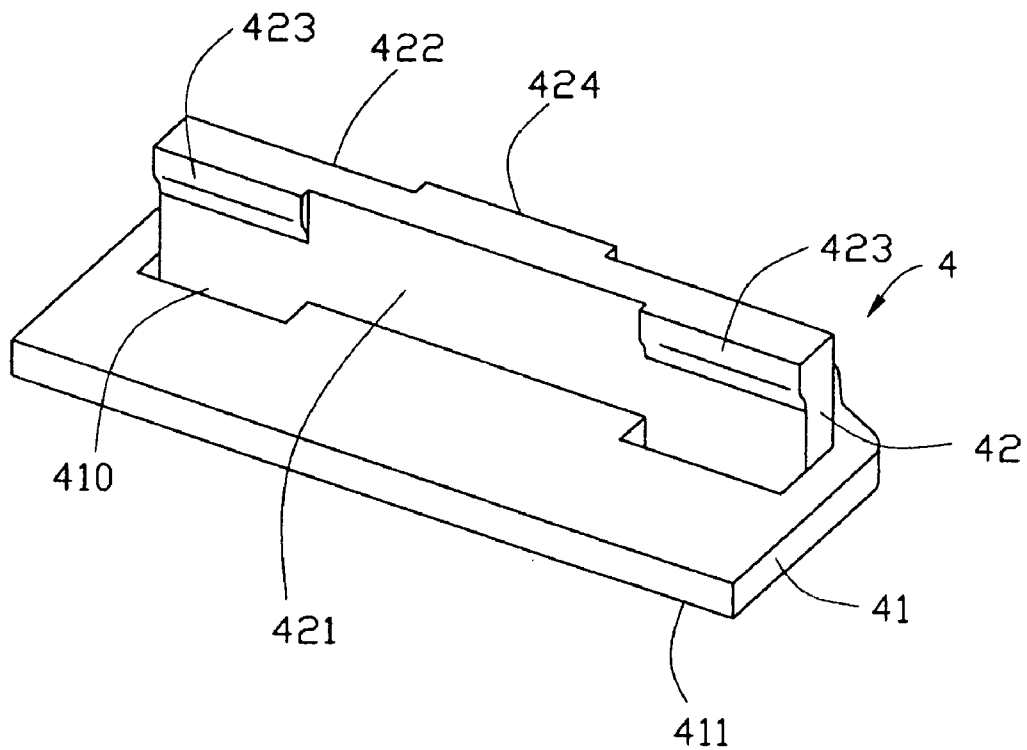

FIG. 4

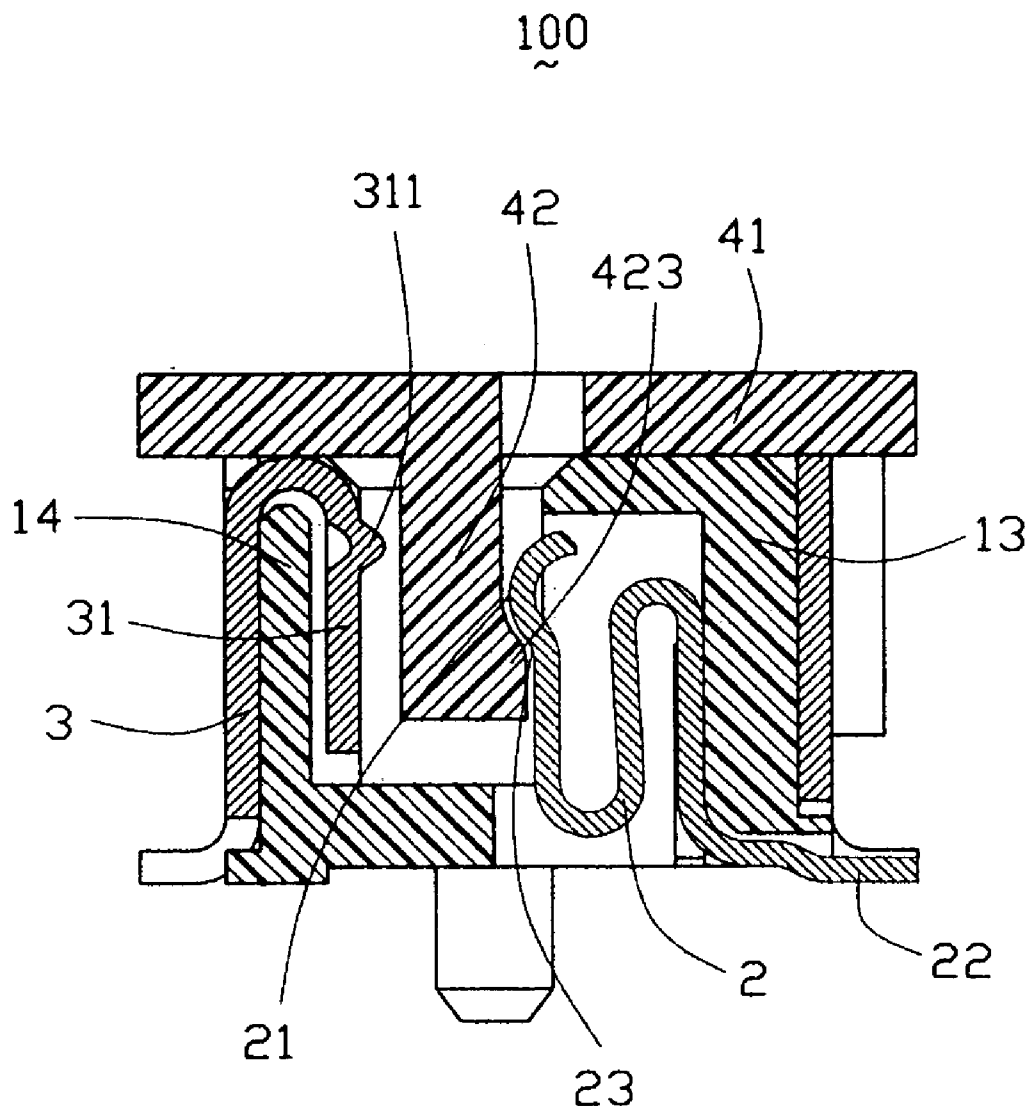

FIG. 5

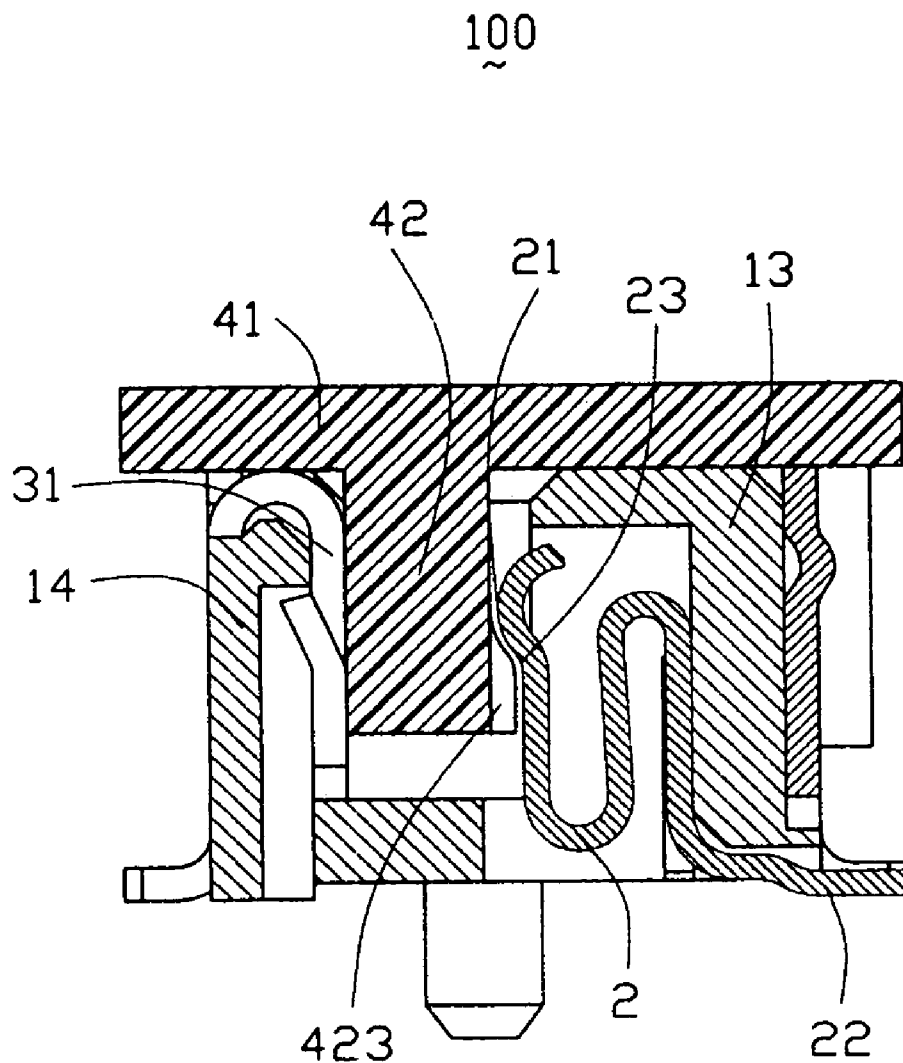

FIG. 6

ELECTRICAL CONNECTOR WITH DETACHABLE PICK-UP DEVICE

BACKGROUND OF THE INVENTION

[0001] 1. Field of the Invention

[0002] The present invention relates to an electrical connector, and more particularly to an electrical connector having a detachable pick-up cap.

[0003] 2. Description of Related Art

[0004] Electrical connectors including pick-up means for facilitating picking up and positioning by a pick-up machine such as a vacuum suction nozzle or the like are well-known. For example, U.S. Pat. No. 5,688,133 discloses such a connector with a pick-up cap. The pick-up cap comprises a flat cover plate and pairs of resilient legs descending downwardly from edges of the cover plate to engage sidewalls of the connector. The legs include main legs gripping outside of the sidewalls and auxiliary legs abutting against inner surfaces of the sidewalls. With this arrangement, each sidewall of the connector is, in effect, sandwiched between the main and auxiliary legs to be picked up via the force applied thereto by the legs while the pick-up cap is taken up by suction of a vacuum suction nozzle upon the flat cover plate thereof. Then the connector is transferred to a printed circuit board (PCB) and positioning them in a preselected position for soldering. The pick-up cap remains in place upon the connector until after it is joined to the PCB by soldering. So, the sidewalls of the connector are under the gripping force applied by the legs of the pick-up cap all the while during passing through the reflow vessel for soldering. As the auxiliary legs punched out of the main legs are shorter than the main legs, the auxiliary legs and the main legs respectively abut against the sidewalls on their upper portions and lower portions. As a result, the main legs press the sidewalls slightly inwardly while the auxiliary legs press the sidewalls slightly outwardly, which may cause deformation or warpage of the connector on the sidewalls. If once such deformation or warpage occur, it will potentially result in misalignment and misengagement between the connector and its mating connector.

[0005] U.S. Pat. No. 6,019,617 discloses another conventional connector with a pick-up cap. The pick-up cap disclosed therein has two pairs of resilient legs each provided with a hook-like end to be forced into channel formed in sidewall of the connector. In the process of the resilient legs being forced into the channel, the hook-like ends thereof apply a force to the sidewalls, but that force is in a longitudinal direction along the sidewalls and will rarely cause deformation of the connector. Once the legs detained in the channels, the pick-up cap will not apply force to the sidewalls anymore, except a hooking force upwardly along the sidewalls when the pick-up cap is taken up by suction of a vacuum suction nozzle and the connector is hooked up by the pick-up cap. Thus the connector will rarely suffer deformation or warpage while passing through the reflow vessel for soldering. However, this kind of pick-up cap requires channels to be defined in sidewalls of the connector for its legs with hook-like ends, which not only complicates the machining procedure of the connector but also weakens the sidewalls of the connector.

[0006] Therefore, to overcome the disadvantages of the prior arts, an improved connector with a pick-up cap is desired.

SUMMARY OF THE INVENTION

[0007] An object of the present invention is to provide a connector having a pick-up cap which farthest reduces the deformation in the connector while passing through a reflow vessel.

[0008] Another object of the present invention is to provide a connector with a pick-up cap, which is easy to produce and assemble.

[0009] In order to achieve above-mentioned objects, an electrical connector in accordance with a preferred embodiment of the present invention includes an housing formed with a mating slot and defining a mating direction; a plurality of terminals loaded in the housing, each terminal provided with a resilient contact portion protruding into the mating slot and enabled to deflect along a direction substantially perpendicular to the mating direction; and a pick-up device having a main body with a smooth upper surface for vacuum section and a retaining portion extending down from the main body and inserted into the mating slot. The retaining portion is provided with a nose pushed through the contact portions to engage with the contact portions along the mating direction.

[0010] Other objects, advantages and novel features of the present invention will become more apparent from the following detailed description of the present embodiment when taken in conjunction with the accompanying drawings.

BRIEF DESCRIPTION OF THE DRAWINGS

[0011] FIG. 1 is an assembled view of a connector with a pick-up cap in accordance with the preferred embodiment of the present invention;

[0012] FIG. 2 is an exploded perspective view of the connector of FIG. 1;

[0013] FIG. 3 is an exploded perspective view of the connector of FIG. 1 taken from another aspect;

[0014] FIG. 4 is a perspective view of the pick-up cap of FIG. 1;

[0015] FIG. 5 is a cross-sectional view of the connector of FIG. 1 taken along line 5-5; and

[0016] FIG. 6 is a cross-sectional view of the connector of FIG. 1 taken along line 6-6.

DETAILED DESCRIPTION OF THE INVENTION

[0017] Reference will now be made to the drawing figures to describe the preferred embodiment of the present invention in detail. Referring to FIGS. 1-3, a connector in accordance with the present invention comprises an insulative housing 1, a plurality of terminals 2 loaded in the housing 1, a shell 3 attached to a periphery of the housing 1, and a pick-up cap 4 detachably assembled to the housing 1.

[0018] The housing 1 that is of a rectangular structure has a pair of opposite longitudinal sidewalls 13, 14 which define a slot 12 therebetween opening to a mating face 11 of the housing 1 to receive a mating connector. One of the sidewalls 13 defines a plurality of terminal-receiving grooves, each of which receives one terminal 2. The terminal 2 has a

crooked head **21** protruding into the mating slot **12** to serve as a contact portion for electrically contacting a conductor on the mating connector and a tail **22** horizontally coming out of the housing **1** to serve as a solder portion to be soldered to a printed circuit board (PCB). Turning to **FIG. 5**, to join the crooked head **21** and the horizontally tail **22**, the terminal **2** further has a S-shaped body portion (not labeled), which enable the contact portion **21** to perform resilience in a breadth direction. The crooked head **21** gives a lower section **23** of the terminal **2** closely extending therefrom, that is a joint of the crooked head **21** and the body portion, a concavity appearance.

[0019] Referring to **FIG. 3**, the shell **3** attached on the periphery of the housing **1** has a pair of stooped pieces **31** bent down onto an inner surface of the sidewall **14**. That pair of pieces **31** are comparted by an inwardly bulged middle of the sidewall **14** in a longitudinal direction, and each has a rib **311** thereon protruding into the mating slot **12**.

[0020] Referring to **FIGS. 2-4**, wherein **FIG. 4** shows the pick-up cap **4** being inverted, the pick-up cap **4** comprises a flat cover plate **41** having a smooth upper surface **411** for receiving vacuum suction from a pick-up machine (not shown) and a retaining leg **42** extending downwardly from the cover plate **41** to be inserted into the mating slot **12** of the housing **1**. From a first side **421** of the retaining leg **42** project a pair of rims **423** at its edge remote from the cover plate **41**. Oppositely, there is a protuberant block **424** formed at the opposite second side **422** of the retaining leg **42** and extending from an end of the retaining plate **42** adjacent to the cover plate **41** to the other end remote from the cover plate **41**. Wherein along a longitudinal direction of the retaining leg **42** corresponding to that of the elongated mating slot **12**, the block **424** is located in middle of the pair of rims **423**. Additionally, the cover plate **41** defines a pair of aperture **410** therethrough corresponding to the rims **423** for purpose of mold-pulling.

[0021] Referring to **FIGS. 5 and 6** together, in use, the pick-up cap **4** is assembled to the housing **1** with the retaining leg **42** thereof inserted into the mating slot **12** and the cover plate **41** thereof covering upon the mating face **11**. During the inserting process, the block **424** on the retaining leg **42** slides into the mating slot **12** from a gap between the pair of ribs **311** to be locked therebetween for preventing the pick-up cap **4** from longitudinally moving, and the rims **423** pushes through the contact portions **21** of the terminals **2** to be detained at the concavity **23** thereof. Thus, the connector **100** can be picked up via an upward force on the contact portions **21** applied by the rims **423** of the pick-up cap **4**. The retaining leg **42** of the pick-up cap **4** is sized to being fitly received in the mating slot **12** but not inflicting a force onto the sidewalls **13, 14**, that is to say, a maximal size of the retaining leg **42** in width is not larger than that of the mating slot **12**. So, when the connector **100** is taken into a reflow vessel for soldering via the pick-up cap **4**, the sidewalls **13, 14** will rarely suffer deformation or warpage.

[0022] The disclosure is illustrative only, changes may made in detail, especially in matter of shape, size, and arrangement of parts within the principles of the invention.

1. An electrical connector assembly comprising:

an insulative housing formed with a mating slot and defining a mating direction;

a plurality of terminals loaded in the housing, each terminal provided with a resilient contact portion protruding into the mating slot, the contact portion deflectable along a direction substantially perpendicular to the mating direction; and

a pick-up device having a main body with a smooth upper surface for vacuum section and a retaining portion extending down from the main body and inserted into the mating slot, the retaining portion provided with a nose pushed through the contact portions to engage with the contact portions along the mating direction,

wherein the terminals are all arranged in one side of the mating slot.

2. The electrical connector assembly as described in claim 1, wherein a maximal size of the retaining portion in width is not larger than that of the mating slot.

3. (canceled)

4. The electrical connector assembly as described in claim 1, wherein the other side of the mating slot has a pair of protuberances thereon, and the retaining portion has a block received between the protuberances to prevent the pick-up device from moving along the mating slot.

5. The electrical connector assembly as described in claim 4, wherein the retaining portion defines a longitudinal direction corresponding to the mating slot, the block located in longitudinal middle of the retaining portion, and the nose separated into two parts respectively positioned at longitudinal ends of the retaining portion.

6. The electrical connector assembly as described in claim 5, wherein the block extends from the main body to an end edge of the retaining portion remote from the main body, and each one of the two parts of the nose is a rim by the end edge of the retaining portion.

7. The electrical connector assembly as described in claim 1, further comprising a shell attached on a periphery of the housing.

8. The electrical connector assembly as described in claim 7, wherein the shell has a pair of stooped pieces bent down onto an inner surface of the mating slot.

9. An electrical connector assembly comprising:

an insulative housing defining along a longitudinal direction an elongated slot between opposite first and second longitudinal side walls thereof;

a plurality of contacts disposed in the first longitudinal side wall of the housing by one side of said slot in a transverse direction perpendicular to said longitudinal direction, each of said contacts defining a flexible contact beam with a contact portion extending into the slot;

an insulative pick-up cap defining a flat plate covering at least a portion of the slot in a vertical direction perpendicular to both said longitudinal direction and said transverse direction, at least one retaining leg downwardly extending from an underside of said flat plate and into the slot, a transversely protruding rim located around a first face of the retaining leg, confronting the contacts in the transverse direction and with the contact portion for holding the cap to the housing for preventing inadvertent upward movement of said cap along the vertical direction;

a second face of said retaining leg being opposite to said first face, a first portion of said second face, which is located opposite to said rim, being spaced from the second longitudinal side wall of the housing with a large distance without engagement while a second portion of said second face, which is offset from said rim with a distance in said longitudinal direction, being spaced from the second longitudinal side wall of the housing with a small distance.

10. The electrical connector assembly as claimed in claim 9, wherein said flat plate defines an opening in alignment with said rim in the vertical direction.

11. The electrical connector assembly as claimed in claim 9, wherein a metallic shield essentially horizontally encloses exterior faces of the housing, said shield including an inner portion covering a portion of an interior face of the second side wall of the housing facing the slot, and wherein the first portion of the pick-up cap is spaced from said inner portion while said second portion of the pick-up cap is engaged with said inner portion.

12. An electrical connector assembly comprising:

an insulative housing defining along a longitudinal direction a longitudinal slot between opposite first and second longitudinal side walls thereof;

a plurality of contacts disposed in the first side wall of the housing with contact portions extending into the slot;

a metallic shield horizontally covering exterior faces of the housing and further including an inner portion covering a portion of an interior face of the second side wall of the housing facing the slot; and

a pick-up cap defining a flat top plate covering at least a portion of the slot, a retaining leg downwardly extending from the flat top plate and into the slot; wherein

said retaining leg defining first and second engagement portions respectively on opposite first and second faces thereof while being offset from each other in said longitudinal direction, said first engagement portion engaging the contact portions but not the inner portion of shield, and said second engagement portion engaging the inner portion of the shield but not the contact portion.

13. The electrical connector assembly as claimed in claim 12, wherein said flat plate defines an opening in alignment with the first engagement portion rim in a vertical direction.

* * * * *