

F. GROLÉAS.
 CYCLE LOCK.
 APPLICATION FILED OCT. 19, 1910.

1,000,800.

Patented Aug. 15, 1911.

FIG. 1.

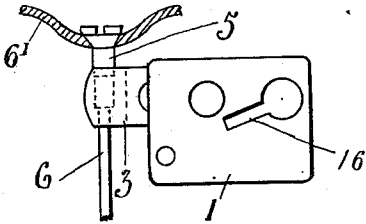

FIG. 2.

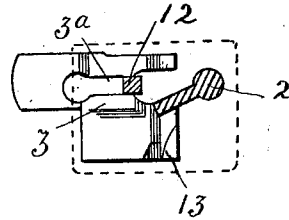

FIG. 4.

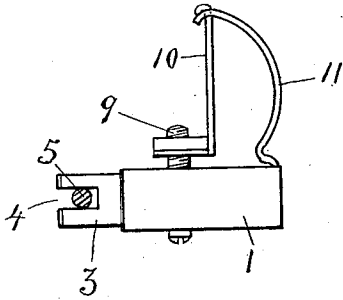

FIG. 3.

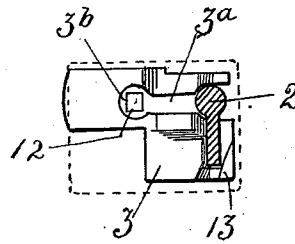

FIG. 6.

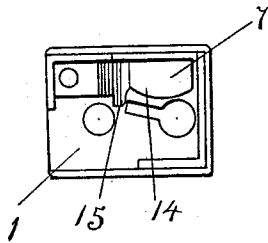

FIG. 5.

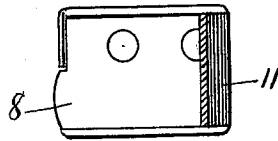

FIG. 7.

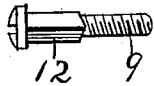
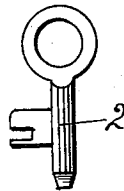

FIG. 8.



Witnesses
G. M. Coppenhaver,
Harry J. Reuth

Inventor

F. Groléas
J. Dittmar,

334

Attorney

UNITED STATES PATENT OFFICE.

FERDINAND GROLÉAS, OF LYON, FRANCE.

CYCLE-LOCK.

1,000,800.

Specification of Letters Patent. Patented Aug. 15, 1911.

Application filed October 19, 1910. Serial No. 537,922.

To all whom it may concern:

Be it known that I, FERDINAND GROLÉAS, a citizen of the French Republic, residing at Lyon, in France, have invented certain new and useful Improvements in Cycle-Locks, of which the following is a specification.

The present invention relates to a lock for preventing theft of cycles, motorcycles and the like, and comprises the novel features and combinations of parts hereinafter fully described and specifically pointed out in the appended claim, reference being made to the accompanying drawings which show an embodiment of the device and in which—

Figure 1 is an elevation thereof adapted for operation by means of a key of the shape usually provided for ordinary locks. Fig. 2 is a section showing the position of said key (in the locking position) with relation to the bolt which it operates. Fig. 3 is a similar view to Fig. 2 showing the parts in unlocked position. Fig. 4 is a plan view showing also the means by which the device is attached to the cycle for instance to the rear fork thereof. Fig. 5 is a detail view showing the cover of the lock casing one of the attaching clips being shown in section. Fig. 6 is a detail view of the lock with the cover and bolt removed. Fig. 7 is a detail view of special screw hereinafter referred to of partly square or rectangular formation and Fig. 8 is an elevation of a simple form of key.

In the casing 1 is located the bolt 3 actuated by the key 2 said bolt being adapted to assume either the unlocking position shown in Fig. 3 or the locking position shown in Fig. 2. The bolt has a bifurcated outer end 4 which in the locking position embraces either the screw or nipple 5 of one of the spokes 6 of the wheel 6^a or the spoke itself according to requirements. The casing 1 which also incloses the spring 7 is provided with a cover 8 secured in place by the screw 9, which extends through the casing and engages the angular clip member 10 forming part of the fixing device which is completed by the curved clip member 11 secured to the casing. The bolt 3 is provided with a recess 3^a which prevents the screw 9 from turning when the device is in the locking position (Fig. 2) but allows it to be screwed or unscrewed when the device is unlocked (Fig. 3) this result being obtained by means of the square or rectangular part 12 of said

screw engaging the straight walls of said recess or entering circular part 3^b at the end thereof respectively.

In the position shown in Fig. 2 the key 2 can be inserted or removed but if said key is turned to the position shown in Fig. 3 it engages a projection 13 on the bolt 3 and withdraws said bolt to unlock the device; at the same time acting on the spring 7 by engaging the small inclined or curved plane 14 thereof thus compressing said spring and disengaging the bolt from the stop 15 formed by a slightly raised part of the spring 7. When the device is unlocked said spring 7 still bears against parts of the bolt and prevents the same from being accidentally displaced so that the key cannot become detached or be removed from the device until it is moved to the locking position in which the bolt is in the position shown in Figs. 1 and 2.

The construction described above provides a simple and strong lock in which the key cannot be detached until the bolt is moved to the locking position, said lock being further fixed to the cycle or motorcycle so that it cannot be removed when the device is locked.

The dimensions and details of the device can vary according to requirements. The keyhole 16 can be of such irregular shape that only the proper key will pass there-through. The device can be constructed so as to be used either on the right or on the left hand side of the cycle or motorcycle, and that part of the bolt 3 which protrudes from the casing during the locking operation may be situated either at the upper part or at the lower part of the lock. As aforesaid locking is effected preferably on the spoke nipple 5 but can also be produced on the spoke itself, or the bolt can pass between two spokes. The bolt could also be so arranged as to act on the rim of the wheel to lock same.

What I claim as my invention and desire to secure by Letters Patent of the United States is:—

In a cycle lock, the combination with a casing, of a slidable bolt therein having a longitudinal recess terminating at its inner end in a circular enlargement, said bolt having at its opposite end a bifurcation to embrace a member on a cycle, a screw having a polygonal portion engaging the straight walls of said recess and engageable in said

curved enlargement, a curved clip member secured at one end to the casing, and an angular clip member cooperating therewith and adjustably connected with the casing
 5 by said screw, said recess preventing the turning of said screw when the bolt is in its locking position.

In witness whereof I have signed this specification in the presence of two witnesses.

FERDINAND GROLÉAS.

Witnesses:

GASTON JEAUNIAUX,
 THOMAS N. BROWNE.

Copies of this patent may be obtained for five cents each, by addressing the "Commissioner of Patents, Washington, D. C."
