

(12) STANDARD PATENT
(19) AUSTRALIAN PATENT OFFICE

(11) Application No. **AU 2019338073 B2**

(54) Title
Device and method for detecting railway equipment defects

(51) International Patent Classification(s)
B61L 23/04 (2006.01) **B61L 25/02** (2006.01)
B61K 9/08 (2006.01)

(21) Application No: **2019338073** (22) Date of Filing: **2019.09.02**

(87) WIPO No: **WO20/053699**

(30) Priority Data

(31) Number	(32) Date	(33) Country
102018000008445	2018.09.10	IT

(43) Publication Date: **2020.03.19**

(44) Accepted Journal Date: **2021.08.19**

(71) Applicant(s)
Mer Mec S.p.A.

(72) Inventor(s)
PERTOSA, Vito

(74) Agent / Attorney
Baxter Patent Attorneys Pty Ltd, Suite 2, Level 3A 1 Bligh Street, Sydney, NSW, 2000, AU

(56) Related Art
US 20070217670 A1
US 20140277824 A1



(51) International Patent Classification:

B61L 23/04 (2006.01) *B61L 25/02* (2006.01)
B61K 9/08 (2006.01)

(21) International Application Number:

PCT/IB2019/057378

(22) International Filing Date:

02 September 2019 (02.09.2019)

(25) Filing Language:

Italian

(26) Publication Language:

English

(30) Priority Data:

102018000008445 10 September 2018 (10.09.2018) IT

(71) Applicant: **MER MEC S.P.A.** [IT/IT]; Via Oberdan, 70,
70043 Monopoli (BA) (IT).

(72) Inventor: **PERTOSA, Vito**; c/o Mer Mec S.p.A., Via
Oberdan, 70, 70043 Monopoli (BA) (IT).

(74) Agent: **CONVERSANO, Gabriele**; Laforgia Bruni &
Partners Srl, Via Garruba, 3, 70122 Bari (IT).

(81) Designated States (unless otherwise indicated, for every

kind of national protection available): AE, AG, AL, AM, AO, AT, AU, AZ, BA, BB, BG, BH, BN, BR, BW, BY, BZ, CA, CH, CL, CN, CO, CR, CU, CZ, DE, DJ, DK, DM, DO, DZ, EC, EE, EG, ES, FI, GB, GD, GE, GH, GM, GT, HN, HR, HU, ID, IL, IN, IR, IS, JO, JP, KE, KG, KH, KN, KP, KR, KW, KZ, LA, LC, LK, LR, LS, LU, LY, MA, MD, ME, MG, MK, MN, MW, MX, MY, MZ, NA, NG, NI, NO, NZ, OM, PA, PE, PG, PH, PL, PT, QA, RO, RS, RU, RW, SA, SC, SD, SE, SG, SK, SL, SM, ST, SV, SY, TH, TJ, TM, TN, TR, TT, TZ, UA, UG, US, UZ, VC, VN, ZA, ZM, ZW.

(84) Designated States (unless otherwise indicated, for every

kind of regional protection available): ARIPO (BW, GH, GM, KE, LR, LS, MW, MZ, NA, RW, SD, SL, ST, SZ, TZ, UG, ZM, ZW), Eurasian (AM, AZ, BY, KG, KZ, RU, TJ, TM), European (AL, AT, BE, BG, CH, CY, CZ, DE, DK, EE, ES, FI, FR, GB, GR, HR, HU, IE, IS, IT, LT, LU, LV, MC, MK, MT, NL, NO, PL, PT, RO, RS, SE, SI, SK, SM, TR), OAPI (BF, BJ, CF, CG, CI, CM, GA, GN, GQ, GW, KM, ML, MR, NE, SN, TD, TG).

(54) Title: DEVICE AND METHOD FOR DETECTING RAILWAY EQUIPMENT DEFECTS

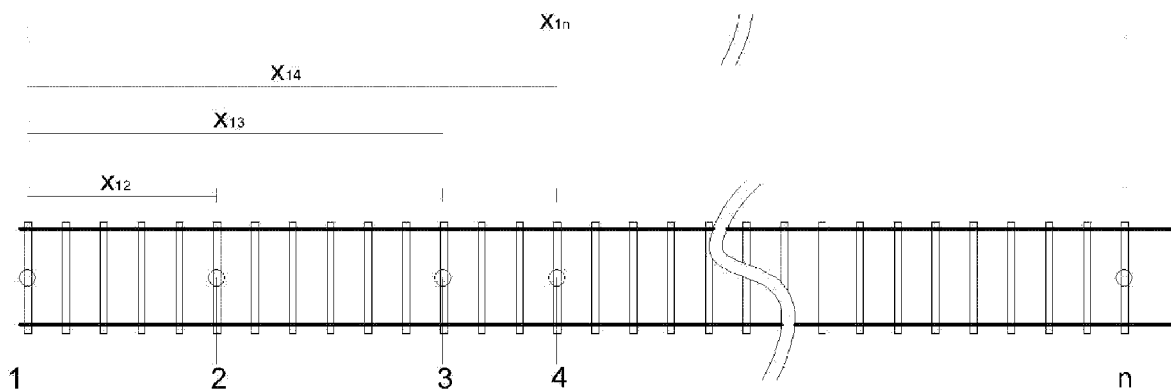

Fig 1

(57) Abstract: Device for detecting railway equipment defects, comprising at least three diagnostic modules mounted on a generic railway vehicle: a first module (geometrical module) configured to measure at least a geometrical feature of the track; a second module (acceleration module) configured to measure in at least a point of said vehicle the side and/or vertical accelerations transmitted from the track to said vehicle; a third module (visual module) configured to acquire the images of the track elements and to analyze them to verify the presence of anomalies; said modules being configured to associate with each detection carried out when the railway vehicle passes, on which they are mounted, the position where the detection was carried out and to calculate, for each detection, a severity index representative of the deviation of the detection with respect to the standard condition without defects.



Published:

- *with international search report (Art. 21(3))*
- *in black and white; the international application as filed contained color or greyscale and is available for download from PATENTSCOPE*

DEVICE AND METHOD FOR DETECTING RAILWAY EQUIPMENT DEFECTS

Object of the present invention is a device and method for detecting railway equipment defects.

5 State of the art

As it is known, railway equipment comprises tracks, any kind of railroad switches, ballast and anything needed for mounting, fixing and adjusting the railroad over which trains pass. It is also known
10 that railway equipment defects represent a danger for circulating trains, since they can cause running instability and derailment in the worst cases.

The severity of a defect is linked to the capacity
15 of the same defect to cause in the vehicle anomalous vertical and transversal accelerations which can lead to the vehicle derailment.

The defects which can transmit anomalous accelerations to a railway vehicle are for example
20 track geometrical defects detected for parameters as track twist, alignment, longitudinal level.

Other defects are cracks on sleepers, coupling tools anomalies, anomalies of joints (including the isolated, glued ones), insufficient crushed stone
25 for ballast, absence or loosening of sleeper screws for sleepers and track bolts for joints.

Therefore, it is particularly important to detect defects and to evaluate their severity, i.e. the probability they cause a derailment.

In order to detect railway equipment defects there
5 have been realized and are known at the state of the art a plurality of measuring and control systems which, mounted on railway vehicles, allow to detect the just described railway equipment defects.

10 Moreover, the causes of the just described defects can be various and so, individuating a defect is not enough to individuate univocally its cause. As a way of example, geometrical defects can be caused by: ballast yielding, isolated joints yielding,
15 sleepers braking, deterioration or absence of coupling tools between rail and sleeper.

It is clear that it is possible to plan a correct maintenance operation only knowing the defect cause. Therefore, another problem, strictly linked
20 to the defect detection and severity evaluation is the individuation of their causes, so that they can be removed by suitable maintenance operations and they are prevented from occurring again.

As all the measuring systems, also the railway
25 diagnostics systems suffer from errors and so from false positives, which mean that a severe defect is

detected when instead it is absent, or it is not so severe. It is to be specified that, according to what known at the state of the art, the defect severity index is evaluated as a function of the
5 comparison between the values of the critical parameters monitored by the diagnostic systems and the relative critical thresholds which can define one or more severity indexes.

However, this conceptually simple enough approach
10 has some limits. *In primis*, the comparison of a parameter value with a threshold value does not allow to consider the synergic effect of a plurality of defects, also of different kind, localized close to each other: even if the presence
15 of a single defect characterized by a parameter, whose value is under the relative threshold, guarantees the vehicle running safety, the concomitance of more close defects can increase dangerously the whole severity index for running
20 trains, even if the severity index of the single defects is kept under the threshold value.

In some cases, this consideration leads to use in the systems known at the state of the art very preventive threshold values, while in other cases
25 the synergic effect of more defects is simply not

considered, thus creating a danger condition for the train circulation.

Therefore, the percentage of false positives with respect to real defects is often high and
5 economically unacceptable, since it compels operators to further work to verify the detected defects or not.

Moreover, it is just for this approach aiming at the individuation of the single defect that the
10 diagnostic systems known at the state of the art are limited to defects detection and measurement, without automatically determining their cause.

A first example of device known at the state of the art is described in DE19801311, where it is
15 described a railway maintenance vehicle comprising a plurality of diagnostic modules arranged in various parts of the vehicle, in which various features of the railway equipment are analyzed in order to evaluate their influence on a defect of
20 the railway equipment. DE19801311 suggests comparing each measured variable with a respective predetermined threshold. Moreover, it is indicated to normalize the position of each acquisition of parameters carried out by each diagnostic tool with
25 respect to the center of the vehicle, so that maintenance per kilometer reports can be made.

In the system described in DE19801311 the provision of many sensors allows to determine a cause-effect relation between various close defects: for example a defect on the overhead cable can be generated by
5 a geometrical defect of the track which generates an anomalous attitude of the vehicle, and so, of the pantograph which then wears out the overhead cable anomalously. So, DE19801311 suggest investigating the cause-effect relation between
10 different kinds of defects, to help the maintenance operator to carry out the correct maintenance operation.

In DE19801311, instead, there is no reference to the synergic effect which many close defects, also
15 moderate if considered singularly, can exert on the circulation safety. In fact, the threshold each defect is to be compared with is predetermined and does not depend on the presence or absence of other close defects of any kind.

20 Another example is described in US2007/217670, where it is described a railway vehicle provided with a video acquisition system configured to record the track when the train passes and which is provided with an image processing software
25 configured to detect the irregularities and to compare each irregularity with the defects

predefined in the defect benchmark library. If the irregularity is equal or exceeds a safety threshold, the image is assigned a code of the defect kind. The image of the irregularity is then
5 transmitted to be analyzed by a track expert.

Also in this case, regardless of many acquisition devices are provided on board of the vehicle or not, there are no indications of the fact that data deriving from the various acquisitions are used to
10 eliminate the false positives derived from each acquisition or to evaluate the severity of each defect in its context (i.e. more or less close to other defects).

Yet, another example is described in EP33333043, in
15 which it is described a detection method in which with each defect is associated a severity index calculated by assigning weights to the different features of the same defect: for example, defect length, position on head and shank of the rail,
20 transit frequency on that point. So, also in this case, the severity index does not calculate the synergic effect on the vehicle dynamics of many close defects.

Technical problem

25 As it can be noted, in all the cited embodiments, the railway vehicles are provided with a plurality

of diagnostic tools, but the severity of each defect is evaluated singularly, by comparison it with a safety threshold. At the most, it is investigated the cause-effect relation between many
5 defects occurred in the same point.

However, this approach has a series of limits: *in primis*, if the safety threshold, which is fixed for each defect, is very high, potentially dangerous defects can be ignored, while if to obviate this
10 problem the safety threshold is lowered, "false positives" can be detected, i.e. anomalies taken for defects; *in secundis*, the same fact to fix a predetermined safety threshold with which to compare the acquired parameters for each defect
15 leads to the impossibility to evaluate, when deciding the defect severity, its position with respect to the other defects (whether of the same kind or not).

Therefore, there remains unsolved the problem to
20 provide a device which can be mounted on railway vehicles and a method for analyzing the data detected by such device, which allow to detect the defects of the equipment, thus exceeding the embodiments known at the state of the art.

25 In particular, it is unsolved the problem to provide an analysis method of data detected by a

plurality of diagnostic devices of the railway equipment, mounted on board of the vehicle, which uses the acquired data in order to avoid the detection of false positives, as well as in order
5 to evaluate the synergic effect on circulation safety due to consecutive defects.

Aim of the invention

Aim of the present invention is to provide a device which can be mounted on railway vehicles configured
10 so that it is possible to detect at the same time and automatically a plurality of different kinds of possible defects of the railway equipment and their severity index, and a method for analyzing data measured by means of such device which allows to
15 obtain more accurate evaluations of the defects severity than the ones possible by using the systems known at the state of the art.

According to another aim, the object of the present invention provides a device and a method which
20 allow both to reduce the quantity of false positives detected and to consider the synergic effect of moderate defects.

Yet, another aim of the present invention is to provide a device and a method for analyzing data
25 which allow to associate with the defects detected

the cause of the same and to plan consequently the correct maintenance operation.

Brief description of the invention

The invention realizes the prefixed aims since it
5 is a device for detecting railway equipment defects, comprising at least three diagnostic modules mounted on a generic railway vehicle:

- a first module (geometrical module) configured to measure at least a geometrical feature of the
10 track;

- a second module (acceleration module) configured to measure in at least a point of said vehicle the side and/or vertical accelerations transmitted from the track to said vehicle;

15 - a third module (visual module) configured to acquire the images of the track elements and to analyze them to verify the presence of anomalies;

said modules being configured to associate with each detection carried out when the railway vehicle
20 passes, on which they are mounted, the position where the detection was carried out and to calculate, for each detection, a severity index representative of the deviation of the detection with respect to the standard condition without
25 defects.

Detailed description of the invention

According to a preferred embodiment, the system according to the present invention comprises at least three diagnostic modules mounted on a generic railway vehicle:

- 5 - a first module, called geometrical module, dedicated to measuring track geometrical parameters (rail gauge, superelevation, alignment, longitudinal level, track twist or any other parameter derived from geometrical measures on
10 track);
- a second module, called acceleration module, dedicated to measuring side and vertical accelerations transmitted from track to measuring vehicle;
- 15 - a third module, called visual module, configured to acquire images of the track elements and to analyze them automatically to detect visual defects, for example absence or anomalies of couplings, joints anomalies, insufficient quantity
20 of crushed stones, absence or loosening of sleeper screws for sleepers and track blots for joints.

The three modules are configured to associate with each detection of a potential defect carried out when the railway vehicle passes, on which they are
25 mounted, the position where such detection was

carried out. This association can be carried out by means of a GPS signal and/or an odometer.

The three modules are also configured to calculate, for each detection, an index representative of the deviation of the detection with respect to the standard condition without defects, in the following also called severity index (h_i).

The diagnostic method for detecting railway equipment defects which can be applied with the device according to the present invention comprises the following steps of:

- a) measuring geometrical, accelerometric and visual parameters at the same time, by means of the just described three diagnostic modules;
- b) evaluation of the severity index calculated for all the detections, in order to detect potential defects, by associating with each potential defect the position where it was detected;
- c) comparison of said severity index with at least a predetermined critical threshold for defect kind.

The method is characterized in that it further comprises:

- e) another analysis for
 - (i) verifying the detected defect, thus excluding that it is a false positive;
 - (ii) determining the cause of the defect;

(iii) verifying if a defect, even if the severity index is lower than the threshold of step d), is to be considered dangerous since it is close to other defects.

5 As a function of the results of the analysis of point e), therefore, it is possible to determine the kind of maintenance to be carried out to restore the normal conditions of the equipment in a more efficient and exact way with respect to the
10 known systems.

Examples of application

In the following, some examples of application of the just described method are reported for clarity's sake.

15 A partial deterioration of an isolated joint determines a localized yielding of the rail under load, which causes an anomalous acceleration of the vehicle. In such condition, the geometrical module detects a level defect (gap between rail height and
20 surrounding rolling plane), while the acceleration module detects an anomalous vertical acceleration at the vehicle axles. The visual module, at the same measuring section, recognizes the presence of a joint and detects there a fracture which reduced
25 its structural stiffness.

The concomitance of these three detections (geometrical, accelerometric, visual) allows to verify the defect, thus excluding that it is a false positive.

5 This redundancy, i.e. the presence of systems measuring many physical aspects, allows a cross check of the defect detection which reduces the error probability, thus allowing a global evaluation of the risk condition, a reduction of
10 false positives, and the determination of the cause determining the defect.

On the basis of the information provided by the system, from the point of view of the maintenance operator, it is clear that the joint is to be
15 repaired or changed, and the correct maintenance operation allows to plan the maintenance operation in a more efficient and economical way, thus avoiding the worsening of the detected condition. In fact, anomalous yielding of the joint leads to
20 high accelerations transmitted from vehicle to track; such accelerations cause ballast yielding, thus further increasing the joint inflection.

If the system detects in the same measuring section absence of crushed stone as well, the maintenance
25 operator will know in advance, i.e. before going physically on place, that in addition to the

substitution of the joint, it is to be restored also the ballast original profile.

The further analysis, which can be carried out with the system according to the invention, provided
 5 with the information about defects presence, kind, severity and position, is the definition of an index which, in addition to the single defect severity, considers also their mutual position.

It is to be indicated with:

- 10 - d_1, d_2, \dots, d_n a number n of consecutive defects, each one of any different kind, detected by the running railway vehicle;
- $x_{12}, x_{13}, x_{14}, \dots$, the distance between a defect and the following ones in running direction;
- 15 - h_1, h_2, \dots, h_n the severity index of each defect considered isolated.

It is to be specified that the parameter "d" contains a coding of the defect kind.

The method according to the present invention, in
 20 order to carry out an analysis of the synergic action of many isolated defects, provides the calculation of a global severity index h_t of the detected defects, as a function of the kind and severity of each defect, as well as of its relative
 25 distance with respect to the other defects.

$$h_t = F(d_i, h_i, x_{ij}) \quad (1)$$

According to a first embodiment, the function F is a linear or not linear combination of the parameters; according to another embodiment the function F is a Fuzzy logarithm or any other
 5 mathematical function which allows to combine efficiently the defects synergic effect.

As a way of example, assuming that a defect d_1 was detected with severity index h_1 , and assuming also that a second defect d_2 was detected with severity
 10 index h_2 at distance x_{12} from the first defect, a possible mathematical function calculating the total severity index of the two aggregated defects is the following:

$$h_t = h_1 + \left(e^{-\frac{x_{12}}{a_{12}}} \right) \cdot h_2 \quad (2)$$

15 The term in parenthesis is a decreasing exponential function which weighs the contribution of defect d_2 aggregated to defect d_1 . If the two defects are present in the same track section, their inter-distance x_{12} is equal to zero, and so the term in
 20 parenthesis is equal to 1. Therefore, the effect of defect d_2 aggregated to defect d_1 is considered completely in the calculation of the combined severity index h_t . While the inter-distance increases, the exponential reduces to zero as
 25 faster as lower the amplification coefficient a_{12}

is. This coefficient quantifies the synergic effect of the distance between two aggregated defects; therefore, it will be higher when the synergic effect of the second defect vanishes rapidly with
5 the distance.

As a way of merely indicative and not limiting example, in the following it is described an embodiment of the method. Let's assume to evaluate the severity index (h_1) of a defect according to a
10 scale from 1 to 5, in which:

- value 1 of the index corresponds to a moderate defect which does not require any specific action other than to monitor its evolution in time;
- value 2 corresponds to the need of a maintenance
15 operation in three months;
- value 3 corresponds to the need of a maintenance operation in a week;
- value 4 corresponds to the need of a maintenance operation in a day;
- 20 - value 5 corresponds to a very severe defect which requires the suspension of the train circulation and the immediate elimination of the defect.

It is to be considered now the rail gauge measure, whose nominal value is 1435 mm. According to the
25 just described logic, when the system measures in a determined point of the track a rail gauge value

equal to 1440 mm it generates a defect with severity index equal to $h_1 = 1$, since a deviation of 5 mm is not considered severe with respect to the nominal measure. In order to explain better the logic, if in the same point a rail gauge value equal to 1465 mm is measured, the same defect would be assigned a value equal to 4 of the severity index, which would require a maintenance operation in 24 hours.

10 Let's assume now that at a distance $x_{12} = 0,5$ m with respect to the point where it was generated the defect with severity index equal to 1, the visual system detects the absence of both bolts on inner and outer couplings of the right rail.

15 This second defect, taken singularly, is assigned a severity index $h_2=2$, which means a maintenance operation in three months.

However, the close distance between the two defects allows to foresee a possible increase in rail gauge in short time, owing to the absence of two bolts on the right rail, but this defects evolution, even if technically foreseeable, is not signaled by the detection systems known at the state of the art, which consider the defects singularly. Therefore, in case of using one of any system known at the state of the art, maintenance operations would be

undertaken in three months, thus allowing the rail gauge defect to evolve towards a condition of greater risk for circulation.

The system according to the present invention instead, by providing the calculation of the total severity index according to what previously explained, even in presence of defects, which are not considered severe singularly, indicates the need of a more imminent maintenance operation.

10 In fact, by assuming an amplification ratio $a_{12}=2$ for combined presence of a defect kind $d_1 =$ rail gauge defect and a defect kind $d_2 =$ absence of couplings, the calculation of the total severity index would be obtained with the yet reported
 15 formula (2), which, in this case, would give the following value:

$$h_t = h_1 + \left(e^{-\frac{h_1}{a_{12}}} \right) \cdot h_2 = 1 + \left(e^{-\frac{0,5}{2}} \right) \cdot 2 = 2,56 \rightarrow 3$$

The calculated value h_t , since it is greater than 2,5, is rounded up to 3, and so, according to the
 20 just described severity scale, is it determined the need for a maintenance operation in a week.

Therefore, it is observed as the presence of two close defects which, taken singularly, would indicate the need of a maintenance operation in
 25 three months, is detected by the system according

to the present invention as a defect which requires a maintenance operation in a week.

In the case of the just explained example, this reduces drastically the evolution of rail gauge
5 defect. However, it is clear that what just described is only an example of the method according to the invention, and that different numerical values can be assigned to amplification factors or to severity indexes, without departing
10 from the aims of the invention.

CLAIMS

1. Device for detecting railway equipment defects,
comprising:
- at least three diagnostic modules mounted on a
5 generic railway vehicle, of which:
 - a first module (geometrical module) is
configured to measure at least a
geometrical feature of the railway;
 - a second module (acceleration module) is
10 configured to measure in at least a point
of said vehicle the lateral and/or
vertical accelerations transmitted from
the railway to said vehicle;
 - a third module (visual module) is
15 configured to acquire images of railway
elements and to analyze them to verify the
presence of anomalies;
 - means for detecting the position of the railway
vehicle;
 - 20 - electronical means configured to acquire data
detected by said diagnostic modules and to
calculate, for each detection carried out by each
module, a severity index representative of the
deviation of the detection with respect to the
25 standard condition of the railway without
defects,

characterized in that said electronic means are configured to:

- a) calculate for each detection of each module an initial severity index (h_1) indicative of the amplitude of the deviation of the detection with respect to the standard condition without defects;
- b) associate to each initial severity index (h_1) a parameter (d_1) indicative of the kind of potential defect;
- c) associate each initial severity index (h_1) and respective parameter (d_1) indicative of the kind of potential defect with their acquisition position (x_i), thus defining a potential defect characterized by: a position (x_i), a kind parameter (d_1) and an initial severity index (h_1);
- d) calculate for each potential defect defined in point c) a global severity index (h_t), as a function of said parameter (d_1) indicative of the kind, of said initial severity index (h_1), and of the relative distances (x_{ij}) with respect to other detected potential defects, of their kind parameters and of their initial severity index;
- d) compare said global severity index (h_t) with a critical threshold to determine if said potential defect needs a maintenance operation or not.

2. Device for detecting railway equipment defects according to claim 1, characterized in that said global severity index (h_t) is given by the sum of:

- said initial severity index (h_i) and of

- 5 - a contribution relative to each potential defect detected in a predefined area close to said position (x_i) of said defect for which the global severity index (h_t) is calculated.

- 10 3. Device for detecting railway equipment defects according to claim 2, characterized in that said contribution relative to each potential defect (h_j) detected in a predefined area close to said detection position (x_i) of said defect for which the
- 15 global severity index (h_t) is calculated is given by the product of the severity index (h_j) of said potential defect multiplied by a term which is a function of the relative distance of said two defects (x_{ij}) and of said kind parameters of the two
- 20 defects (d_i, d_j).

4. Device for detecting railway equipment defects according to claim 2 or 3, characterized in that said term function of the relative distance of said
- 25 two defects (x_{ij}) and of said kind parameters of the two defects (d_i, d_j) is calculated as negative

exponential of the ratio between the distance of the two defects (x_{ij}) and an amplification coefficient (a_{ij}), function of said kind parameters of the two defects.

5

5. Device for detecting railway equipment defects according to any one of the preceding claims, characterized in that said critical threshold depends on said kind parameter.

10

6. Device for detecting railway equipment defects according to any one of claims 2 to 5, characterized in that width of said predefined area is 1 km.

15

7. Device for detecting railway equipment defects according to any one of the preceding claims, wherein said geometrical parameters comprise at least a parameter selected among: rail gauge,
20 superelevation, alignment, longitudinal level, track twist or any other parameter derived from geometrical measures on the rail.

25

8. Device for detecting railway equipment defects according to claim 1 or 2, wherein said visual anomalies detected by means of said visual module

comprise at least an anomaly selected among:
absence or anomaly of couplings, joints anomaly,
insufficient quantity of crushed stone, absence or
loosening of sleeper screws for sleepers and track
5 bolts for joints, presence of fractures on sleepers
and rails or any other morphological anomaly of the
elements constituting the equipment.

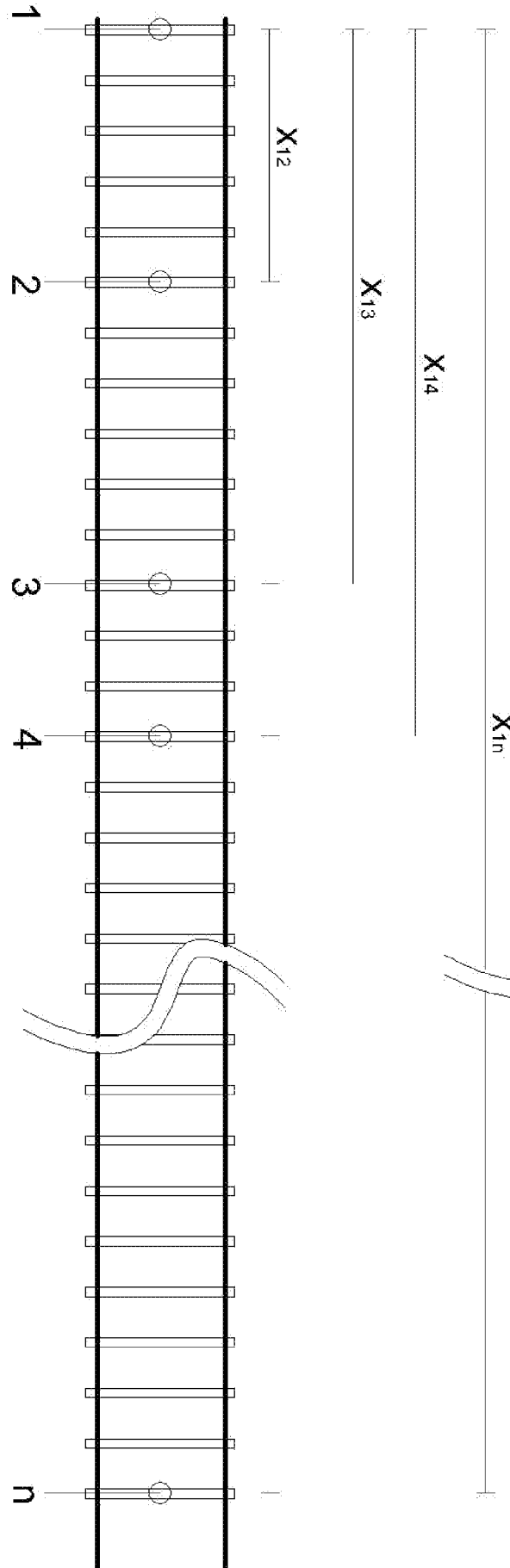

Fig. 1