

Feb. 9, 1954

H. L. GIESZL

2,668,330

CLEANER FOR MECHANICAL COTTON PICKERS

Filed Feb. 25, 1952

2 Sheets-Sheet 1

FIG. 1.

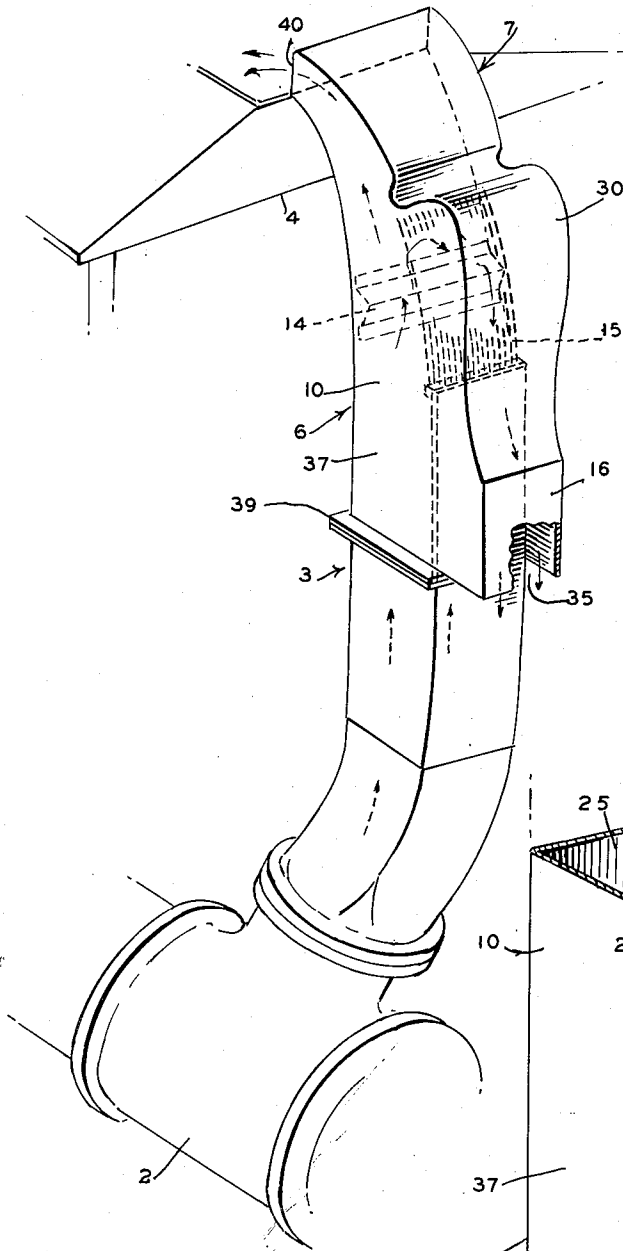
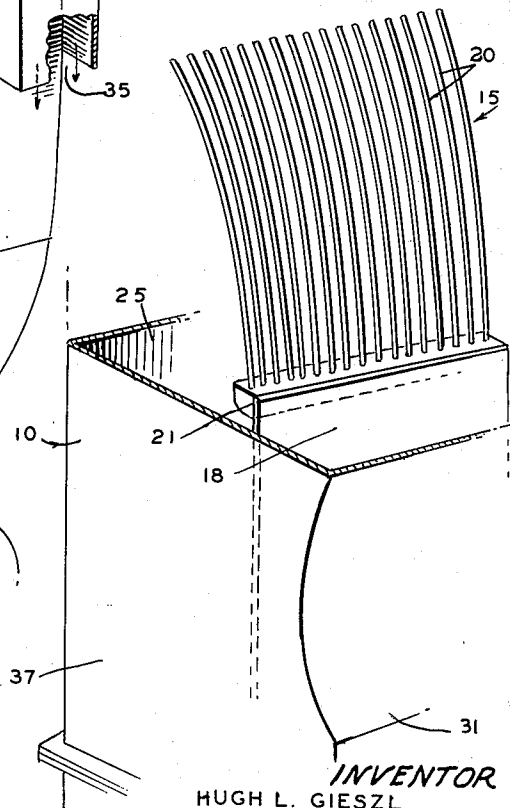

FIG. 4.



INVENTOR
HUGH L. GIESZL
BY *Scott & Howie*
ATTORNEY

Feb. 9, 1954

H. L. GIESZL

2,668,330

CLEANER FOR MECHANICAL COTTON PICKERS

Filed Feb. 25, 1952

2 Sheets-Sheet 2

FIG. 3.

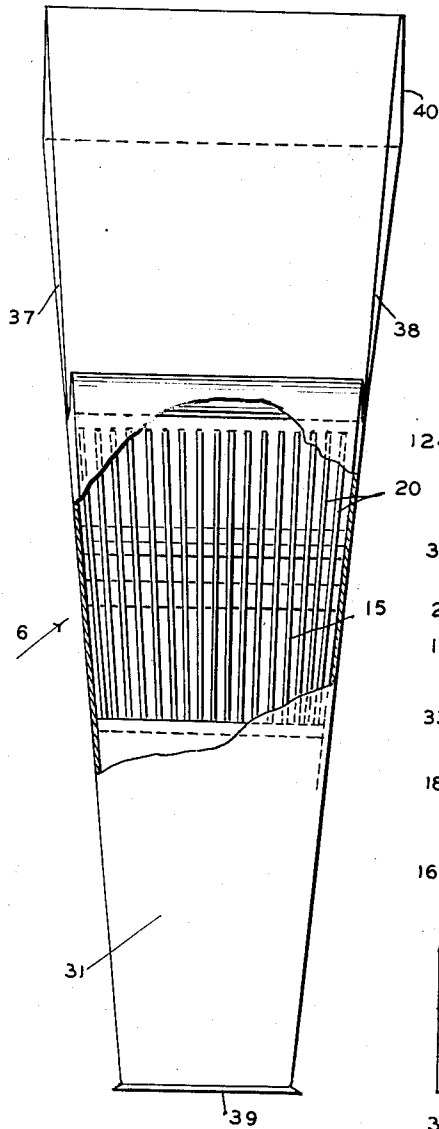
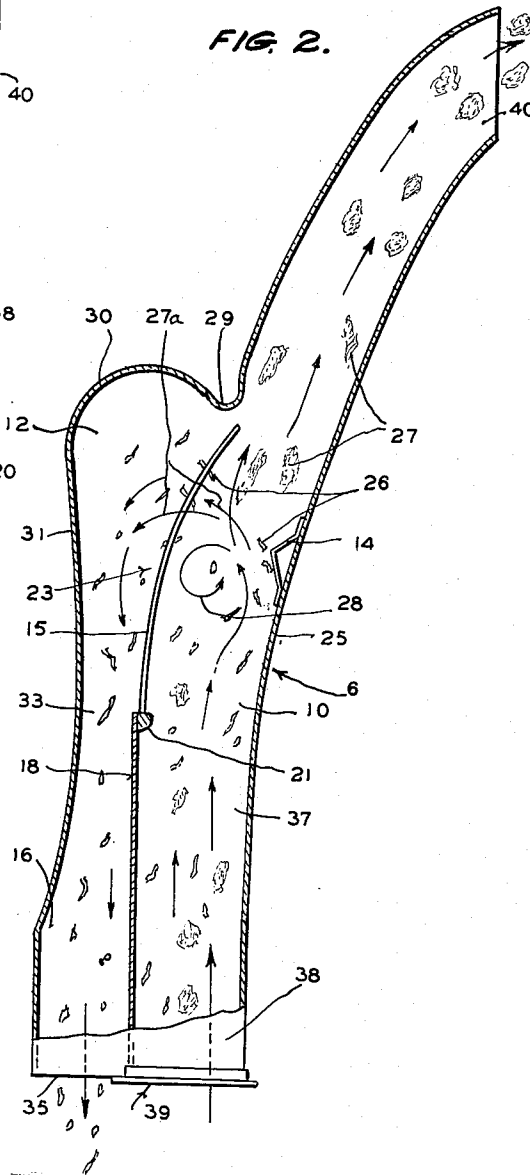

FIG. 2.



INVENTOR
HUGH L. GIESZL

BY *Scott L. Maxwell*
ATTORNEY

UNITED STATES PATENT OFFICE

2,668,330

CLEANER FOR MECHANICAL COTTON PICKERS

Hugh L. Gieszl, Gilbert, Ariz.

Application February 25, 1952, Serial No. 273,273

4 Claims. (Cl. 19-76)

1

This invention concerns cleaners for mechanical cotton pickers.

It is well known that many mechanical cotton pickers gather, along with the cotton, an excessive amount of dirt, leaves, dried fragments of bolls, and stems. This lowers the grade of the cotton and makes it necessary for the gin to put the cotton through an extra cleaning process, the cost of which is deducted from the price of the cotton delivered at the gin.

While cotton may be cleaned after it has been transported to the gin it is harder to clean at this time because the dirt has been worked into it during handling and transportation and has become broken into small pieces and enmeshed throughout the cotton fibers. It is much more desirable to remove the dirt immediately after picking and before the cotton enters the receiving cage of the picker.

In view of the foregoing, one of the objects of my invention is to provide a cleaner which may be installed in the delivery duct of a mechanical cotton picker wherein the cotton is conveyed from the picker spindles to the cage by a current of air;

A second object is to provide a cleaner for a picker of the type described wherein the dirt and trash is separated from the cotton before the cotton enters the receiving cage;

A third object is to provide a cleaner of the type above mentioned which will separate dirt and trash from cotton blown through a duct to the receiving cage, by use of the air currents flowing through the duct and without the use of mechanism driven separately from the blower of the picker.

Other objects will appear hereinafter.

I attain the foregoing objects by means of the structure devices and combinations of parts shown in the accompanying drawings, in which

Figure 1 is a perspective view of the cleaner as applied to the cotton delivery duct of a mechanical cotton picker;

Figure 2 is a sectional side elevation thereof;

Figure 3 is a front elevational view of the cleaner with parts of the outer covering broken away to show the interior; and

Figure 4 is a perspective view of the cleaning grid.

Similar numerals refer to similar parts in the several views.

Air with cotton tufts entrained together with a certain amount of trash, is drawn from the picking mechanism (not shown) by blower 2 and forced from blower outlet 3. The cleaner body 6

2

extends from the upper end of outlet 3 to cotton receiving cage 4, as shown in Figure 1.

The cleaner 6 consists, in general, of a duct 10 having its lower end joined to blower outlet 3 and its upper discharge outlet joined to cage 4, a low pressure chamber 12, a deflecting and turbulating baffle 14, a vibratable grid 15, covering a trash escape opening, and a trash removal duct 16.

More particularly, the body 6 of which includes duct 10 extends upward from its lower end to a position in its upper portion and then bends at curve 7 to form a short horizontal upper portion which terminates at outlet 40 and opens into cage 4.

Just below the bend 7 a trash escape opening 23 is formed in the composite outer wall of duct 10. Below this opening the outer wall of the duct 10 is formed by plate 18 which also acts as a separation plate between the lower portion of duct 10 and the trash removal duct 16. Above this opening the outer wall plate 31 of body 6 forms the outer wall of duct 10.

The upper edge of trash escape opening 23 is formed by a sharp outward bend 29 in outer wall plate 31 of the body 6. The lower edge of this opening is formed by the upper edge of plate 18. The back portion of duct 10 is enclosed by back wall plate 25 of body 6. The back and outer walls of cleaner body 6 are joined at their lateral edges by side wall plates 37 and 38. The entire duct has a substantially rectangular section. The vertically extending lower portion, however, is nearly square while the short horizontally extending upper portion has a wide transversely extending rectangular section.

Opening 23 is covered by a grid 15. Grid 15 consists of a number of stiff wires 20 set into a transverse base member 21 which is attached to the top edge of separating plate 18. Wires 20 are evenly spaced and extend upward in substantially mutually parallel relation to approximately the top of opening 23. These grid wires are curved longitudinally to extend approximately parallel to the longitudinally curved opposite portion of back wall plate 25. Their upper ends extend inward, somewhat from the upper edge of opening 23. Otherwise, laterally, the grid wires are straight. As seen in elevation, in Figure 3, they fan out slightly toward their upper ends due to the fact that duct 10 widens laterally as it approaches its outlet 40.

Opening 23 connects duct 10 to low pressure chamber 12 and is formed by an outwardly rounded hump 30 in the outer wall 31 just beyond and below bend 29. This wall portion ex-

tends downward from hump 30 somewhat parallel to the plane of plate 18, but at about the bottom of opening 23 it curves inward and outward again forming a Venturi throat 33. The trash outlet duct 16, formed between plates 31 and 18, then extends downward to trash vent 35 where it opens to the atmosphere.

A humped V-shaped baffle 14 is attached to back wall 25 of duct 10 slightly above the central portion of opening 23. Its purpose is to deflect air and entrained particles of trash 26 toward opening 23 and toward grid 15. The deflection of the air, as indicated by arrows 21a, causes a turbulence indicated by arrows 28 which breaks the velocity of the particles of trash 26, but does not greatly affect the flow of lighter tufts of cotton 27.

In operation, the duct 10 is incorporated in the picking machine with the inlet 39 connected to the outlet 3 of the blower 2. Air, with entrained cotton and trash, is driven into duct 10 and the main body of the flow is forced through outlet 40 into the receiving cage 4. This outlet is restricted, however, so that an appreciable amount of air is forced through trash outlet opening 23. Some of this air enters the low pressure chamber 12 due to pressure differential, and some enters due to the inertia of flow caused by the turbulating baffle 14, and due to the fact that the opening is on the outside of the bend 7 of upper curved portion of the duct. As pressure from the air stream forces the air in the low pressure chamber 12 on out from the trash outlet duct 16 it passes through the Venturi throat 33 and increases in velocity. This is sufficient to quickly draw and induce any trash particles in the low pressure chamber into duct 16, and to force them from outlet 35.

The movement of air and trash particles from duct 10 to low-pressure chamber 12 is irregular and while trash particles may be thrown against the grid by the velocity of their movement through duct 10, as they curve around bend 7, their movement in low-pressure chamber is slow and they are inclined to eddy whirl about in the chamber. The increased velocity of the air in the Venturi throat 33 tends to quickly draw them out, however, so that they are forcefully expelled from outlet vent 35. If opening 23 were exposed directly to atmosphere the flow effective to eject trash would clog up the grid with cotton tufts. To be effective there must be an eddying action of varying pressures acting through the grid from duct 10 to chamber 12.

The spring rods of grid 15 are spaced sufficiently close to retain all tufts of cotton 27 within the duct 10, but are a sufficient distance apart to permit passage of trash particles 26. Since these particles are of irregular shapes, they are inclined, at times, to hang up on the grid wires. However, due to the vibration of the air from the blower and to the always present irregularities in air flow through the grid, these particles move from their place of lodgement and cause the rods of the grid to yield slightly and, thus permit them to pass into the low pressure chamber 12. During operation the rods of the grid vibrate, somewhat, at all times. They not only pick up vibration from the air stream, induced by the beating of the blower blades, but pick up vibration from the other parts of the picking machine. Since their upper ends are free no cotton is retained on them. All tufts that may be temporarily caught on the grid wires slide or roll off

the ends of the wires, and again enter the air stream in the duct 10.

It is to be understood that the action of the turbulating baffle is important in that it causes an eddy or turbulence 28 in the air stream in the duct. This momentarily slows the velocity of tufts of cotton containing trash, tends to spin them and to dislodge the trash, and decidedly slows the denser and heavier trash particles. At the same time the eddy tends to deposit them, or direct them toward grid 15.

From the foregoing it will be understood that I have provided an easily made and efficiently operating trash removal device which cleans the cotton as it comes directly from mechanical picker and before it has had a chance to become imbedded in the cotton bolls. This device can be easily installed in the duct which ordinarily goes from the blower to the receiving cage of many types of mechanical pickers. In a sense, the body 6 of the cleaner, including particularly duct 10, becomes a part of duct 3. It takes the place of the upper part of this duct and the upper part of duct 10 discharges thru outlet 40 directly into the cage 4.

After installation no further care is needed. The operation is automatic.

Whereas I have shown the preferred form of the device it is to be understood that I intend to claim the form herein illustrated and all mechanical substitutions of the several parts.

I claim:

1. In a mechanical cotton picking machine having a blower drawing a current of air, together with entrained cotton tufts and trash, from mechanical picking mechanism and forcing said air through said blower outlet, and a cotton receiving cage, a cotton cleaner for removing particles of trash included in said air current along with said cotton, including a duct having a composite outer wall and an inner wall, a vertically extending lower portion, with its lower end constituting an inlet and attached to the outlet of said blower, the upper portion being curved and terminating in a horizontally opening outlet connected to said cotton receiving cage, said composite outer wall having a trash outlet opening disposed at approximately the middle of its length; a grid covering said trash outlet opening consisting of substantially parallel, laterally spaced spring wires attached at their lower ends to the upper edge of said trash outlet opening and extending upward therefrom across said opening; and a trash outlet duct having a chamber at its upper end enclosing said trash outlet opening, and extending downward therefrom through a Venturi throat to a trash outlet vent; the outlet of said duct being appreciably constricted relative to its inlet so as to force a portion of the air from said blower through said trash outlet opening.

2. In a cotton picking machine having mechanical picking mechanism, a blower having an outlet drawing air with entrained cotton from said mechanical picking mechanism and a cotton receiving cage, a cotton cleaner consisting of a body including a duct, having a composite outer wall, a back wall, and side walls, formed with a vertically extending lower portion, an upper portion having a bend to form a horizontally extending outlet, opening into said receiving cage, an inlet at its lower end connected to the outlet of said blower; said composite outer wall having a trash outlet opening therein just below said bend; a low pressure chamber formed

5

on said outer wall of said body opposite the said trash outlet opening connected to a downwardly extending trash duct having an outlet, and a Venturi throat formed between said low pressure chamber and said outlet; a grid passing particles of trash but retaining cotton tufts covering the said trash outlet opening in the outer composite wall of said duct composed of a transverse row of spaced resilient wires extending vertically from a transverse bar, at the bottom of said opening, and a turbulating baffle disposed on the inner face of the back wall of said duct opposite the lower portion of said trash outlet opening, directing particles of trash toward said grid.

3. In a cotton picking machine having mechanical picking mechanism, a blower having an outlet drawing air with entrained cotton from said mechanical picking mechanism and a cotton receiving cage, a cotton cleaner consisting of a body including a duct, having a composite outer wall, a back wall, and side walls, formed with a vertically extending lower portion, an upper portion having a bend to form a horizontally extending outlet, opening into said receiving cage, an inlet at its lower end connected to the outlet of said blower; said composite outer wall having a trash outlet opening therein just below said bend; a low pressure chamber formed on said outer wall of said body opposite the said trash outlet opening connected to a downwardly extending trash duct having an outlet, and a Venturi throat formed between said low pressure chamber and said outlet; a grid passing particles of trash but retaining cotton tufts covering the said trash outlet opening in the outer composite wall of said duct composed of a transverse row of spaced resilient wires extending vertically from a transverse bar, at the bottom of said opening, and a turbulating baffle disposed on the inner face of the back wall of said duct opposite the lower portion of said trash outlet opening, directing particles of trash toward said grid; said duct having its outlet constricted relative to its inlet forcing a portion of air passing therethrough into said trash outlet.

4. In a cotton picking machine having mechanical picking mechanism, a blower having an outlet drawing air with entrained cotton from

6

said mechanical picking mechanism and a cotton receiving cage, a cotton cleaner consisting of a body having a vertical lower portion and a horizontal upper portion joined thereto by an angular bend having a back wall and an outer wall joined by side walls, a separation plate in the lower portion of said body dividing it and forming the outer wall of the lower portion of an air and cotton duct adjacent said back wall and a trash outlet duct adjacent the outer wall of said body, an air and entrained cotton duct extending through said body enclosed on the inside by the back wall of said body and on the outside by a composite outer wall including said separating plate and the upper portion of the outer wall of said body; an inlet at the lower end of said air and cotton duct connected to the outlet of said blower, and an outlet at the end of said horizontal portion of said body connecting to said cotton receiving cage; the outer wall of said body having a sharp outward bend at the lower end of said angular bend of said body, followed by a downward curve forming a low pressure chamber; said composite outer wall of said duct having a trash outlet opening extending between the outward bend in the outer wall of said body and the top of said separation plate connecting said air duct with said low pressure chamber; a grid covering said outlet opening formed of spaced vertically extending spring wires attached to the upper edge of said separation plate; a baffle attached to the inner face of the back wall of said duct directing air toward said trash outlet opening and causing turbulence of air flowing through said air duct; said trash outlet duct having a bottom outlet vent, and an intermediate Venturi throat opposite the bottom edge of said trash outlet opening.

HUGH L. GIESZL.

References Cited in the file of this patent

UNITED STATES PATENTS

Number	Name	Date
268,209	Engram	Nov. 28, 1882
1,002,131	Broome	Aug. 29, 1911
1,042,394	Cheesman	Oct. 29, 1912
2,214,680	Sims	Sept. 10, 1940