





**EUROPEAN PATENT APPLICATION**

 Application number: 84200212.3

 Int. Cl.<sup>3</sup>: **A 47 F 5/13**  
**A 47 B 57/12**

 Date of filing: 17.02.84

 Priority: 10.03.83 IT 3483983 U

 Date of publication of application:  
 19.09.84 Bulletin 84/38

 Designated Contracting States:  
 AT BE CH DE FR GB LI LU NL SE

 Applicant: **Pressanto, Alfredo**  
**87, Via Mantova**  
**I-43100 Parma(IT)**

 Inventor: **Pressanto, Alfredo**  
**87, Via Mantova**  
**I-43100 Parma(IT)**

 Representative: **Corradini, Corrado**  
**4, Via Dante Alighieri**  
**I-42100 Reggio Emilia(IT)**

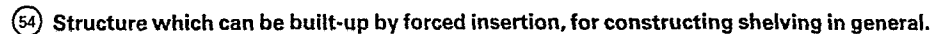

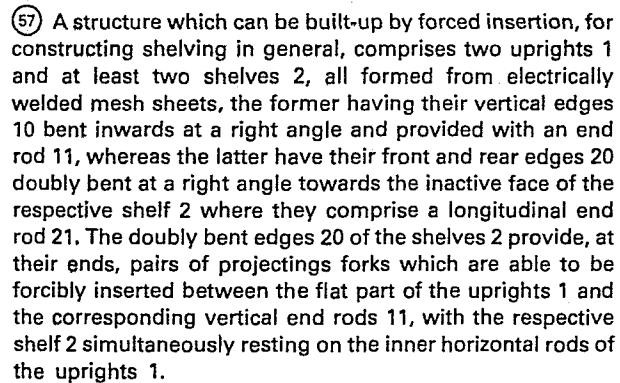

*Fig.2.*

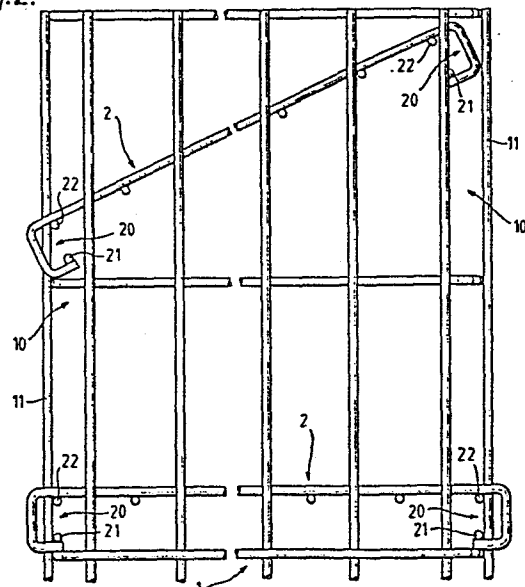

- 1 -

STRUCTURE WHICH CAN BE BUILT-UP BY FORCED INSERTION, FOR  
CONSTRUCTING SHELVING IN GENERAL

5 This invention relates to a flat-element structure which can be  
variously built-up by fitting together its component elements by  
means of forced insertion, which is made possible by the slight  
deformation to which the parts concerned are subjected during their  
fitting.

10 Said elements when assembled provide a sort of shelving which can  
be used in the most diverse ways, for example for housing objects  
or materials, tools, products or others, for example bottles or  
trays.

15 The shelving obtained in this manner can be of fixed type, or alter-  
natively of trolley-mounted type by simply providing it with normal  
castors.

20 Moreover, the shelving of the invention has the merit of being able  
to be assembled without the aid of bolts and their relative spanner  
or tool, and can thus be assembled by anybody, including persons of  
little skill.

25 Furthermore, when dismantled, the structure of the invention is of  
minimum bulk, which makes it extremely simple to package, store  
and transport.

According to the invention, the proposed structure is in the form of a series of electrically welded mesh panels of rectangular shape and of any dimensions, and of which the apertures and the diameters of the component rods depend on the use to which the invention is  
5 to be put.

More particularly, the structure of the invention comprises two panels acting as uprights or shoulders with their vertical edges bent at a right angle, and at least two panels acting as shelves,  
10 the side edges of which are designed to abut against the uprights by lying within the right-angle bent vertical edges of these latter, and to rest on an internal horizontal rod of said uprights.

In addition, the front and rear edges of said panels which act as  
15 shelves are bent double at right angles about themselves in order to provide, at their opposing ends, respective pairs of elastically deformable projecting forks, which can be forcibly inserted between the flat portions of the uprights and the end rods of the right-angle bends of these latter.

20 It is essential, for mounting the shelves, that the distance between the horizontal rods of the shoulders is such as to allow the insertion of the shelves when these latter are in an inclined position, so that before being fitted-in they lie between the bends of said  
25 shoulders.

A structure of this type, even if it comprises only the two shoulders and two shelves, namely an upper and a lower one, is very stable and particularly rigid, even with relatively large mesh apertures and  
30 relatively small rod diameters.

The constructional characteristics and merits of the invention will be more apparent from the detailed description given hereinafter with reference to the figures of the accompanying drawings given  
35 by way of example only, and in which:

Figure 1 is a front perspective view of a structure which can be built-up according to the invention;

Figure 2 is a partial side view to an enlarged scale showing the method of fitting one of the shelf panels;

5 Figure 3 is a plan projection showing a vertical corner of the structure according to the invention to an enlarged scale.

Said figures, and in particular Figure 1, show that the invention comprises two upright or shoulder panels 1, and a series of shelf  
10 panels 2, of which only two are shown in the figure in that only these are essential for the stability and adequacy of the shelving.

As clearly shown, all these panels are constituted by electrically  
15 welded mesh sheets with apertures of convenient dimensions and/or shape, and which can obviously be different from those shown.

The constituent metal rods can also be of any diameter suitable for the purpose, ie for the use to which the invention is to be  
20 put, and in accordance with the loads which it has to support.

Each upright or shoulder 1 comprises a series of vertical rods and a series of horizontal rods, these latter being disposed on that  
face of the panel which faces the structure.

25 The vertical edges of the shoulder 1, or rather the respective horizontal rods, are bent inwards at 10 so that the corresponding panel 1 assumes a channel configuration of small depth.

As clearly shown, the side walls of said channel are practically  
30 open, being intercepted only by the horizontal rods, to form longitudinal openings, the purpose of which will be more apparent hereinafter.

In addition, the free longitudinal edge of each bend 10 comprises  
35 an end rod 11.

The two straight side edges of each shelf panel 2 are designed to abut against the inner faces of the shoulders 1, more precisely against the vertical rods of these latter, whereas its front and rear edges 20 are doubly bent at right angles about themselves, namely downwards and then towards the inactive surface.

Said double bend 20 provides a succession of hooks or types of projecting forks, the two opposing pairs of which each have an overall width which is slightly greater than the distance between the rod 11 and the inner generating lines of the vertical rods of the upright 1 (Figure 3).

In addition, said double bend 20 terminates with a longitudinal end rod 21 which lies directly under the last rod 22 of the flat portion of the shelf 2.

The distance between the outer generating lines of the rods 21, 22 of the front bend 20 and the corresponding outer generating lines of the rear bend 20 is slightly greater than the distance between the generating lines of the respective two rods 11 of the shoulders 1 (Figure 2).

Furthermore, the spacing between the horizontal rods of these latter (Figure 2) is such as to enable a shelf 2 to be disposed in an inclined position as shown in Figure 2 between the two shoulders 1 and between the two corresponding opposing pairs of horizontal rods thereof, after which the two opposing pairs of forks of one of its longitudinal edges is forcibly inserted into the corresponding apertures defined by the rods 11, following which it is forced downwards so that it engages with the remaining two rods 11.

On termination of this operation, the panel 2 is supported by the corresponding horizontal rods of the shoulders 1.

The procedure is repeated for all the other required shelves, whereas the reverse procedure is carried out for dismantling.

- 5 -

The structure heretofore described has all the characteristics stated in the initial part of the present description, and can be used in the most varied ways as heretofore stated.

- 5 If required, the invention can be trolley-mounted, for example by using normal castors, so that it can be used as a tool carrier, equipment carrier or as a mobile bar.

10 In this latter case it is necessary only to upperly provide a panel 2 having mesh apertures suitable for receiving bottles, and to lowerly provide a panel 2 with narrower mesh apertures.

15 This structure is also suitable for supporting trays, in which case shelves 2 are provided comprising only an outer rim, on which the perimetral projecting edges of said trays are rested.

Finally, it is apparent that the structure of the invention can be associated with any number of similar structures.

## PATENT CLAIMS

1. A structure which can be built-up by forced insertion for forming shelving in general, characterised by comprising two equal panels acting as uprights or shoulders 1, and at least two equal panels acting as shelves 2, all formed from layers of electrically welded mesh, the former being provided with two opposing vertical right-angled bends 10 pointing inwards where they comprise a vertical end rod 11 and to which the horizontal rods also extend, whereas the latter have their front and rear edges 20 doubly bent at right angles about themselves towards the inactive surface of the panel 2 where they comprise a longitudinal end rod 21 to thus form, on each of their terminal portions, at least two adjacent projecting forks able to be forcibly inserted between the inner face of the shoulder 1 and the respective vertical end rod 11, the panel 2 simultaneously resting on two inner opposing horizontal rods of said two shoulders 1.
2. A structure as claimed in claim 1, characterised in that the overall distance between the longitudinal end rods 21 provided along the double bends 20 of the shelves 2 is slightly greater than the distance which separates the facing generating lines of the vertical end rods 11 of the shoulders 1.
3. A structure as claimed in claim 1, characterised in that the overall outer dimension of said at least two adjacent forks provided at the ends of said two bends 20 is slightly greater than the distance between the facing generating lines of the vertical end rod 11 and of the vertical rods pertaining to the flat portion of the shoulders 1.
4. A structure as claimed in claim 1, characterised in that the distance between the inner horizontal rods of the shoulders 1 is at least slightly greater than the vertical dimension of the panels 2, so that these latter can be inclined in the direction of the depth between the two shoulders when being fitted or removed.

Fig. 1.

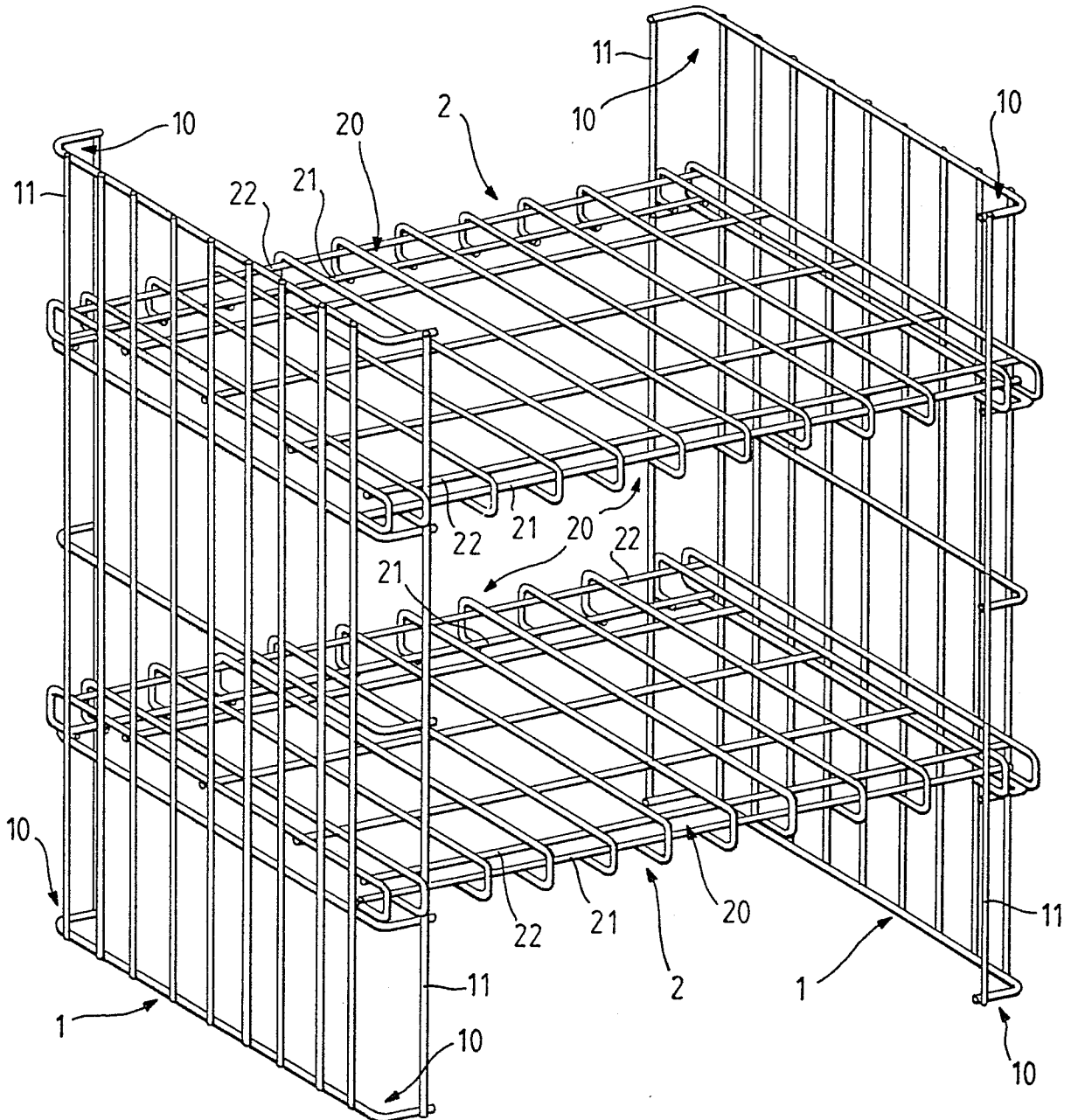

Fig. 2.

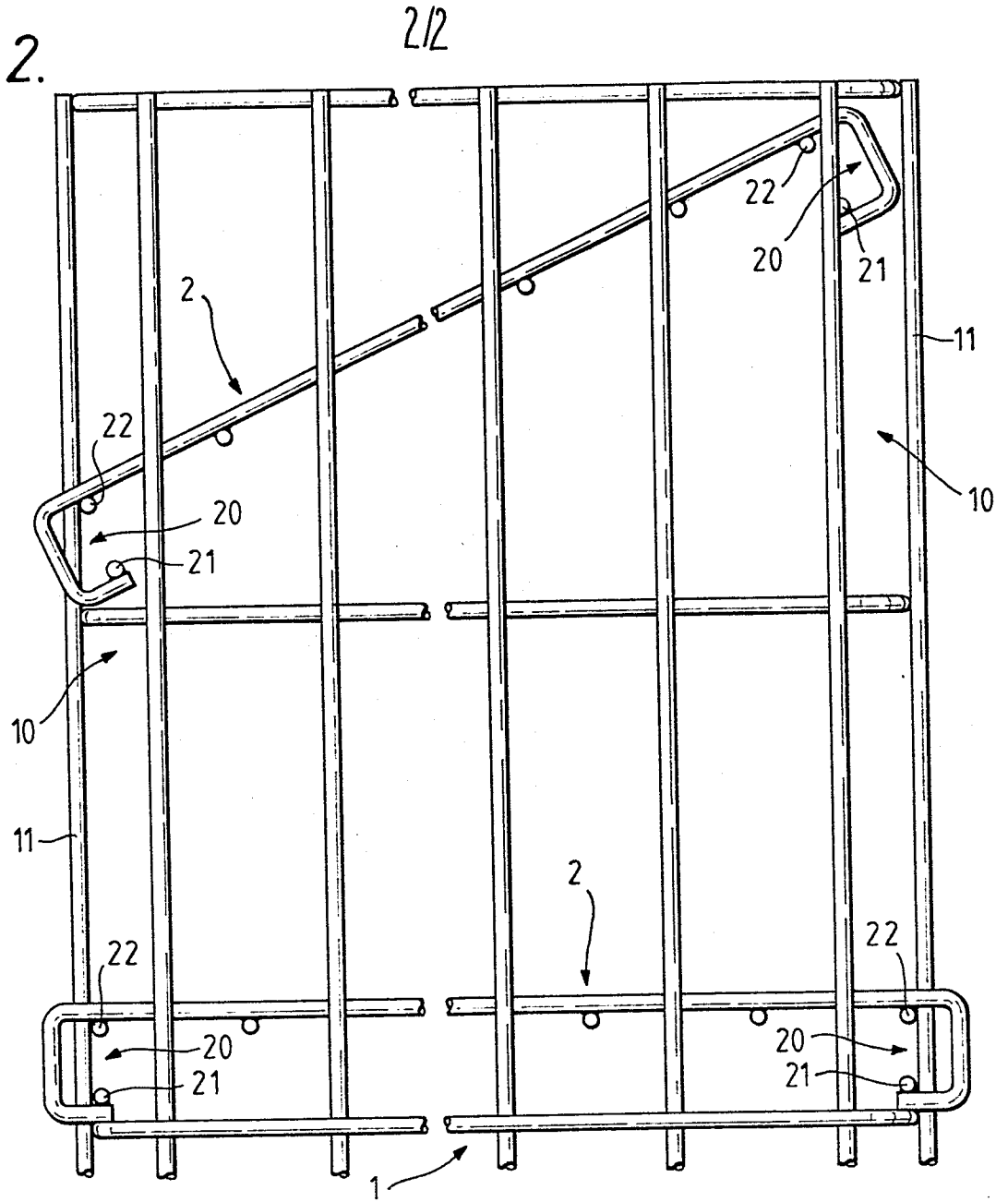

Fig. 3.

