

C. J. WADSWORTH.
 DISPLAY RACK.
 APPLICATION FILED SEPT. 15, 1910.

Patented July 18, 1911.

4 SHEETS—SHEET 1.

998,056.

Fig. 1.

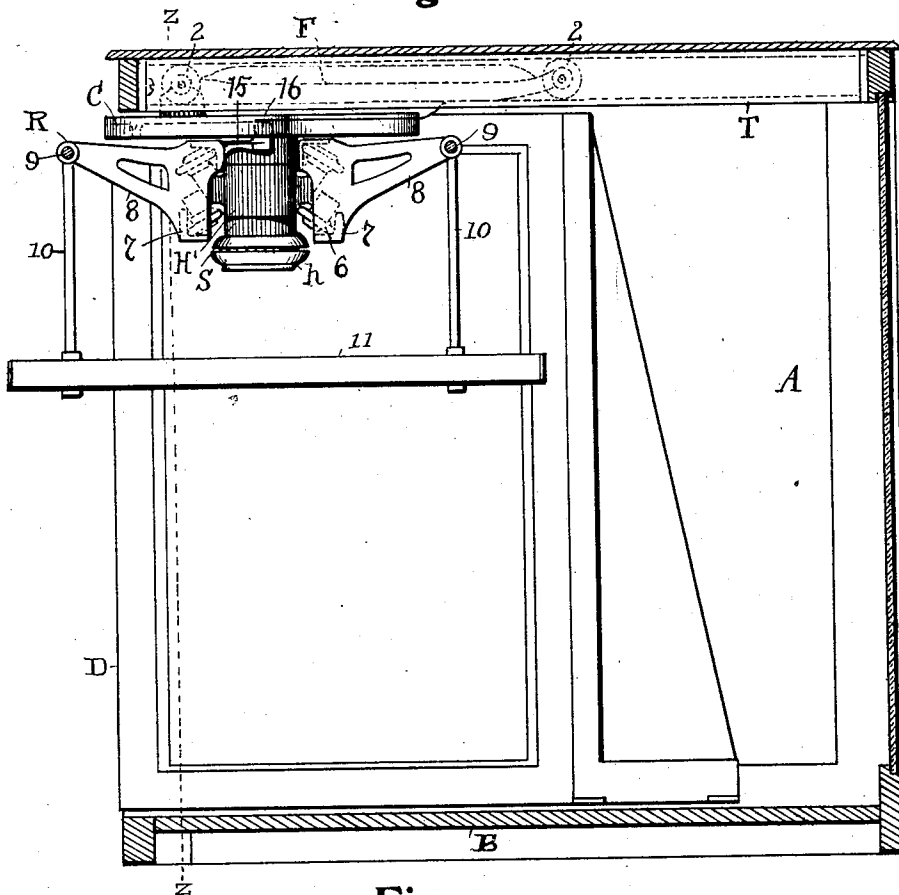
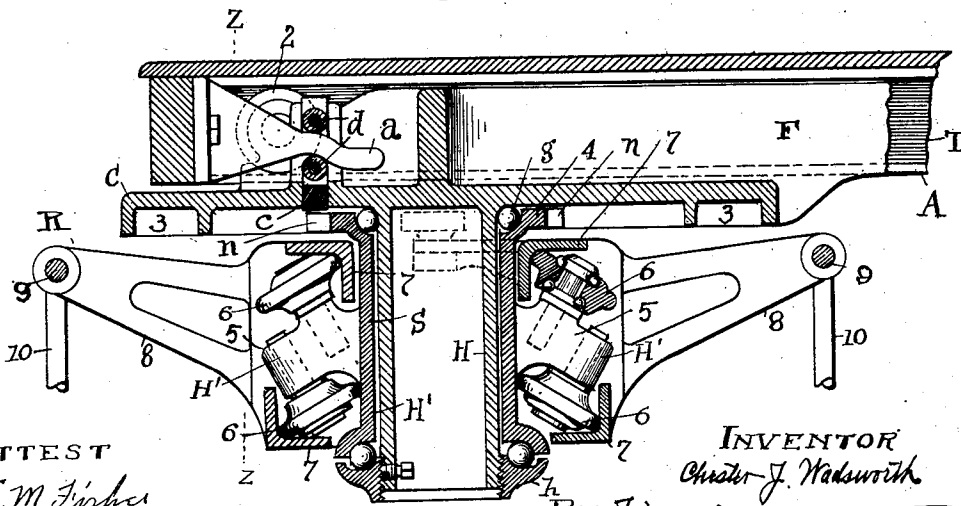

Fig. 2.



ATTEST
E. M. Fisher
J. C. Mearns

INVENTOR
Charles J. Wadsworth
 BY *Fisher & Mearns* ATTYS.

C. J. WADSWORTH.
 DISPLAY RACK.
 APPLICATION FILED SEPT. 15, 1910.

998,056.

Patented July 18, 1911.

4 SHEETS—SHEET 2.

Fig. 3.

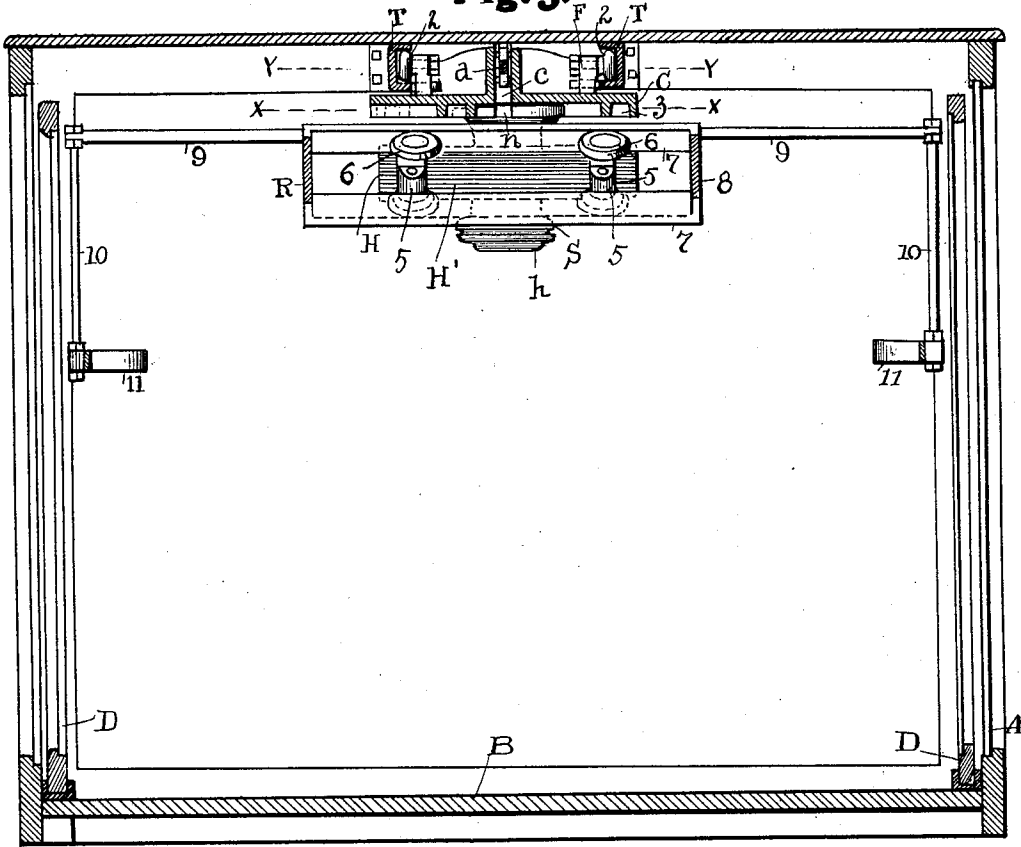
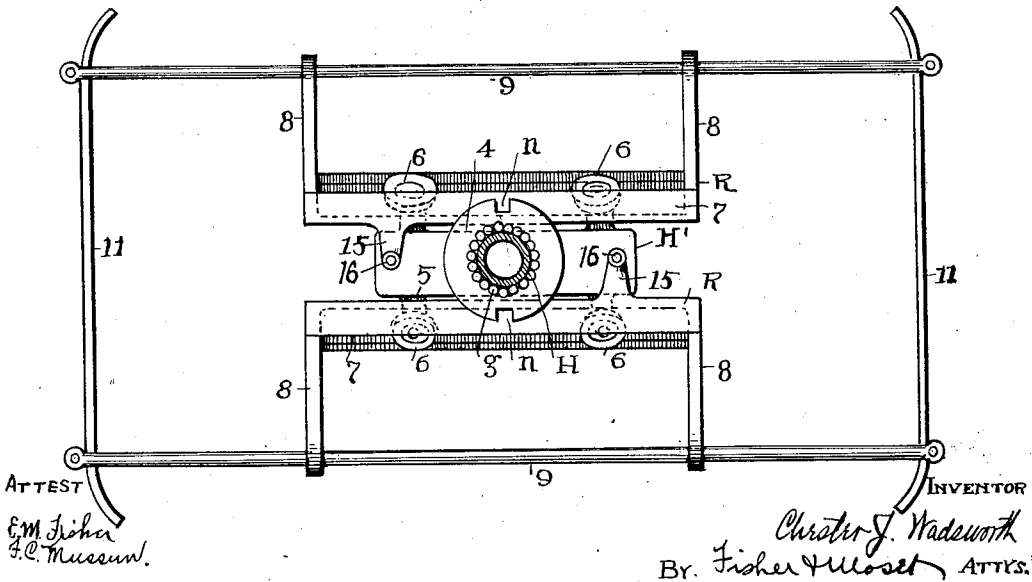

Fig. 4.



ATTEST
 E. M. Fisher
 F. C. Musson.

INVENTOR
 Charles J. Wadsworth
 By: Fisher & Musson, ATTS.

G. J. WADSWORTH.
DISPLAY RACK.
APPLICATION FILED SEPT. 15, 1910.

998,056.

Patented July 18, 1911.

4 SHEETS-SHEET 3.

Fig. 5.

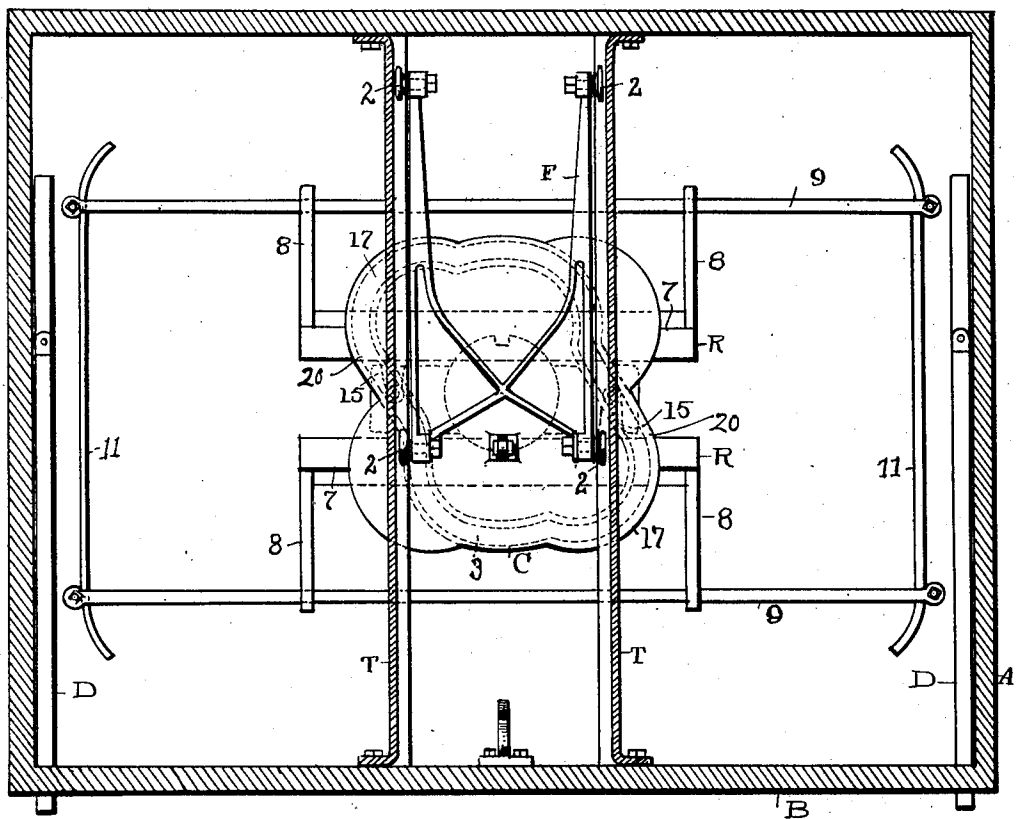

ATTEST
E. M. Fisher,
J. C. Muesel.

INVENTOR.
Chester J. Wadsworth
BY Fisher & Muesel
ATTYS.

C. J. WADSWORTH.
 DISPLAY RACK.
 APPLICATION FILED SEPT. 15, 1910.

998,056.

Patented July 18, 1911.

4 SHEETS—SHEET 4.

Fig. 6.

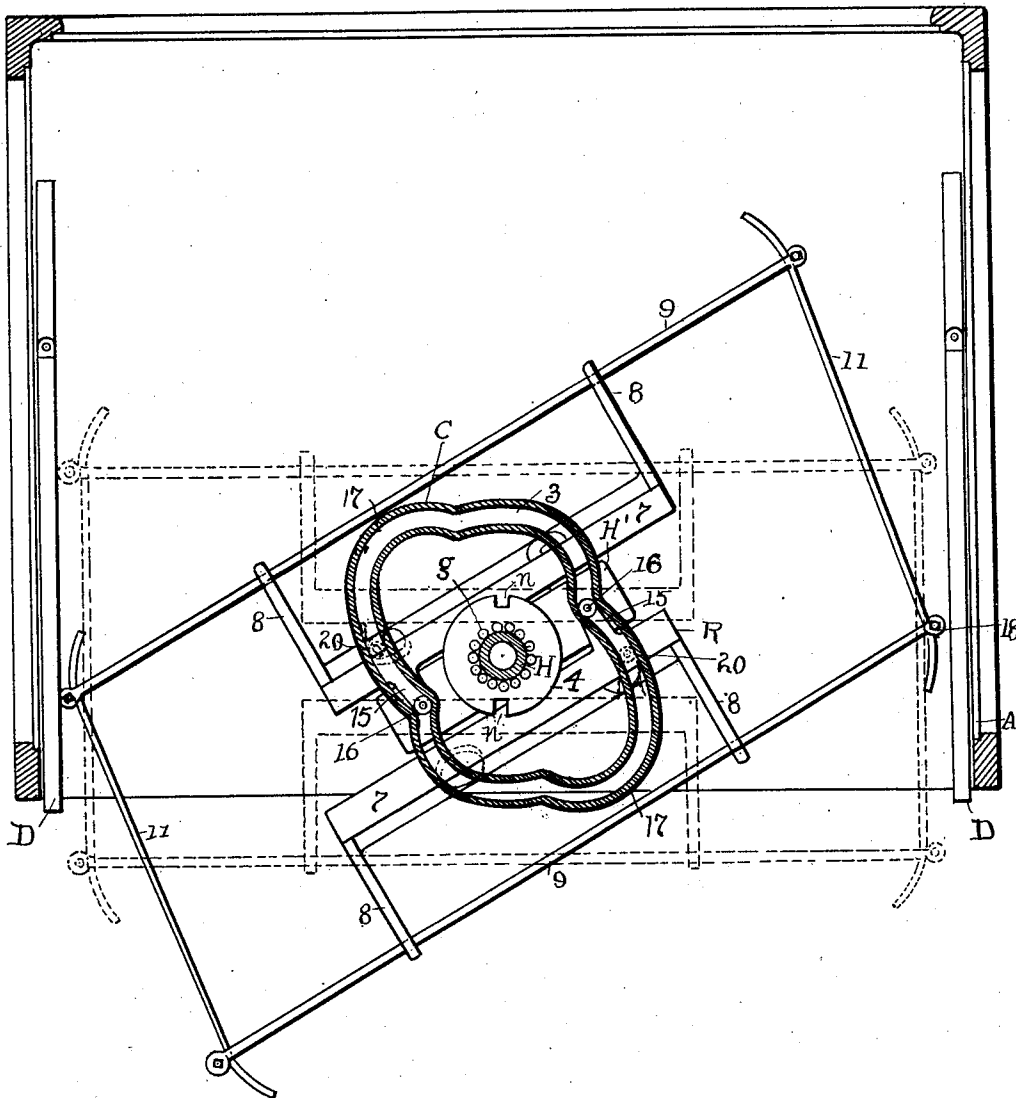

ATTEST
E. M. Fisher.
J. C. Musson.

INVENTOR
Christor J. Wadsworth
 BY *Fisher & Mosset* ATTYS.

UNITED STATES PATENT OFFICE.

CHESTER J. WADSWORTH, OF CLEVELAND, OHIO.

DISPLAY-RACK.

998,056.

Specification of Letters Patent.

Patented July 18, 1911.

Application filed September 15, 1910. Serial No. 582,138.

To all whom it may concern:

Be it known that I, CHESTER J. WADSWORTH, citizen of the United States, residing at Cleveland, in the county of Cuyahoga and State of Ohio, have invented certain new and useful Improvements in Display-Cabinets, of which the following is a specification.

My invention relates to display cabinets adapted to be used in gents' furnishing and other retail establishments for the display and protection of ready-made garments, all substantially as shown and described and particularly pointed out in the claims.

In the accompanying drawings, Figure 1 is a vertical cross section of the cabinet front to rear and a side elevation of the operating parts therein shown as drawn to the front of the cabinet, and Fig. 2 is an enlarged vertical sectional elevation of certain of said operating parts as hereinafter more fully described. Fig. 3 is a vertical sectional elevation of the cabinet lengthwise and corresponding substantially to line $z-z$, Figs. 1 and 2. Fig. 4 is a plan view of the so-called rack, taken on a line not shown but which would come just below $x-x$, Fig. 3 and the cam shown in said figure. Fig. 5 is a plan view on line $y-y$, Fig. 3 showing especially the track for the rack transversely of the cabinet and the rack beneath, and Fig. 6 is a plan on line $x-x$, Fig. 3 but with the rack shifted to an angle for rotation as compared with said figure.

The modern or up-to-date ready-made clothing establishment has for the most part abandoned the old practice of stacking clothing on shelves or tables or in drawers, especially as to its finer or better goods, and demands display cabinets or showcases in which the clothing can not only be suspended on racks or rods with a separate hanger for each article but which will enable the article to be shown as it hangs in place and wherein all the garments in a given cabinet may be easily drawn out and inspected and at the same time are protected from dust and injury. This demand for advantageous display along with protection of the goods however involves the consideration of economy in space, and a few feet of area saved in a given cabinet with equal room for clothing is exceedingly important where room is at a premium and a large number of cabinets have to be used.

My invention, therefore, has as one of its important objects and accomplishments the economizing of space in cabinets having otherwise the popular or accepted capacity, and the invention involves these considerations along with an angular shape of jointed sectional slidable rack and means to rotate the same in a cabinet or case wherein the length of the rack is approximately equal to the entire interior length of the case, as will hereinafter fully appear.

Now, having reference to the means employed for this purpose, A represents a rectangular cabinet or case of greater length than depth in this instance and preferably made with glass sides and of artistic design and finish and provided with doors D adapted when open to slide into the ends thereof but otherwise closing the front of the cabinet, and a floor B in its bottom. The carrying and operating mechanism comprising the rack R is bodily supported within the top of the cabinet on channel iron tracks or rails T front to rear across the middle thereof and in this instance fixed to the top of the cabinet, and a rigid spider shaped frame F has rollers 2 running on said track.

C represents a cam or cam member or plate integral with the bottom of frame F as shown herein but which may be a separate part fixed on the bottom of said frame and which has an endless flanged cam channel 3 on its under side of approximately 8 shape and diagonally disposed as to the corners of the cabinet.

A tubular hub or extension H depends centrally from cam C, and the clothes carrier frame or rack R is supported from about this hub by means of a rectangular head H' having a sleeve S at its center rotatably mounted on said hub. Specifically, the said hub H has a collar h screwed upon its bottom and provided with a ball race on its top supporting said sleeve S, and another ball race with balls g is provided at the top of said sleeve about said hub, so that the sleeve will turn easily and noiselessly thereon. Said sleeve also has a horizontal flange 4 about its top next beneath cam C and said head H' is further provided with opposite brackets or bearings 5 on its sides and ends extending laterally and upon opposite sides of which, above and below, rollers 6 are mounted and adapted to support said rack.

The said brackets are set at an inclination downward and the rollers 6 are mounted on an inclined axis with their working edges in the same vertical plane relatively near to
 5 said sleeve. Four rollers 6 are used on each side of head H' and in parallel lines above and below. The said rack comprises sundry parts or portions including two parallel
 10 angle iron rails 7 at each side above and below and inside and outside respectively of the said rollers 6, Fig. 2, and running thereon, so that the said rack as an entirety rests on these double sets of rollers and is adapted to travel thereon within the limits of its
 15 movements in and through cam C as also will presently be seen. Oppositely disposed arms 8 are integral with said pairs of rails and connect said rails 7 at their base and bars or rods 9 are carried by said arms, while
 20 hangers 10 depend from the ends of said rods 9 and carry the clothes guards 11. The said pairs of rails 7 are operatively independent of each other within limits and their only working connection or relation
 25 is through the framework of the rack just described, and by reason of their common support from or upon opposite sides of H' on rollers 6.

From the foregoing it is evident that the
 30 rack as a whole is adapted to move within limits on rollers 6 and also has a rotatable movement with sleeve about hub H, and both these movements are incident to the shifting positions of the rack as determined by cam
 35 C and necessary thereto in order that space may be economized and the largest display room possible be obtained therein as hereinafter mentioned.

The retired position of the rack is shown
 40 in Fig. 5, and the front or display position is about as seen in dotted lines Fig. 6, wherein the rack is rotatable in respect to the cabinet and either end may be turned to the front. In this position the display frame
 45 or frame sections or members are adapted not only to be rotated by hand but to automatically shift lengthwise more or less in respect to each other and at the right times to afford clearance at their corners where
 50 contact with the sides of the cabinet would occur and prevent rotation if the frame were rigid or such shifting of position were not provided for. In fact if no such accommodation were made and the frame was
 55 rigid, it could not possibly be rotated out of the cabinet with any such length as it now contains but by my novel construction and arrangement of parts with tracks and cam as shown I can use a rack which is
 60 substantially the full length of the cabinet and yet turn it in and out and rotate it with plenty of clearance at the angles and with the utmost ease in operation. Furthermore all accommodations are automatic and cer-
 65 tain. Now, in these operations, I employ

the cam plate C with its original and novel shape of endless cam groove 3 in its bottom as shown and described and in which each rack member or section is directly engaged
 70 by an arm 15 therefrom having a roller 16 on its top running in said groove or channel. The relation of said cam lengthwise is practically diagonal as to the front of the cabinet and it is fixed as to position, so that its
 75 ends 17, wherein the cam channel is farthest from the center, lie toward diagonal corners of the cabinet front and rear, while the narrower middle portion of the said channel is at the middle of said cam opposite the center
 80 thereof and said narrowed portion is diagonal as to the other corners of the cabinet. The full lines in Fig. 6 show the rack frame as a whole with its rollers 16 in this narrow portion or relation, thus drawing
 85 said frame sections inward as to the center and shifting them at their opposite corners diagonally for clearance. Next to this narrow portion of the cam at each side it has a rather abrupt swell or turn 20 outward,
 90 which shifts the said frame members again in opposite directions the extreme of their movement in a short space or distance of travel as one end or the other is projected without the cabinet. Thus it is possible to
 95 rotate either side or end of the rack to the front and pay no attention to the working thereof as this automatically takes care of itself, and when through with showing the goods the entire stand need simply be pushed
 100 back in the cabinet and it will automatically resume its place.

The guards 11 suspended from the end of the display racks protect the skirting of the garments at the sides of the casing but the garments are suspended from the rods 9.
 105

The rack R is adapted to be locked as a whole or unit when in either advanced or retired position by means of devices shown in
 110 Figs. 2 and 3. These devices comprise a drop catch *c* confined within posts or the like on top of cam C and having rollers *d* therein spaced apart and adapted to be entered between by an arm *a* fixed in the end of the cabinet frame immediately under the
 115 top, Fig. 5. Said arm has a point or end with undulating or uneven edges adapted and arranged to lift said catch in one position of the rack and to depress it to locking position in another position of the rack,
 120 when it engages in a notch *n* in flange 4, Fig. 4. This occurs as the rack is retired.

In operation the entire rack is first drawn out on rails T and this brings cam C and all the associated parts out together. Then
 125 the rack is brought at once under the domination of cam C as to position for rotation and shifting oppositely endwise to clear the cabinet. After the rack is unlocked and rotated, frame F is locked against inward
 130 movement by flange 4 and arm *a*, said flange

preventing downward movement and the downwardly inclined end of the arm preventing lateral travel of catch *c*.

What I claim is:

5 1. A garment display cabinet and means therein to carry the garments adapted to be drawn out and rotated, the same comprising a rack slidable transversely in said cabinet and a cam in the top of the cabinet, said rack having bars slidable in parallel lines in respect to each other and a roller engagement between each of said bars and said cam.

15 2. A garment display cabinet having tracks transversely therein, a rack for the garments mounted on said tracks and having separate side sections and a cam with which said sections are separately engaged, said sections having jointed connections and rotatable together in respect to said cam.

20 3. The combination described comprising a cabinet and a garment supporting rack slidable back and forth in straight lines therein, said rack having two separately movable side parts, a support on which said rack is rotatable and means adapted to automatically slide said parts of the rack when it is rotated and thereby enable the said rack to turn in the cabinet.

30 4. The cabinet and the display mechanism comprising a straight track therein, a display rack mounted on said track and consisting of two side parts, a cam having said parts operatively engaged therewith and means to rotate said rack in respect to said cam.

35 5. A garment display cabinet and a sectional display frame therein, a head having said sections slidably mounted on opposite sides thereof and a cam and connections with said sections working therein and adapted to slide said sections independently.

40 6. A rectangular garment display cabinet and a display frame in two parts having the ends thereof next to the ends of said cabinet, a support on which said frame is rotatable and means to cause the parts of said frame to slide independently when rotation of the frame occurs.

50 7. A garment display cabinet and a display support transversely movable therein, in combination with a sectional display frame rotatably mounted in respect to said support, a cam in the top of said cabinet and means operatively engaging said display sections therewith and adapted to slide said sections simultaneously in opposite directions.

60 8. A garment display cabinet having tracks in its top, a frame slidable in said tracks and a cam mounted on the bottom of said frame, a head rotatably mounted be-

neath said cam and a rack slidable on said head and connections therefrom with said cam.

9. A cabinet and a garment display rack therein, a support on which said rack is movable back and forth in the cabinet, a cam movable with said rack and operating means engaging said rack with said cam.

10. The cabinet and the transverse tracks therein, a display rack, and means suspending said rack from said tracks comprising a traveling frame, a head rotatably mounted in respect to said frame and said rack having slidably engagement with said head.

11. A cabinet and a display frame therein comprising independent sections loosely connected at their ends and a rotatable member having said frame slidably mounted thereon and adapted to rotate therewith and a cam operatively engaged by said frame and adapted to govern the rotations thereof.

12. A garment display cabinet and a sectional display frame therein, a support in said cabinet on which said frame is adapted to travel back and forth and means engaged with said support on which said frame is both slidably and rotatably mounted.

13. The combination of the cabinet and the tracks therein, a frame adapted to travel on said tracks having a cam at its bottom and a hub depending therefrom, a head rotatably mounted on said hub and a clothes rack slidably mounted on said head and operatively engaged with said cam.

14. A garment display rack having a track in its top, a carrier mounted on said track, a clothes supporting frame, means suspending the same from said track adapted to be rotated and a cam by which such rotation is governed.

15. A rectangular cabinet and a rectangular clothes carrying frame therein having loosely jointed corners, a cam and means operatively connecting opposite sides of said frame therewith.

16. A rectangular cabinet and a rectangular clothes supporting frame therein consisting of two sections longitudinally movable in respect to each other and connected at their ends, in combination with means supporting said frame adapted to rotate said frame thereon and a cam having said frame sections separately engaged therewith and constructed to give said sections similar movements in opposite directions as said frame is rotated.

In testimony whereof I affix my signature in the presence of two witnesses.

CHESTER J. WADSWORTH.

Witnesses:

R. B. MOSER,
F. C. MUSSUN.