



- (51) International Patent Classification:
H05B 37/02 (2006.01)
- (21) International Application Number:
PCT/EP2010/058151
- (22) International Filing Date:
10 June 2010 (10.06.2010)
- (25) Filing Language: English
- (26) Publication Language: English
- (30) Priority Data:
09162462.7 10 June 2009 (10.06.2009) EP
09164468.2 2 July 2009 (02.07.2009) EP
61/234,548 17 August 2009 (17.08.2009) US
- (71) Applicant (for all designated States except US): **ILEDs GMBH** [DE/DE]; Geschwister-Scholl-Allee 82, 14532 Kleinmachnow (DE).
- (72) Inventors; and
- (75) Inventors/Applicants (for US only): **MOKHTARI, Ramin, Lavae** [DE/DE]; Geschwister-Scholl-Allee 82, 14532 Kleinmachnow (DE). **LANG, Ortwin** [DE/DE]; Ziegeleistr. 2, 30880 Laatzen (DE).
- (74) Agent: **KINKELDEY, Daniela**; Bird & Bird LLP, Pacellistraße 14, 80333 München (DE).

- (81) Designated States (unless otherwise indicated, for every kind of national protection available): AE, AG, AL, AM, AO, AT, AU, AZ, BA, BB, BG, BH, BR, BW, BY, BZ, CA, CH, CL, CN, CO, CR, CU, CZ, DE, DK, DM, DO, DZ, EC, EE, EG, ES, FI, GB, GD, GE, GH, GM, GT, HN, HR, HU, ID, IL, IN, IS, JP, KE, KG, KM, KN, KP, KR, KZ, LA, LC, LK, LR, LS, LT, LU, LY, MA, MD, ME, MG, MK, MN, MW, MX, MY, MZ, NA, NG, NI, NO, NZ, OM, PE, PG, PH, PL, PT, RO, RS, RU, SC, SD, SE, SG, SK, SL, SM, ST, SV, SY, TH, TJ, TM, TN, TR, TT, TZ, UA, UG, US, UZ, VC, VN, ZA, ZM, ZW.
- (84) Designated States (unless otherwise indicated, for every kind of regional protection available): ARIPO (BW, GH, GM, KE, LR, LS, MW, MZ, NA, SD, SL, SZ, TZ, UG, ZM, ZW), Eurasian (AM, AZ, BY, KG, KZ, MD, RU, TJ, TM), European (AL, AT, BE, BG, CH, CY, CZ, DE, DK, EE, ES, FI, FR, GB, GR, HR, HU, IE, IS, IT, LT, LU, LV, MC, MK, MT, NL, NO, PL, PT, RO, SE, SI, SK, SM, TR), OAPI (BF, BJ, CF, CG, CI, CM, GA, GN, GQ, GW, ML, MR, NE, SN, TD, TG).

Published:

— without international search report and to be republished upon receipt of that report (Rule 48.2(g))

(54) Title: LIGHTING UNIT, NETWORK OF LIGHTING UNITS AND METHOD FOR CONTROLLING THE LIGHT INTENSITY OF A LIGHTING NETWORK COMPRISING AT LEAST ONE LIGHTING UNIT

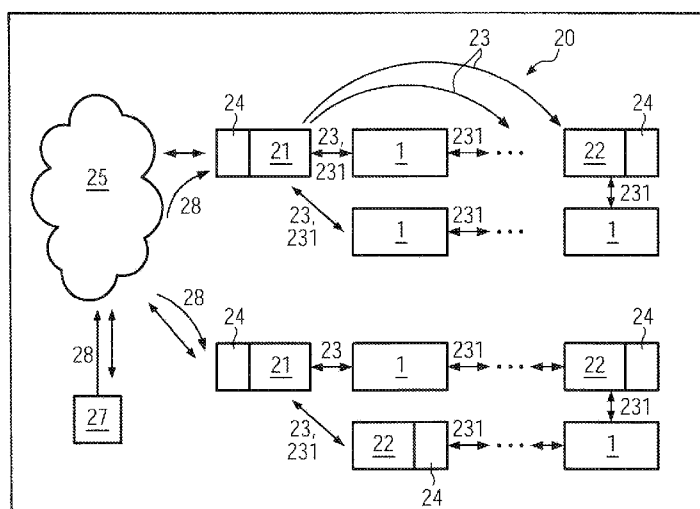

FIG. 2

(57) Abstract: The invention relates to a lighting unit comprising at least one LED, a processing unit for controlling the light intensity of the at least one LED, an ambient sensor for measuring at least one ambient parameter within a predetermined range of the lighting unit, a data storage unit containing at least one light intensity value For a predetermined period of time connected with a time value, a time registration device for providing a time value, wherein the processing unit is adapted such that one of the at least one light intensity values is chosen depending on the provided time value and the light intensity is controlled on basis of the chosen light intensity value and the at least one measured ambient parameter.

WO 2010/142764 A2

Lighting unit, network of lighting units and method for controlling the light intensity of a lighting network comprising at least one lighting unit

The present invention relates to a lighting unit, network of lighting units and method for controlling the light intensity of a lighting network comprising at least one lighting unit.

5 For providing an illumination on streets, railway stations, harbours, parking places or other exterior scenarios currently different systems are discussed. In regard to effectiveness one aspect is the use of LEDs (light emitting diode), which ensures a reduction of power consumption and maintenance costs in respect to usual lighting means by increasing the comfort, life time and functionality. A further aspect is an effective control of local
10 networks of individual lighting elements, e.g. of lanterns, street lamps or lamps in a railway or metro station.

It is one object of the invention to provide a possibility for an effective illumination particularly for exterior scenarios which is cost and energy efficient.

This object is solved by what is disclosed in the independent claims. Advantageous
15 embodiments are described by the dependent claims.

Preferred embodiments are:

A lighting unit comprises a lighting element with at least one LED. The light intensity of the at least one LED is controlled by a processing unit. Further, an ambient parameter is measured by an ambient sensor and is detected within a predetermined range of the
20 lighting unit. This predetermined range may be defined by the light cone of the lighting element or a range of the ambient sensor.

The lighting element may comprise only one LED or a group of LEDs. The number and also the type of used LED may vary depending on the purpose, e.g. the desired brightness, the number of existing lanterns, the height of a street lantern and the area to be illuminated.

25 The lighting unit further comprises a data storage unit wherein at least one light intensity value is stored for a predetermined time interval. E.g. a first light intensity value is provided for the time interval between 8 o'clock in the evening and midnight, where a maximum of illumination might be needed. At twilight times between 5 and 8 o'clock in

the evening, as well as in corresponding morning hours, different illumination values are provided, according to which the brightness is dimmed in relation to the maximum value. For the daylight time between 8 o'clock in the morning and 5 o'clock in the evening a light intensity value may correspond to 0% of the maximum value as no illumination is needed.

- 5 In particular, for defining the illumination values, apart from the time interval also the season may be taken into account.

Preferably the light intensity values can be adapted according to the actual requirements such as winter, summer, position, weather or other factors that influence the required illumination for a predetermined time interval. In the case of a lighting network this may
10 be done by providing external control data to the lighting unit. Thus, the lightning network allows various settings and conditions but may additionally include one pre-defined condition based on customer needs which may be applied every time the light is being switched on by the grid. This ensures the usage of the lightning network in the same way as any other existing system in the past.

- 15 A corresponding time interval is chosen by use of a time registration device, by which a time value is provided. The time value, e.g. 9 o'clock in the evening, lies within the time interval between 8 o'clock in the evening and midnight, which is chosen accordingly and thus the light intensity value for this time interval is chosen.

The time registration device may measure the time value itself or receive a time value.
20 Particularly, the time registration device may be contained in the processing unit.

The processing unit is adapted such that one light intensity value is chosen dependent on the provided time value and further the light intensity is controlled on the basis of the chosen light intensity value and a measured ambient parameter. The ambient parameter may be e.g. the surrounding light intensity, particularly in order to control the illumination
25 for cloudy or sunny days, a movement measurement in order to detect whether there are any activities in the area of the lighting unit so that it can be determined whether an illumination is required. Further, the ambient parameter may be a destruction or removal of at least one part of the lighting unit in order to detect any theft or act of vandalism at the lighting unit. Further, the ambient parameter can comprise a measurement of the quality of
30 the LED, e.g. the required brightness for a given driving current at a predetermined distance from the LED.

The existence of an ambient sensor in a lighting unit provides -- if a network of lighting units is considered -- ambient data relating to the positions, which are to be illuminated. Thus, without further separate measurement units the ambient data can be gathered exactly at the position where they are needed for an adequate illumination.

5 Apart from other advantages such as lifetime, robustness and low power consumption the use of LEDs for illuminating an exterior is that the emitted light is scattered significantly less than with usual light sources. Thus, the light pollution can be reduced. Further, the LEDs can be chosen such that a low colour temperature is achieved. Thus, insects are less attracted by the lighting units and therefore not destroyed. Further, the lighting units are
10 soiled less with the remains of insects.

Each lighting unit may furthermore be equipped with different reflectors and/or lids. Each lighting unit is suitable for a broad range of light situations and heights. The LED lighting power can be adjusted for various required brightness. The provision of a reflector allows for adjusting the light from each LED to be assembled into a desired light cone for a
15 desired distance of the lanterns or to minimize the number of lanterns and lighting systems required and optimizing the costs. Additionally, customers can purchase different lids to adjust the colour, design or optical size of the lighting unit. Once the lighting units are installed, the lights will be adjusted for the existing ground situations by easily adjusting the LED brightness from a wireless point. In particular, data provided by the ambient
20 sensor or/and a further sensor positioned at the lighting unit, in particular in a reflection unit or in the processing unit, or a component of any of these sensors may be used for adjusting the LED brightness.

In particular, if the lighting unit is placed on a pole, the LED brightness or intensity may be adjusted to various pole heights and pole distances easily. This allows the use of one
25 lighting unit for different applications and thus reduces costs during production.

According to another embodiment the lighting unit further comprises a wireless transmission unit for receiving and/or additionally sending data. Thus, external control information can be received by the lighting unit to respond e.g. to centrally given instructions. Further, data can be sent from a lighting unit to a central unit or another
30 lighting unit in regard to measured ambient parameters, such as movement, failures etc. at the lighting unit.

According to a further embodiment the transmission unit is adapted for wireless transmission. Thus the lighting unit can be used flexibly, as no wired infrastructure is required.

5 According to a further embodiment, the wireless transmission unit is adapted for short range transmission, i.e. a transmission to another lighting unit, particularly a neighbored lighting unit. Thus, a communication between lighting units can be established, e.g. for the exchange of ambient parameters.

10 According to another advantageous embodiment the wireless transmission unit is adapted for short range transmission as well as for long range transmission. By the short range transmission, e.g. up to a few hundred meters, the communication between individual lighting units can be ensured. By the long range transmission, e.g. realised by mobile communications standards, such as GSM or UMTS, a communication with a central control unit can be ensured. The central control unit may be accessed directly by this long range communication standard or via at least one further network, e.g. an internet network.

15 According to a further embodiment, the transmission unit is adapted - alternatively or additionally - for transmission via a wired connection. Thus particularly an already existing connection, such as the power line connection can be used for transmission of signals, particularly control signals, from and to the lighting unit.

20 In the case that the transmission unit is adapted for both, wireless and wired transmission, wired networks can be used where existing in order to reduce radiation or enhance the transmission. On the other hand a high flexibility is ensured by the wireless transmission unit, so that structures of lighting units that do not follow the predetermined structures of existing wired networks can be used.

25 According to another embodiment the control is set up on basis of or by using at least one ambient parameter for an open loop or a closed loop control of the light intensity of the lighting element or each individual LED. Thus, it can be responded quickly to a required brightness. Alternatively or additionally an accurate control taking into regard the brightness due to the actually emitted light can be provided.

30 According to another embodiment an internal control signal may be provided by the processing unit to an electrical circuit for controlling the light intensity of the lighting

element or the LED. This internal control signal is bit angle modulated to provide an effective and easy control. Particularly in response to the internal control signal the electrical circuit may provide the driving current to each LED separately or to a group of LEDs or to the lighting element as a whole. Alternatively, a driving voltage may be provided.

Particularly AC or DC current may be provided to an individual LED, a group of LEDs or the lighting unit. An electrical circuit of the lighting unit may be arranged such that either AC or DC power can be received. Alternatively, an AC/DC switch may be provided for selecting either AC or DC power. According to an advantageous embodiment the lighting unit may comprise a power conversion unit for providing solar or wind energy to the lighting unit. Particularly, further energy storing units, such as batteries, are provided in order to compensate for times when e.g. there is no wind or sun. Thus, the lighting unit needs not to be connected to a power network.

According to a further embodiment a lighting network is formed which comprises at least two lighting units which communicate with each other by use of their transmission units. One of the two lighting units acts as a master lighting unit which provides external control data to at least one other lighting unit which acts as a slave lighting unit.

Particularly the transmission unit is formed by a wireless transmission unit. The master lighting unit may create the external control data by itself or receive them via its wireless transmission unit, which is particularly also adapted for a long range transmission, such as a wireless telecommunication transmission.

Alternatively or additionally the transmission unit is adapted for transmission via a wired connection, which allows an effective transmission in fixed structures.

Such a lighting network has the advantage of an effective overall control because only the master lighting unit has to be addressed in order to change the light intensity for any lighting unit in the network. Thus, the number of long range transmission is reduced and also only a master lighting unit needs a wireless transmission unit adapted for long range transmission. Thus, the production costs for slave lighting units can be reduced.

Alternatively or additionally in the case of a wired transmission only the master lighting unit can be connected to a long range network, in order to avoid to many participants and therefore a high traffic in the long range network.

5 Further, e.g. in comparison to a network for which each individual lighting unit which is not equipped for performing a long range transmission, is controlled via communication to a central control unit, the size of the network can be increased, because a slave lighting unit needs only to communicate to a neighbored lighting unit or a lighting unit being within the range of its wireless transmission unit.

10 Alternatively or additionally in the case of a wired connection a simple structure of the fixed network suffices to allow for an effective communication.

Further, as a local control for a predetermined area is hidden in a master lighting unit, it is more difficult to destroy a lighting network than if, e.g. the local control was positioned in a highly visible or at least better visible position.

15 According to an advantageous embodiment an anti-theft system is included. Particularly the anti-theft system works such that a lighting unit works only in its lighting network. Further, in case of a theft, a theft message may be sent to a neighbored lighting unit.

According to another advantageous embodiment the master lighting unit in a lighting network receives one or more ambient parameters from one or more slave lighting units. The master lighting unit uses this or these ambient parameter(s) in order to create external control data. These external control data are then sent to one or more specified slave lighting unit(s). Thus, the ambient data for the relevant areas to be illuminated are available for the lighting network and not e.g. data from sensors at positions not relevant for the lighting network. Further, no additional sensor data have to be used and thus the lighting network can be operated independently from other networks.

25 Alternatively or additionally, the ambient parameters may be sent from the master lighting unit to a central control unit, which uses it for creating the overall control information or protocols. According to another embodiment external control data are created by using overall control information from a central control unit, e.g. a web server or a local control master, e.g. a laptop, PC, PDA, etc.

The overall control information may particularly refer to individual lighting units or to a group of slave lighting units depending on the master lighting unit to which the control information was sent.

According to another embodiment information is transferred from a lighting unit to a neighboured lighting unit. Thus, the transmission range can be reduced and accordingly the sending power in order to reduce interferences or radiation exposure of persons staying in the area of the lighting unit or lighting network.

In an advantageous embodiment a substitute master lighting unit is provided which replaces the original master lighting unit in case of a failure. Thus, the network can be operated more reliably. Alternatively, less reliable components can be used which are less expensive.

According to a further embodiment the master lighting unit has an interface by which an access network can be accessed. Particularly, the access network may be an internet network and the interface a web interface. By providing this interface communication outside the lighting network can be established in order to remotely control the light intensity in the lighting network, e.g. from a central control. Further, the range of the network can be increased.

According to an advantageous embodiment external control data provided to a slave lighting unit are stored in the data storage unit of the slave lighting unit in addition to the already existing data or by overwriting the already stored data. Thus, a flexibility of the lighting behaviour can be achieved by providing data adapted to different situations, e.g. summer or winter with different sunshine times.

According to a further embodiment a network is formed which comprises the lighting network, an access network and a server unit. Data are transferred between server unit and lighting unit via at least one master lighting unit, by which a connection can be provided via the access network. Thus, advantageously overall control information can be provided in a server unit. The server unit may be a web server unit which receives the information by a user or via an interface to a further program, e.g. an SAP software. Further, the server unit may be a local control device, such as a laptop or PDA. The overall control information is transferred to at least one master lighting unit. The master lighting unit

creates external control data using the overall control information which are then transmitted from the master lighting unit to one or more slave lighting units.

Particularly by the further program parameters such as desired consumed energy or cost objectives are used for establishing the overall control information.

- 5 According to an advantageous embodiment the ambient data may be used for remote maintenance protocols for individual or groups of lighting units. Further, it may be used for cadastral protocols describing number, position, state of individual lighting units. Further, it may be used for failure notices or for the creation of overall control information.

10 According to an advantageous embodiment a light primary control unit is formed which provides illumination control information to at least one master lighting unit. The illumination control information is based on information provided by the master lighting unit, which again may collect information from dependent slave lighting units, and by central control information, such as the desired illumination scenario. Therefore, for this central control information e.g. the required illumination, the target costs, may be
15 considered. The information collected from the master and slave lighting units may particularly comprise data from movement detectors.

A desired illumination scenario may be e.g. village fair or public holiday.

Further aspects and advantages of the invention are described in relation to accompanying drawings of which show:

- 20 Figure 1: a schematic drawing of the setup of a lighting unit;
Figure 2: a schematic drawing of a lighting network;
Figure 3: a perspective view of a lighting unit.

In Figure 1 a lighting unit 1 comprising several LEDs 2 is depicted. The light intensity of each LED 2 is controlled by a processing unit 3. The processing unit 3 provides an internal
25 control signal 9 to an electrical circuit 7 by which a predetermined current is supplied to an individual LED 2 or a group of LEDs 2.

The internal control signal 9 is particularly bit angle modulated. For this modulation a signal is produced, the binary value of which corresponds to the desired intensity of a single LED 2 or a group of LEDs 2.

5 The processing unit 3 comprises or is connected to an internal or an external data storage unit 5. This data storage unit 5 contains data in relation to the light intensity, particularly the light intensity for a predetermined time interval at each day of a year. The data storage contents can be overwritten. Alternatively, the data storage unit is a read-only memory (ROM).

10 Further, the lighting unit 1 comprises an ambient sensor 4 for measuring an ambient parameter 8. This ambient sensor 4 is particularly a movement detector for measuring a movement within a predetermined range of the lighting unit, e.g. within the light cone defined by the lighting unit 1.

15 Alternatively or additionally, the ambient sensor 4 is a light intensity measuring unit for measuring the light intensity of a single LED 2 or a group of LEDs 2. By comparison with a reference value for the light intensity a deviation to the reference value can be determined and can be corrected. Alternatively or additionally a sensor for measuring a light intensity of a single LED 2 or a group of LEDs 2 is integrated in a reflector unit 30 as depicted in Figure 3

20 The deviation of the intensity from a reference value and a correction of the intensity is in particular controlled and managed by the processing unit 3.

25 Alternatively or additionally the ambient sensor 4 comprises a metering component to measure the power consumption of the lighting unit 1. Therefore according to an advantageous embodiment a counter may be positioned along the connection to the power supply, e.g. in front of a transformer. Thus the power consumption can be supervised, in order to detect e.g. deficiencies leading to a higher power consumption than expected or in order to control the costs.

Alternatively or additionally the processing unit 3 may comprise a metering component for measuring the power consumption, in particular by using a counter as described above.

30 In particular the metering component allows a remote read-out, e.g. comprises an e-metering component.

Further, in particular if a solar power conversion unit with a further energy storing unit is used for powering the lighting unit 1, the amount of energy for the lighting unit 1 for periods where no energy can be converted, e.g. during the night, can be determined. Thus energy not needed may be used otherwise, e.g. for cooling purposes or powering another lighting unit 1.

Alternatively or additionally the processing unit 3 or/ and the ambient sensor may comprise a temperature sensor. The data thereof may be used for controlling the temperature of the lighting unit 1. Thus, for ensuring the desired brightness the lighting unit 1 can be cooled or the current provided to the LED 2 or group of LEDs 2 may be adjusted.

The temperature sensor may be placed in particular in vicinity of the LED 2 or group of LEDs 2 in order to ensure an accurate measurement of the relevant temperature, thus e.g. the temperature sensor may be placed on a PCB (printed circuit board), on which also the LED 2 or group of LED 2 are positioned.

The lighting unit 1 further comprises a local wireless transmission unit 6 for sending or receiving data particularly in a range of less than 300 meters. Via this local wireless transmission unit 6 a network of two or more lighting units can be established. Particularly in case of master lighting units the unit includes an additional GPRS or comparable transmission standards for connecting the lighting unit 1 over longer distances. Thus, the wireless transmission unit comprises at least a module for establishing a connection in a short range, e.g. up to a few hundred meters, and optionally a module for a long range connection, e.g. a wireless telecommunications connection such as e.g. GPRS.

The lighting unit 1 further comprises a time registration device 10 which measures or receives points of time. By using these points of time provided by the time registration device 10 a time interval can be chosen by the processing unit 3 and the light intensity value corresponding to the chosen time interval can be taken from the data storage unit 5.

Particularly, the time registration device 10 can be contained in the processing unit 3. Alternatively, the time registration device 10 may receive points in time by use of the transmission unit 6 adapted for wireless transmission, which are measured externally.

One LED 2 or a group of LEDs 2 form the lighting element 11. The number of LEDs 2 depends on the desired purpose of the lighting unit 1, e.g. for a high desired light intensity a higher number of LEDs 2 may be used. Alternatively or additionally, the number of LEDs 2 depends on height of the lantern from which a certain area on the ground is to be illuminated.

Further, the lighting element 11 may comprise a group of LEDs 2 of the same type. This facilitates the control of the lighting unit, because each of the LEDs has approximately the same characteristics. Alternatively, different types of LEDs may be used in order to achieve a desired colour. Also, LEDs 2 of different brightness might be used. The lighting elements 11 may be set up by an array of LEDs 2, which are arranged immediately neighboured to each other. Alternatively, the LEDs 2 may be distributed on several distinct areas at the lighting unit 1.

If the lighting unit 1 is used for the illumination of a street or a railway station, an LED 2 or a group of LEDs 2 is used which emit light with a high blue fraction, i.e. cool light, e.g. corresponding to a temperature range above circa 3,500 K. This has the advantage that insects are less attracted by this cool light than it would be the case with warmer light.

The lighting unit 1 is contained in a lamp hat. This ensures a compact setup of all components. Alternatively, e.g. for a street lighting the lighting unit may be distributed over the lamp hat and the rod for supporting the lamp hat.

The wireless transmission unit 6 is a transmission unit which works in the regime around 2.4 GHz and uses an encryption of at least 128 bit. This ensures that common wireless transmission units can be used which makes the production cheaper. Further, it ensures that the necessities for establishing a network of street lamps with a limited range between one street lamp and another street lamp are met. Alternatively, other frequency bands are used which are suitable in respect to range, interferences and allowed frequency bands.

According to a further, not depicted embodiment, the transmission unit 6 is adapted - alternatively or additionally - for wired transmission. Thus data between at least one slave lighting unit and at least one master can also be transferred over power cables through power line technology, where they are available and where it is advantageous to use the prescribed fixed structures of the existing fixed network. By using power lines to which a

lighting unit is connected anyway this lines can be used two-fold and no additional network infrastructure has to be provided.

The electrical circuit 7 for driving the LED 2 or a group of LEDs 2 is designed to run alternatively on either DC or AC power.

- 5 In case of AC power input the circuit includes an AC-DC converter followed by a constant current source which can comprise an electronic component for controlling the operating current of a LED 2 or a group of LEDs 2 by using a signal with bit angle modulation other than the pulse width modulation.

10 In case of DC power input the AC-DC converter will be by-passed. This enables the light units to be able to use both DC and AC power for example by using solar and/or wind power in parallel to the general AC network. It is possible that AC power is not needed at all when units are planned to run on DC power networks like the ones for train systems. In this case there will be no need for the AC-DC converter.

15 According to an embodiment a switch is provided in order to select between AC or DC power. Thus, the lighting unit can be used in DC power networks, driven by batteries or solar panels as well as AC power networks.

20 When using bit angle modulation, the LED is driven by a pulse train that is the binary word defining the value of a required intensity. Each bit of the pulse train is stretched by a ratio defined by the binary significance of each bit. Each bit of the binary word is effectively allocated a fixed range of phase angles within the drive cycle. The advantage of bit angle modulation is a simple implementation, and, as the drive signal is a multiple of the modulation frequency, a reducing of potential flicker. Also, because the LED drive signal contains a digital code of the intensity value, other devices may recover the data.

25 According to another embodiment, the lighting unit 1 further comprises a solar panel. By use of the solar panel the energy converted from light may be used in addition to otherwise provided energy in order to drive the LED. Excess energy may be stored by use of batteries also positioned in or at the lighting unit 1. Thus, light energy can be stored e.g. for use during the night or when there is no sunlight.

Additionally or alternatively, the lighting unit 1 comprises a wind energy converter. The power of the wind energy converter is adapted to the power consumption of the lighting unit 1. A wind energy converter can be used e.g. when there is no sunlight.

5 According to another advantageous embodiment the processing unit 3 controls the use of wind and solar energy.

In Figure 2 a schematic drawing of a network 26 comprising a lighting network 20 is depicted. The lighting network 20 comprises one or more master lighting units 21 and one or more lighting units 1 which act as slave lighting units.

10 A master lighting unit 21 is used for establishing a connection to a remote control. Therefore, a master lighting unit 21 has a module for a long range connection, e.g. a wireless telecommunication module.

Each lighting unit 1 has a unique identification number and has access to the two or more following and two or more preceding units. A master lighting unit 21 provides external control information 23 to lighting units 1 which are therefore denoted as slave lighting units. The lighting units 1 transmit the information 23 as 231 to the next neighbours and so on. The transmission stops if specified or continues until the forwarded information arrives back at the master lighting unit 21. Preferably, information or external control data 23 are transmitted between neighbored lighting units 1 or between a neighbored master lighting unit 21 and a lighting unit 1. Alternatively or additionally, data are transmitted from the master lighting unit 21 to each slave lighting unit. Any information 23 is coded for one specific lighting unit 1 by its identification number or for all lighting units 1 in the local area network. Since some lighting units 1 may be in far distance from the master unit the information is being sent to the next two units and they forward the external control information 23 as forwarded external control information 231 to the next neighbours until the information is being received by the respectively addressed identification number. Alternatively, the process can start in the other direction.

Alternatively or additionally to transmitting data between only the nearest lighting units 1, i.e. the respective lighting units that have the smallest distance to each other, the data may be exchanged between all neighbored lighting units or at least a group of all the lighting units 1 which are positioned within the transmission range, wherein the lighting units to which a transmission takes place can be defined user or situation dependently.

For compensating a possible failure of a master lighting unit 21 a substitute master lighting unit 22 is provided. The function of the substitute master lighting unit is as follows: the processing unit 3 of the substitute master lighting unit 22 monitors if external control data 23 from the master lighting unit 21 is received with a certain rate. If no external control data are received for a set time interval, the substitute master lighting unit 22 starts a test signal to find out whether this is due to a failure of a neighbored slave lighting unit or due to the failure of the master lighting unit 21. If it is found that it is due to a failure of the master lighting unit 21, the substitute master lighting unit 22 takes the position of the master lighting unit 21 by activating its interface 24 to an access network 25.

Alternatively, the master lighting unit 21 may send a signal indicating its failure upon which the substitute master lighting unit 22 takes over.

A master lighting unit 21 has in addition to a normal or slave lighting unit 1 an interface 24 for accessing an access network 25 by which data can be transferred to a server unit 27. This interface 24 is particularly the module for establishing a long range connection. Thus, overall control information 28 for controlling the whole lighting network 20 can be provided from a server unit 27 via the access network 25 to each or some, at least one, of the master lighting units 21. The master units can alternatively be accessed by a local control master (laptop, PC, PDA, etc.) (not shown). Both local control master and server 27 can initiate communication process particularly via an SMS signal which can also be received by the master lighting unit 21.

A possible embodiment of a function of the network 26 when using a movement detector as ambient sensor 4 is provided below:

By the movement detector as ambient sensor 4 a movement is measured as ambient parameter 8 within the light cone of a street lamp or lantern. This movement takes place within a predetermined time interval, e.g. 10 seconds, which is either originally provided in the data storage unit 5 or set by the master lighting unit 21 by sending external control data. This time interval may be adapted to the required situations. E.g. for an illumination at a railway station, where fast moving objects are to be detected, a shorter time interval than for example for streets might be used.

The sensitivity for a movement within the light cone is set such that neither small animals, such as moths, birds, cats or dogs, nor oscillating movements, such as moving trees or

bushes are detected. By using the measurements of the neighbored lighting units 1, which all transfer their movement measurements as ambient parameter 8 to their local memory storage or data storage unit 5 and can deliver the data by request to a master lighting unit 21, a direction and velocity of the movement can be determined, and the master lighting unit 21 can send corresponding external control data 23 to ensure a desired illumination, e.g. bright illumination, along the direction of the movement with the corresponding velocity.

This movement detection can take place either in a predetermined time interval, e.g. during the night when the illumination is normally off, or during the whole 24 hours. Further, a distinction between working days and weekends may be provided. A change of brightness from 0 to 100% of the maximum intensity or vice versa may be provided as well as a change between different dimming levels, e.g. 25%, 50 %, 75 % of the maximum intensity etc.

A further example for a chain of action is given for a light intensity detector as ambient sensor 4. The light intensity of the lighting element 11 or at least one individual LED 2 is determined in a predetermined range from the lighting element 11 or the LED 2. In a control circuit, a deviation between the reference value describing the desired light intensity and the actually measured light intensity is determined. The deviation is determined in multiples of a certain unit, e.g. 5%, in order not to initiate any close loop control for very small deviations which would lead to instabilities. If the measured deviation is within a certain range, e.g. 10 to 15%, the individual lighting unit 1 may compensate this by providing different driving parameters by the electrical circuit 7 to the individual LED or the whole lighting element 11.

For higher deviations this deviation information is provided from the slave lighting unit to the master lighting unit 21 which communicates this to the server unit 27 in order to provide data for maintenance of the lighting network 20.

According to another embodiment an anti-theft detector is used as ambient sensor 4. The anti-theft sensor supervises any removal or destruction of parts of the lighting unit 1. In case a removal or destruction is detected, a signal is provided by the anti-theft detector and transmitted towards the master lighting unit 21 by use of the wireless transmission unit 6. This further facilitates the maintenance of lighting network 20.

According to another embodiment the ambient sensor 4 comprises alternatively or additionally to the movement detector or/and light intensity detector or/and anti-theft detector a device or counter for determining the power consumption. Data in regard to the power consumption are provided by the lighting unit 1, eventually via further neighbored lighting units 1 to the master lighting unit 21, access network 25 and server unit 27. Overall control data 28 are created and transmitted for controlling the power consumption in the lighting unit 1 or for distributing the power from the lighting unit 1 to a cooling device of that lighting unit 1 or to at least one further lighting unit 1.

Alternatively or additionally the processing unit 3 comprises alternatively or additionally to the movement detector or/and light intensity detector or/and anti-theft detector a device or counter for determining the power consumption.

In particular, the ambient sensor 4 or components thereof, e.g. the metering device, may be integrated in the processing unit 3.

A particular advantage of the described network 26 is that the control of the lighting network 20 is realised via at least one master lighting unit 21 instead of controlling each individual lighting unit 1 separately. Thus, the master lighting unit 21 provides data of all related slave lighting units, so that the master lighting unit 21 and the related slave lighting units form a single virtual light unit.

According to a further embodiment, each lighting unit 1, master lighting unit 21 and substitute master lighting unit 22 has an identification number. Further, in the data storage unit 5 an identification number of at least two neighbored lighting units 1 is stored, i.e. the processor and successor. A signal which is dedicated to a specific lighting unit 1 or all lighting units 1 is sent from the master lighting unit 21 first to the directly neighbored lighting unit 1 and also to the next following neighbour in case any unit is not working well. This neighbored lighting unit 1 then transmits a message to its successor, and transmits back to the master lighting unit 21 a confirmation about the successful or unsuccessful transmission. In this way the message is transmitted from lighting unit 1 to lighting unit 1 until it arrives back at the master lighting unit 21. This procedure is either repeated until it is performed without an error or an error message is send to the master lighting unit.

The above described embodiments can be combined or some of their features may be combined. Particularly, several ambient detectors 4 are used and the control of the light intensity considers the respective ambient detector signal.

5 Additionally, the ability to control a multitude of such local networks through a global network combining all at least one local network into one global network acting as one entity being wirelessly connected through the web, or internet, and collectively managed by one central server is realised.

Such a network may be particularly applied for a central control of individual lighting units at train platforms, railway tracks or railway freight depots.

10 Particularly illumination data of a lamp can be supervised and analysed. Therefore, an individual lighting unit sends as ambient parameter the required illumination data, e.g. duration of illumination time in predetermined time intervals to a master lighting unit, which collects these data from various lighting units and transmits this information further to a central entity such as the server unit 27 or a maintenance computer. Alternatively or
15 additionally, this information may be received by polling the lighting units.

In Figure 3 a perspective view of a lighting unit 1 is depicted. The LEDs are contained in a housing which comprises ribs 29 for dissipating heat. Further, it comprises a reflector 30 for reflecting the light emitted by the LEDs or group of LEDs such that at a predefined distance from the LED or group of LEDs or the lighting unit, a uniform illumination is
20 achieved.

Thus, particularly the present invention relates to a wireless connected network (a WLAN wireless local area network between lighting units on one geographic area) comprising at least one lighting unit acting as a master lighting unit and at least one lighting unit acting as a slave lighting unit collectively connected to a central server through the web (GAN
25 global area network) or to a master controlling unit being installed on a laptop or PC located particularly in less than 300 meters distance. The connection to the web or internet or other networks, e.g. private LANs etc, or to the master controlling unit is wireless. Each lighting unit is not further than 300 meters from each other.

According to a further embodiment, which is not depicted, the at least one master lighting
30 unit 21 and the at least one slave lighting unit 1 and – optionally the substitute slave

lighting units 22 are equipped with a wireless transmission unit and the communication between them is realised wirelessly. Additionally the master lighting units 21 and substitute master lighting units 22 are equipped with a transmission unit for wired connection, particularly a connection via power line or fixed communication network. The connection to the access network is realised via the wired connection.

This embodiment allows a high flexibility in positioning the individual lighting units 1, substitute lighting units 22 and master lighting units 21, because already predetermined fixed structures have not to be used. On the other hand an effective long range communication to the access network can be established which is resistant in regard to disturbances.

According to a further embodiment, which is not depicted, the at least one master lighting units 21, the at least one slave lighting units 1 and -- optionally the substitute slave lighting units 22 are equipped with a wired transmission unit and the communication between them is realised via a wired connection, particularly a power line communication. Additionally the master lighting units 21 and substitute master lighting units 22 are equipped with a transmission unit for wireless connection and the connection to the access network is realised via the wired connection. Alternatively the master lighting units 21 and substitute master lighting units 22 are equipped with a transmission unit for long range wired connection and the connection to the access network is realised via the long range wired connection, e.g. a fixed communication network. These set-ups have the advantage that radiation exposure in the area of the lighting units can be avoided.

According to another embodiment a master lighting unit 21 comprises one or more transmission units, e.g. at least one master lighting unit 21 or each master lighting unit is equipped with a module for GPRS or/and UMTS transmission. In particular, the master lighting unit 21 may have one or more different transmission units 6, which may be managed by the processing unit 3 or/and remotely. At least one slave lighting unit 1 is equipped with one or more transmission units, e.g. the slave lighting unit 1 is equipped with a module for WLAN standards such as Zig Bee or/and WiFi transmission and/or other alternatives, e.g. Bluetooth. An advantage thereof is to provide an efficient long range communication via the telecommunication technologies established in the area of the lighting network 20 particularly in order to receive/ send information to the access network and/or the server unit 27. Thus the access to the network 20 via e.g. an internet

connection in order to request or provide information, in particular to request internal control signals 9 or measured ambient parameters 8 or to provide overall control information 28, is realised with a high area coverage. In particular information can be requested or provided to the network via a mobile connection such as mobile WiFi, which
5 is in particular advantageous for additional services such as VoIP (voice over IP) , conferencing and other internet based services in addition to light services. In order to establish desired security measures, the access to the network 20 via a mobile internet connection may in particular be controlled by centrally, e.g. by the server unit 27.

In particular the transmission unit 6, which is adapted for wireless transmission, such as a
10 WiFi component, may comprise a sender or/and receiver. Additionally the transmission unit 6 may comprise further elements, such as a router or/and processor or/and a memory for storing data. This has the advantage, that commercially available transmission units 6 may be used.

Further a high flexibility of the layout of the network 20, e.g. the positioning of the slave
15 street lamps, is ensured by using the established short range transmission standards.

In particular if a master lighting unit 21 or a slave lighting unit 1 is equipped with more than one transmission unit, the latter can be chosen e.g. in regard to the covering of the area in regard to the respective transmission, possible interferences with other transmissions that exist in this area or power demand. The transmission module to be used
20 is in particular activated by using overall control information 28 provided to the master street lamp 21. The transmission units may each be switched off/on based on functional or customer needs.

For a high flexibility in choosing the most appropriate transmission mode, the master lighting unit 21 and/or the slave lighting units and/or the substitute master lighting units 22
25 may be equipped with more than one transmission module 6.

Alternatively in order to keep the production costs low the master lighting unit 21 and/or the slave lighting units and/or the substitute master lighting units 22 are equipped with at least one transmission module.

In particular if a hierarchical structured transmission such as ZigBee is used, a substitute master lighting unit 22 may be used as coordinator in case of failure of a master lighting unit.

5 Thus, the invention also relates to a network, which is -- at least partially - connected via a wired connection for transfer of signals from and to at least one lighting unit and at least one master lighting unit and/or an access network. This wired connection is particularly established by using the power line across which the internal control signals and/or external control signals are sent.

List of Reference Numbers

- 1 lighting unit
 - 2 LED
 - 3 processing unit
 - 5 4 ambient sensor
 - 5 data storage unit
 - 6 transmission unit
 - 7 electrical circuit
 - 8 ambient parameter
 - 10 9 internal control signal
 - 10 time registration or scheduling device in CPU
 - 11 lighting element
 - 20 lighting network
 - 21 master lighting unit
 - 15 22 substitute master lighting unit
 - 23 external control data
 - 24 interface
 - 25 access network
 - 26 network
 - 20 27 server unit
 - 28 overall control information
 - 29 ribs
 - 30 reflector
 - 31 forwarded external control information
- 25

Claims

1. Lighting unit (1, 21, 22) comprising

a) a lighting element (11) comprising at least one LED (2);

b) a processing unit (3) for controlling the light intensity of the at least one LED (2);

c) an ambient sensor (4) for measuring at least one ambient parameter (8) within a predetermined range of the lighting unit (1, 21, 22);

d) a data storage unit (5) containing at least one light intensity value for a predetermined period of time connected with a time value;

e) a time registration device (10) for providing a time value;

wherein the processing unit (3) is adapted such that

- one of the at least one light intensity values is chosen depending on the provided time value and

- the light intensity is controlled on basis of the chosen light intensity value and the at least one measured ambient parameter (8).

2. Lighting unit (1, 21, 22) according to claim 1 further comprising a transmission unit (6) for receiving and/or sending data.

3. Lighting unit (1, 21, 22) according to claim 1 or 2 wherein the ambient parameter (8) is used for an open loop control or a closed loop control of the light intensity.

4. Lighting unit (1, 21, 22) according to any of the previous claims wherein the ambient sensor (4) is a movement detector for detecting a movement within a predetermined range of the lighting unit (1) or/and a detector for measuring the light intensity of the at least one LED (2) or/and the lighting element (11) at a predetermined position.

5. Lighting unit (1, 21, 22) according to any of the previous claims wherein the processing unit (3) provides an internal control signal (9) to an electrical circuit (7) for controlling the light intensity of the lighting element (11) or/and the at least one LED (2), wherein the internal control signal (9) is bit angle modulated.
- 5 6. Lighting unit (1, 21, 22) according to any of the claims 1 to 5 wherein the transmission unit is adapted for wireless and/or wired transmission.
7. Lighting unit (1, 21, 22) according to claim 6, wherein the lighting unit is adapted for power line communication as wired transmission.
8. Lighting unit (1, 21, 22) according to any of the previous claims, wherein the
10 ambient sensor (4) or/and the processing unit (3) comprises a metering device for measuring a current provided to the lighting unit (1, 21, 22) or/ and a power consumption of the lighting unit (1, 21, 22).
9. Lighting unit (1, 21, 22) according to claim 8, further comprising a counter, which is positioned along the connection to a power supply.
- 15 10. Lighting unit (1, 21, 22) according to claims 8 or 9, the metering device being adapted for a remote read-out.
11. Lighting unit (1, 21, 22) according to any of the previous claims, wherein the ambient sensor (4) is at least partially integrated in the processing unit (3).
12. Lighting unit (1, 21, 22) according to any of the previous claims, further
20 comprising a reflector unit (30) with a reflector for each LED (2) or group of LEDs (2).
13. Lighting unit (1, 21, 22) according to claim 12, wherein at least a part of the ambient sensor (4) or /and at least a part of at least one further sensor is integrated in the reflector unit (30), in particular a sensor for measuring a light intensity of a
25 LED (2) or group of LEDs (2).
14. Lighting network (20) comprising at least two lighting units (1, 21, 22) according to any of the previous claims 2 to 13, wherein

- data are transferrable between the at least two lighting units (1, 21, 22) by use of the transmission units (6) and
 - one of the at least two lighting units (1, 21, 22) is adapted as master lighting unit (21) providing external control data (23) for controlling the light intensity to the other of the at least two lighting units (1, 21, 22) adapted as slave lighting unit (1);
- 5
15. Lighting network (20) according to claim 14 wherein the transmission unit (6) and the processing unit (3) of the master lighting unit (21) is adapted such that
- at least one ambient parameter (8) from at least one slave lighting unit (1) is received;
 - external control data (23) are created; and
 - external control data (23) are sent to the at least one slave lighting unit (1).
- 10
16. Lighting network (20) according to claim 14 or 15 wherein the processor unit (6) of the at least one master lighting unit (21) is adapted such that
- external control data (23) are created by using an ambient parameter or/and using overall control information (28).
- 15
17. Lighting network (20) according to any of the previous claims 14 to 16 wherein the lighting network (20) comprises a ring of lighting units (1, 21, 22) and wherein data are transferrable from a lighting unit (1, 21, 22) to a neighboured lighting unit (1, 21, 22).
- 20
18. Lighting network (20) according to any of the previous claims 14 to 17 wherein at least one substitute master lighting unit (22) is provided which acts as slave lighting unit (1) as long as the original master lighting unit (21) works and which acts as master lighting unit if the original master lighting (21) unit fails.
- 25
19. Lighting network (20) according to any of the previous claims 14 to 18 wherein the at least one master lighting unit (21) further comprises an interface (24) for accessing an access network (25), particularly a web interface for an internet network.

20. Lighting network (20) according to any of the previous claims 14 to 19, wherein the processing unit (6) of the at least one slave lighting unit (1, 22) is adapted such that external control data (23) provided by the master lighting unit (21) are stored in the data storage unit (5) of the at least one slave lighting unit (1,22).
- 5 21. Network (26) comprising a lighting network (20) according to any of the previous claims 14 to 20, an access network (25) and a server unit (27), wherein data are transferred between the lighting network (20) and the server unit (27) via the at least one master lighting unit (21) and the access network (25).
- 10 22. Network (26) according to claim 21, wherein overall control information (28) for controlling the light intensity of a light network (20) is transmitted from a web server unit (27) via the internet to the at least one master lighting unit (21).
- 15 23. Network (26) according to claims 21 or 22, wherein the at least one slave lighting unit (1) is provided with a transmission unit (6) for either wired or wireless transmission and the master lighting unit (21) is provided with a transmission unit (6) for either the other of wireless or wired transmission.
24. Network (26) according to claims 21 or 22, wherein the at least one slave lighting unit (1) is provided with a transmission unit (6) for either wireless or wired transmission and the master lighting unit (21) is provided with a transmission unit (6) adapted for wireless and wired transmission.
- 20 25. Network (26) according to any of the claims 21 or 22, wherein the slave lighting unit (1) and the master lighting unit (21) are equipped with a transmission unit (6) for wireless or/and wired transmission.
- 25 26. Network (26) according to any of the claims 21 to 25, wherein the at least one slave lighting unit (1) or/ and the at least one master lighting unit (21) or/ and the at least one substitute master lighting unit (22) is provided with one or more transmission units (6).
- 30 27. Network (26) according to claim 26, wherein the at least one master lighting unit (21) and/or the at least one substitute slave lighting unit (22) is provided with a transmission unit (6) for UMTS or/and GPRS and WLAN transmission, in particular ZigBee or/and WiFi.

28. Network (26) according to claim 26 or 27, wherein the at least one slave lighting unit (1) is provided with a transmission unit (6) for WLAN transmission, in particular for ZigBee or/and WiFi or/and alternatives.

5 29. Network (26) according to any of the claims 26 to 28, wherein at least one transmission unit (6), in particular a transmission unit (6) for WLAN transmission, is used further for at least one internet service, in particular voice over IP or conferencing.

10 30. Method for controlling the light intensity of a lighting network comprising at least one master lighting unit (21) and at least one slave lighting unit (1) comprising the following steps:

- providing overall control information (28) in a server unit (27);
- transmitting said overall control information (28) to the at least one master lighting unit (21);
- creating external control data (23) in the at least one master lighting unit (21) or
15 local control device using the overall control information (28);
- transmitting external control data (23) from the at least one master lighting unit (21) to at least one slave lighting unit (1).

1/2

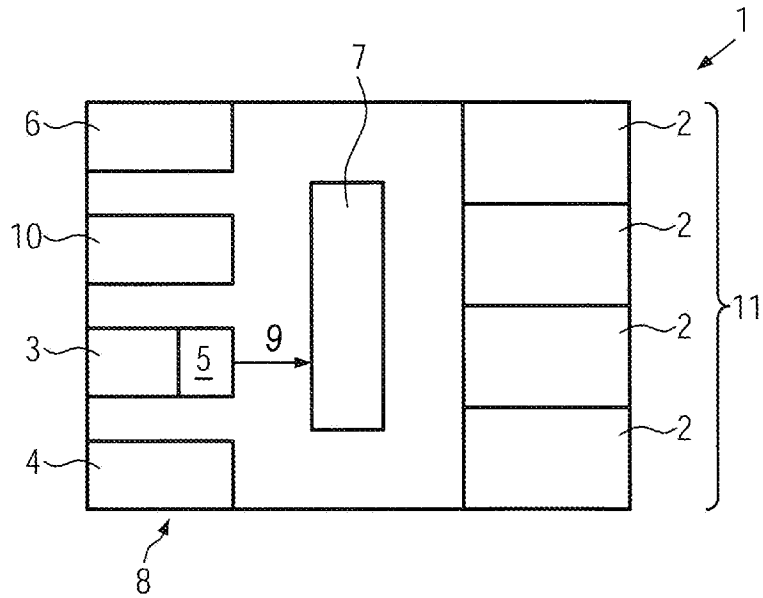

FIG. 1

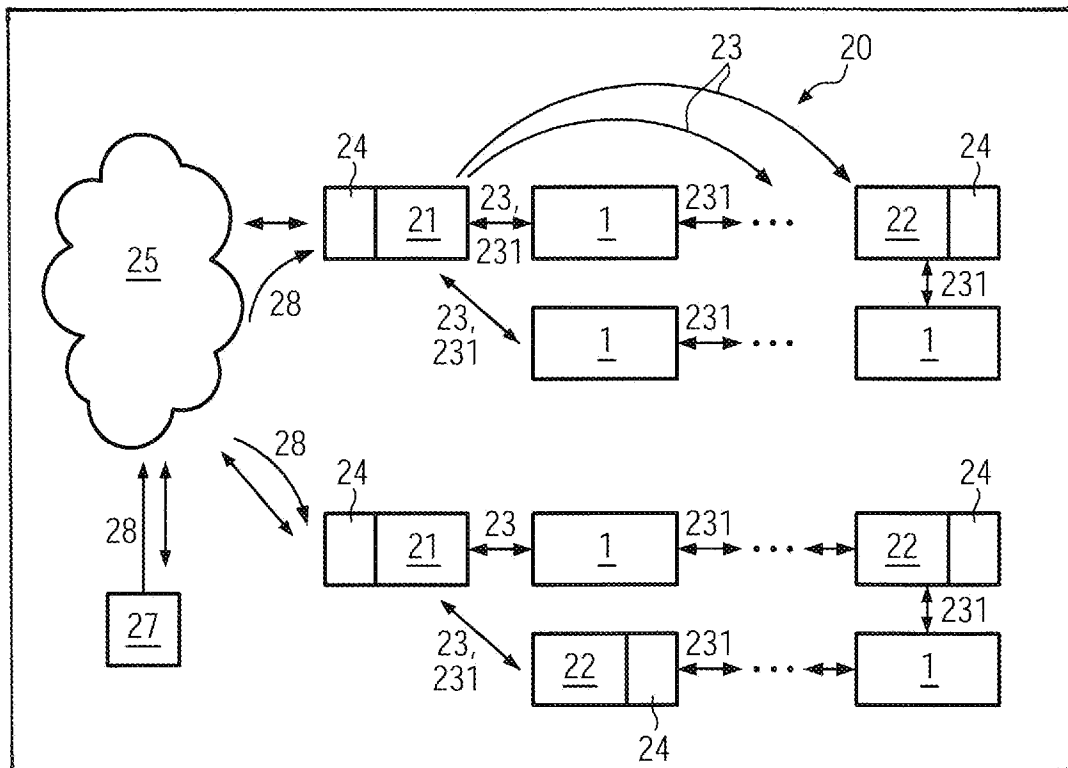

FIG. 2

2/2

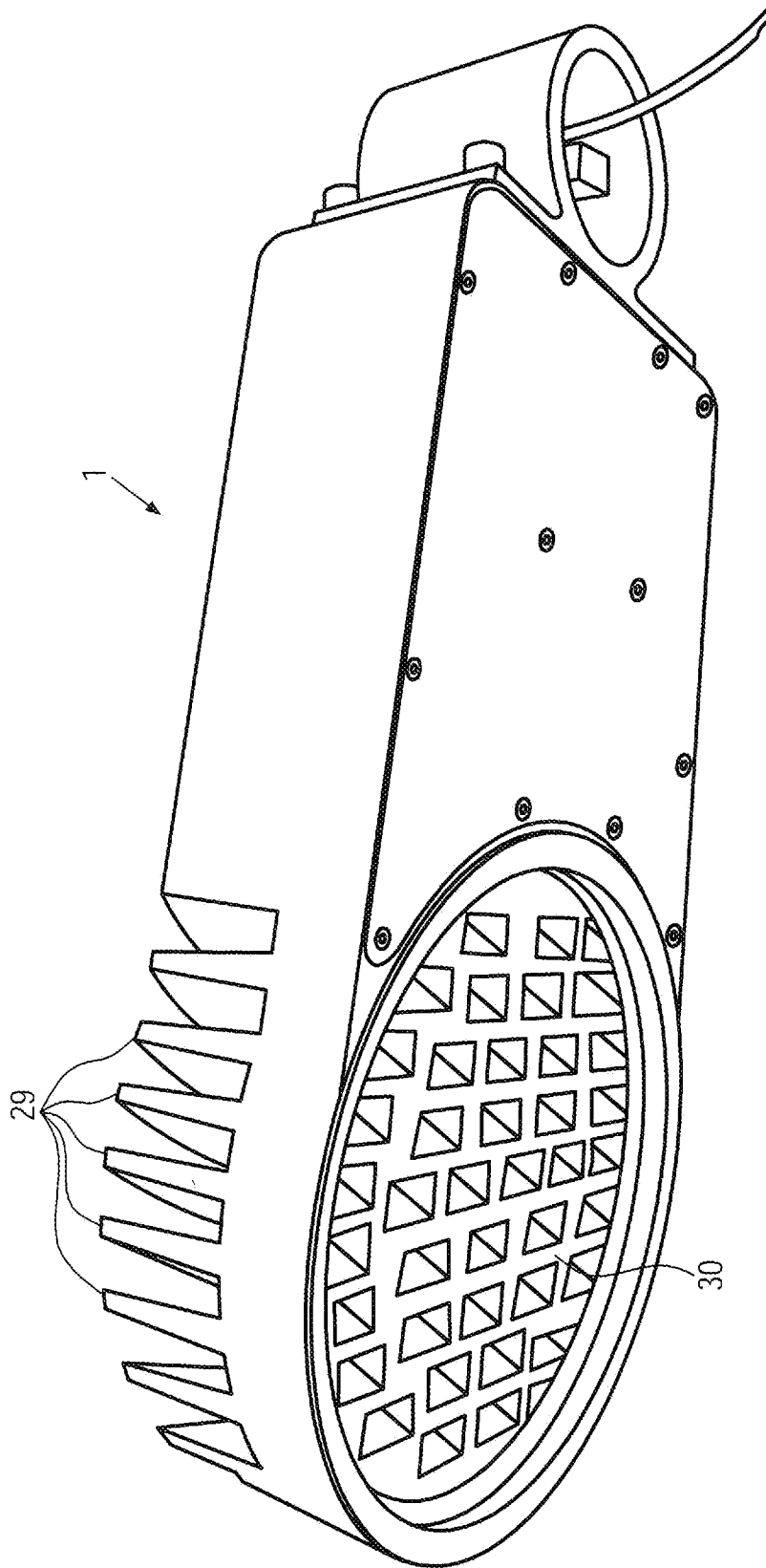

FIG. 3