

(19) World Intellectual Property Organization  
International Bureau



(43) International Publication Date  
29 January 2004 (29.01.2004)

PCT

(10) International Publication Number  
WO 2004/009160 A1

- (51) International Patent Classification<sup>7</sup>: A61M 5/142, F16K 7/04
- (74) Agent: **BUDDE, SCHOU & OSTENFELD A/S**; Vester Søgade 10, DK-1601 Copenhagen V (DK).
- (21) International Application Number: PCT/DK2003/000507
- (81) Designated States (*national*): AE, AG, AL, AM, AT (utility model), AT, AU, AZ, BA, BB, BG, BR, BY, BZ, CA, CH, CN, CO, CR, CU, CZ (utility model), CZ, DE (utility model), DE, DK (utility model), DK, DM, DZ, EC, EE (utility model), EE, ES, FI (utility model), FI, GB, GD, GE, GH, GM, HR, HU, ID, IL, IN, IS, JP, KE, KG, KP, KR, KZ, LC, LK, LR, LS, LT, LU, LV, MA, MD, MG, MK, MN, MW, MX, MZ, NI, NO, NZ, OM, PG, PH, PL, PT, RO, RU, SC, SD, SE, SG, SK (utility model), SK, SL, SY, TJ, TM, TN, TR, TT, TZ, UA, UG, US, UZ, VC, VN, YU, ZA, ZM, ZW.
- (22) International Filing Date: 21 July 2003 (21.07.2003)
- (25) Filing Language: English
- (26) Publication Language: English
- (30) Priority Data: PA 2002 01133 24 July 2002 (24.07.2002) DK
- (84) Designated States (*regional*): ARIPO patent (GH, GM, KE, LS, MW, MZ, SD, SL, SZ, TZ, UG, ZM, ZW), Eurasian patent (AM, AZ, BY, KG, KZ, MD, RU, TJ, TM), European patent (AT, BE, BG, CH, CY, CZ, DE, DK, EE, ES, FI, FR, GB, GR, HU, IE, IT, LU, MC, NL, PT, RO,
- (71) Applicant (*for all designated States except US*): **M 2 MEDICAL A/S** [DK/DK]; Mesterladden 42, DK-2820 Gentofte (DK).
- (72) Inventor; and
- (75) Inventor/Applicant (*for US only*): **MERNØE, Morten** [DK/DK]; Høstvej 21, DK-2920 Charlottenlund (DK).

[Continued on next page]

(54) Title: AN INFUSION PUMP SYSTEM, AN INFUSION PUMP UNIT AND AN INFUSION PUMP

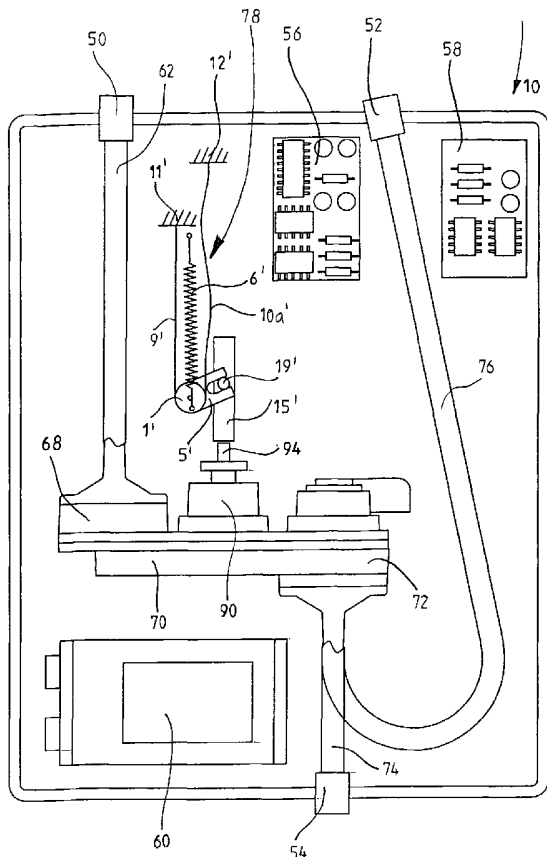

(57) Abstract: An infusion pump unit, comprising a housing of a size allowing the pump unit to be carried by a user as a portable infusion pump unit, a fluid inlet 50 for establishing fluid communication from an external infusion bag to said fluid inlet, a fluid outlet 52 for establishing fluid communication to an infusion site, a controllable pumping system 90 for pumping fluid from the fluid inlet 50 to the fluid outlet 52 and a shape memory alloy actuator 78 for operating the pumping unit, the actuator 78 comprising a pivotable body 1' having a yoke 5' for displacing an actuator means 15' linearly when the body 1' pivots under the influence of two shape memory alloy wires 9' and 10a' and a tension spring 6' such that alternative heating and cooling of the shape memory wires 9' and 10a' reinforced by the action of the spring 6' pivots the body 1' to and fro.

WO 2004/009160 A1



SE, SI, SK, TR), OAPI patent (BF, BJ, CF, CG, CI, CM, GA, GN, GQ, GW, ML, MR, NE, SN, TD, TG).

*For two-letter codes and other abbreviations, refer to the "Guidance Notes on Codes and Abbreviations" appearing at the beginning of each regular issue of the PCT Gazette.*

**Published:**

— *with international search report*

## AN INFUSION PUMP SYSTEM, AN INFUSION PUMP UNIT AND AN INFUSION PUMP

5 The present invention generally relates to the technical field of infusing a liquid to a patient or person by means of an infusion pump, e.g. at a hospital. The present invention also relates to infusion of liquid to an animal. More precisely, the present invention relates to an infusion pump system and an infusion pump unit of a universal applicable structure for infusing a liquid into a patient or person.

10

At hospitals or nurse houses, it is often necessary to supply medication or body liquids to a person by means of an infusion pump in which instance the medication or the body liquids are infused into the body of the patient or person in question through a catheter which is connected to the blood transportation system of the patient or  
15 person, e.g. a vein or a venule. The usual technique of supplying medication by means of an infusion system to a patient or person involves the supply of physiologic liquid to the patient which physiologic volume is supplied at a specific rate and which serves as a diluting liquid as the medication is supplied to the physiologic liquid also at a specific rate such as one or two drops of medication per time period varying from a second or  
20 a few seconds to several minutes or even hours. The medication of a patient or person may in some applications involve the supply of the medication directly to the patient or person by means of the infusion pump.

US patent No. 6,270,478 discloses an infusion pump system allowing the patient or  
25 person using the infusion pump system to shift from a position sitting or lying in a bed and move around without necessitating the substitution or shift of the stationary infusion pump to a portable infusion pump as the infusion pump system constitutes a universally applicable or combined portable and stationary infusion pump system.

30 An advantage of this known system relates to the fact that the infusion pump system may be used in different pumping modes as the infusion pump system includes several programmes for different operational modes and further preferably includes input means for input of different operational programmes. US patent No. 6,270,478 is hereby incorporated herein by reference.

35

The pump actuator of the infusion pump units of this known system comprises a magnetic core and a solenoid coil. This actuator is rather bulky, noisy and heavy and requires a relatively large input of electrical energy.

- 5 It is an object of the present invention to provide an infusion pump system, an infusion pump unit for said system and an infusion pump in general where the pump actuator is lighter, smaller, quieter and less power consuming.

According to one aspect of the invention this object is achieved by providing a shape memory alloy actuator as the pump actuator, and said shape memory actuator  
10 comprises:

- a body arranged displaceable between a first and a second position,
- releasable holding means adapted for holding said body in said first position,
- at least one first and at least one second wire made of a shape memory alloy  
15 such as nitinol, said first wire being at one end connected to said body such that shortening of the length of said first wire exerts a force on said body for moving said body from said second to said first position, and
- a biasing means, such as a tension spring, a compression spring, a straight or arcuate flat spring or a piston and cylinder mechanism, arranged and adapted  
20 for biasing said body for moving said body from said first to said second position,
- said second wire having one end connected to said holding means such that shortening of the length of said second wire releases said holding means for  
25 allowing said biasing means to move said body from said first position to said second position.

According to another aspect this object is obtained by providing a shape memory alloy actuator as the pump actuator, and said shape memory actuator comprises:

- a body arranged displaceable between a first and a second position,
- 30 - at least one first wire made of a shape memory alloy such as nitinol, said first wire being at one end connected to said body such that shortening of the length of said first wire exerts a force on said body for moving said body from said second to said first position,
- a biasing means, such as a tension spring, a compression spring, a straight or  
35 arcuate flat spring or a piston and cylinder mechanism, and

- a rotatably arranged intermediate member such as a lever or a disc connected to said body and to said biasing means,  
said biasing means being adapted for exerting a rotation force on said intermediate member for rotating said intermediate member around an axis of rotation in a first direction of rotation from a first angular position to a second angular position, said intermediate member being connected to said body such that rotation of said intermediate member in said first direction of rotation displaces said body from said first position to said second position, and  
said biasing means and said intermediate member being arranged and adapted such that the lever or moment arm of said rotation force with respect to said axis of rotation is larger when said intermediate member is in said second angular position than when said intermediate member is in said first angular position such that said lever or moment arm of said rotation force increases when said intermediate member rotates in said first direction of rotation.

15

According to a yet further aspect of the invention this object is achieved by providing a shape memory alloy actuator as the pump actuator, and said shape memory actuator comprises:

- a body arranged displaceable between a first and a second position,
- at least one first wire made of a shape memory alloy such as nitinol, said first wire being at one end connected to said body such that shortening of the length of said first wire exerts a force on said body for moving said body from said second to said first position,
- a biasing means, such as a tension spring, a compression spring, a straight or arcuate flat spring or a piston and cylinder mechanism, and
- a rotatably arranged intermediate member such as a lever or an arm connected to said body at a force transmission point on said body and connected to or integral with said biasing means,

said biasing means being adapted for exerting a rotation force on said intermediate member for rotating said intermediate member around an axis of rotation in a first direction of rotation from a first angular position to a second angular position, said intermediate member being connected to said body such that rotation of said intermediate member in said first direction of rotation displaces said body in from said first position to said second position, and

said intermediate member and said body being arranged and adapted such that said rotation force is transmitted to said body as a displacement force applied at said force

transmission point for moving said body from said first to said second position, and such that the lever or moment arm of said displacement force with respect to said axis of rotation is larger when said intermediate member is in said first angular position than when said intermediate member is in said second angular position such that said  
5 lever or moment arm of said displacement force with respect to said axis of rotation

Hereby a quiet, light, mechanically efficient and compact infusion pump is obtained.

In a yet further aspect the present invention relates to a fluid pump, preferably for use  
10 in an infusion pump system, an infusion pump unit or as an infusion pump, said fluid pump comprising:

- a flexible tube connected to a fluid inlet at one end and connected to a fluid exit at the opposite end,
- at least three flattening bodies for flattening said tube against an abutment element  
15 and arranged along the length of said tube, said bodies being arranged displaceable between a first position, wherein said body is pressed against said abutment element with said tube flattened between said body and said abutment element, and a second position spaced so far from said abutment element that said tube at least partly has regained an open configuration,
- 20 - at least one first wire for each flattening body and made of a shape memory alloy, said first wire being at one end connected to said body such that shortening of the length of said first wire exerts a force on said body for moving said body from said first to said second position, and
  - a biasing means, such as a tension spring, a compression spring, a straight or  
25 arcuate flat spring or a piston and cylinder mechanism, for each of said flattening bodies and connected to said flattening body such that a biasing force is exerted on said flattening body in a direction from said second position to said first position.

Hereby an exceptionally light, simple and quiet infusion pump is obtained where the  
30 elements that are to be replaced for each infusion are relatively inexpensive and easy to replace.

In a yet further aspect the present invention relates to an infusion pump for infusing a fluid or a paste in a patient, preferably a portable infusion pump and preferably for use  
35 in infusing insulin or a pain killer fluid in a patient, said infusion pump comprising:

- a housing,
- a cartridge, ampoule or syringe containing said fluid or paste and removably arranged in said housing and having an outlet aperture and a piston element slidably arranged inside said syringe such that said piston is displaceable towards said outlet  
5 aperture,
- a spindle connected to said piston element and arranged such that rotation of said spindle in a first rotational direction displaces said piston towards said outlet aperture
- a shape memory alloy actuator incorporated in a shape memory alloy motor comprising:  
10 - said shape memory alloy actuator having:
  - a body arranged displaceable between a first and a second position,
  - at least one first wire made of a shape memory alloy such as nitinol, said first wire being at one end connected to said body such that shortening of the length of said first wire exerts a first displacement force on said body for  
15 moving said body from said second to said first position,
  - a biasing means, such as a tension spring, a compression spring, a straight or arcuate flat spring or a piston and cylinder mechanism arranged and adapted for exerting a second displacement force on said body for moving said body from said first to said second position,  
20 and
- a gear having a first and second rotation direction,  
said body having a portion adapted to fit between two adjacent teeth of said gear, and  
said body and said gear being adapted and arranged such that in said first position  
said portion is located between a pair of teeth of said gear and in said second position  
25 said portion is located between the adjacent pair of teeth of said gear reckoned in said second rotation direction of said gear such that said second displacement force will cause said body to rotate said gear in said first direction, and  
said gear being connected to said spindle, preferably via at least one further gear such  
that rotation of said gear in said first direction causes said spindle to rotate in said first  
30 rotational direction.

In a yet further aspect the present invention relates to an infusion pump for infusing a fluid or a paste in a patient, preferably a portable infusion pump and preferably for use in infusing insulin or a pain killer fluid in a patient, said infusion pump comprising:

- 35
- a housing,

- a cartridge, ampoule or syringe containing said fluid or paste and removably arranged in said housing and having an outlet aperture and a piston element slidably arranged inside said syringe such that said piston is displaceable towards said outlet aperture,
- 5 - said shape memory alloy actuator, having
  - a body arranged displaceable between a first and a second position,
  - at least one first wire made of a shape memory alloy such as nitinol, said first wire being at one end connected to said body such that shortening of the length of said first wire exerts a first displacement force on said body for  
10 moving said body from said second to said first position,
  - a biasing means, such as a tension spring, a compression spring, a straight or arcuate flat spring or a piston and cylinder mechanism arranged and adapted for exerting a second displacement force on said body for moving said body from said first to said second position,
- 15 and
  - a rack having a first and second displacement direction and abutting said piston such that displacement of said rack in said second displacement direction displaces said piston towards said outlet aperture,  
said body having a portion adapted to fit between two adjacent teeth of said rack, and  
20 said body and said rack being adapted and arranged such that in said first position said portion is located between a pair of teeth of said rack and in said second position said portion is located between the adjacent pair of teeth of said gear reckoned in said second displacement direction of said rack such that said second displacement force will cause said body to displace said rack in said first direction.
- 25 In a final aspect the present invention relates to an infusion pump system, comprising:
  - at least one infusion pump unit, comprising:
    - 30 a housing of a size allowing said infusion pump unit to be carried by a user as a portable infusion pump unit, said housing defining an exterior surface,
      - a fluid inlet provided accessibly at said exterior surface for establishing fluid communication from an external infusion bag to said fluid inlet,
      - a fluid outlet provided accessibly at said exterior surface for establishing fluid  
35 communication to an infusion site,



a controllable pumping system included within said housing and having an inlet and an outlet, said inlet being connected to said fluid inlet and said outlet being connected to said fluid outlet for allowing transfer of fluid from said fluid inlet to said fluid outlet through activating said controllable pumping system,

5 an electronic control means received within said housing for controlling the operation of said controllable pumping system, said electronic control means including at least two preset pumping programs for allowing said controllable pumping system to be controlled in at least two alternative infusion pumping operations, and

10 a power supply unit housed within said housing for supplying power to said controllable pumping system and to said electronic control means and connectible through exterior terminals provided at said exterior surface of said housing to external electric energy supply means,

a stationary receptor system including:

15

at least one receptor means for receiving and fixating one of said infusion pump unit therein so as to maintain said infusion pump unit in a stationary mode and exposing said fluid inlet and fluid outlet of said infusion pump unit for allowing access thereto and having first terminals connectible to said exterior terminals for supplying 20 said electric energy to said power supply unit of said at least one infusion pump unit and further having second terminals connectible to third terminals of a second receptor means for supplying power to said second receptor means,

25 a mains supply unit for receiving electric energy from the mains supply and having second terminals connectible to said third terminals for supplying said electric energy to said receptor means and thereby to said power supply unit of said at least one infusion pump unit, said mains supply unit constituting said external electric supply means, and

fastening means for fastening said receptor means adjacent one another and for fastening said mains supply unit adjacent one of said receptor means.

30

In the currently preferred embodiment, said system further comprises a carrier frame for carrying one infusion pump unit and provided with receiving means for receiving said infusion pump unit and preferably with releasable holding means for holding a container of infusion fluid communicating with said fluid inlet of said infusion pump unit, 35 said receptor means and said carrier frame having cooperating connection means for

allowing said frame to be connected to said receptor means such that said external terminals are connected to said first terminals.

Hereby a flexible system is obtained where an optional number of receptor means may  
5 be arranged adjacent one another and where great flexibility is achieved as to the transport of an infusion pump unit with the corresponding patient.

In the following the invention will be explained more in detail in connection with various embodiments thereof shown, solely by way of example, in the accompanying drawings  
10 in which

Fig. 1 is a perspective and schematic view of a first embodiment of a portable infusion pump unit according to the present invention,

15 Fig. 2 is an elevational and partly sectional view of the first embodiment of the portable infusion pump unit illustrated in fig. 1,

Fig. 3 is a schematic view of the interior of the first embodiment of the portable infusion pump unit illustrated in figs 1 and 2, disclosing the flow path thereof,  
20

Fig. 4 is a schematic view illustrating a possible application of the first embodiment of the portable infusion pump unit illustrated in figs 1, 2 and 3,

Fig. 5 is a perspective and schematic view illustrating the application of the first  
25 embodiment of the portable infusion pump unit illustrated in figs 1-4 in a stationary charger and fixation system for providing a stationary infusion pump system,

Figs. 6 and 7 are schematic illustrations of a first embodiment of a pump actuator  
30 according to the invention in two different positions, namely with the activating pin fully retracted in Fig. 6, and with the activating pin fully extended in Fig. 7,

Figs. 8 and 9 are schematic illustrations of a second and third embodiment,  
35 respectively, of a pump actuator according to the invention,

Figs. 10-12 are schematic illustrations of three stages in the operation of a fourth embodiment of an actuator according to the invention,

Fig. 13 is a graph showing two curves of Contraction versus Force for shape memory alloy wires for different biasing systems for the actuators according to the invention,  
5 and

Fig. 14 is a graph showing the relationship between various forces in Newton and the distance of displacement of a piston pump plunger in mm by the actuator shown in  
10 Figs. 10-12.

Figs. 15 and 16 are schematic illustrations similar to Fig. 2 of a second embodiment of an infusion pump unit according to the invention illustrating the use of the shape memory alloy actuators of Figs 6-7 and Figs 10-12, respectively, as the pump  
15 actuators

Fig. 17 is a sequence of schematic illustrations showing various stages in the pumping cycle of a fluid pumping system according to the invention utilising SMA actuators,

Fig. 18 schematically illustrates two stages in the operation of an SMA actuator incorporated in the pumping system in Fig. 17,  
20

Fig. 19 is a schematic illustration of a first embodiment of a shape memory alloy actuator motor for use in an infusion pump according to the invention,  
25

Fig. 20 is a schematic illustration of a second embodiment of a shape memory alloy actuator motor for use in an infusion pump according to the invention,

Fig. 21 is a schematic, partly sectional view of an infusion device according to the invention particularly well suited for dispensing insulin to a diabetes patient,  
30

Fig. 22 is a schematic view of the actuator and dispensing syringe of the device in Fig. 21,

Fig. 23 is a schematic view of a second embodiment of an actuator and a dispensing syringe for incorporation in the device in Fig. 21  
35

Fig. 24 is a schematic view of a rack-type SMA actuator for incorporation in the device in Fig. 21,

Fig. 25 is a perspective and schematic view illustrating an alternative application of the first embodiment of the portable infusion pump unit illustrated in figs 1-4 in a stationary 5 charger and fixation system for providing a stationary infusion pump system, and

Fig. 26 is a perspective and schematic view of the components of the system in Fig. 25.

10

In the drawings, a first embodiment of a portable infusion pump unit or apparatus is disclosed designated the reference numeral 10 in its entirety. The apparatus 10 comprises a housing composed of two shell-like housing parts 12 and 14 constituting a front and rear housing part, respectively. The front and rear housing parts 12 and 14, 15 respectively, are easily disassembled allowing the user to obtain access to the interior of the apparatus for substituting an interior fluid passage component to be described in greater detail below with reference to fig. 3 constituting a disposable pre-sterilized component which is easily demounted after use and readily replaced prior to use. From the rear side of the housing part 14, a clip 16 allowing the apparatus 10 to be 20 fixed to a strap or a belt extends. It is to be realised that terms such as upper, lower, front, rear, etc., unless otherwise stated, in the present context define positions or orientations determined by the intentional application of the apparatus 10 as the apparatus is positioned in an upright and substantially vertical position, e.g. received in the belt of a user by means of the clip 16 or otherwise positioned exteriorly or non- 25 implantatedly relative to the user.

In the front housing part 12, a display 20 is provided, comprising two sets of two digits designated the reference numerals 22 and 24, respectively, for displaying digits representing the time lapsed or the time remaining for infusion operation expressed in 30 minutes and hours, respectively, or seconds and minutes, respectively, or alternatively for displaying digits representing the supply of infusion liquid as expressed in volume per time unit, e.g. ml per hour. The display 20 further includes a display area 26 for informing the user and/or a person operating the infusion pump apparatus 10 or nursing the user regarding the operational mode of the apparatus, such as standby or 35 running information. Furthermore, the display 20 includes a number of individual displays positioned above one another and above the standby/running display 26, one

of which is designated the reference numeral 28. These individual displays 28 are adapted to display information such as the operational mode, e.g. the information that the apparatus is in a program mode, information regarding whatever information is presented on the two-digit displays 22, 24, such as the time remaining for infusion  
5 operation, the total time of the infusion operation, whether or not the apparatus is running or is to be started, or any other relevant information to be presented to the user or operator. The display 20 further includes three individual alarm displays 30, 32 and 34 for informing the user of the presence of air in the infusion pump circuitry, pressure fault or failure or low battery, respectively. A further display 36 informs the  
10 user or operator of the program sequence presently used or programmed, which program sequence is represented by a digit displaced by a 1-digit display 38. A 3-digit display 40 of the display 20 represents information to the user or operator regarding the infusion supply measured in ml per hour or similar relevant measure or ratio.

15 Below the display 20, a keyboard 42 is provided including a set of keys, one of which is designated the reference numeral 44 for allowing the user/operator to control the portable infusion pump unit 10 to perform a specific operation or to program the apparatus by shifting between specific program sequences by increasing a specific digit displayed in a 1-, 2- or 3-digit display, such as the displays 22, 24, 38 and 40, by  
20 increasing or reducing the digit in question and by shifting a cursor route relative to the various individual displays of the display 20 for allowing the user/operator to modify the operational mode or shift between various preset programs of the apparatus.

At the one side wall of the housing, composed by the housing parts 12 and 14 of the  
25 unit or apparatus 10, two terminals 46 and 48 are provided for allowing the apparatus 10 to be connected to an electronic charger for supplying electric power to an internal rechargeable battery pack or cell of the apparatus. The terminals 46 and 48 may alternatively or additionally serve as input/output terminals for establishing communication between the apparatus 10 and an external apparatus or equipment  
30 such as an external data logging apparatus or surveillance apparatus or further alternatively for communicating with an external processing unit such as a personal computer or data logging apparatus. Still further, the apparatus 10 may be provided with a conventional input/output terminal such as a conventional RS 232 terminal for establishing communication between the apparatus 10 and an external computer such  
35 as the above-mentioned personal computer for processing data produced by the apparatus concerning the operational mode of the apparatus and also supplementary

- data produced by the apparatus or auxiliary equipment, e.g. data representing the temperature of the infusion liquid supplied by the apparatus 10 or data supplied by additional external measuring or surveillance equipment. In the top wall of the housing of the apparatus 10 two recesses are provided for receiving two tube connectors 50 and 52 constituting a fluid inlet and a fluid outlet, respectively, of the above-mentioned fluid passage component to be described in further detail below with reference to fig. 3. As is evident from fig. 2, a further fluid outlet 54 is provided in the bottom wall of the housing of the apparatus 10 opposite to the fluid outlet 52.
- 10 In fig. 2, the interior structure of the portable infusion pump unit or apparatus 10 is disclosed, illustrating the fluid inlet 50 and the fluid outlets 52 and 54. In fig. 2, the reference numerals 56 and 58 designate two printed circuit boards including the electronic circuitry of the apparatus and including the display, the rechargeable power pack or cell circuitry and the CPU-circuitry of the apparatus controlling the overall operation of the apparatus including the infusion operation. Alternatively, the electronic circuitry of the apparatus may be included in a single printed circuit board or, alternatively, three or more printed circuit boards. The internal re-chargeable battery pack or cell is designated the reference numeral 60.
- 20 In fig 2, the internal flow system of the portable infusion pump apparatus 10 is disclosed, constituting a disposable and replaceable fluid passage component as mentioned above and including an inlet tube 62 connected to the fluid inlet 50. Two capacitive detectors 64 and 66 are mounted on the inlet tube 62 and communicate with the electronic circuitry of the apparatus housed on the printed circuit board 56 and 58 for detecting presence of air bubbles, if any, in the infusion liquid input to the fluid inlet 50. At its output end, the inlet tube 62 communicates with a first check valve 68 which constitutes an inlet to a pump housing component 70, in which an internal fluid passage is provided, as will be described in greater details below with reference to fig. 3, which fluid passage terminates in an output or second check valve 72 from which two branched-off outlet tubes 74 and 76 communicate with the fluid outlets 54 and 52, respectively. For transferring the infusion liquid or any other liquid input to the portable infusion pump unit 10 through the fluid inlet 50 to an application site through one of the fluid outlets 52 and 54, a piston type pump actuator 78 is provided. The internal flow system of the portable infusion pump comprising the fluid inlet 50, the inlet tube 52, the capacitive detectors 64 and 66 belonging to the inlet tube 62, the first check valve 68, the pump housing component 70, the output check valve 72, the outlet tubes 74 and 76, and the piston type pump actuator 78, is disclosed in greater detail below with reference to fig. 3.
- 30  
35

76, and the outlets 52 and 54 constitute an integral disposable and replaceable fluid passage component to be described in greater detail below with reference to fig. 3.

In fig. 3, the interior of the check valves and also the pump housing component 70 is disclosed in greater detail. The first check valve 58 basically comprises a central circular cylindrical housing component 80 from which a frusto-conical top part 81 extends upwardly communicating with the inlet tube 62 and arresting an inlet filter element 82 at the transition between the frusto-conical top part 81 and the cylindrical housing component 80. The cylindrical housing component 80 comprises a central annular oral component 84 which is sealed off in the initial or non-active position by a downwardly deflectable sealing membrane 86. Provided the pressure below the sealing membrane 86 is lower than the pressure above the membrane 86, the membrane 86 is forced downwardly allowing liquid to pass through the central aperture of the central annular component 84 and further through apertures 87 provided offset relatively to the centre of the sealing membrane 86.

The first check valve 68 communicates with an inlet passage 88 of the pumping house component 70 terminating in an inner chamber defined within an upwardly protruding annular top housing component 90 in which a reciprocating plunger 94 of the piston pump actuator 78 is movable in the direction to and from an abutting pin 96 which separates the inlet passage 88 from an outlet passage 98. The interspace between the reciprocating plunger of the piston pump 78 and the inner surface of the annular top housing component 90 is sealed by means of a highly flexible sealing gasket 92.

The outlet passage 98 communicates with the above described second check valve 72 which is basically of a configuration similar to and functioning as a check valve similar to the above described first check valve 58, however differing from the above described first check valve in that the second check valve 72 does not include any filter element similar to the filter element 82. The second check valve 72 includes a downwardly protruding annular housing part 100, which is cast integral with the pumping house component 70, fulfilling, however, the same purpose as the above described annular housing part 80 of the first check valve. From the annular housing part 100, a downwardly protruding frusto-conical housing part 101 similar to the above described frusto-conical housing part 81 extends communicating with the outlet tube 74 and similarly the outlet tube 76 described above with reference to fig. 2. Within the annular housing part 100, a sealing membrane 102 similar to the above described

sealing member 86 is received, which includes apertures 103 similar to the apertures 87 described above. The sealing membrane 102 communicates with a conical bore 99 communicating with the outlet passage 98 for sealing off communication from the outlet passage 98, through the conical bore 99 to the outlet tube 74 provided the  
5 sealing membrane 102 rests against an abutting lower surface defining the lower boundary of the conical bore 99.

The pumping operation of the portable infusion pump unit 10 is established as follows. Initially, the first check valve 68 and the second check valve 72 are in their initial and  
10 sealing positions. It is also assumed that liquid is present within the inlet tube 62 within the inlet passage 88 and the outlet passage 98 and also within the outlet tube 74. The piston pump actuator 78 is activated through the supply of an electric signal such as an alternating electric signal or a pulsed signal causing the reciprocating plunger 94 to move upwardly or downwardly. The piston pump actuator 78 will be described in  
15 greater detail below with reference to figs. 6-12. The plunger 94 is pressed downwardly in relation to the orientation of the piston pump actuator 78 shown in fig. 3.

Assuming that the first movement of the reciprocating plunger 94 is in movement upwardly, a relative vacuum is created within the inlet passage 88 and the outlet  
20 passage 98 by the increase of the volume defined below the sealing gasket 92. Through the creation of the relative vacuum within the inlet passage 88, the first check valve 68 is operated as the downwardly deflectable sealing membrane 86 is caused to move downwardly allowing liquid to flow into the inlet channel 88 through the central aperture of the central annular component 84 as described above. At the same time,  
25 the relative vacuum within the outlet passage 98 creates a relative vacuum above the sealing membrane 102 which is biased so as to prevent free flow through the second check valve 72 urging or forcing the sealing membrane into sealing off and abutting engagement with a wall part circumferentially encircling and defining the conical bore 99, and consequently preventing liquid from being transferred from the outlet passage  
30 98 to the outlet tube 74. In summary, during the raising of the reciprocating plunger 94, the first check valve 68 is activated and caused to open whereas the second check valve 72 is blocked.

As the reciprocating plunger is moved downwardly, a relative increased pressure is  
35 created within the inlet passage 88 and the outlet passage 98 and the operations of the first and second check valves are shifted as the relative increased pressure within



the inlet passage 88 causes the first check valve 68 to block and seal off whereas the increased pressure within the outlet passage 98 causes the second check valve 72 to open allowing the fluid present within the outlet passage 98 to be forced out through the conical passage 99, through the apertures 103 of the sealing membrane 102 and  
5 further into the outlet tube 74. The rate of transfer and consequence the flow of liquid from the outlet tube 74 is controlled by the rate of operation of the piston pump actuator 78 as an increased frequency of reciprocating the reciprocating plunger 94 increases the velocity of flow of fluid or liquid from the inlet tube 62 to the outlet tube 74.

10

Above the second check valve 72, a bypass valve is provided, comprising a sealing membrane 104 which is acted upon by a central stem element 106 of a turnable knob 108 so as to force the sealing membrane 104 into sealing off and abutting engagement with a conical bore 105 provided above and in registration with the above  
15 described conical bore 99. Provided the conical bore 105 is sealed off by means of the sealing membrane 104, the bypass valve is not in operation. Provided the sealing membrane 104 is raised from its sealing off and abutting engagement with the conical bore 105 as the knob 108 is rotated for causing elevation of the actuator stem 106, communication from the outlet passage 98 is established through a bypass passage  
20 110, bypassing the communication from the outlet passage 98 through the conical passage 99 for allowing fluid to flow from the outlet passage 98 through the bypass passage 110 and further through the apertures 103 of the sealing membrane 102 which is consequently not functioning as the bypass valve is in operation.

25 The piston pump actuator 78, which may constitute a replaceable component of the portable infusion pump unit or apparatus 10, may provide a specific stroke and, consequently, a specific flow volume per stroke. Therefore, the actuator 78 is preferably provided with a switch cooperating with a switch of the electronic circuitry of the apparatus for informing the microprocessor of the electronic circuitry of the  
30 apparatus of the type of piston pump actuator included within the apparatus at present. The technique of providing information to the microprocessor concerning the type of piston pump included within the apparatus at present may be established by means of numerous techniques well-known in the art per se such as by means of code switches, optic capacitive or inductive readers, or simply by means of a feedback circuit  
35 monitoring the work rate of the piston pump actuator.

In fig. 3, an inlet tube 112 is shown establishing communication from the inlet tube 62 through the fluid inlet 50 not shown in fig. 3, however, shown in fig. 2 from an infusion bag 114 which may constitute an infusion bag including an infusion liquid simply constituting physiological liquid or additionally or alternatively a drug suspended in any appropriate liquid, or alternatively blood plasma. The outlet from the outlet tube 74 of the portable infusion pump unit 10 shown in fig. 4 is connected to an outlet tube 116 through the fluid outlet 54, not shown in fig. 3, however, shown in fig. 2, which external outlet tube 116 communicates with a cannular assembly 118 of a basically conventional structure.

10

The inlet tube 112 and the outlet tube 116 may constitute separate inlet and outlet tubes to be connected to the infusion pump unit 10 through the inlet and outlet 50 and 52 or, alternatively, 54, respectively. Alternatively, and preferably, the inlet tube 112 and the outlet tube 116 constitute integral components of the disposable and replaceable fluid passage component illustrated in fig. 3, which fluid passage component is cooperating with and activated by means of the piston pump actuator 78. Further alternatively, the infusion bag 114 may be configured and housed within a container component which is configured so as to allow the infusion bag 114 to be received and supported on top of the infusion pump unit or apparatus 10 as the above-mentioned receiver is simply connected to and supported by the housing of the portable infusion unit or apparatus 10.

20

The infusion of liquid from the infusion bag 104 is further illustrated in fig. 4, in which the portable infusion pump 10 is received and fixed relative to an individual 120 by means of a belt or strap 122 on which the infusion bag 114 is further fixated. In fig. 4, the external inlet tube 112, the external outlet tube 116 and the cannular assembly 118 are also illustrated.

25

In fig. 5, the above described first embodiment of the portable infusion pump unit or apparatus 10 is shown in duplicate received within a stationary receptor 140 in which a plurality of receptor compartments 142 are defined. Each of the receptor compartments 142 is provided with a set of charger terminals for establishing electrical conductive communication with the charger terminal 46 and 48 of the apparatus or unit 10 received within the receptor compartment 140 in question for charging the internal rechargeable battery pack or cell of the apparatus or unit through the supply of electric energy from a mains power supply unit of the receptor assembly 140 which mains

30

35

supply power supply unit receives electric power through a coiled mains supply wire 148 terminating in a mains plug 150 which is received in a mains AC outlet socket 152.

The receptor assembly 140 further includes a set of indicator lamps 144 and 146.  
5 Provided none of the indicator lamps 144 and 146 corresponding to a specific receptor compartment 142 are turned off, the indication informs the user or operator that no charging is taking place in the receptor compartment in question. Provided a portable infusion pump unit is received within a specific receptor compartment 142, one of the lamps 144 and 146 corresponding to the receptor compartment is turned off, one of  
10 which informs the user or operator that the portable infusion pump unit in question is to be recharged, or alternatively the other lamp is turned on informing the user or operator that the portable infusion pump unit in question is fully charged and ready for use. Alternative information display modes, such as flashing of lamps for informing malfunction in the rechargeable battery pack or cell of the portable infusion pump is of  
15 course also readily deduceable.

In connection with infusion pumps, particularly portable medicinal infusion pumps, it is important that the pumping action be carried out by a very compact actuator functioning as quietly as possible, with as low energy consumption as possible and  
20 with as small a waste heat production as possible.

The pump actuator 78 in Figs. 2 and 3 is, according to the invention, a shape memory alloy actuator which embodies all the above desirable characteristics. Several shape memory alloy actuators for use as a pump actuator in medicinal infusion pumps will be  
25 described in following, it being understood that these actuators are particularly useful as the pump actuator 78 in Figs. 2 and 3.

Referring now to Figs. 6 and 7, a pivotable body in the form of a circular disc 1'  
30 is arranged for pivoting around a central pivot 2' fixedly attached to a not shown frame of the actuator, and the disc 1' is provided with a peripheral extension 3' and a yoke-like peripheral extension 5'. A tension coil spring 6' is at one end thereof pivotably attached to a fastening pin 7' fixedly attached to said frame and is at the other end thereof pivotably attached to a fastening pin 8' fixedly attached to the peripheral  
35 extension 3'.

Two wires or filaments 9' and 10' of a shape memory alloy such as nickel titanium alloy or nitinol, for instance supplied by the company DYNALLOY, INC, of Costa Mesa, California, USA, under the trade name FLEXINOL, are attached at one end thereof to electrically conductive terminals 11' and 12', respectively, fixedly attached to said  
5 frame.

The other end of each of the wires 9' and 10 is attached to an electrically conductive terminal 13' fixedly attached to the periphery of the disc 1'. The wires 9' and 10' extend along the periphery of the disc 1' such that the wires 9' and 10' when tensioned extend  
10 along and are supported by said periphery. In the drawings the wires 9' and 10' are shown spaced from said periphery for the sake of clarity.

A sliding body 14' having two arms 15' and 16' is arranged for sliding movement between two stop pins 17' and 18' attached to the frame. A pin 19' attached to the  
15 sliding body 14' is received in the fork 5a' of the yoke-like extension 5' such that the pin 19' may slide and rotate freely in the fork when the disc 1' pivots from the position shown in Fig. 6 to the position shown in Fig. 7 thereby slidingly displacing the body 14' from abutment against stop pin 18' to abutment against stop pin 17' with the arm 15', constituting the activating pin of the actuator, fully extended.

20 A proximity sensor 20' is attached to the frame and connected to not shown electrical conductors for transmitting a signal from the sensor to a not shown receiver. The terminals 11' and 12' are likewise each connected to an electrical conductor, not shown, connected to a not shown power source for supplying electrical power to the  
25 wires 9' and 10' for resistance heating thereof, the terminal 13' being likewise connected to the not shown power source through a not shown electrical conductor for closing the resistance heating circuit.

In use, the wires 9' and 10' are intermittently heated to the transformation or transition  
30 temperature (from martensitic to austenitic state) of the shape memory alloy which temperature for nitinol is approximately 90 °C. Thereby the length of the wire is shortened. When the wire cools to below 90 °C the length thereof reverts to normal, i.e. the wire lengthens. The speed at which the shortening takes place, i.e. the contraction time, is directly related to the current input. i.e. the voltage applied over the  
35 terminals 11' or 12' and 13'.

In the position depicted in Fig. 6, the intermediate disc 1' is in its outermost counter clock-wise position with the arm 15' fully retracted and with the wire 9' cooled to below 90 °C and the wire 10' heated to above 90 °C by applying an electrical voltage between the terminal 12' and 13' whereby an electrical current will flow through the wire 10'. The disc 1' has therefore been rotated counter clock-wise to the position shown by the contraction force exerted by the wire 10'.

In the next step, the wire 10' is cooled to below 90 °C and thereby lengthens to the shape indicated by the dotted line 10a' in Fig. 6. The actuator is now ready to perform an activating extension of the arm 15' towards the left, the end of the arm 15' being intended to come into contact with a not shown plunger 94 and depress or activate same during the movement of the arm 15' to the extended leftwards position thereof as depicted in Fig. 7.

Thereafter or simultaneously, the wire 9' is heated to above 90 °C whereby it contracts and exerts a clock-wise force on the disc 1' pivoting it clock-wise around the pivot 2' past the balance position of the disc 1' and spring 6' in which the attachment pins 7' and 8' of the spring 6' are aligned with the pivot 2'.

When the disc 1' has rotated clock-wise past said balance point, the tension force exerted by the spring 7' will continue the clock-wise rotation of the disc 1' to the position shown in Fig. 7 with the arm 15' fully extended and the wire 9' slack though still above 90 °C. This is the actual activating movement of the actuator where the force applied to the sliding body 14' by the extension 5' increases because of the increasing lever of force or moment arm of the tension force exerted by the spring 6' on the intermediate disc 1' with respect to the pivot 2' or axis of rotation of the disc 1'.

For applications where the force necessary to perform the function of the actuator, such as depressing the pump plunger 94 in Fig. 3, increases during the activating stroke, said increase of the spring force moment arm as the disc 1' rotates is a very advantageous feature as will be explained more in detail in connection with Figs 13 and 14 in the following.

An increase of the activating force of the actuator during the activating stroke is also achieved or enhanced by decreasing the distance of the pin 19' from the pivot 2' or axis of rotation of the disc 1' during the activating stroke whereby the moment arm or

lever of force of the displacement force exerted on the pin 19' by the yoke-like extension 5' with respect to the pivot 2' is decreased and thereby the displacement force is increased during the activating stroke. This shortening of said distance can be seen from the situation in Fig. 6 at the beginning of the activation stroke to the  
5 situation in Fig. 7 at the end of the activation stroke.

Finally, the wire 10' is heated above 90 °C so that it contracts and pivots the disc 1' back to the position shown in Fig. 6 whereby the activating cycle is ready to be repeated.

10

The length of the wire 10' is larger than the length of the wire 9' because the contraction or shortening of the wire 10' must be large enough to pivot the disc 1' from the position shown in Fig. 7 past the balance point mentioned above while the shortening of the wire 9' only has to be enough to pivot the disc 1' from the position  
15 shown in Fig. 6 past said balance point.

Nitinol wires will typically contract about 3% – 6% when heated past the transition temperature. The uncontracted length of the wire 10' should be enough to ensure that the uncontracted wire is fully extended in the position shown in Fig. 7 and that the  
20 contracted wire 10' is fully extended when the disc 1' is at least slightly past said balance point in the counter-clockwise direction, i.e. the uncontracted length of wire 10' should be about 22-25 times the distance of travel of terminal 13' between the Fig. 7 position thereof and the balance point position thereof.

25 The necessary contraction force to be exerted by wires 9' and 10' are rather different because the contraction force of wire 9' only has to counteract the torque or moment of the spring force of spring 6' with the relatively small torque arm in Fig. 6 while the contraction force of wire 10' has to counteract the considerably larger torque of said spring force in Fig. 7. The contraction force of a nitinol wire is larger the larger the  
30 diameter or cross sectional area of the wire. The cross sectional area of wire 10' is thus considerably larger than the cross sectional area of wire 9' or there may be a number of wires 10' with the same cross sectional area.

The latter possibility is chosen if it is necessary that the cooling-off time for the wires  
35 10' is as short of possible so that the interval between the activating cycles may be as short as possible. Several small diameter wires with a certain total cross sectional area

will cool more rapidly than a single larger diameter wire with the same cross sectional area.

The signal emitted by the proximity sensor 20' each time the extension 3' is in the position shown in Fig 7 may be utilised for many different purposes such as for instance a mere monitoring of the correct function of the actuator or for controlling the timing of the heating of the wires 9' and 10' and thereby the timing of the activating stroke of the sliding body 14'. Naturally, the location of the proximity sensor or of any other type of sensor for sensing the position of the disc 1' may be varied according to the purpose thereof, and several such sensors may be provided in different locations for instance for achieving a more complex control of the timing of the activating effect of the actuator.

Referring now to Fig. 8, this embodiment differs from the embodiment of Figs. 6-7 in that a double activating effect may be achieved for each cycle of heating and cooling the shape memory wires 21' and 22' that in this case are of equal length and cross sectional area. The rotation of the disc 1' counter-clockwise and clockwise is limited by stop pins 23' and 24', respectively.

The activating member may be a sliding body similar to body 14' in Fig. 6-7 where both the arm 15' and the arm 16' perform an activating function, or the activating function may be a pull/push activation by for instance arm 15'.

The disc 1' may alternatively be provided with a central torsion shaft projecting at right angles to the plane of the disc 1' as a prolongation of the pivot 2' such that the torsion shaft functions as the activating member by for instance rotating a lever to and fro. Many different types of activating members connected to the disc 1' will be obvious to those skilled in the art.

In the position shown in Fig. 8, the disc 1' has just performed an activating rotation counter-clockwise under the influence of the counter-clockwise torque of the force of the spring 6' and is ready for the initiation of a rotation clockwise by heating the wire 21' so that the disc 1' is rotated against the counter-clockwise torque of the spring force until the balance point is passed. Then the activating rotation clock-wise is performed by the clock-wise torque of the spring force. Also in this embodiment the

moment arm of the activating force of the spring 6' increases during the activating stroke in both directions.

Referring now to Fig. 9, the terminal 13' of the embodiments of Figs 6-8 has been substituted by a combined terminal and abutment member 28' for abutting the stop pins 24' and 25'. Furthermore, another type of biasing means is utilized, namely a piston and cylinder mechanism comprising a pressurized cylinder 24' pivotably attached to pin 7', a piston 26' and a piston rod 27' pivotably attached to the disc 1' by means of a pin 27'.

10

The piston and cylinder mechanism 24'-25' functions like a compression spring and could in fact be substituted by a compression spring. In Fig. 9 the disc 1' is in the balance point position where the pin 7', the pin 27' and the pivot 2' are aligned such that the pressure exerted on the disc 1' by the piston rod 25' does not produce any torque on the disc 1'. In the situation shown in Fig. 9, the wire 22' is contracting and rotating the disc counter clock-wise past the balance point. As soon as the balance point has been passed, the torque from the piston rod 25' will cause the activating counter clock-wise rotation of the disc 1' until the member 28' abuts the stop pin 23' whereupon a clockwise rotation may be initiated in a manner very similar to that described above in relation to Fig. 8.

20

The tension spring 6' in Figs. 6-7 could also be substituted by a piston and cylinder mechanism or a compression spring in an arrangement similar to Fig. 9.

Referring now to Figs. 10-12 an activating body 30' is arranged linearly displaceable in the directions of arrows R1 and R2 under the influence of a shape memory alloy wire 31' and a two-armed lever 32'.

25

One end of the wire 31' is attached to the body 30' at 33' and the other end is attached to a fixed portion 37a' of a not shown frame of the actuator, the wire 31' extending around a pulley 34' pivotably arranged on a slide 35' displaceable in the directions of the arrows R1 and R2. A compression spring 36' is arranged between the body 30' and the slide 35' and extends through a passage through a fixed portion 37' of said frame.

30

35



The two-armed lever 32' is arranged pivotable around a pivot 38', one arm 39' of the lever abutting a pin 40' on the body 30' and the other arm 41' of the lever being attached at 42' to one end of a tension spring 43', the other end being attached to a fixed portion 44' of said frame such that displacement of the body 30' in the direction of  
5 arrow R1 tensions the spring 43' via rotation of the intermediate lever 32'.

A pawl or hook element 45' is arranged pivotable around a pivot 46' such that a hook or projection 47' of the hook element 45' may be received in a matching recess 48' in the body 30'. A shape memory alloy wire 49' is at one end attached to the hook  
10 element 45' and at the other end attached to a fixed portion 50' of said frame. A compression spring 51' is arranged between the fixed portion 50' and the hook element 45'

In use, the body 30' is moved to and fro in the direction of the arrows R1 and R2 to  
15 activate the plunger 94 during the activating stroke of the body in the direction R1.

In Fig. 10 the wire 31' is cooled to below the transformation temperature of the alloy (for instance by sandwiching the wire between two aluminum rails coated with PTFE) and is at its maximum length and is maintained taut by the biasing action of the  
20 compression spring 36'. The hook 47' is received in the recess 48' and holds the body 30' against the biasing force of the spring 43' transmitted to the pin 40' by means of the lever 32'. The wire 49' is also in its cool state and at its maximum length.

When the activating stroke is to be initiated, the wire 49' is heated to the  
25 transformation temperature and shortens or contracts, thereby pivoting the hook element 45' against the biasing force of the spring 51' such that the hook 47' is pulled out of the recess 48' to the release position shown in Fig. 11. The body 30' is thus released for displacement in direction R1 under the influence of the lever 32' pivoted by the spring 43'.

30 During the activating stroke of body 30' in direction R1 the lever or moment arm of the force exerted by the spring 43' relative to the pivot 38' or the axis of rotation of the lever 32' increases such that the displacement force exerted on the pin 40' by the arm 39' increases as the body 30' is displaced in the direction R1.

35

Likewise, during the activating stroke by the body 30' in direction R1, the lever or moment arm of the displacement force exerted by the arm 39' on the pin 40' relative to the pivot 38' decreases whereby said displacement force increases as the body 30' is displaced in the direction R1.

5

When the slide 35' abuts the fixed frame portion 37', the activating stroke in direction R1 will be stopped as shown in Fig. 11. In practice the activating stroke preferably is stopped by the resistance to the activating stroke of the body 30' by the plunger 94 being activated such that the stroke is stopped before the slide 35' abuts the fixed frame portion 37'.

10

So as to cock the actuator again, the wire 49' is cooled to allow the spring 51' to pivot the hook element 45' towards the holding position thereof while the wire 31' is heated until it shortens and thereby causes the slide 35' to abut the fixed frame portion 37' and the pulley 34' to rotate clock-wise while the body 30' is displaced in the direction R2 against the force of the spring 43' that thereby is lengthened while the lever 32' pivots counter clock-wise. When the body 30' has reached the position shown in Fig. 12, the hook 47' is pressed into the recess 48' and the wire 31' may then be cooled so that the situation in Fig. 10 is re-established ready to initiate a new activation cycle of the actuator.

15

20

During the tensioning of the spring 43', the force exerted by the wire 31' necessary for this tensioning is largest at the beginning of the displacement of the body 30' in the direction R2 because of the large moment arm of the force of the spring 43' and the small moment arm of the rotation force of the pin 40' on the arm 39', and the force exerted by the wire 31' decreases as the body 30' is displaced in the direction R2.. This is an advantageous development of the force in the wire 31' during the cocking of the actuator as will be explained more in detail in the following in connection with Figs. 13 and 14.

25

30

By adapting the actuator according to the invention such that the activating stroke is performed by a force exerted by a biasing means, a further advantage is obtained in that any blocking of the activating stroke of the activating body, for instance because the pump plunger 94 is blocked, will only entail that the activation stroke is stopped with no damage to the SMA wire. If the activating stroke were carried out under the

35

influence of a shortening of a shape memory alloy wire, said wire would probably be damaged or snapped if the activating stroke were blocked.

The extra length of the wire 31' obtained by means of the pulley 34' is advantageous  
5 for giving a longer activating stroke with a compact construction of the actuator.

The heating of the wires 31' and 49' is carried out in a manner similar to the heating of the wires 9' and 10' in Figs 6-7 by means of not shown electrically conductive connections of the ends thereof to the battery pack 60 of the infusion pump unit  
10 according to the invention .

Referring now to Fig. 13, the curve or line 80' indicates the relationship between the force exerted by an SMA wire on a body in one direction while the body is biased by a tension spring in the opposite direction as a function of the contraction or shortening  
15 thereof. The force increases proportionally with the contraction because of the proportional increase of the spring force of the spring when it is stretched by contraction of the wire.

The line or curve 81 is symbolic of the curves corresponding to the relationship  
20 between contraction and force exerted for the embodiments of Figs. 6-9 where the force in the wires 10', 22', 24' and 31', respectively is largest at the beginning of the contraction or shortening, and the contraction length of the wire is much larger because of the variation in the length of the moment arm or arms during the activating stroke as described above.

25

In this manner, a high coefficient of mechanical efficiency is obtained because the longer contraction distance for a given input of energy to heat the SMA wires gives an increased input of energy into the activating system.

30 The actual curves 81 will not be linear but will reflect the varying rate of change of the moment arm or moment arms during the activating stroke.

Referring now to Fig. 14 and Figs 10-12, an actuator as shown in Figs. 10-12 is applied to depress the plunger 94 of the infusion pump in Fig. 3 thereof with the body  
35 30'.

The plunger 94 and body 30' travel from 0.2mm to 3.4mm during the activating stroke of the body 30'. The force required to displace the plunger increases substantially proportionally from approx. 0.5 N to approx. 2N where the force increases steeply because the plunger has reached the end of its path.

5

The force exerted by the spring 43' on the body 30' and thus the plunger 94 develops as an increasing parable-like curve corresponding to the curve for the tension or force in the SMA wire 31' necessary to retract the body 30' against the leveraged force of the spring 43'.

10

It is clear that the curves show that the actuator according to the invention can produce an increasing force as the displacement increases which is very advantageous in applications such as pumping with piston pumps where the force required increases with the distance traveled by the plunger.

15

Referring now to Figs. 15 and 16, the infusion pump unit 10 is very similar to the infusion pump unit 10 of Fig. 2, the sole difference being the location of the print cards 56 and 58. The actuators of Figs 6-7 and 10-12 are utilized as the pump actuator 78 in Fig 15 and Fig. 16, respectively. The SMA wires are supplied with electrical current for heating by the battery pack 60

20

The SMA actuators of Figs. 6-7 and 10-12 are particularly well-suited for depressing the pump membrane 92 (see Fig. 3) as the force needed for this operation increases as the membrane is depressed and the fluid is pressed out into the conduit 98. Furthermore, the operation of the SMA actuators is very quiet and the energy consumption is low while the space requirements are limited and the weight low.

25

As an example the SMA wire 31' of the SMA pump actuator of Fig. 16 is supplied with 4 amperes during 4 milliseconds for each pump depression cycle, and the maximum number of depression cycles for the infusion pump is normally of the order of magnitude of 10,000 cycles/hour.

30

Referring now to Figs 17 and 18, a fluid pumping system 60' comprises a flexible tube 61' extending through or between at least three clamping devices 62'-64' arranged adjacent one another. As illustrated in Fig. 18 the clamping devices each comprise a pivotable jaw 65' that is arranged to pivot towards a fixed jaw 66' to flatten the tube 61'

35

extending between the jaws 65' and 66' and to pivot away from the fixed jaw 66' to allow the tube 61 to return to its natural open shape.

Each of the pivotable jaws 65' is attached to one end of a biasing means such as a tension spring 67' the other end of which is attached to a fixed portion 68' of a not shown frame. Each of the pivotable jaws 65' is furthermore attached to one end of a shape memory alloy wire 69' the other end of which is attached to a fixed portion 70' of said frame. The jaws 65' are held in the closed position against jaw 66' by the springs 67' with the tube 61' flattened while shortening or contraction of the SMA wires 69' opens the clamping devices by pivoting the jaws 65' away from the fixed jaw 66'.

The pumping action is achieved by the sequence indicated from left to right in Fig. 17, all three clamping devices 62'-64' being clamped shut in the first stage from the left with all three wires 69' cooled to below the transition temperature and therefore slack.

15

In the second stage from the left devices 63' and 64' are opened by heating the corresponding wires 69' to above the transition temperature whereby fluid enters the thus opened portion of the tube 61' as indicated by arrow R5 .

20 In the third stage from the left device 64' is clamped shut by cooling the corresponding wire 69' such that the corresponding spring 67' can pull the corresponding jaw 65' against the tube 61' flattening it. Hereby a portion of fluid is trapped a space 71' in the tube 61'.

25 In the fourth stage from the left, the device 61' opens while the device 62' closes whereby the portion of fluid trapped in the space 71' is forced to flow in the direction of arrow R6 whereafter device 61' is closed and the first stage from the left has been re-established to begin a new pumping cycle.

30 If more than three clamping devices are utilized, the pumping effect will be enhanced.

This "finger" pump may substitute the pumping system in Figs 3, 15 and 16 as well as the check valves 68 and 72, and the pumping system (tube 61') may still be replaced without replacing the pump actuator by threading the tube 61' from between the jaws 65' and 66'. Thereby an extremely cheap replaceable pump is provided.

35

The pivoting of each of the jaws 65' of the clamping devices 62'-64' towards the fixed jaw 66' may be achieved by means of a body 15' of the actuator in Fig.6 or a body 30' of the actuator in Fig. 5.

- 5 The tube 61' may alternatively be flattened directly by said bodies 15' or 30' without the use of a clamping device. Hereby, a particularly simple pumping system is achieved where the replacement of the tube 61' is particularly simple.

10 Referring now to Fig. 19, a toothed wheel or gear 55" is rotatably arranged on a power output shaft 56" journalled in a not shown frame of the actuator motor. A body 57" having an edge portion 58" fitting between two neighbouring teeth 59" of the gear 55" is arranged in said frame displaceable between the position shown in full lines and the position shown in dotted lines.

15 A shape memory alloy wire 60" is at one end attached to the body 57" and at the other end to a fixed portion 61" of said frame. A coiled flat or wire spring 62" integral with or connected to an arm 63" is attached to said frame such that said arm 63" may pivot around one end thereof opposite the free end thereof. The arm 63" abuts a pin 64" on the body 57".

20

A pawl 65" is pivotably arranged on a pivot 66" and is biased by a tension spring 67" so as to constantly abut the rim of the gear 55".

25 In use, the gear 55" is turned clock-wise by the body 57" being displaced from the full line position to the dotted line position thereof by the force of the spring 62" acting through the intermediate arm 63" on the pin 64", whereby the gear advances the width of one tooth 59" and the pawl 65" moves from locking engagement between one pair of teeth 59" to a locking position between the next pair of teeth in the counter clock-wise direction.

30

When the gear is locked against rotating counter clock-wise by the pawl 65", the SMA wire 60" is heated and shortens whereby the body is displaced from the dotted line position to the full line position against the force of the intermediate arm 63" on the pin 64" thereby cocking the spring 62".

35

The lever or moment arm of the displacement force exerted by the intermediate arm in the clock-wise direction with respect to the pivoting point of the arm decreases as the body is displaced in the activating direction from the full line position to the dotted line position whereby the displacement force exerted by the intermediate arm 63" on the  
5 pin 64" increases.

Referring now to Fig. 20, a SMA actuator motor similar to the motor of Fig. 19 is shown, the spring 62" and intermediate arm 63" being substituted by a tension spring 68" fastened to the body 57" and to a fixed portion 69" of a not shown frame.  
10

The operation of the motor of Fig. 20 is very similar to the one in Fig. 19 except that the displacement force exerted on the body 57" by the spring 68" is exerted directly and declines substantially proportionally with the distance of displacement.

15 Referring now to Fig 21, an infusion pump 70" particularly well suited for infusing insulin to a diabetes patient comprises a housing 71" containing a display 72", on/off buttons 73", print cards 74" and a not shown battery pack. These elements will not be described further as they are well known to those skilled in the art and may vary greatly within the scope of the invention as defined by the appended patent claims.

20 A dispensing cartridge, ampoule or syringe 75" is replaceably arranged in the housing 71" and has an outlet nozzle 76" for communication with a not shown conduit means connected to the patient for delivering the fluid, preferably insulin, in the syringe 75" to said patient in a controlled manner either continuously or according to a pre-  
25 determined sequence.

A piston 77" is slidably arranged in the syringe 75". A threaded rod or spindle 78" abuts the piston 77" for displacing it towards the outlet nozzle 76" and meshes with a gear 79" meshing with a pinion 80" rotated by a shape memory alloy motor for  
30 displacing the spindle 78" towards the outlet nozzle 76".

Referring now to Fig. 22, the SMA motor of Fig. 20 is shown arranged and adapted for rotating the pinion 80" such that rotation of the gear 55" is geared down to a much slower rotation of the spindle 78" so as to dispense the liquid or paste in the syringe  
35 75" in very small amounts.

The SMA motor of Fig. 19 may very advantageously replace the motor of Fig. 19 in the configuration of Fig. 22 because of the reverse characteristic of the spring 62" compared to the characteristic of spring 68" as discussed in connection with Figs 13 and 14.

5

Referring now to Fig. 23, a different embodiment of the piston operation is illustrated, a double headed piston 81" being displaced by an arm 82" mounted on a carrier block 83" rotatably mounted on a spindle 84" such that rotation of the spindle 83" displaces the block 83", arm 82" and piston 81" towards the nozzle 76" for expelling liquid or  
10 paste in the syringe 75".

The spindle meshes with a gear 85" meshing with a pinion 86" attached to the shaft 56" of the SMA motor of Fig. 19, the spring 67" not being shown for the sake of clarity.

15 Referring now to Fig. 24, a rack 70"" is arranged displaceable in a not shown frame in the direction R4 and a body 71"" is arranged displaceable in the directions R3 and R4 as well as transversly thereto. A SMA wire 72"" is attached to the body 71"" and to a fixed portion 73"" of said frame. A coil spring 74"" attached to said frame and integral with or connected to an intermediate arm 75"" exerts a displacement force on a pin 76""  
20 of the body 71"" through the intermediate arm 75"" in a manner very similar to spring 62" in Fig. 19.

The rack 70"" advances the distance of the width of one tooth 78"" thereof in the direction R4 for every cycle of heating and cooling of the SMA wire 72"" in the same  
25 way as gear 55" in Fig. 19 is rotated by wire 60", spring 62", intermediate arm 63" and body 57" in Fig. 19.

The rack 70" may be used to push the piston 77" in Fig. 22 or piston 81" in Fig. 23 by means of front end 77"", to empty said cylinder of liquid or paste through an aperture in  
30 said cylinder.

Referring now to Figs 25 and 26, an optional number of infusion pump units 10 with corresponding inlet tube 112 and infusion bag 114 may be aggregated in a system of individual docking stations 100' arranged on a not shown standard hospital rack  
35 allowing horizontally adjustable location of the docking stations 100' that such two or more stations may be aligned abutting one another as shown in Fig. 25.



A power distribution and computer connection box 101' having connections 102' to a power source and a computer is also adapted for abutting a docking station 100' in aligned configuration therewith.

5

The distribution box 101' has a number of female contact plugs 103' for mating with corresponding, not shown, male contact plugs in a lateral wall of a docking station 100'. A diode 101a' indicates whether the distribution box is functioning or not. Each docking station has a number of female contact plugs 104' in the opposite lateral wall  
10 identical to contact plugs 103' for mating with said not shown male contact plugs of an adjacent docking station 100'.

The female and male contact plugs distribute electrical energy to the individual docking station and to the individual infusion pumps 10 docked in the docking stations  
15 100' via female contact plugs 105' mating with not shown corresponding male contact plugs in the bottom of each infusion pump 10.

Each infusion pump 10 is carried by a carrying frame 106' between arms 107' thereof and supported on a bottom platform 108' thereof. A hook 109' is provided on the  
20 carrying frame 106' for hooking into an aperture 110' of the infusion bag 114. The frame 106 furthermore has a top aperture 111' for receiving a hook on a bed or wheel chair when the pump 10 and bag 114 are to be removed from the docking station 100' for following a patient away from the fixed docking station array.

25 Each docking station 100' is provided with three diodes 112' for indicating status of the docking station and the pump as regards power supply, pumping status and fluid supply or other parameters desired monitored. Each docking station furthermore has two opposed grooves for slidingly receiving the lateral edges of a frame 106'

30 The system of Fig. 25 affords great flexibility as to number of infusion pumps per patient and as regards mode of transport together with the patient either on the frame 106' or removed therefrom.

35

## CLAIMS

1. An infusion pump system, comprising:

5

at least one infusion pump unit, comprising:

a housing of a size allowing said infusion pump unit to be carried by a user as a portable infusion pump unit, said housing defining an exterior surface,

10 a fluid inlet provided accessibly at said exterior surface for establishing fluid communication from an external infusion bag to said fluid inlet,

a fluid outlet provided accessibly at said exterior surface for establishing fluid communication to an infusion site,

15 a controllable pumping system included within said housing and having an inlet and an outlet, said inlet being connected to said fluid inlet and said outlet being connected to said fluid outlet for allowing transfer of fluid from said fluid inlet to said fluid outlet through activating said controllable pumping system,

a first check valve provided at said inlet of said controllable pumping system,

a second check valve provided at said outlet of said controllable pumping system,

20 an electronic control means received within said housing for controlling the operation of said controllable pumping system, said electronic control means including at least two preset pumping programs for allowing said controllable pumping system to be controlled in at least two alternative infusion pumping operations, and

25 a power supply unit housed within said housing for supplying power to said controllable pumping system and to said electronic control means and connectible through exterior terminals provided at said exterior surface of said housing to external electric energy supply means,

a stationary receptor system including:

30

a receptor means for receiving and fixating said at least one infusion pump unit therein so as to maintain said at least one infusion pump unit in a stationary mode and exposing said fluid inlet and fluid outlet of said at least one infusion pump unit for allowing access thereto, and

35 a mains supply unit for receiving electric energy from the mains supply and having terminals connectible to said exterior terminals for supplying said electric energy to

said power supply unit of said at least one infusion pump unit, said mains supply unit constituting said external electric supply means,

said pumping system including a pump and a shape memory alloy actuator for  
5 operating said pump.

2. An infusion pump unit comprising:

10 a housing of a size allowing said infusion pump unit to be carried by a user as a portable infusion pump unit, said housing defining an exterior surface,

a fluid inlet provided accessibly at said exterior surface for establishing fluid communication from an external infusion bag to said fluid inlet,

a fluid outlet provided accessibly at said exterior surface for establishing fluid communication to an infusion site,

15 a controllable pumping system included within said housing and having an inlet and an outlet, said inlet being connected to said fluid inlet and said outlet being connected to said fluid outlet for allowing transfer of fluid from said fluid inlet to said fluid outlet through activating said controllable pumping system,

a first check valve provided at said inlet of said controllable pumping system,

20 a second check valve provided at said outlet of said controllable pumping system,

an electronic control means received within said housing for controlling the operation of said controllable pumping system, said electronic control means including at least two preset pumping programs for allowing said controllable pumping system to be controlled in at least two alternative infusion pumping operations, and

25 a power supply unit housed within said housing for supplying power to said controllable pumping system and to said electronic control means and connectible through exterior terminals provided at said exterior surface of said housing to external electric energy supply means,

30 and to be used in connection with a stationary receptor system including:

a receptor means for receiving and fixating said at least one infusion pump unit therein so as to maintain said at least one infusion pump unit in a stationary mode and exposing said fluid inlet and fluid outlet of said at least one infusion pump unit for  
35 allowing access thereto, and

a mains supply unit for receiving electric energy from the mains supply and having terminals connectible to said exterior terminals for supplying said electric energy to said power supply unit of said at least one infusion pump unit, said mains supply unit constituting said external electric supply means,

5

said pumping system including a pump and a shape memory alloy actuator for operating said pump.

3. An infusion pump for infusing a liquid to a patient and comprising a pumping system  
10 including a pump and a shape memory alloy actuator for operating said pump.

4. An infusion pump system according to claim 1 or an infusion pump unit according to claim 2 or an infusion pump according to claim 3, wherein said shape memory  
15 actuator comprises:

- a body arranged displaceable between a first and a second position,
- releasable holding means adapted for holding said body in said first position,
- at least one first and at least one second wire made of a shape memory alloy such as nitinol, said first wire being at one end connected to said body such  
20 that shortening of the length of said first wire exerts a force on said body for moving said body from said second to said first position, and
- a biasing means, such as a tension spring, a compression spring, a straight or arcuate flat spring or a piston and cylinder mechanism, arranged and adapted for biasing said body for moving said body from said first to said second  
25 position,
- said second wire having one end connected to said holding means such that shortening of the length of said second wire releases said holding means for allowing said biasing means to move said body from said first position to said second position.

30

5. An infusion pump system or an infusion pump unit or an infusion pump according to claim 4, and further comprising means for intermittently directing an electric current through said first and/or second wires for heating said wires to at least the shape memory alloy transformation temperature.

35

6. An infusion pump system or an infusion pump unit or an infusion pump according to claim 4 or 5, wherein said holding means comprises a pivotable hook or pawl arranged pivotable between a holding position with said pawl received in a recess in said body and a release position with said pawl disengaged from said recess.

5

7. An infusion pump system or an infusion pump unit or an infusion pump according to claim 6, wherein said body is displaceably attached to a frame, one end of each of said first and second wires is attached to said frame and connected at the other end thereof with said body and said pawl, respectively, such that shortening of the length of said first wire exerts a displacing force on said body in a first direction and shortening of the length of said second wire exerts a pivoting force on said pawl in the direction from said holding position towards said release position, and said biasing means is attached to said frame and arranged for exerting a displacing force on said body in a second direction opposite said first direction.

15

8. An infusion pump system or an infusion pump unit or an infusion pump according to claim 7, wherein said biasing means is arranged and adapted to exert a rotation force on a rotatably arranged intermediate member such as a lever or a disc for rotating said intermediate member around an axis of rotation in a first direction of rotation from a first angular position to a second angular position, said intermediate member being connected to said body at a force transmission point such that rotation of said intermediate member in said first direction of rotation displaces said body in said second direction.

9. An infusion pump system or an infusion pump unit or an infusion pump according to claim 8, wherein said biasing means and said intermediate member are arranged and adapted such that the lever or moment arm of said rotation force with respect to said axis of rotation is larger when said intermediate member is in said second angular position than when said intermediate member is in said first angular position such that said lever or moment arm of said rotation force increases when said intermediate member rotates in said first direction of rotation, and/or said intermediate member and said body are arranged and adapted such that said rotation force is transmitted to said body as a displacement force applied at said force transmission point for moving said body from said first to said second position, and such that the lever or moment arm of said displacement force with respect to said axis of rotation is larger when said intermediate member is in said first angular position

than when said intermediate member is in said second angular position such that said lever or moment arm of said displacement force with respect to said axis of rotation decreases when said intermediate member rotates in said first direction of rotation.

- 5 10. An infusion pump system or an infusion pump unit or an infusion pump according to claim 9, wherein said intermediate member is a two armed lever having one arm connected to said biasing means, preferably a tension spring, and the other arm connected to said body.
- 10 11. An infusion pump system or an infusion pump unit or an infusion pump according to any of the claims 4-10, wherein said first wire extends from said end connected to said body around at least one pulley or roller and on to the opposite end of said first wire attached to a fixed point such that a given length of said first wire is accommodated in a limited space.
- 15 12. An infusion pump system or an infusion pump unit or an infusion pump according to any of the claims 6-11, wherein a pawl biasing means is arranged and adapted for urging said pivotable pawl from said release position towards said holding position.
- 20 13. An infusion pump system according to claim 1 or an infusion pump unit according to claim 2 or an infusion pump according to claim 3, wherein said shape memory actuator comprises:
- a body arranged displaceable between a first and a second position,
  - at least one first wire made of a shape memory alloy such as nitinol, said first  
25 wire being at one end connected to said body such that shortening of the length of said first wire exerts a force on said body for moving said body from said second to said first position,
  - a biasing means, such as a tension spring, a compression spring, a straight or arcuate flat spring or a piston and cylinder mechanism, and
  - 30 - a rotatably arranged intermediate member such as a lever or a disc connected to said body and to said biasing means,
- said biasing means being adapted for exerting a rotation force on said intermediate member for rotating said intermediate member around an axis of rotation in a first direction of rotation from a first angular position to a second angular position, said  
35 intermediate member being connected to said body such that rotation of said

intermediate member in said first direction of rotation displaces said body from said first position to said second position, and  
said biasing means and said intermediate member being arranged and adapted such that the lever or moment arm of said rotation force with respect to said axis of rotation is larger when said intermediate member is in said second angular position than when said intermediate member is in said first angular position such that said lever or moment arm of said rotation force increases when said intermediate member rotates in said first direction of rotation.

10 14. An infusion pump system according to claim 1 or an infusion pump unit according to claim 2 or an infusion pump according to claim 3, wherein said shape memory actuator comprises:

- a body arranged displaceable between a first and a second position,
- at least one first wire made of a shape memory alloy such as nitinol, said first wire being at one end connected to said body such that shortening of the length of said first wire exerts a force on said body for moving said body from said second to said first position,
- a biasing means, such as a tension spring, a compression spring, a straight or arcuate flat spring or a piston and cylinder mechanism, and
- 20 - a rotatably arranged intermediate member such as a lever or an arm connected to said body at a force transmission point on said body and connected to or integral with said biasing means,

said biasing means being adapted for exerting a rotation force on said intermediate member for rotating said intermediate member around an axis of rotation in a first direction of rotation from a first angular position to a second angular position, said intermediate member being connected to said body such that rotation of said intermediate member in said first direction of rotation displaces said body in from said first position to said second position, and  
said intermediate member and said body being arranged and adapted such that said rotation force is transmitted to said body as a displacement force applied at said force transmission point for moving said body from said first to said second position, and such that the lever or moment arm of said displacement force with respect to said axis of rotation is larger when said intermediate member is in said first angular position than when said intermediate member is in said second angular position such that said lever or moment arm of said displacement force with respect to said axis of rotation decreases when said intermediate member rotates in said first direction of rotation.

15. An infusion pump system or an infusion pump unit or an infusion pump according to claim 13 or 14, wherein said shape memory actuator further comprises:

- 5       - releasable holding means adapted for holding said body in said first position, and
- 10       - at least one second wire made of a shape memory alloy such as nitinol and having one end connected to said holding means such that shortening of the length of said second wire releases said holding means for allowing said biasing means to move said body from said first position to said second position.

16. An infusion pump system or an infusion pump unit or an infusion pump according to claim 15, wherein said holding means comprises a pivotable hook or pawl arranged pivotable between a holding position with said pawl received in a recess in said body and a release position with said pawl disengaged from said recess.

17. An infusion pump system or an infusion pump unit or an infusion pump according to claim 16, wherein said body is displaceably attached to a frame, one end of each of said first and second wires is attached to said frame and connected at the other end thereof with said body and said pawl, respectively, such that shortening of the length of said first wire exerts a displacing force on said body in a first direction and shortening of the length of said second wire exerts a pivoting force on said pawl in the direction from said holding position towards said release position, and said biasing means is attached to said frame and arranged for exerting a displacing force on said body in a second direction opposite said first direction.

18. An infusion pump system or an infusion pump unit or an infusion pump according to claim 13 or 14, and further comprising at least one second wire made of a shape memory alloy such as nitinol and having one end connected to said body such that shortening of the length of said first wire exerts a pivoting force on said body in one pivoting direction and shortening of the length of said second wire exerts a pivoting force on said body in the opposite pivoting direction, and said biasing means is attached to said body for exerting a pivoting force on said body in at least one of said pivoting directions.



19. An infusion pump system or an infusion pump unit or an infusion pump according to claim 18, wherein said biasing means is arranged for exerting a pivoting force on said body in both said pivoting directions with a balance point between said first and second position of said body wherein said biasing means does not exert a pivoting  
5 force on said body.

20. An infusion pump system or an infusion pump unit according to any of the claims 4-19, wherein said power supply unit is adapted for intermittently directing an electric current through said first and/or second wires for heating same to at least the shape  
10 memory alloy transformation temperature thereof.

21. An infusion pump system according to claim 1 or an infusion pump unit according to claim 2 or an infusion pump according to claim 3, wherein said shape memory actuator is incorporated in a shape memory alloy motor comprising:  
15

- said shape memory alloy actuator having:

- a body arranged displaceable between a first and a second position,
- at least one first wire made of a shape memory alloy such as nitinol, said first wire being at one end connected to said body such that shortening of the  
20 length of said first wire exerts a first displacement force on said body for moving said body from said second to said first position,
- a biasing means, such as a tension spring, a compression spring, a straight or arcuate flat spring or a piston and cylinder mechanism arranged and adapted for exerting a second displacement force on said body for moving said body  
25 from said first to said second position,

and

- a gear having a first and second rotation direction,  
said body having a portion adapted to fit between two adjacent teeth of said gear, and  
said body and said gear being adapted and arranged such that in said first position  
30 said portion is located between a pair of teeth of said gear and in said second position  
said portion is located between the adjacent pair of teeth of said gear reckoned in said  
second rotation direction of said gear such that said second displacement force will  
cause said body to rotate said gear in said first direction.

35 22. An infusion pump system or an infusion pump unit or an infusion pump according to claim 21 and further comprising a pawl member arranged displaceable between a

locking position between a pair of teeth of said gear for preventing rotation of said gear in said second direction and a release position.

23. An infusion pump system according to claim 1 or an infusion pump unit according to claim 2 or an infusion pump according to claim 3, wherein said shape memory actuator is incorporated in a shape memory alloy motor comprising:

- said shape memory alloy actuator, having
  - a body arranged displaceable between a first and a second position,
  - at least one first wire made of a shape memory alloy such as nitinol, said first wire being at one end connected to said body such that shortening of the length of said first wire exerts a first displacement force on said body for moving said body from said second to said first position,
  - a biasing means, such as a tension spring, a compression spring, a straight or arcuate flat spring or a piston and cylinder mechanism arranged and adapted for exerting a second displacement force on said body for moving said body from said first to said second position,

and

- a rack having a first and second displacement direction, said body having a portion adapted to fit between two adjacent teeth of said rack, and said body and said rack being adapted and arranged such that in said first position said portion is located between a pair of teeth of said rack and in said second position said portion is located between the adjacent pair of teeth of said gear reckoned in said second displacement direction of said rack such that said second displacement force will cause said body to displace said rack in said first direction.

25

24. An infusion pump system according to claim 1 or an infusion pump unit according to claim 2 or an infusion pump according to claim 3, wherein said shape memory actuator comprises::

- a body constituting or connected to an activating member such that said activating member is moved between a first and a second position when said body is moved between a third and a fourth position,
- releasable holding means for holding said body in said third position,
- at least one first and at least one second wire made of a shape memory alloy such as nitinol, said first wire being connected to said body such that

35

shortening of the length of said first wire exerts a force on said body for moving same from said fourth to said third position, and

- a biasing means, such as a tension or compression spring or a piston and cylinder mechanism, attached to said body for biasing said body for moving same from said third to said fourth position,
- said second wire being arranged such relative to said holding means that shortening of the length of said second wire or wires releases said holding means allowing said biasing means to move said body from said third position to said fourth position.

10

25. An infusion pump system or an infusion pump unit or an infusion pump according to claim 24, wherein said shape memory actuator comprises further comprises means for intermittently directing an electrical current through said first and second wires for heating same to at least the shape memory alloy transformation temperature.

15

26. An infusion pump system or an infusion pump unit or an infusion pump according to claim 24 or 25, wherein said holding means comprises a brake mechanism.

27. An infusion pump system or an infusion pump unit or an infusion pump according to any of the claims 24-26, wherein said holding means comprises a pawl mechanism.

20

28. An infusion pump system or an infusion pump unit or an infusion pump according to claim 24, wherein said body is pivotably attached to a frame, said first and second wires are attached at one end thereof to said frame and connected at the other end thereof with said body such that shortening of the length of said first wire exerts a pivoting force on said body in one pivoting direction and shortening of the length of said second wire exerts a pivoting force on said body in the opposite pivoting direction, and said biasing means is attached to said frame and arranged for exerting a pivoting force on said body in at least one of said pivoting directions.

30

29. An infusion pump system or an infusion pump unit or an infusion pump according to claim 28, wherein said biasing means is arranged for exerting a pivoting force on said body in both said pivoting directions with an intermediate balance point wherein said biasing means does not exert a pivoting force on said body.

35

30. An infusion pump system according to claim 1 or an infusion pump unit according to claim 2 or an infusion pump according to claim 3, wherein said shape memory actuator comprises:
- a frame with a body pivotably attached thereto,
  - 5 - at least one first wire and at least one second wire made of a shape memory alloy such as nitinol attached at one end thereof to said frame and connected at the other end thereof with said body such that shortening of the length of said first wire exerts a pivoting force on said body in one pivoting direction and shortening of the length of said second wire exerts a pivoting force on said  
10 body in the opposite pivoting direction, and
  - a biasing means attached to said frame and arranged for exerting a pivoting force on said body in at least one of said pivoting directions.
31. An infusion pump system or an infusion pump unit or an infusion pump according  
15 to claim 30, wherein said biasing means comprises a tension spring.
32. An infusion pump system or an infusion pump unit or an infusion pump according to claim 30 or 31, wherein said biasing means comprises a compression spring.
- 20 33. An infusion pump system or an infusion pump unit or an infusion pump according to any of the claims 30-32, wherein said biasing means comprises a piston and cylinder mechanism.
34. An infusion pump system according to claim 1 or an infusion pump unit  
25 according to claim 2 or an infusion pump according to claim 3, wherein said shape memory actuator comprises:
- a body constituting or connected to an activating member such that said activating member is moved between a first and a second position when said body is moved between a third and a fourth position,
  - 30 - holding means for holding said body in said third position,
  - at least one first wire and at least one second wire made of a shape memory alloy such as nitinol, said first wire being connected to said body such that shortening of the length of said first wire exerts a force on said body for moving same from said fourth to said third position, and

- a biasing means, such as a tension or compression spring or a piston and cylinder mechanism attached to said body for biasing said body for moving same from said third to said fourth position,
- said second wire being arranged such relative to said holding means that shortening of the length of said second wire releases said body from said holding means such that said biasing means may move said body from said third position to said fourth position.

35. An infusion pump system or an infusion pump unit or an infusion pump according to claim 34, wherein said body is pivotably attached to a frame, said first and second wires are attached at one end thereof to said frame and connected at the other end thereof with said body such that shortening of the length of said first wire exerts a pivoting force on said body in one pivoting direction and shortening of the length of said second wire exerts a pivoting force on said body in the opposite pivoting direction, and said biasing means is attached to said frame and arranged for exerting a pivoting force on said body in at least one of said pivoting directions.

36. An infusion pump system or an infusion pump unit or an infusion pump according to claim 35, wherein said biasing means is arranged for exerting a pivoting force on said body in both said pivoting directions with an intermediate balance point wherein said biasing means does not exert a pivoting force on said body.

37. A fluid pump, preferably for use in an infusion pump system according to claim 1 or in an infusion pump unit according to claim 2 or as an infusion pump according to claim 3, said fluid pump comprising:

- a flexible tube connected to a fluid inlet at one end and connected to a fluid exit at the opposite end,
- at least three flattening bodies for flattening said tube against an abutment element and arranged along the length of said tube, said bodies being arranged displaceable between a first position, wherein said body is pressed against said abutment element with said tube flattened between said body and said abutment element, and a second position spaced so far from said abutment element that said tube at least partly has regained an open configuration,
- at least one first wire for each flattening body and made of a shape memory alloy, said first wire being at one end connected to said body such that shortening of the

length of said first wire exerts a force on said body for moving said body from said first to said second position, and

a biasing means, such as a tension spring, a compression spring, a straight or arcuate flat spring or a piston and cylinder mechanism, for each of said flattening  
5 bodies and connected to said flattening body such that a biasing force is exerted on said flattening body in a direction from said second position to said first position.

38. An infusion pump for infusing a fluid or a paste in a patient, preferably a portable infusion pump and preferably for use in infusing insulin or a pain killer fluid in a patient,  
10 said infusion pump comprising:

- a housing,
- a cartridge, ampoule or syringe containing said fluid or paste and removably arranged in said housing and having an outlet aperture and a piston element slidably  
15 arranged inside said syringe such that said piston is displaceable towards said outlet aperture,

- a spindle connected to said piston element and arranged such that rotation of said spindle in a first rotational direction displaces said piston towards said outlet aperture
- a shape memory alloy actuator incorporated in a shape memory alloy motor  
20 comprising:

- said shape memory alloy actuator having:
  - a body arranged displaceable between a first and a second position,
  - at least one first wire made of a shape memory alloy such as nitinol, said first wire being at one end connected to said body such that shortening of the  
25 length of said first wire exerts a first displacement force on said body for moving said body from said second to said first position,
  - a biasing means, such as a tension spring, a compression spring, a straight or arcuate flat spring or a piston and cylinder mechanism arranged and adapted for exerting a second displacement force on said body for moving said body  
30 from said first to said second position,

and

- a gear having a first and second rotation direction,  
said body having a portion adapted to fit between two adjacent teeth of said gear, and  
said body and said gear being adapted and arranged such that in said first position  
35 said portion is located between a pair of teeth of said gear and in said second position said portion is located between the adjacent pair of teeth of said gear reckoned in said

second rotation direction of said gear such that said second displacement force will cause said body to rotate said gear in said first direction, and said gear being connected to said spindle, preferably via at least one further gear such that rotation of said gear in said first direction causes said spindle to rotate in said first rotational direction.

38. An infusion pump according to claim 37 and further comprising a pawl member arranged displaceable between a locking position between a pair of teeth of said gear for preventing rotation of said gear in said second direction and a release position.

10

39. An infusion pump for infusing a fluid or a paste in a patient, preferably a portable infusion pump and preferably for use in infusing insulin or a pain killer fluid in a patient, said infusion pump comprising:

15 - a housing,

- a cartridge, ampoule or syringe containing said fluid or paste and removably arranged in said housing and having an outlet aperture and a piston element slidably arranged inside said syringe such that said piston is displaceable towards said outlet aperture,

20 - said shape memory alloy actuator, having

- a body arranged displaceable between a first and a second position,  
- at least one first wire made of a shape memory alloy such as nitinol, said first wire being at one end connected to said body such that shortening of the length of said first wire exerts a first displacement force on said body for moving said body from said second to said first position,

25

- a biasing means, such as a tension spring, a compression spring, a straight or arcuate flat spring or a piston and cylinder mechanism arranged and adapted for exerting a second displacement force on said body for moving said body from said first to said second position,

30 and

- a rack having a first and second displacement direction and abutting said piston such that displacement of said rack in said second displacement direction displaces said piston towards said outlet aperture,

Said body having a portion adapted to fit between two adjacent teeth of said rack, and said body and said rack being adapted and arranged such that in said first position said portion is located between a pair of teeth of said rack and in said second position

35

said portion is located between the adjacent pair of teeth of said gear reckoned in said second displacement direction of said rack such that said second displacement force will cause said body to displace said rack in said first direction.

5 40. An infusion pump system, comprising:

at least one infusion pump unit, comprising:

10 a housing of a size allowing said infusion pump unit to be carried by a user as a portable infusion pump unit, said housing defining an exterior surface,

a fluid inlet provided accessibly at said exterior surface for establishing fluid communication from an external infusion bag to said fluid inlet,

a fluid outlet provided accessibly at said exterior surface for establishing fluid communication to an infusion site,

15 a controllable pumping system included within said housing and having an inlet and an outlet, said inlet being connected to said fluid inlet and said outlet being connected to said fluid outlet for allowing transfer of fluid from said fluid inlet to said fluid outlet through activating said controllable pumping system,

20 an electronic control means received within said housing for controlling the operation of said controllable pumping system, said electronic control means including at least two preset pumping programs for allowing said controllable pumping system to be controlled in at least two alternative infusion pumping operations, and

25 a power supply unit housed within said housing for supplying power to said controllable pumping system and to said electronic control means and connectible through exterior terminals provided at said exterior surface of said housing to external electric energy supply means,

a stationary receptor system including:

30 at least one receptor means for receiving and fixating one of said infusion pump unit therein so as to maintain said infusion pump unit in a stationary mode and exposing said fluid inlet and fluid outlet of said infusion pump unit for allowing access thereto and having first terminals connectible to said exterior terminals for supplying said electric energy to said power supply unit of said at least one infusion pump unit  
35 and further having second terminals connectible to third terminals of a second receptor means for supplying power to said second receptor means,



a mains supply unit for receiving electric energy from the mains supply and having second terminals connectible to said third terminals for supplying said electric energy to said receptor means and thereby to said power supply unit of said at least one infusion pump unit, said mains supply unit constituting said external electric supply  
5 means, and

fastening means for fastening said receptor means adjacent one another and for fastening said mains supply unit adjacent one of said receptor means.

41. A system according to claim 40 and further comprising a carrier frame for carrying  
10 one infusion pump unit and provided with receiving means for receiving said infusion pump unit and preferably with releasable holding means for holding a container of infusion fluid communicating with said fluid inlet of said infusion pump unit, said receptor means and said carrier frame having cooperating connection means for allowing said frame to be connected to said receptor means such that said external  
15 terminals are connected to said first terminals.

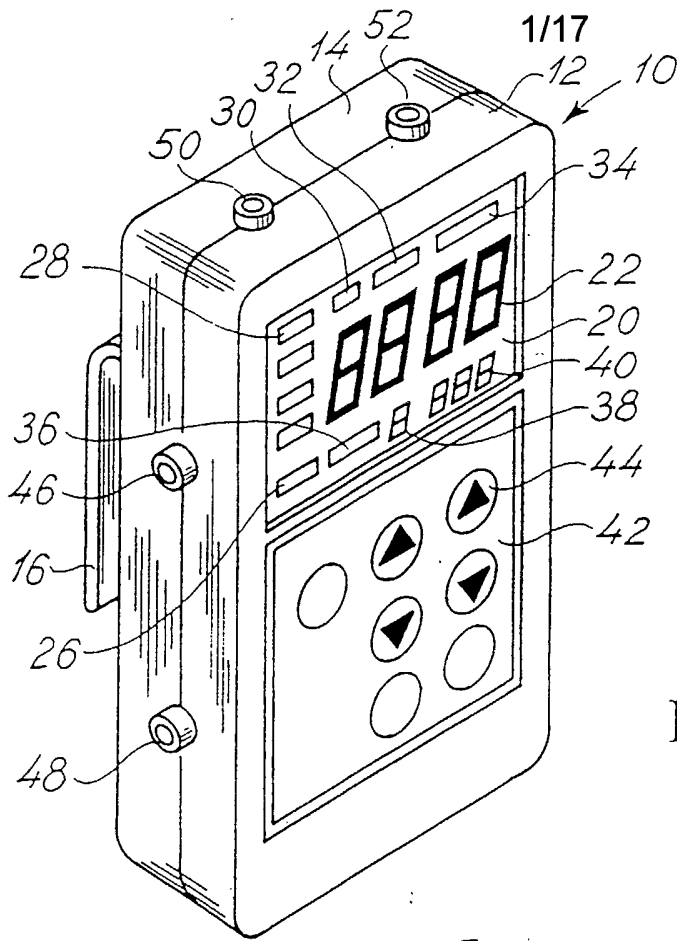

Fig. 1

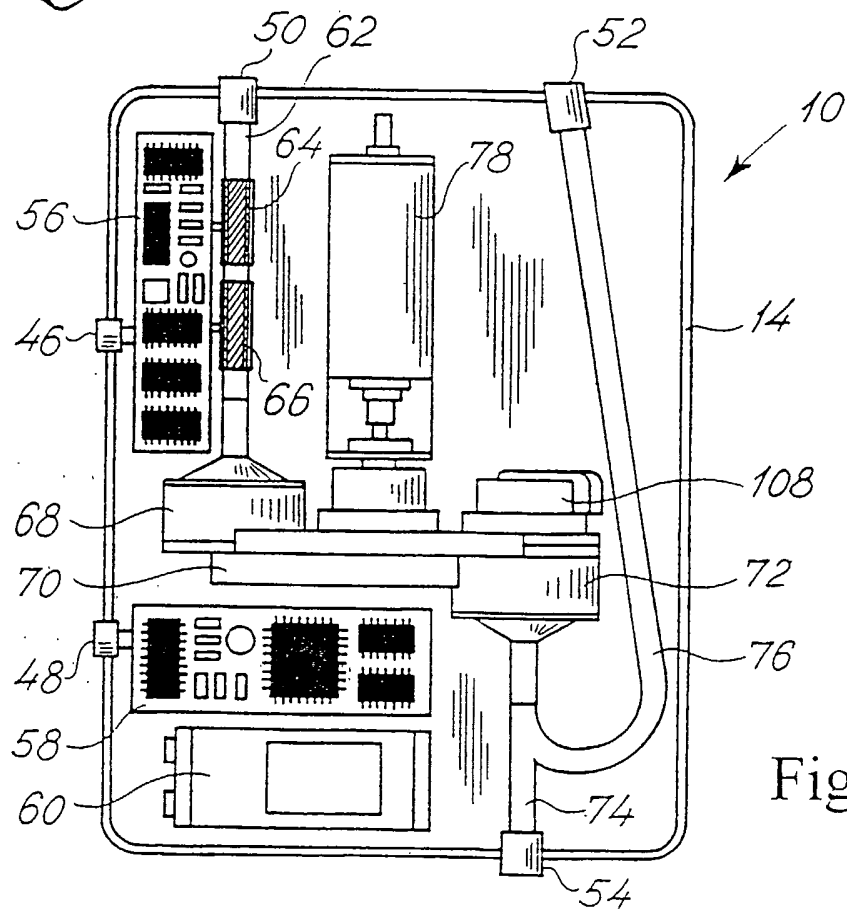

Fig. 2

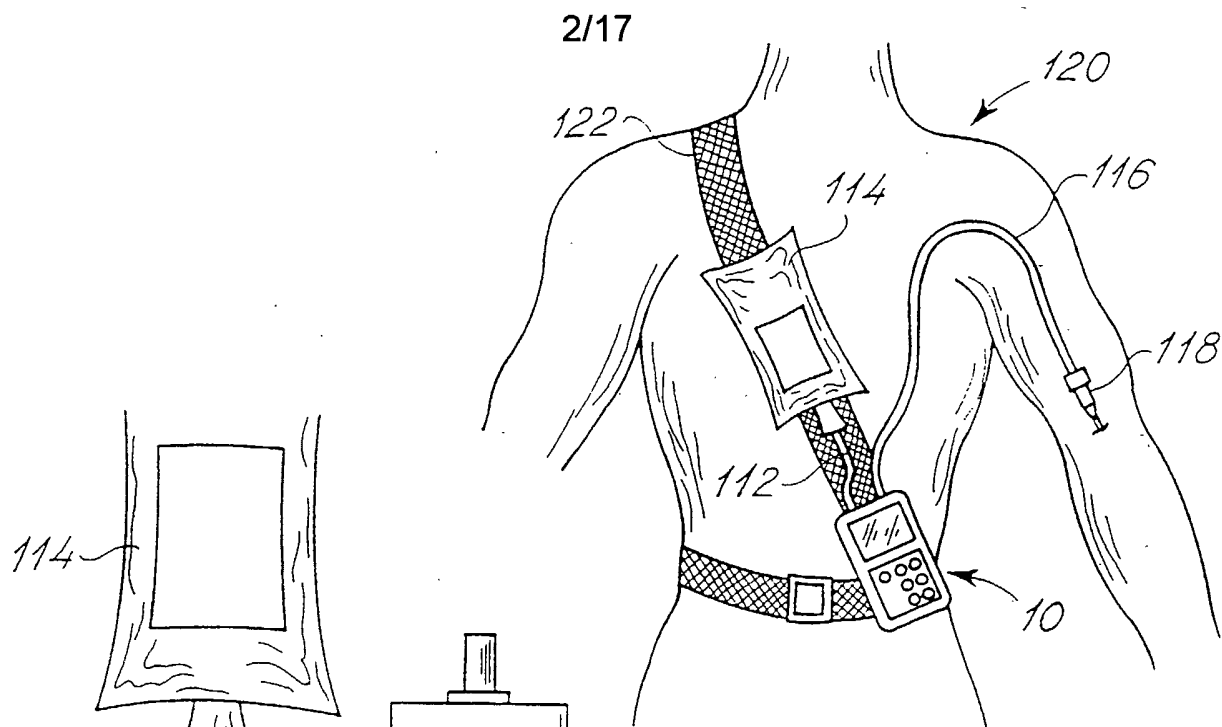

Fig. 4

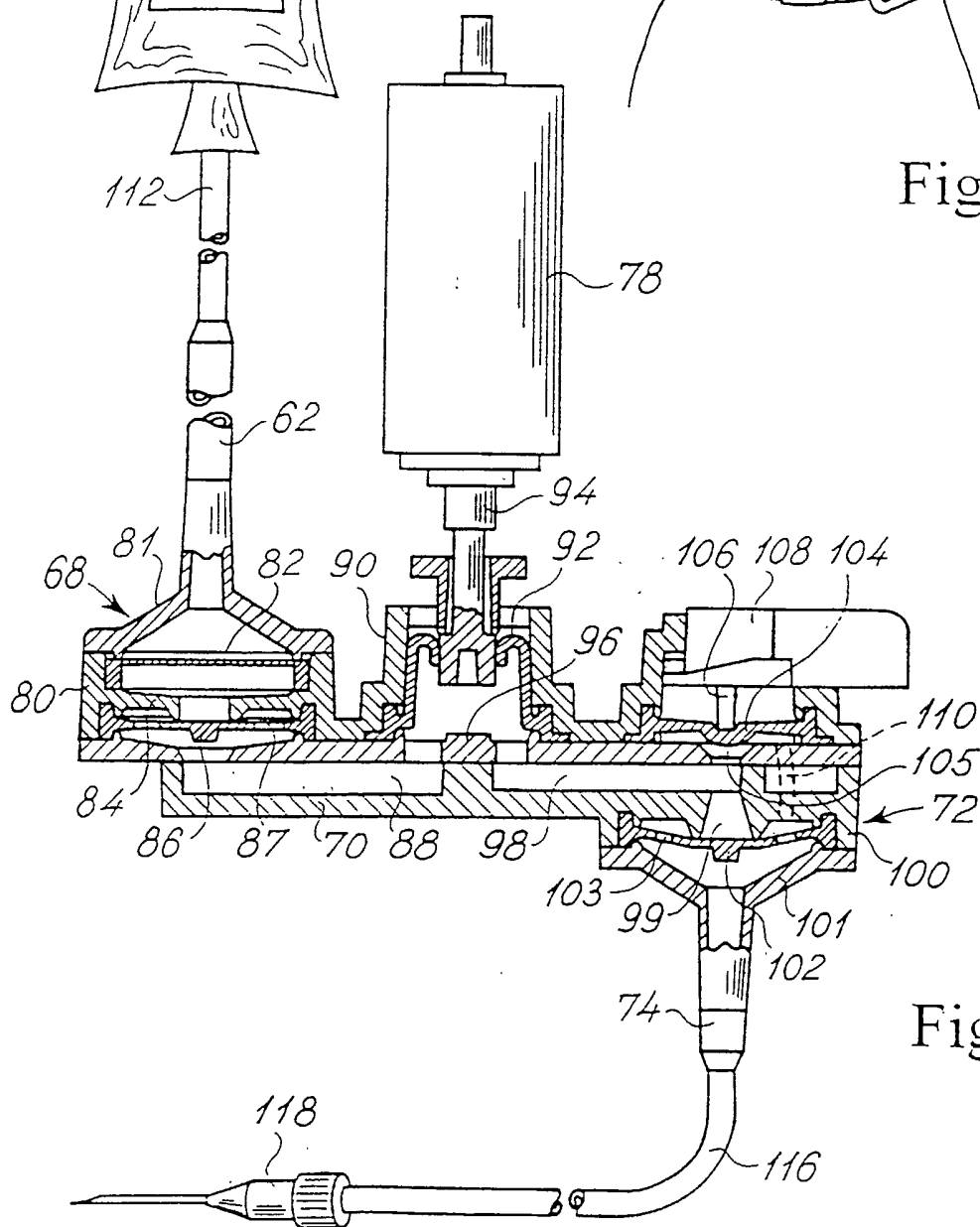

Fig. 3

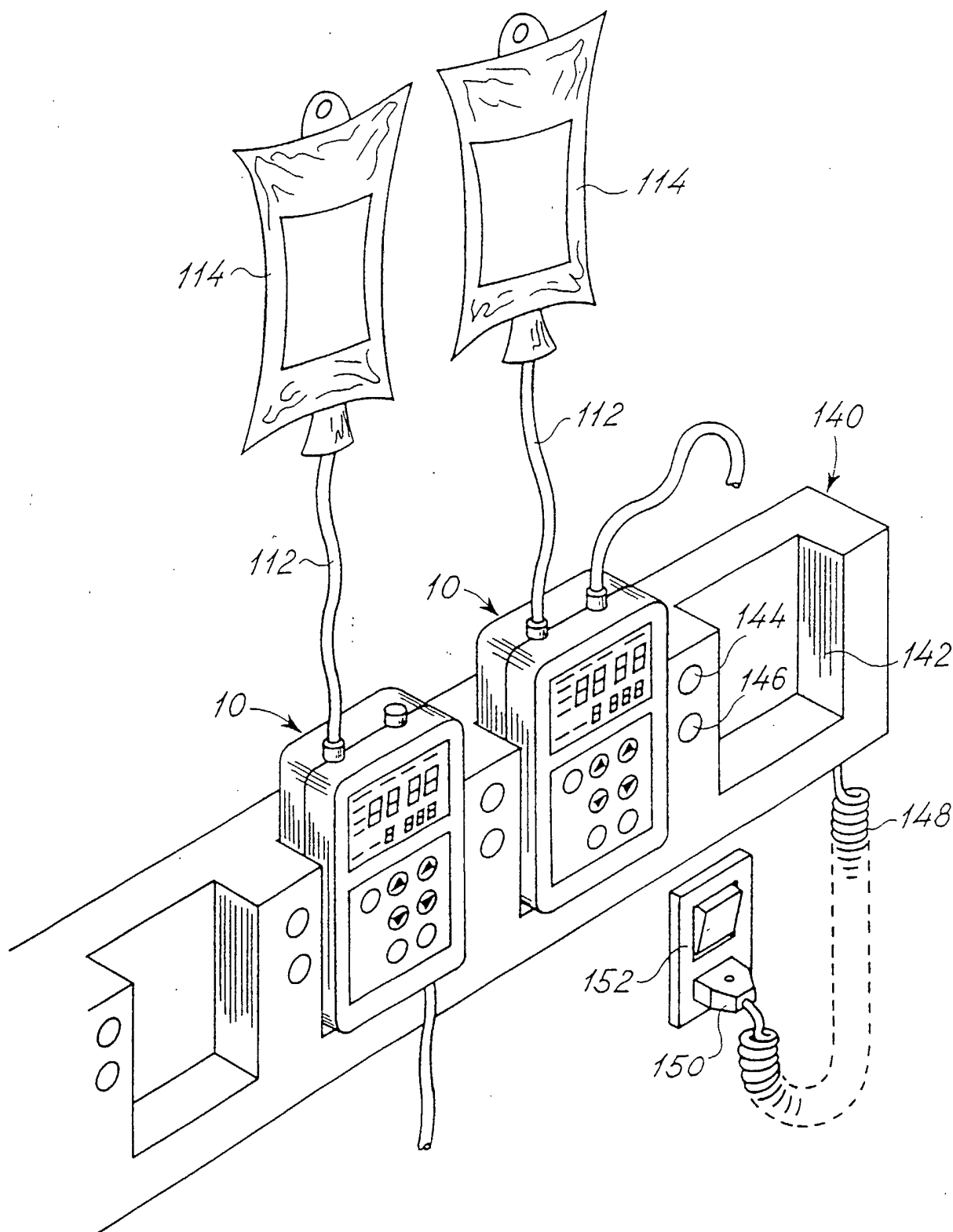

Fig. 5

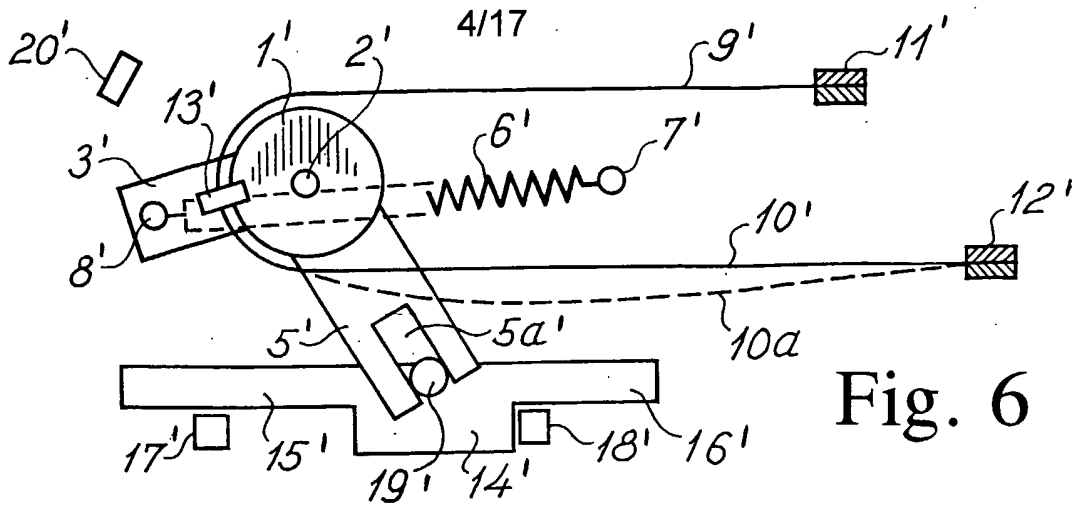

Fig. 6

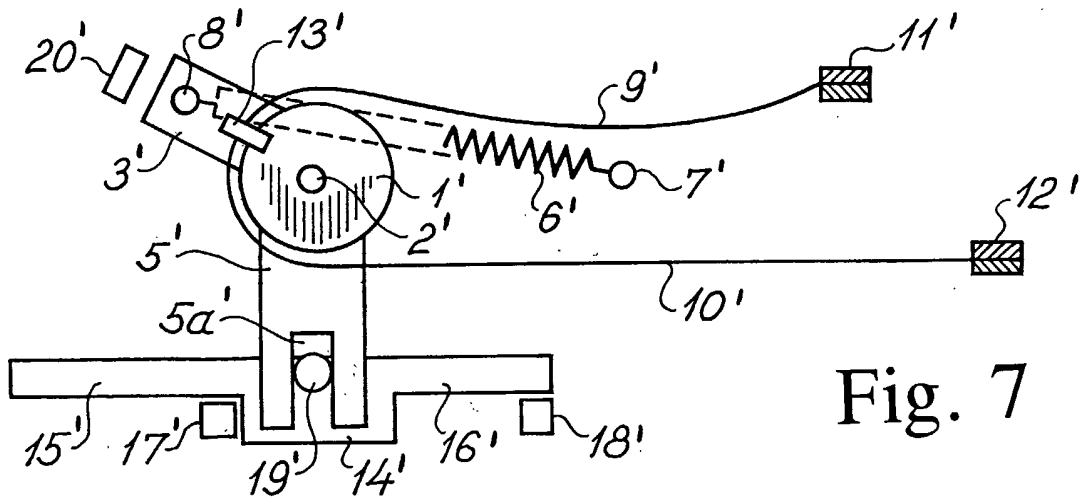

Fig. 7

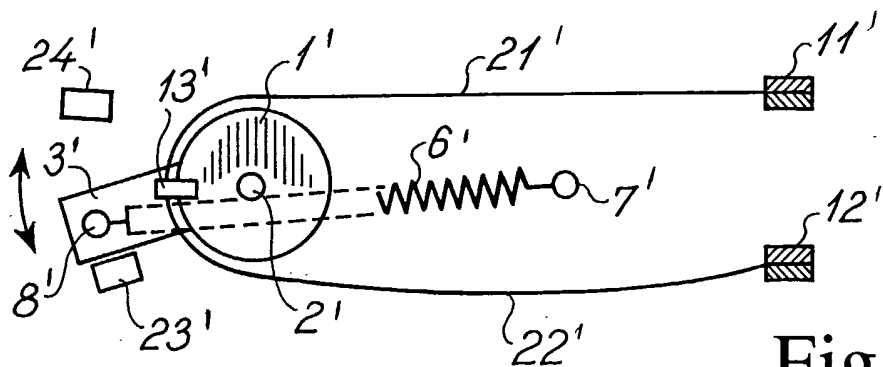

Fig. 8

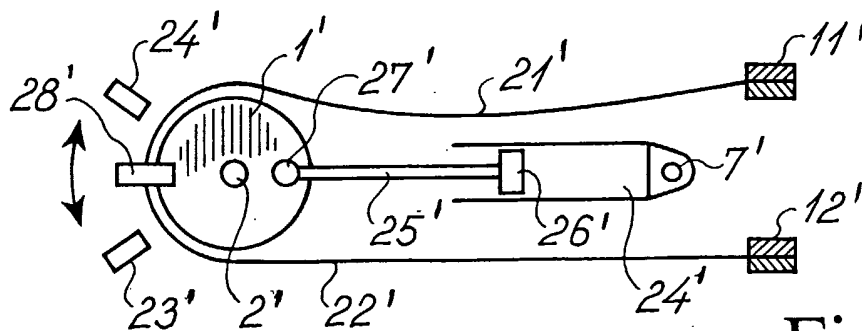
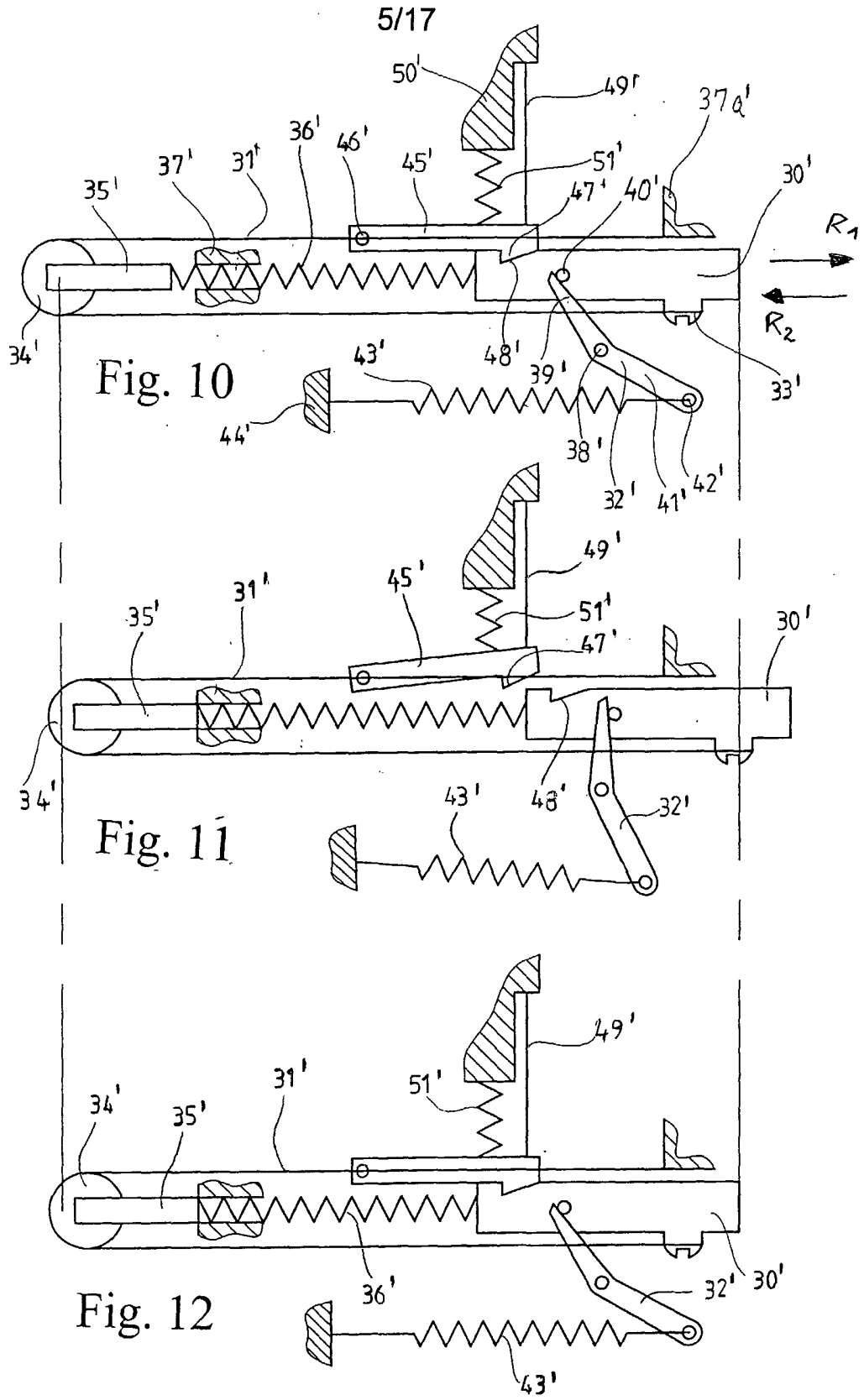
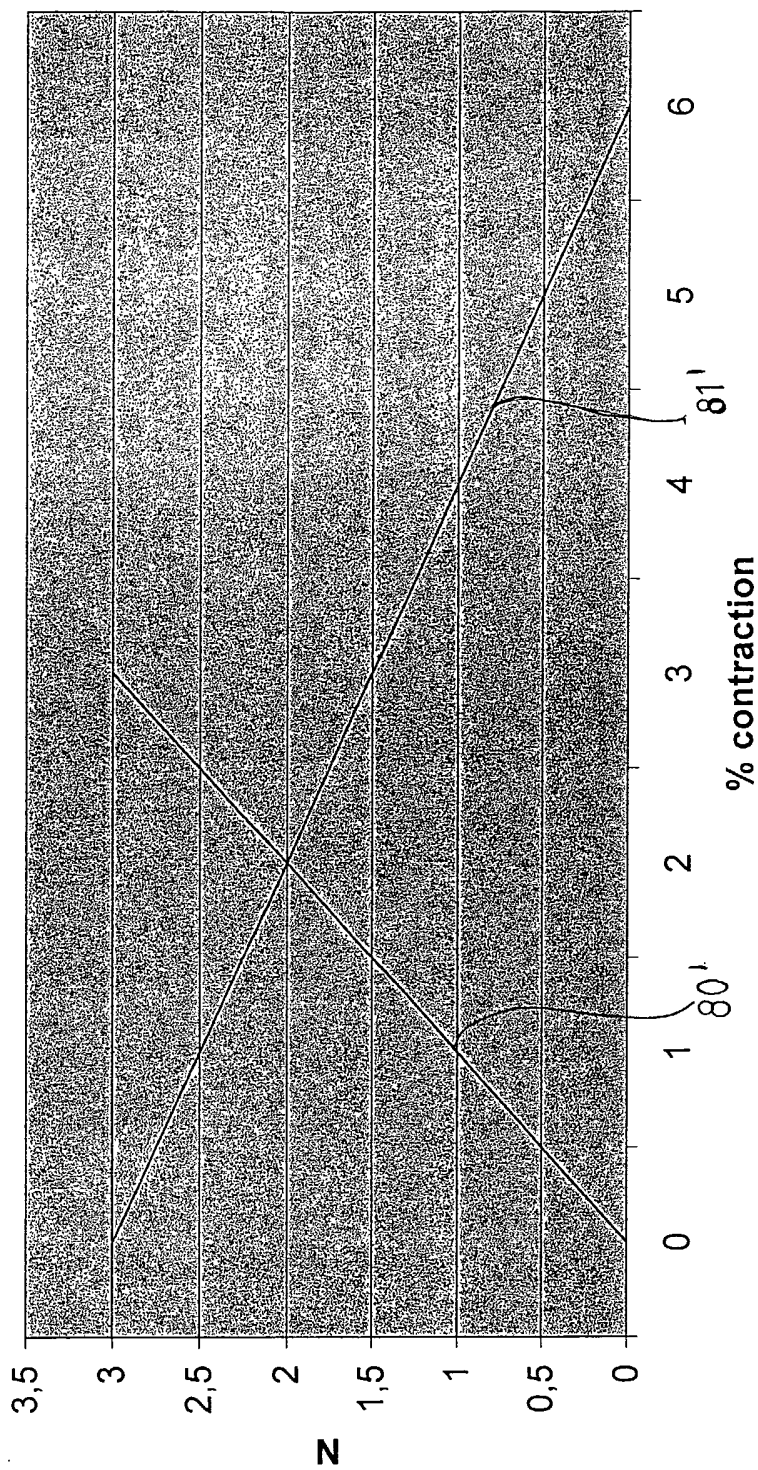

Fig. 9



Contraction vs force Fig. 13



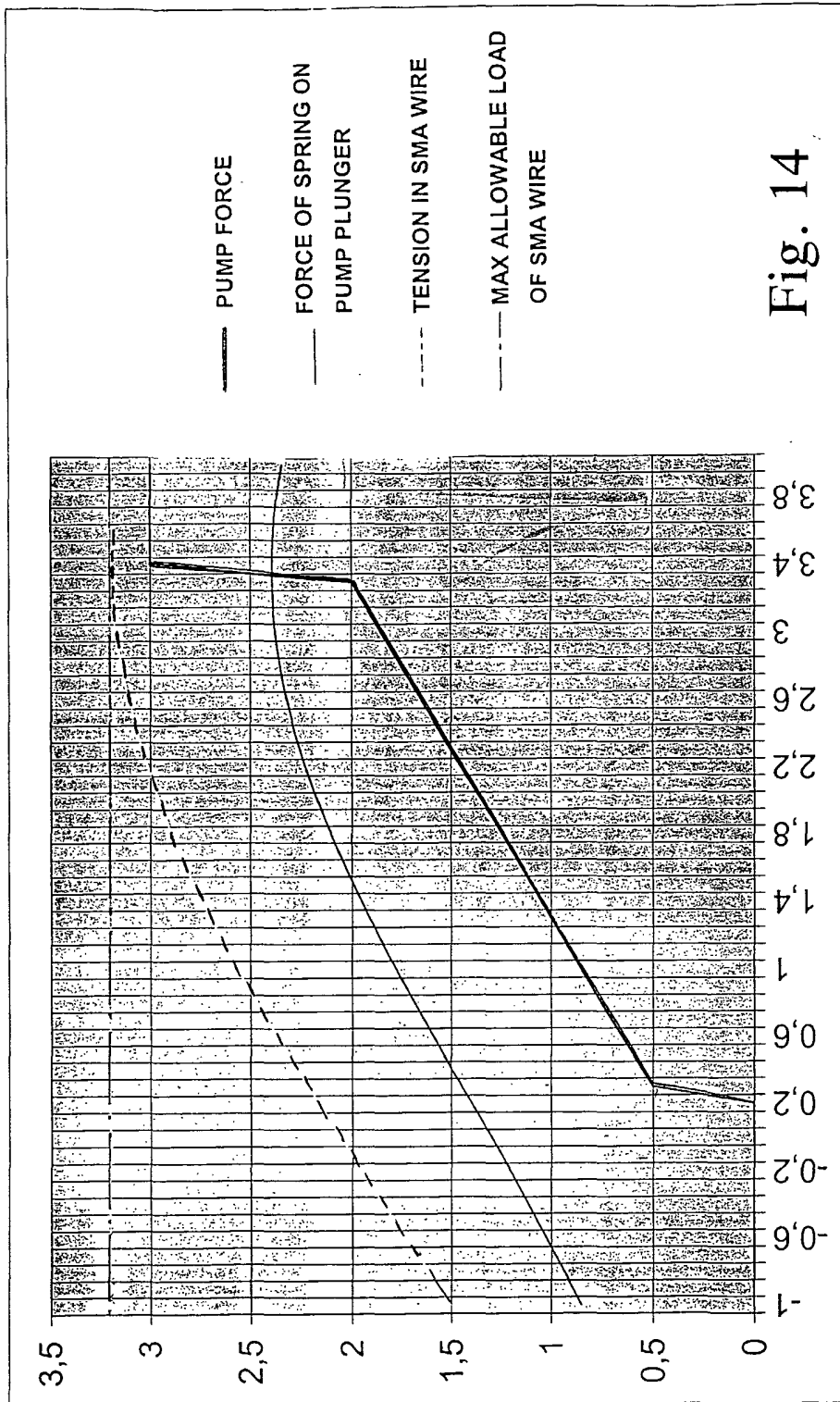

Fig. 14



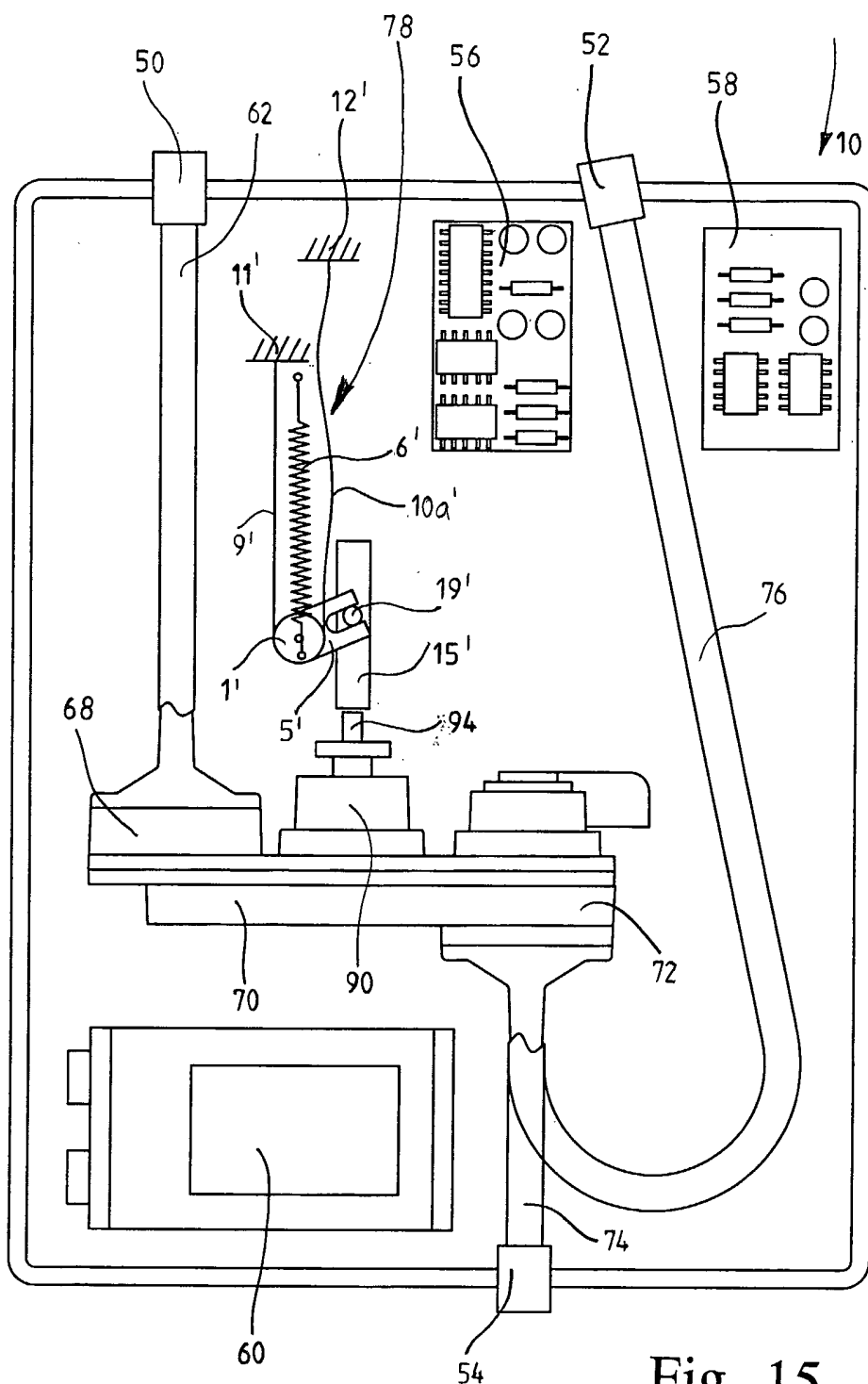

Fig. 15

9/17

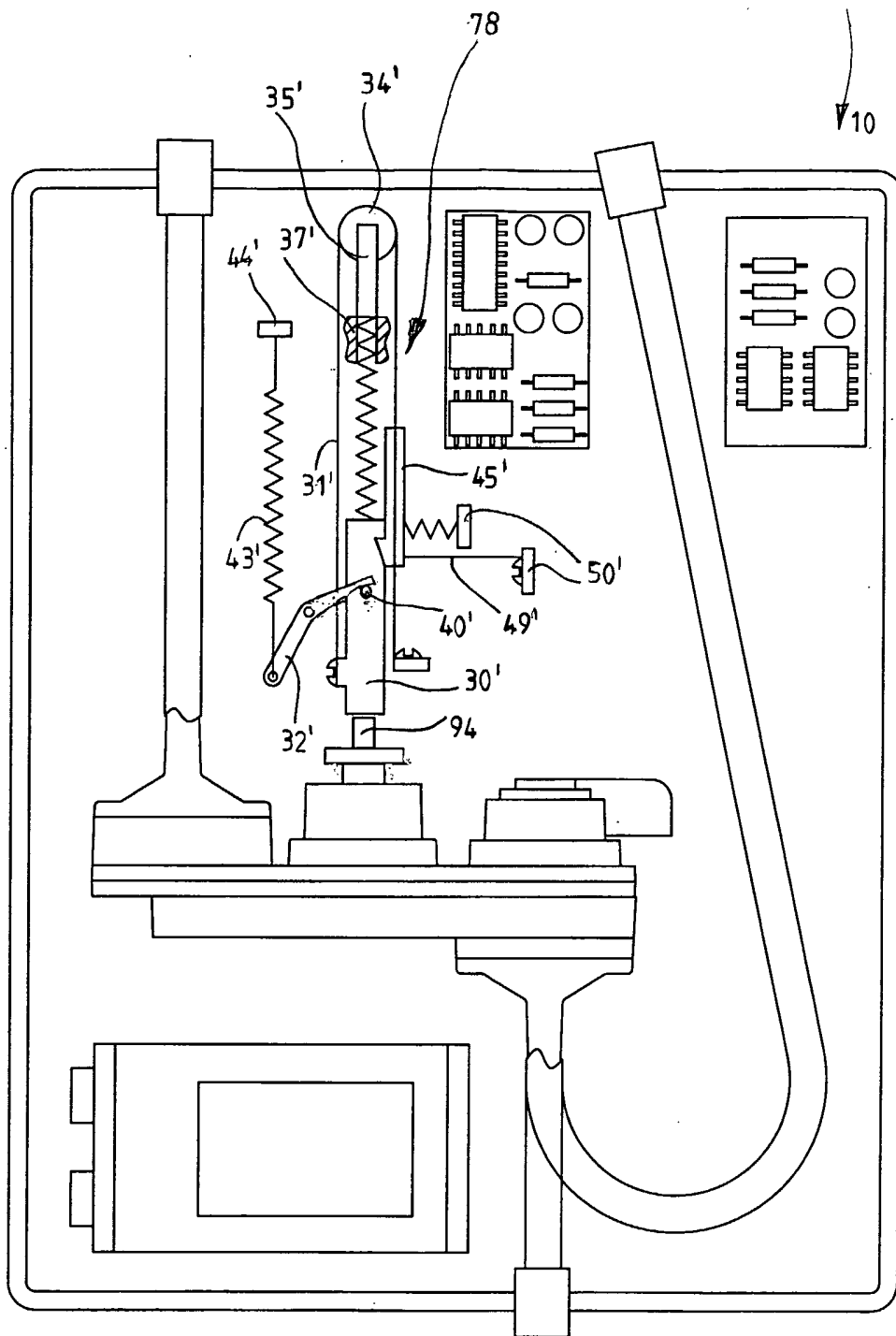

Fig. 16

10/17

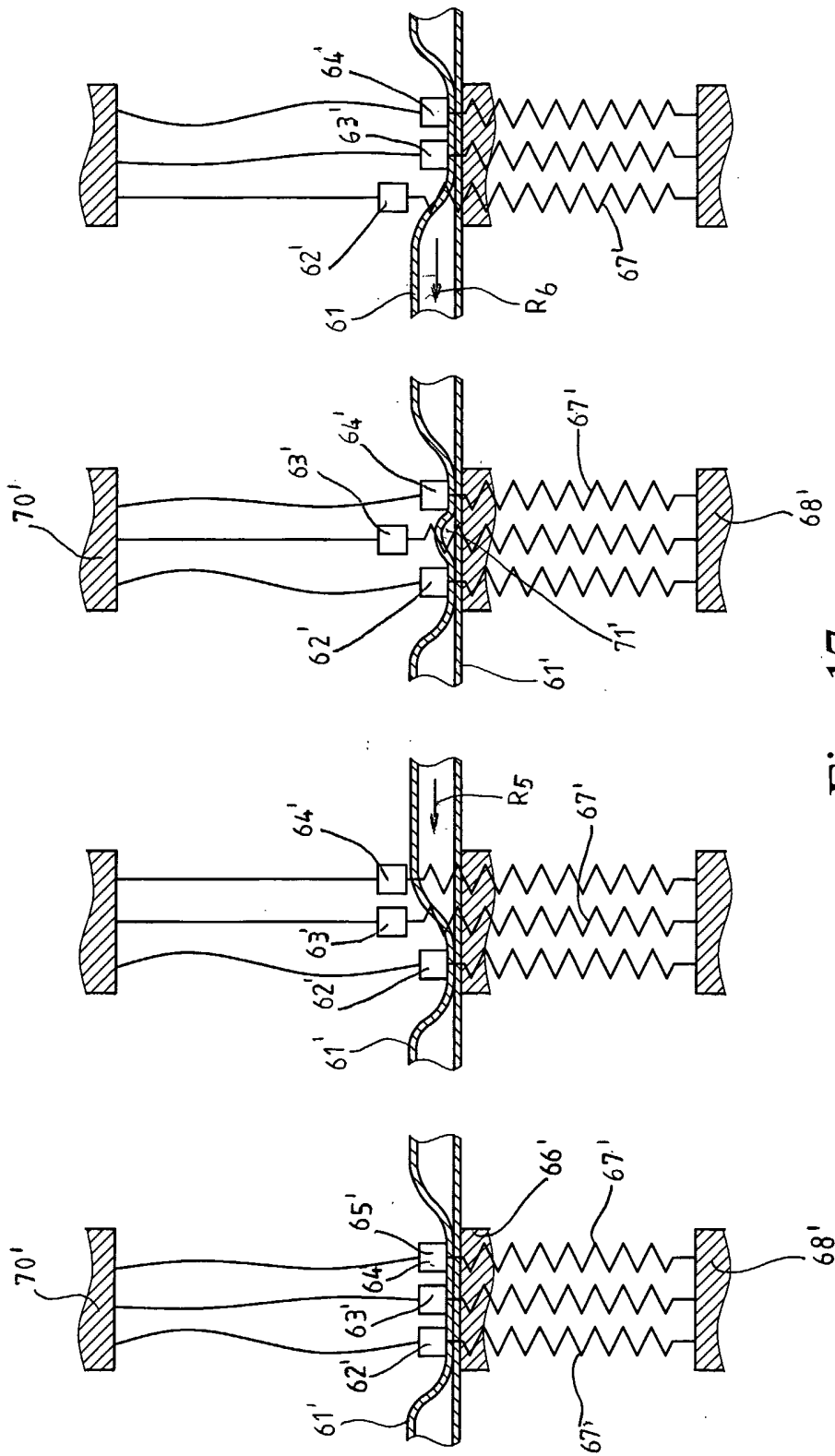

Fig. 17

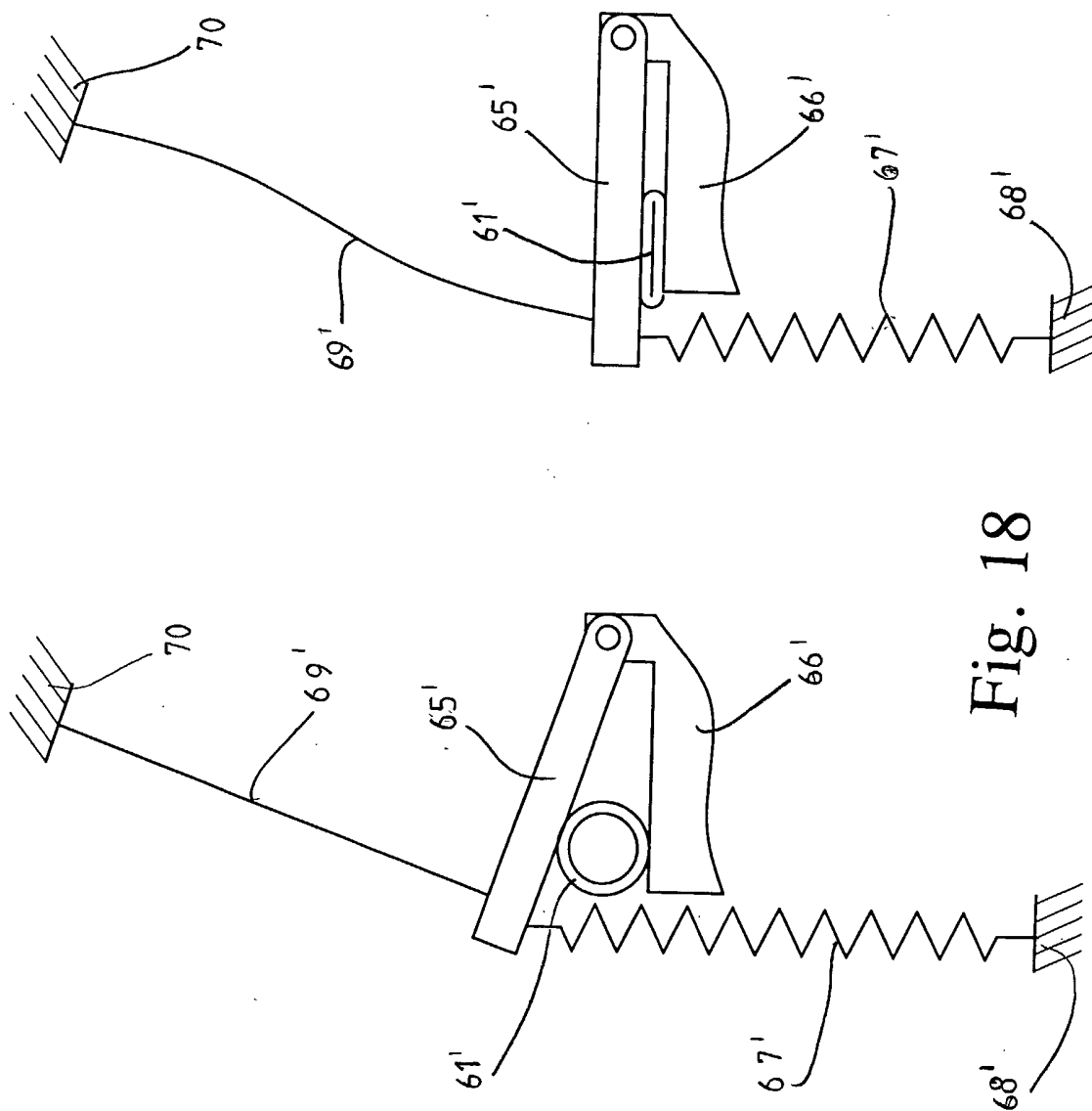

Fig. 18

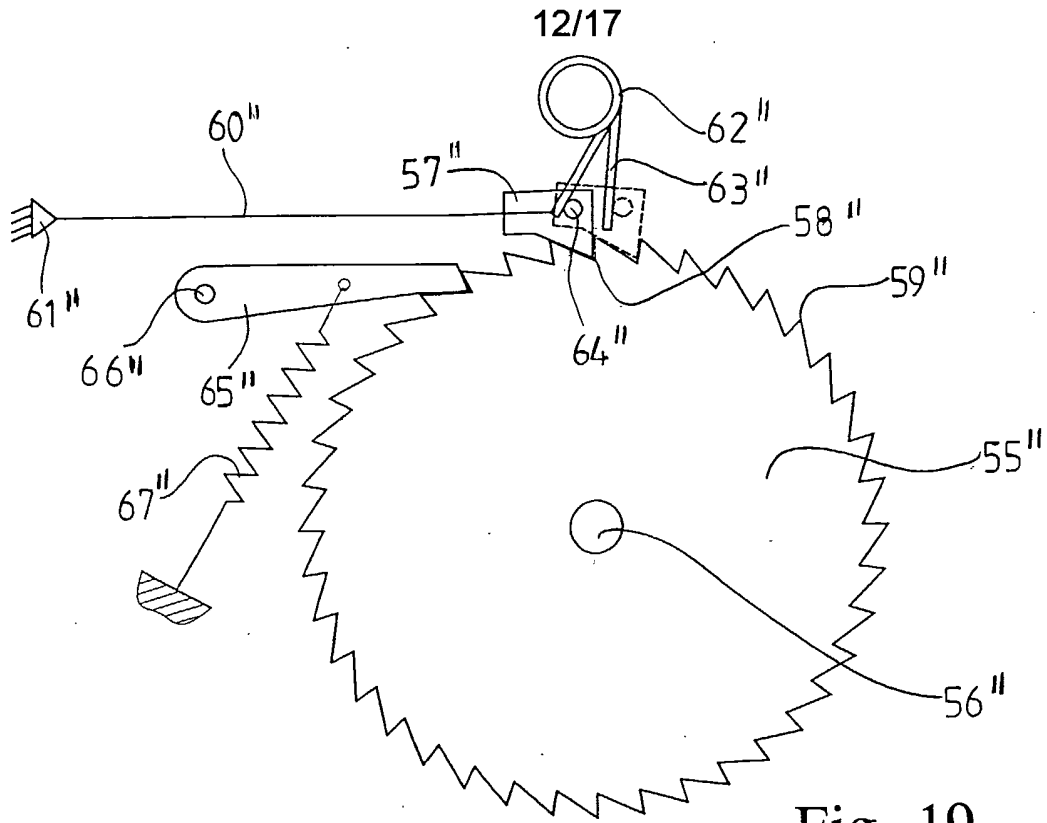

Fig. 19

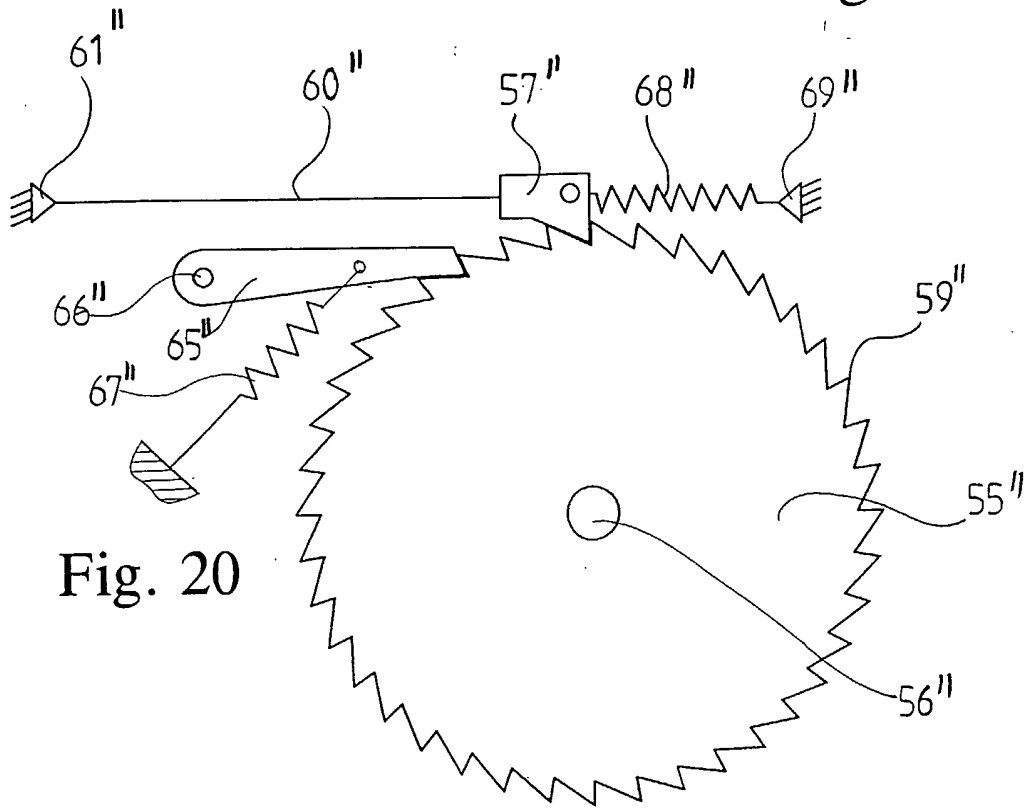

Fig. 20

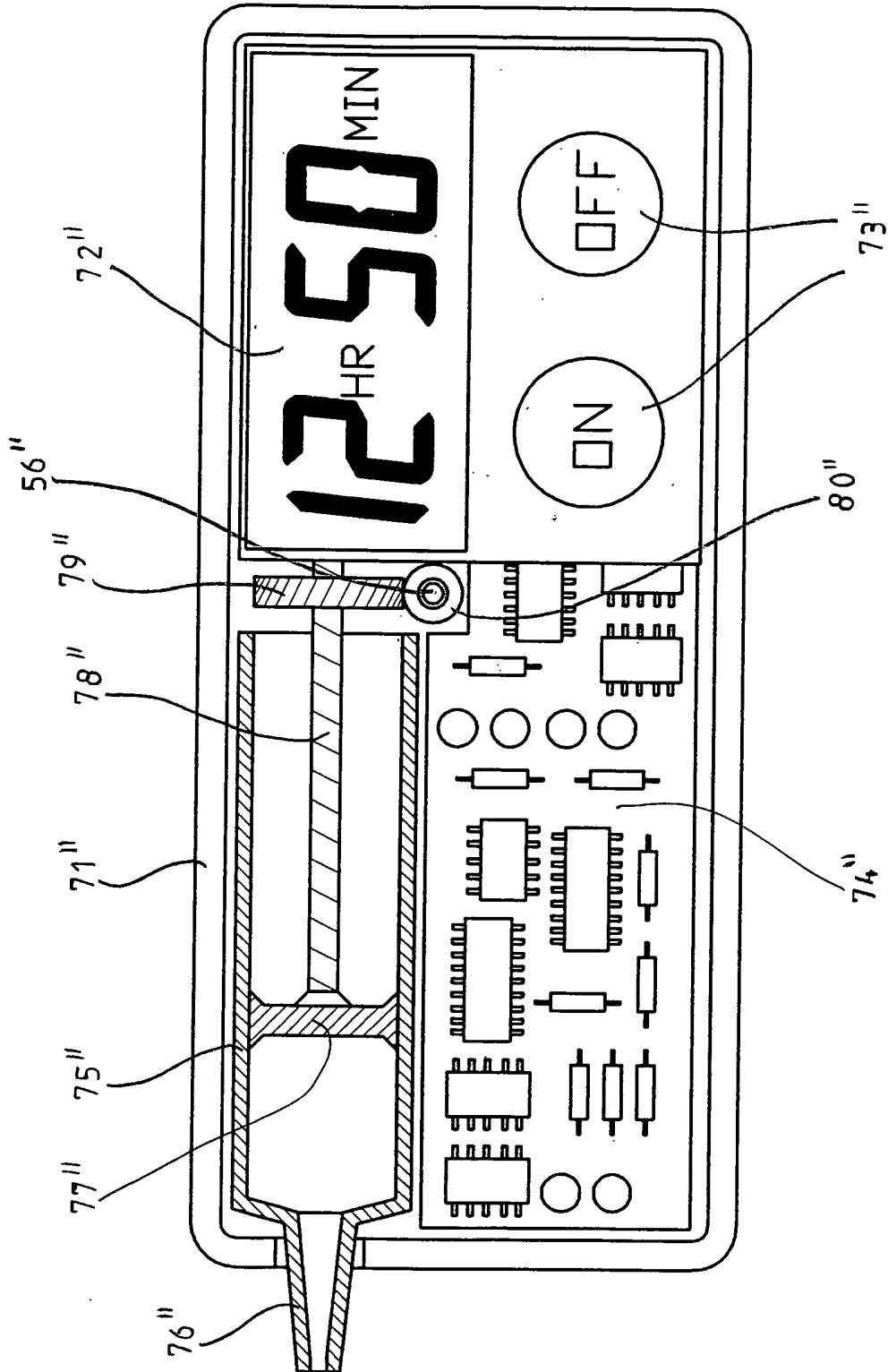

Fig. 21

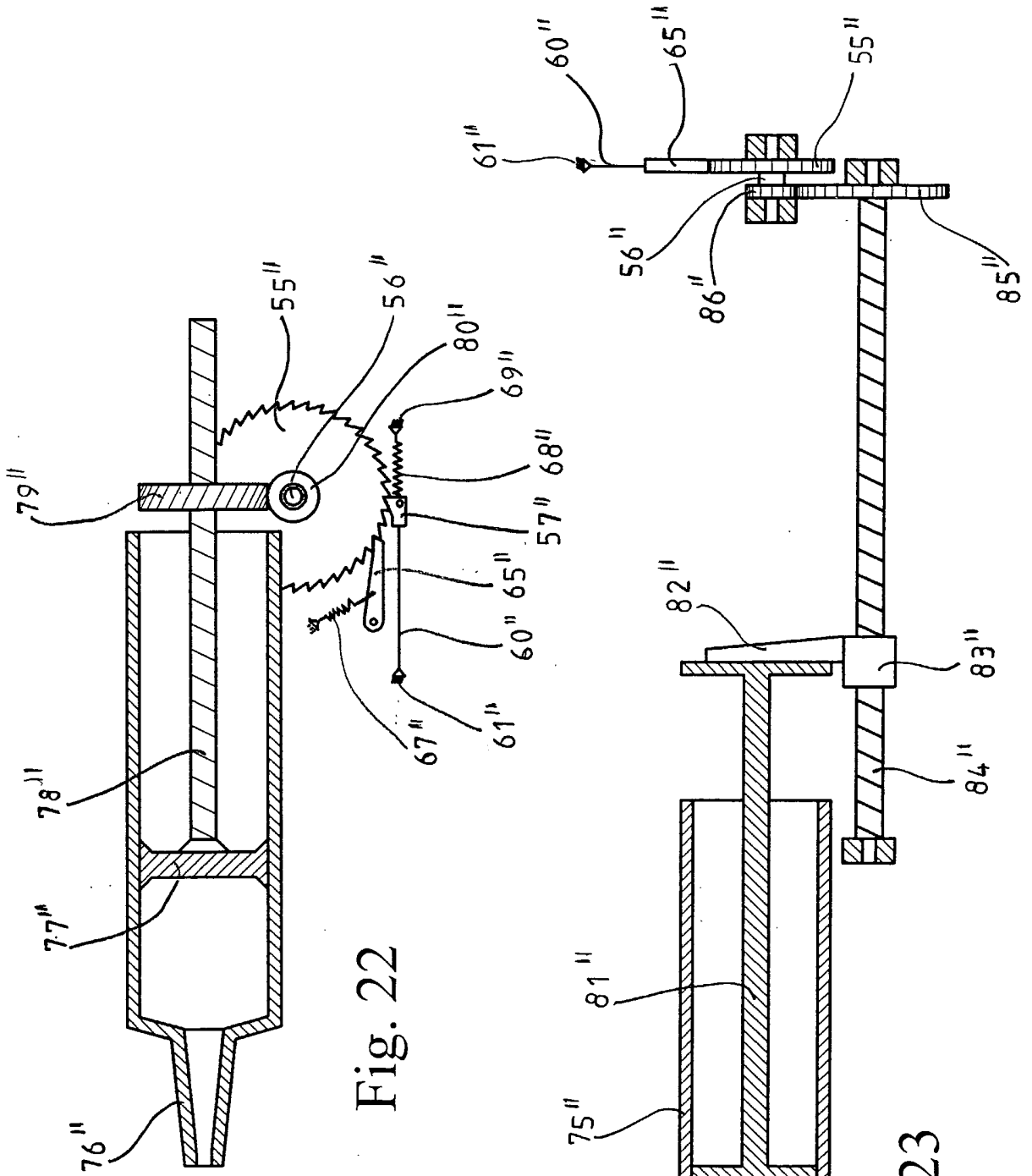

Fig. 22

Fig. 23

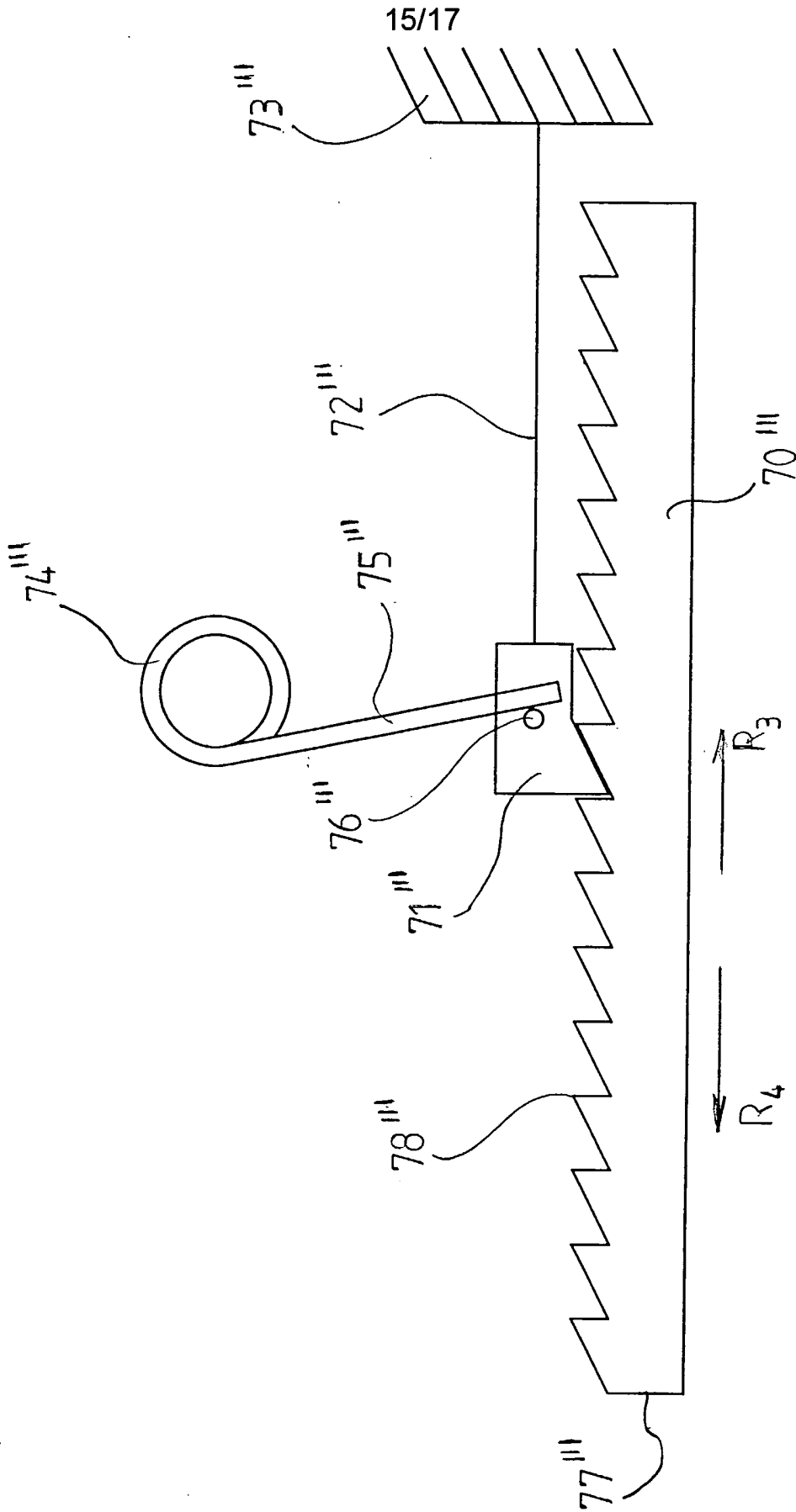

Fig. 24



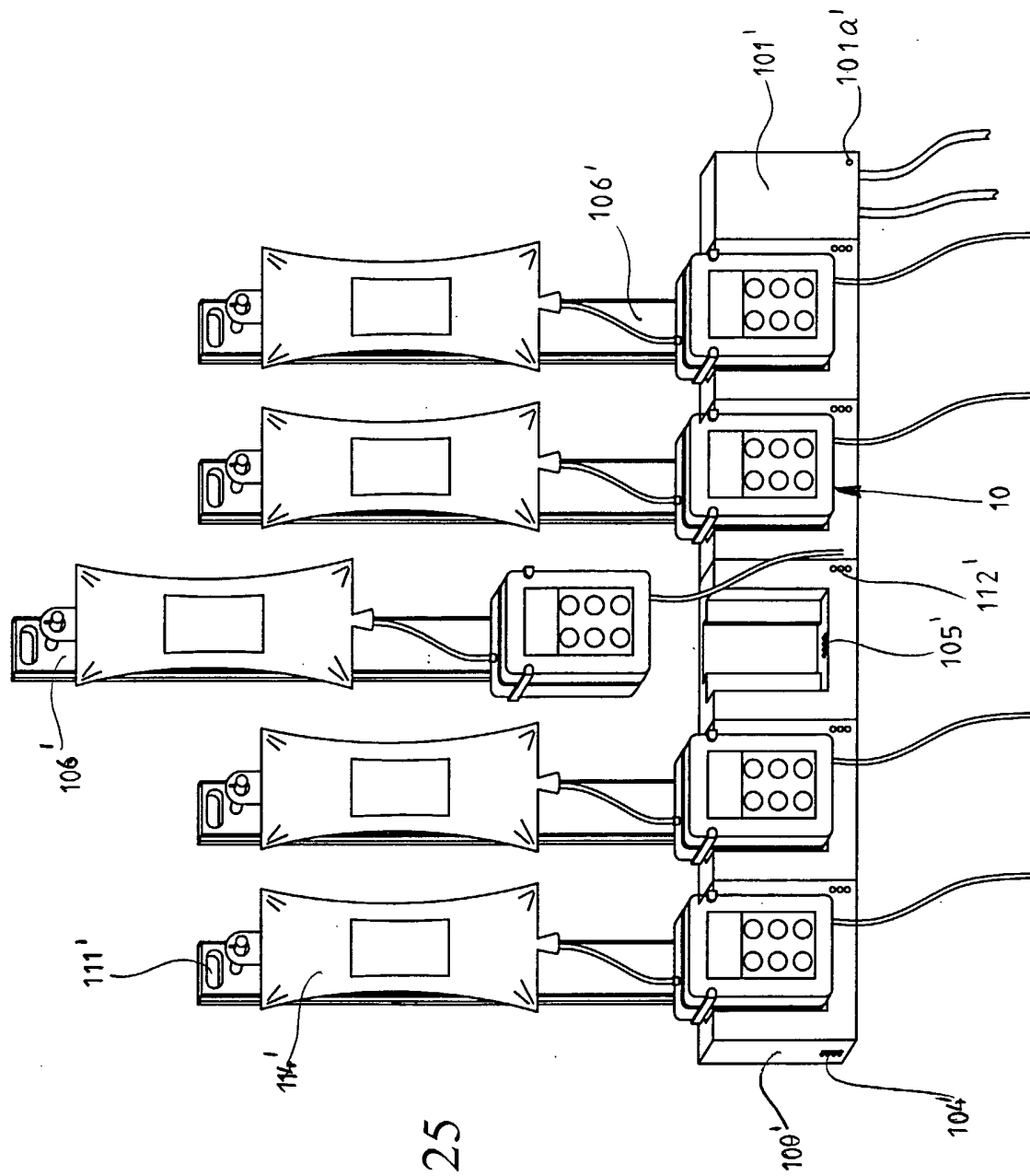

Fig. 25

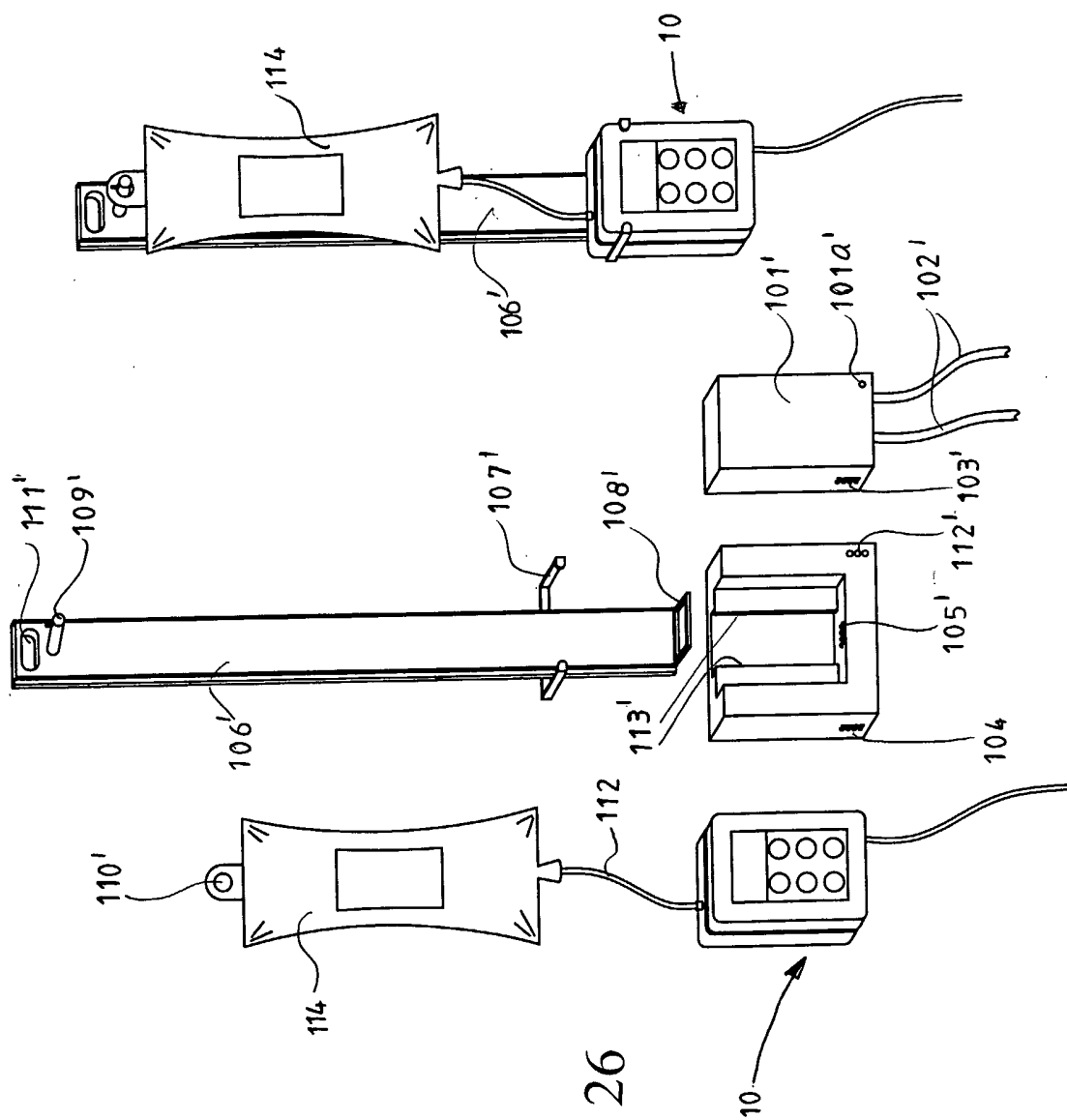

Fig. 26

## INTERNATIONAL SEARCH REPORT

 International Application No  
 PCT/DK 03/00507

**A. CLASSIFICATION OF SUBJECT MATTER**  
 IPC 7 A61M5/142 F16K7/04

According to International Patent Classification (IPC) or to both national classification and IPC

**B. FIELDS SEARCHED**
 Minimum documentation searched (classification system followed by classification symbols)  
 IPC 7 A61M F16K

Documentation searched other than minimum documentation to the extent that such documents are included in the fields searched

Electronic data base consulted during the international search (name of data base and, where practical, search terms used)

EPO-Internal

**C. DOCUMENTS CONSIDERED TO BE RELEVANT**

Category °	Citation of document, with indication, where appropriate, of the relevant passages	Relevant to claim No.
X	WO 99 21596 A (MERNOEE MORTEN) 6 May 1999 (1999-05-06) claims 1,15; figures 1-5 abstract	40,41
Y	---	1-3,37
Y	WO 99 39118 A (UNIV MICHIGAN ;GRUMMON DAVID S (US)) 5 August 1999 (1999-08-05) page 3, line 17 -page 4, line 11 abstract	1-3,37
Y	---	1-3
	DE 196 27 619 A (ORLITA PROZESSTECHNIK ORLITA G) 15 January 1998 (1998-01-15) claim 1 abstract	
	---	
	-/--	

 Further documents are listed in the continuation of box C.

 Patent family members are listed in annex.

° Special categories of cited documents :

"A" document defining the general state of the art which is not considered to be of particular relevance

"E" earlier document but published on or after the international filing date

"L" document which may throw doubts on priority claim(s) or which is cited to establish the publication date of another citation or other special reason (as specified)

"O" document referring to an oral disclosure, use, exhibition or other means

"P" document published prior to the international filing date but later than the priority date claimed

"T" later document published after the international filing date or priority date and not in conflict with the application but cited to understand the principle or theory underlying the invention

"X" document of particular relevance; the claimed invention cannot be considered novel or cannot be considered to involve an inventive step when the document is taken alone

"Y" document of particular relevance; the claimed invention cannot be considered to involve an inventive step when the document is combined with one or more other such documents, such combination being obvious to a person skilled in the art.

"&amp;" document member of the same patent family

Date of the actual completion of the international search

26 September 2003

Date of mailing of the international search report

23.10.2003

Name and mailing address of the ISA

 European Patent Office, P.B. 5818 Patentlaan 2  
 NL - 2280 HV Rijswijk  
 Tel. (+31-70) 340-2040, Tx. 31 651 epo nl,  
 Fax: (+31-70) 340-3016

Authorized officer

NILS NORDIN / ELY

## INTERNATIONAL SEARCH REPORT

International Application No  
PCT/DK/93/00507

C.(Continuation) DOCUMENTS CONSIDERED TO BE RELEVANT		
Category °	Citation of document, with indication, where appropriate, of the relevant passages	Relevant to claim No.
A	US 5 045 064 A (IDRISS SAMIR F) 3 September 1991 (1991-09-03) claims 1-4 abstract -----	1-41

# INTERNATIONAL SEARCH REPORT

International Application No.  
PCT/DK 03/00507

## Box I Observations where certain claims were found unsearchable (Continuation of item 1 of first sheet)

This International Search Report has not been established in respect of certain claims under Article 17(2)(a) for the following reasons:

1.  Claims Nos.:  
because they relate to subject matter not required to be searched by this Authority, namely:
  
2.  Claims Nos.:  
because they relate to parts of the International Application that do not comply with the prescribed requirements to such an extent that no meaningful International Search can be carried out, specifically:
  
3.  Claims Nos.:  
because they are dependent claims and are not drafted in accordance with the second and third sentences of Rule 6.4(a).

## Box II Observations where unity of invention is lacking (Continuation of item 2 of first sheet)

This International Searching Authority found multiple inventions in this international application, as follows:

see additional sheet

1.  As all required additional search fees were timely paid by the applicant, this International Search Report covers all searchable claims.
2.  As all searchable claims could be searched without effort justifying an additional fee, this Authority did not invite payment of any additional fee.
3.  As only some of the required additional search fees were timely paid by the applicant, this International Search Report covers only those claims for which fees were paid, specifically claims Nos.:
4.  No required additional search fees were timely paid by the applicant. Consequently, this International Search Report is restricted to the invention first mentioned in the claims; it is covered by claims Nos.:

### Remark on Protest

- The additional search fees were accompanied by the applicant's protest.
- No protest accompanied the payment of additional search fees.

FURTHER INFORMATION CONTINUED FROM PCT/ISA/ 210

This International Searching Authority found multiple (groups of) inventions in this international application, as follows:

1. Claims: 1-39

A SMA-infusion pump/pump unit/pump system

2. Claims: 40-41

An infusion pump system including a power supply

These groups of inventions are not so linked to form a single general inventive concept. There is no technical relationship among those inventions involving one or more of the same or corresponding special technical features.

## INTERNATIONAL SEARCH REPORT

Information on patent family members

International Application No  
PCT/DK 03/00507

Patent document cited in search report		Publication date	Patent family member(s)	Publication date
WO 9921596	A	06-05-1999	AU 9621898	A 17-05-1999
			BR 9812969	A 08-08-2000
			CA 2301534	A1 06-05-1999
			WO 9921596	A1 06-05-1999
			EP 1024844	A1 09-08-2000
			US 6270478	B1 07-08-2001
			-----	
WO 9939118	A	05-08-1999	AU 2492199	A 16-08-1999
			WO 9939118	A1 05-08-1999
			US 6260818	B1 17-07-2001
-----				
DE 19627619	A	15-01-1998	DE 19627619	A1 15-01-1998
-----				
US 5045064	A	03-09-1991	AT 117561	T 15-02-1995
			AU 647145	B2 17-03-1994
			AU 7978991	A 31-12-1991
			CA 2084191	C 04-03-1997
			DE 9190077	U1 22-04-1993
			DE 69107074	D1 09-03-1995
			DE 69107074	T2 24-05-1995
			DK 532561	T3 27-03-1995
			EP 0532561	A1 24-03-1993
			ES 2067934	T3 01-04-1995
			GR 3015395	T3 30-06-1995
			JP 7004429	B 25-01-1995
			JP 5506594	T 30-09-1993
			WO 9118633	A1 12-12-1991
-----				