

(No Model.)

2 Sheets—Sheet 1.

S. J. ADAMS.

APPARATUS FOR WITHDRAWING PATTERNS FROM SAND MOLDS.

No. 377,004.

Patented Jan. 31, 1888.

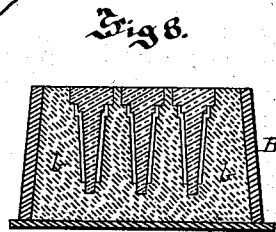
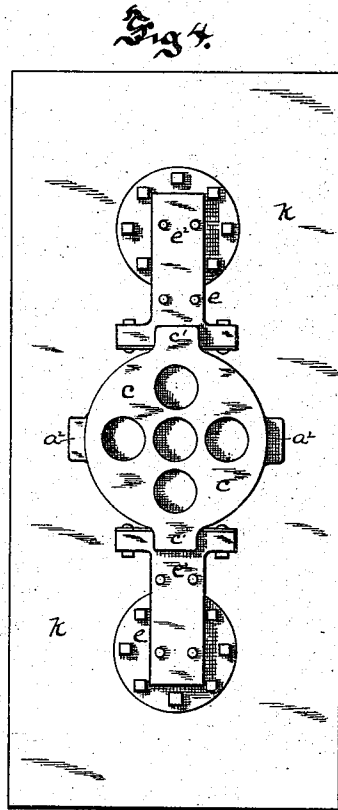
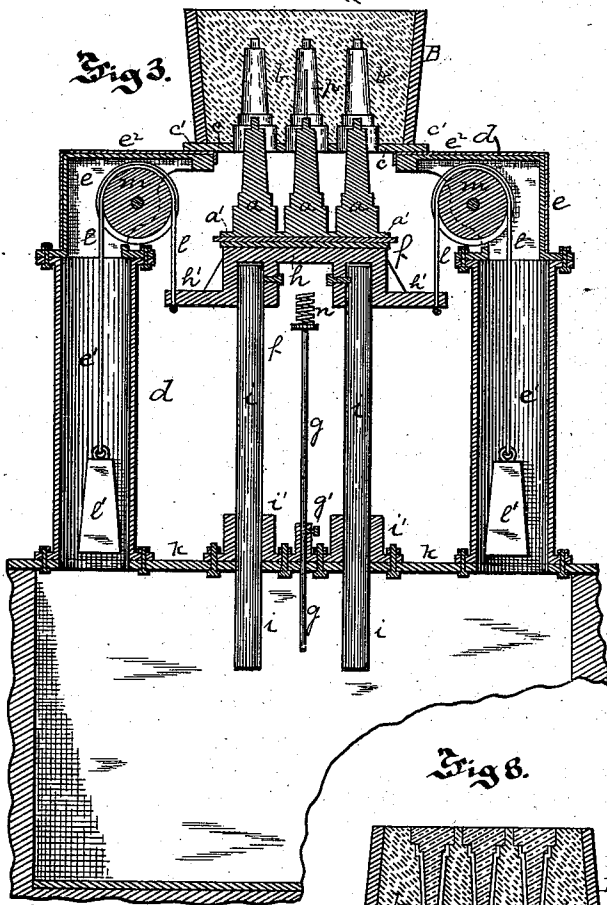
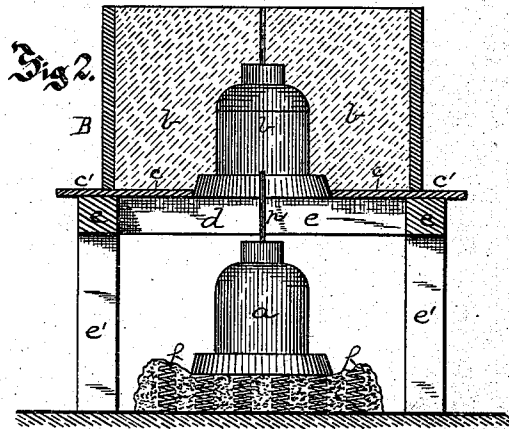
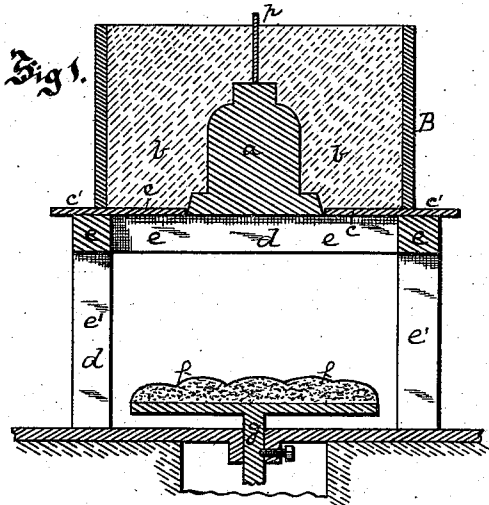

Witnesses.
Alv. Scott
W. H. Adams

Inventor.
S. Jarvis Adams.
By James J. Ray
Attorney

S. J. ADAMS.

APPARATUS FOR WITHDRAWING PATTERNS FROM SAND MOLDS.

No. 377,004.

Patented Jan. 31, 1888.

Fig 5.

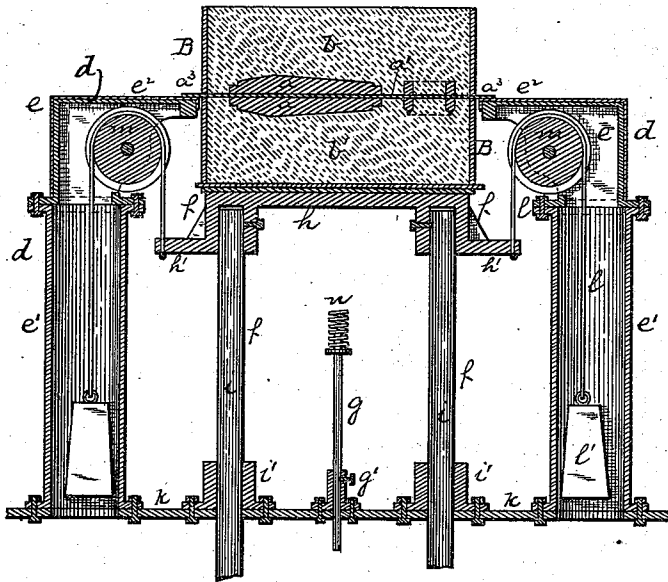

Fig 6.

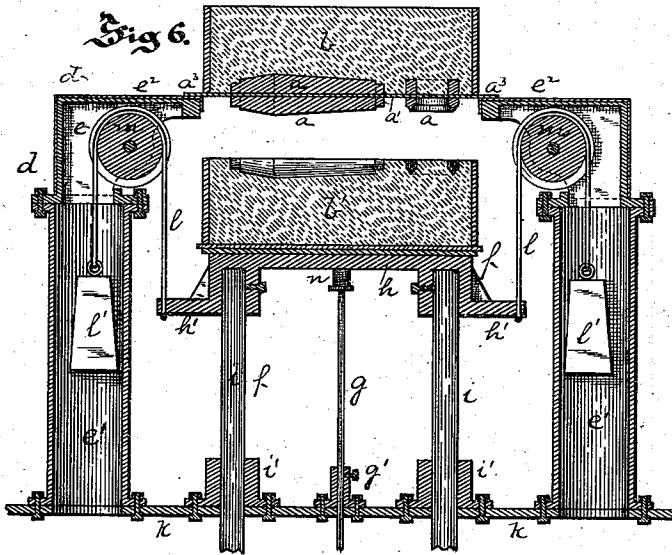
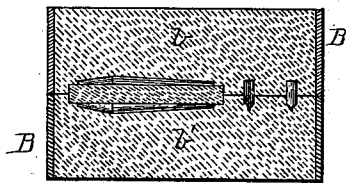

Fig 7.



Witnesses.

Wm. Scott

A. M. Smith

Inventor.

S. Jarvis Adams.

By James S. Kay
Attorney

UNITED STATES PATENT OFFICE.

S. JARVIS ADAMS, OF PITTSBURG, PENNSYLVANIA.

APPARATUS FOR WITHDRAWING PATTERNS FROM SAND MOLDS.

SPECIFICATION forming part of Letters Patent No. 377,004, dated January 31, 1888.

Application filed January 27, 1885. Serial No. 154,153. (No model.)

To all whom it may concern:

Be it known that I, S. JARVIS ADAMS, of Pittsburg, in the county of Allegheny and State of Pennsylvania, have invented a new and useful Improvement in Apparatus for
5 Withdrawing Patterns from Sand Molds; and I do hereby declare the following to be a full, clear, and exact description thereof.

My invention relates to apparatus for the
10 withdrawal or separation of patterns from sand molds. The usual manner of withdrawing patterns is to lift them out of the mold, the molder gradually becoming skilled, so that there is but a slight side movement of the
15 hand, and the mold is sufficiently perfect for many articles. In machine-molding, guide apparatus of different kinds has been employed, the pattern-plates being secured thereto and withdrawn either from the top or the bottom
20 of the sand mold; but these, on account of the entrance of the sand into the guide apparatus, will wear rapidly, and thus permit a slight side motion of the patterns, which will press the mold slightly out of true shape, and where a
25 variation of less than a hundredth part of an inch is objectionable, as in pipe-balls, wagon-boxes, and other castings, it is evident that a more perfect means of withdrawing the patterns is necessary. In employing this guide
30 apparatus it is generally necessary to turn the mold over to withdraw the pattern from above, and the weight of the pattern will, on the slight jarring of the mold necessary on turning it
35 over, cause the pattern to sag slightly and press the mold out of true circular shape. Hence it is desirable to withdraw the pattern from below; but this has heretofore been found impossible where the mold was packed by ramming or jarring. It was also found that where
40 the guide apparatus was employed in withdrawing the mold, on account of the slight side motion of the pattern, the sand packed in the corners of the pattern was liable to stick to it and be withdrawn with it, thus forming
45 irregularities in the mold and imperfections in the casting. By my invention these objections to the ordinary guide apparatus heretofore employed are entirely overcome. This I accomplish by separating the mold and pattern
50 by dropping the one from the other, as I have found that in so doing the attraction of gravitation acts perfectly to cause a withdrawal

of the pattern without in any way injuring the walls of the mold or pressing it out of shape. In causing this separation the pattern
55 may be dropped out of the sand mold; or the sand mold formed within the flask may be dropped from the pattern, as is found preferable, according to the construction of the pattern and flask. I have also provided a yielding
60 bed to receive the pattern or mold when dropped, which serves either to lower it gradually to prevent injury or to break its fall after it has dropped clear of the mold, and have provided other apparatus found desirable in
65 carrying out my improved method of withdrawing the patterns.

To enable those skilled in the art to employ my invention, I will describe the same fully, referring to the accompanying drawings, in
70 which—

Figures 1 and 2 are vertical sections illustrating the simplest means of carrying on my invention. Fig. 3 is a like view illustrating the means preferred by me for employing my
75 invention where the patterns are dropped from the sand mold. Fig. 4 is a top view of the apparatus shown in Fig. 3, without the flask and mold and patterns. Figs. 5 and 6
80 are vertical sections illustrating the dropping of the sand mold and its flask from the pattern, and Fig. 7 is a vertical section showing the two-part mold so formed. Fig. 8 is a section of a finished mold with the cores inserted
85 therein.

Like letters of reference indicate like parts in each of the figures.

The sand molds may be packed in any suitable manner, either by ramming, jarring, or pressing, the method preferred and generally
90 practiced by me being jarring, as covered by patents previously granted to me.

In forming long narrow molds, or molds formed in a single flask, as illustrated in Figs. 1 to 3, the patterns *a* generally extend up into
95 the flask *B* through a stripping-plate, *c*, fitting around the pattern at its largest diameter and acting to support the sand mold *b* in the flask when the pattern is withdrawn. In a long narrow flask the sand mold is supported by
100 the walls of the flask, and the stripping-plate is not necessary, though generally desirable. Where a nest of patterns is employed, as shown in Fig. 3, they are attached to a pat-

tern-plate, *a'*, and thus held in true line, the pattern-plate resting on the jarring or ramming table, the stripping-plate on it, and the flask on the stripping-plate, the patterns extending up through this plate into the flask. Where but one mold is made in each flask, as in making pipe-balls of from eight to eighteen inches diameter, the pattern rests on the molding-table, the stripping-plate *c* fitting around it, and no pattern-plate being necessary, as shown in Figs. 1 and 2. The stripping-plate *c* is provided with suitable lips or extensions, *c'*, to support it and the mold on the dropping-table when the pattern or pattern-plate is withdrawn, the pattern-plate being generally provided with like lips, *a''*, at right angles thereto, for carrying it to the dropping-table. The mold is dropped from the pattern when the mold is formed in two parts, *b b'*, within a partitioned flask, as illustrated in Figs. 5 and 6, or when the pattern or pattern-plate is unevenly balanced, so that one side might be liable to drop more rapidly than the other. In such cases the mold is formed in the usual manner, the pattern-plate *a'* and two parts of the flask being held in proper position by suitable guides, so that the mold is properly formed. The pattern-plate has lips *a''* to support it on the dropping-table.

The dropping-table *d* may be of any suitable construction, that shown in Figs. 1 and 2 being the simplest construction, and being generally employed by me with large heavy patterns. It consists of a frame, *e*, supported on standards *e'*, on which frame the stripping-plate *c* rests, leaving the pattern unsupported, so that it will drop out of the mold. Below the point where the pattern drops is a suitable yielding bed, *f*, the simplest form being a cushion on which the pattern drops, as shown in said figures, the cushion being a spring-mattress, sand-bag, or other yielding material. This cushion may rest on the ground, and is generally so employed with large patterns; or it may rest on a vertically-adjusted support, *g*, as shown in Fig. 1, by which the distance for the pattern to drop is regulated according to the height of the pattern.

Where a nest of molds is formed in a flask, I prefer to employ the apparatus shown in Figs. 3 and 4. In this the frame *e* of the dropping-table is supported on two hollow standards, *e'*, bolted to the bottom plate, *k*, the frame being formed of two cast-iron boxes, the top plates, *e''*, whereof extend out toward each other and form the support for the stripping-plate *c*, the lips or extensions *c'* resting on the upper ends thereof. The yielding bed *f* is formed of a platform, *h*, secured to guide-rods *i*, passing through suitable guides-boxes, *i'*, secured to the bed-plate *k*, the rods passing through the bed-plate into a pit under the dropping-table. The platform *h* has side extensions, *h'*, to which are secured the cords *l*, passing over pulleys *m*, and having weights *l'* within the hollow standards, the extension *h'* also serving to limit the upward movement of

the platform by striking against the pulleys *m*. The weights *l'* are slightly heavier than the yielding bed and its guide-rods, and sufficient to raise it to its highest position between the top plates, *e''*, when no weight is placed upon it; but when the pattern-plate and patterns rest on the platform it is at once carried down by their weight, offering substantially no resistance thereto, the yielding bed being employed simply to prevent the jarring of the pattern-plate and patterns and the consequent loosening of the connections between them, or injury to the patterns or plate, and not for positively withdrawing them. To regulate the distance for the pattern to drop, the vertically-adjustable support *g* extends up under the platform and is adjusted by the set-screw *g'*, so that the platform rests on it as soon as the patterns drop clear of the mold. To prevent jar to the platform or the pattern or mold resting thereon, the support *g* has a cushioning-spring, *n*, at the upper end. This is more necessary where the mold is dropped from the pattern, as illustrated in Figs. 5 and 6, to prevent the jarring and injury of the sand mold. The dropping-table employed where the mold drops from the pattern is substantially the same as shown in Figs. 3 and 4, varying only in proportion according to the size of the flask.

In carrying on the process of withdrawing the patterns where a single mold is made in the flask, as shown in Figs. 1 and 2, after the compacting of the mold the flask is slid onto the dropping-table *d* over the cushion or yielding bed *f*, the stripping-plate *c* supporting the flask and the sand mold in the proper position to allow the pattern to drop vertically out of the mold, the binding of the sand holding the pattern in place until it is entirely unsupported. The pattern is generally heavy enough to drop out as soon as left unsupported; but it is sometimes held by the binding of the sand, and in that case the molder simply presses on the rod *p*, extending through the mold from the top of the pattern, this rod being employed to give an initial movement to the pattern, when it will continue to descend by its own weight. I have found that the pattern drops out without in any way pressing the mold out of shape, the attraction of gravitation acting perfectly to withdraw the pattern, and the walls of the mold also forming the most perfect guide for its withdrawal that can be obtained, this guide being made each time a mold is made, and thus doing away with the wearing of the guides where any form of separate guide apparatus is employed. It is also found that the difficulty of the sand sticking in the corners of the pattern and being withdrawn by it is entirely overcome.

The sand of the mold is supported by the stripping-plate *c* where one is used, which is removed after the mold is turned over to receive its core. As it is not necessary to turn the mold over before removing the pattern, there is no opportunity for the pattern to sag and press the mold out of shape. The pat-

tern drops onto the yielding bed *f*, and injury to it is thus prevented. Where a nest of patterns is withdrawn, as shown in Fig. 3, after the mold is formed it is placed on the dropping-table *d*, the extensions *c'* of the stripping-plate *c* resting on the top plates, *e*², and the yielding bed or platform is held by the counterbalancing-weights up against the pattern-plate. The patterns then drop out, as above described, an initial movement being imparted to them through the rod *p*, if necessary, and they carry down with them the yielding bed *f*, their descent being checked by the support *g*. The flask is then turned over, the stripping-plate removed, and the cores inserted, as shown in Fig. 8.

When the mold is dropped from the pattern, where a partible mold is used, after molding in the usual manner, it is placed by hand on the dropping-table, the drag resting on the yielding platform, and the extensions *a*³ of the pattern-plate resting on the top plates, *e*², and when the drag is released by the hand it will drop from the pattern-plate, as illustrated in Fig. 6, the yielding bed simply acting to prevent injury to the mold. The drag is then removed, the pattern-plate and cope turned over, and the cope dropped from the pattern-plate in the same manner, when it can be placed on the drag, any core required being first inserted, as shown in Fig. 7.

My invention has the advantages of simplicity, cheapness, adaptability to a great variety of work, and the apparatus shown, being entirely separate from any molding apparatus, can be used by several molders, even when forming molds of different shapes.

I do not claim in this application the dropping of the pattern from the mold by its own weight and guided only in its withdrawal by

the walls of the mold-form, as that forms the subject-matter of a separate application filed by me November 1, 1887, Serial No. 253,973, which is a division of this application.

What I claim as my invention, and desire to secure by Letters Patent, is—

1. In apparatus for withdrawing patterns from sand molds, the combination of a supporting-table, a yielding bed, and a vertically-adjustable support therefor, substantially as and for the purposes set forth.

2. In apparatus for withdrawing patterns from sand molds, the combination of a supporting-table, a yielding bed having suitable guide apparatus, counterbalancing apparatus, and a vertically-adjustable support for said yielding bed, substantially as and for the purposes set forth.

3. In apparatus for withdrawing patterns from sand molds, the combination of a supporting-table, a yielding bed having suitable guide apparatus, counterbalancing apparatus, and a support for said yielding bed, having a cushioning-spring at the upper end thereof, substantially as and for the purposes set forth.

4. In an apparatus for withdrawing patterns from sand molds, the combination, with the mold, of a pattern extending from the base of the flask toward the top and adapted and arranged to be dropped out of the mold, and a rod extending through the mold to the pattern, whereby an initial movement is imparted to the pattern, substantially as and for the purpose set forth.

In testimony whereof I, the said S. JARVIS ADAMS, have hereunto set my hand.

S. JARVIS ADAMS.

Witnesses:

JAMES I. KAY,
J. N. COOKE.