

March 5, 1935.

W. L. PADEN

1,993,452

CASH REGISTER

Filed Dec. 29, 1930

4 Sheets-Sheet 1

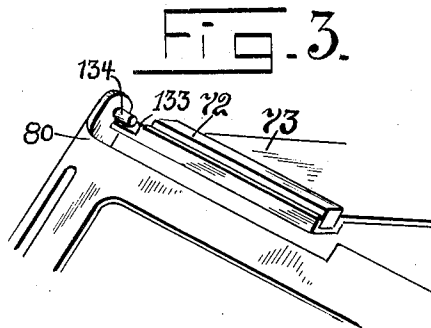
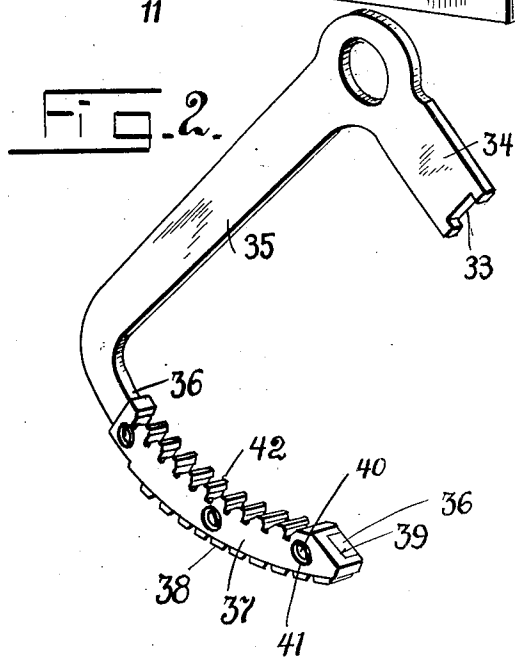
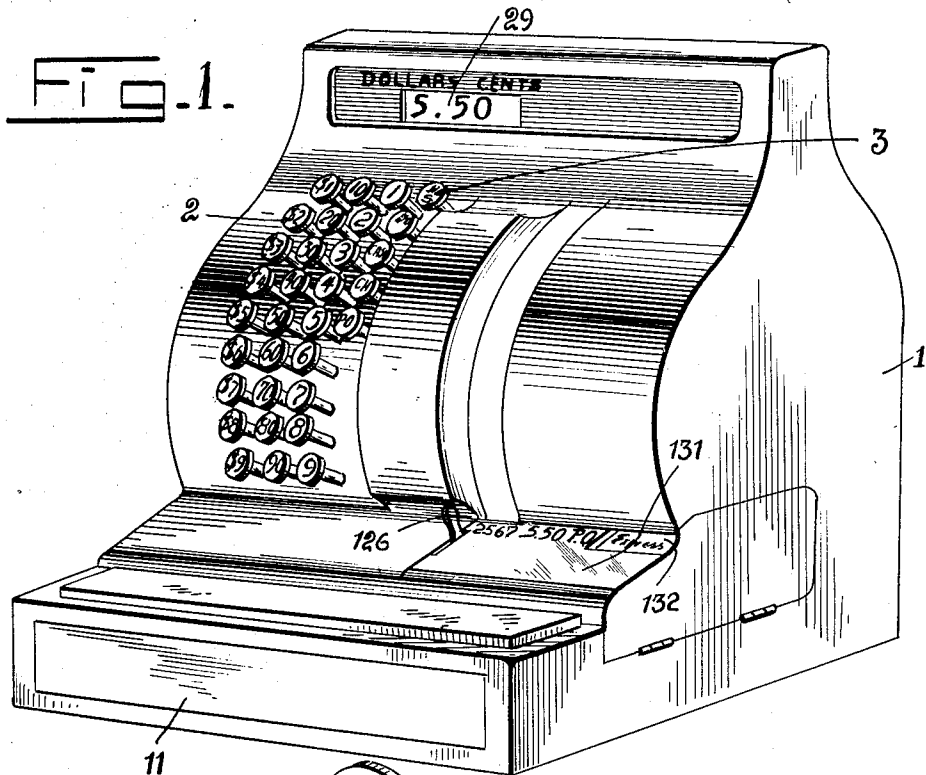

INVENTOR  
*William L. Paden*  
BY *H. W. Baker*  
ATTORNEY

March 5, 1935.

W. L. PADEN

1,993,452

CASH REGISTER

Filed Dec. 29, 1930

4 Sheets-Sheet 2

Fig. 4.

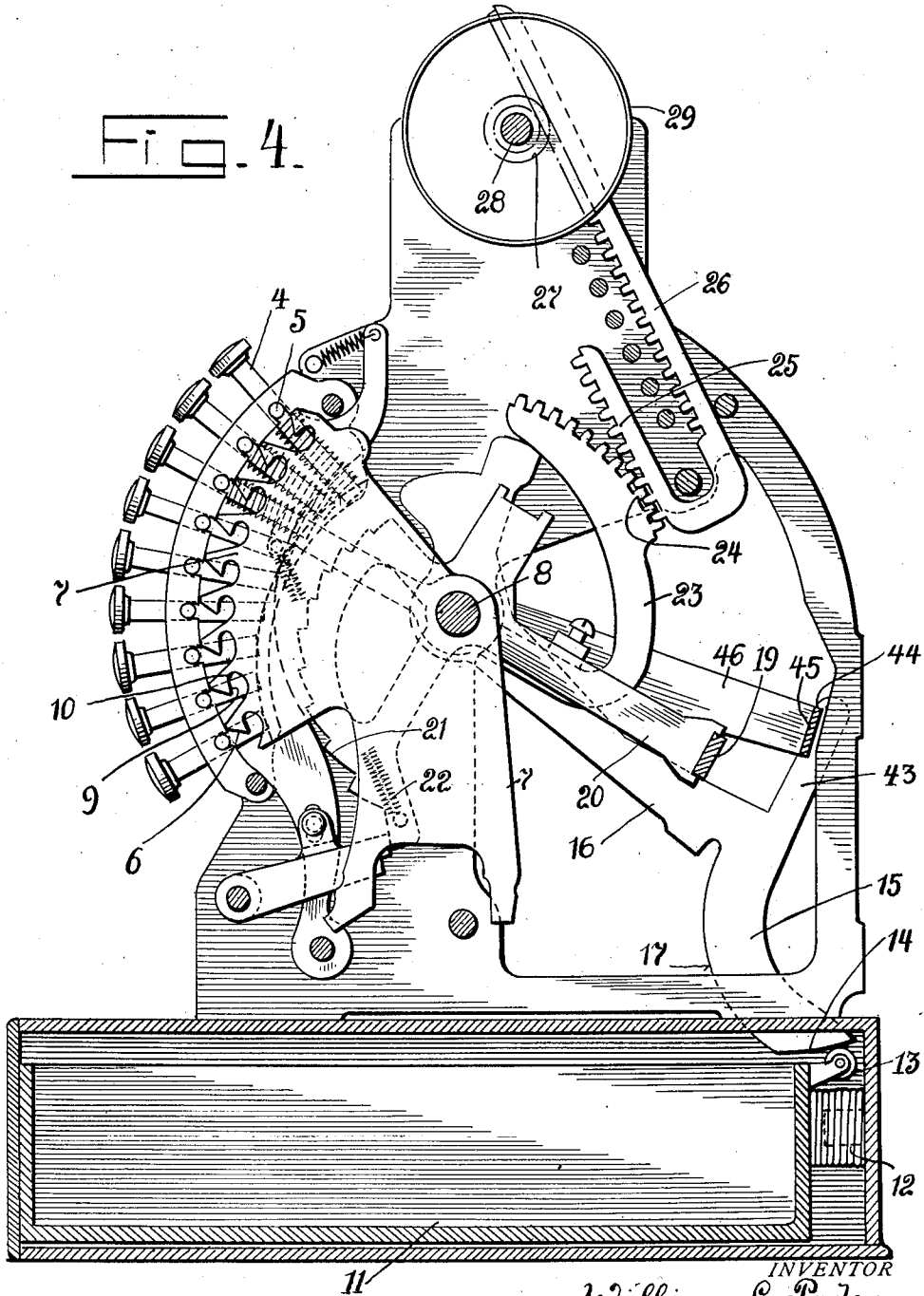

INVENTOR  
BY *William L. Paden*  
*H. W. Baker*  
ATTORNEY

March 5, 1935.

W. L. PADEN

1,993,452

CASH REGISTER

Filed Dec. 29, 1930

4 Sheets-Sheet 3

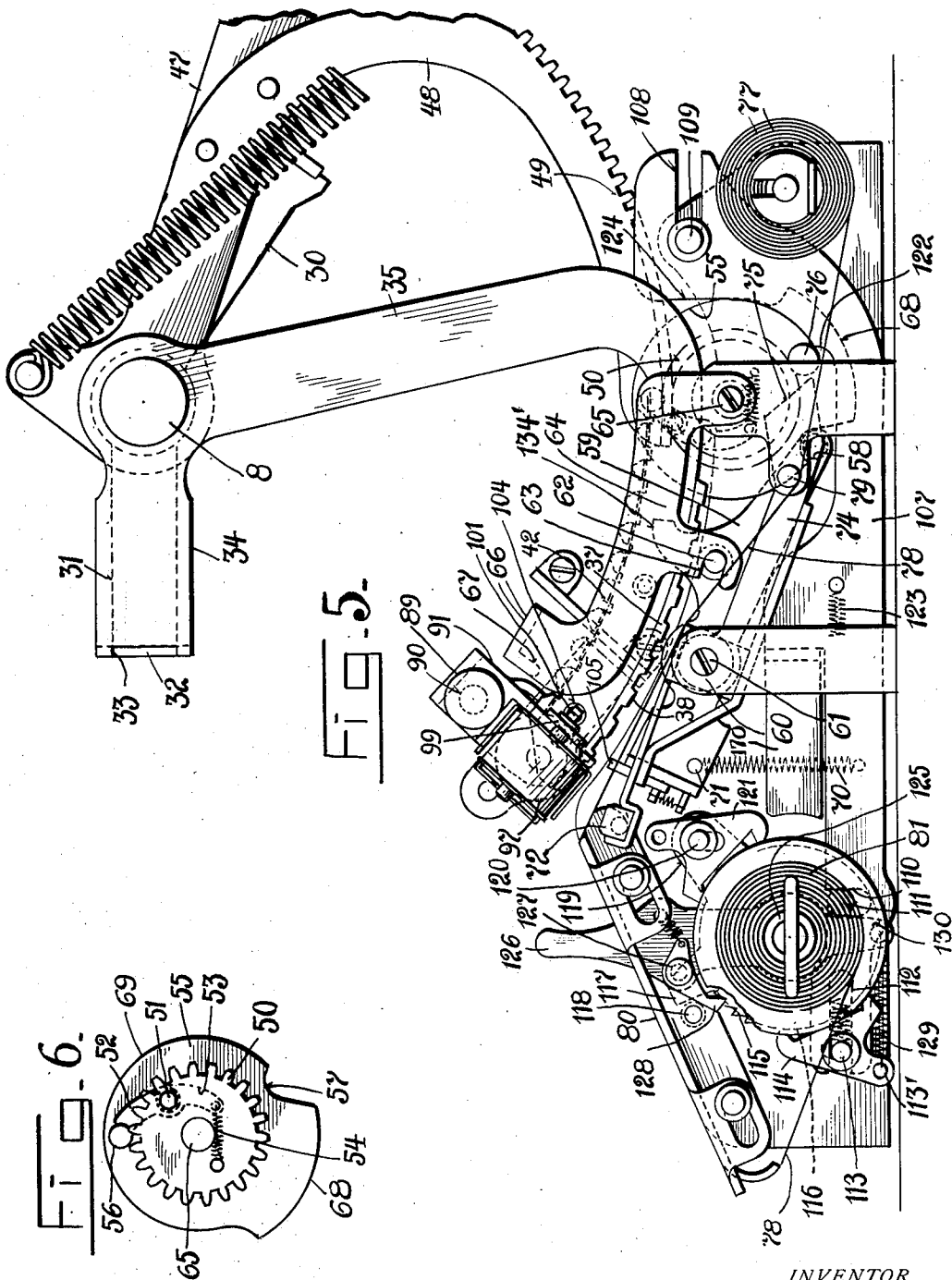

INVENTOR  
William L. Paden  
H. W. Baker  
ATTORNEY

March 5, 1935.

W. L. PADEN

1,993,452

CASH REGISTER

Filed Dec. 29, 1930

4 Sheets-Sheet 4

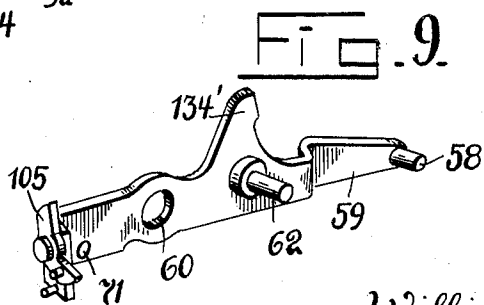
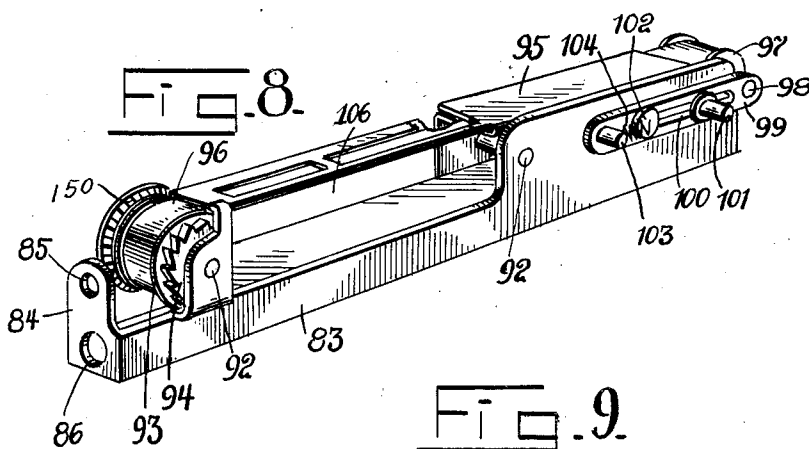
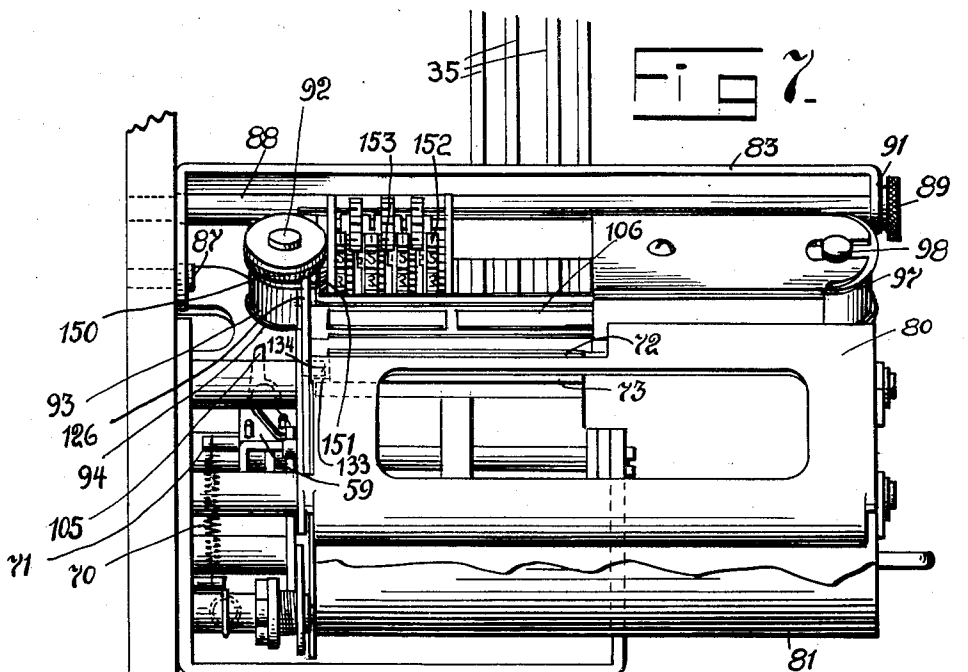

BY

INVENTOR  
*William L. Paden*  
*H. W. Baker*  
ATTORNEY

# UNITED STATES PATENT OFFICE

1,993,452

## CASH REGISTER

William Leonard Paden, Dayton, Ohio, assignor,  
by mesne assignments, to Central United National Bank, Cleveland, Ohio, as trustee

Application December 29, 1930, Serial No. 505,271

5 Claims. (Cl. 235—4)

The object of this invention is to provide an improved cash register, in which is incorporated a detail printer which is drawer operated, which printer records, by means of type, the amount of each transaction as well as the class thereof, such as, "No sale", "Received on account", "Cash", "Charge", or "Paid out". Another object of this invention is to provide means whereby the distance between successive impressions will be uniform. Another object of the invention is to provide means whereby the paper may be fed forward manually. Another object of the invention is to provide a writing table so positioned that written notations may be made adjacent any item on the record, and to provide means whereby such written notations will be inaccessible to the operator after the machine has been again operated.

In the drawings:

Figure 1 is a perspective view of the front and side of the register.

Figure 2 is an elevational view of the printer segment arm having the printing segment thereon.

Figure 3 is a fragmentary view of the platen, the supporting arm therefor and the writing table.

Figure 4 is a side elevational view taken through the middle of the register showing certain parts in cross section.

Figure 5 is an elevational view of the right hand end of the printing mechanism.

Figure 6 is a detailed view of the driving gear.

Figure 7 is a front view of the printing mechanism.

Figure 8 is a perspective view of the inking ribbon carrying mechanism.

Figure 9 is a perspective view of a controlling lever.

The register 1 is provided with amount keys 2 and class keys 3. In Figure 1, I have shown three rows of amount keys so that the registering capacity of the machine would be \$9.99. Additional banks of keys could be added as desired so as to make the registering capacity any amount. In like manner, I have shown only five class keys to register "No sale", "Received on account", "Cash", "Charge", and "Paid out". Any one or more of these keys may be omitted as desired and additional keys added to suit the requirements of the customer.

Each of these keys is provided with a stem 4 carrying a pin 5 which, when depressed, engages a cam surface 6 on a locking plate 7. The locking plate 7 is pivoted on the main shaft 8. When any key is pressed inwardly, its pin 5 engages the

cam surface 6 and rocks the locking plate 7 in a clockwise direction until the pin passes the nose 9 carried by the locking plate 7. The locking plate 7 is immediately thereafter rotated anticlockwise by means of gravity, or any suitable means so that the pin rests in the cut away portion 10 and the key is therefore held depressed. When the class key is subsequently depressed, the drawer is released by any well known mechanism such as that shown in the patent to Wells, 1,156,955, patented October 19, 1915. When the drawer 11 is released, it is propelled forward by means of the spring 12, and the roller 13, carried by the drawer rolls along the surface 14 of the arm 15, carried by the control arm 16. As long as the roller 13 is beneath the said surface 14, the control arm 16 cannot be lowered, but as soon as the roller 13 passes beyond the left hand end of the surface 14, the control arm 16 rotates clockwise as shown in Figure 4, propelling the drawer, while the roller 13 is in contact with the surface 17 of the said arm 15. The control arm 16 supports on its upper surface a number of bails 19, there being one such bail for each bank of keys as shown in the said patent. Each of these bails is connected to a lever 20 pivoted on the main shaft 8 and extending beyond the same, forming a stepped plate 21, there being nine such steps with the lowermost one projecting the greatest distance from the shaft 8 and each step above the lowermost one being graduated closer to the shaft 8. The uppermost key represents the lowermost denomination, such as 1, and each succeeding key represents the next higher number of that series of digits. The right hand set of keys runs from 1 to 9 while the next set of numeral keys runs from 10 to 90. If the numeral key representing the lowest digit is depressed, which would be the top key, the stepped plate 21 is permitted to rotate to the lowermost step. If the key representing 2 is depressed, the stepped plate 21 is permitted to rotate through eight steps. It is caused to rotate by gravity or by means of a spring 22. Secured to each one of the levers 20 is an arm 23 provided with a segmental gear 24 which actuates a rack rod 25 connected to a rack rod 26 which meshes with pinion 27 carried by the shaft 28 which pinion is connected to a visible indicator 29, which indicates the amount being registered.

The end of each bail 19 nearest the printing mechanism is attached to a lever 30 mounted on a shaft 8 and projects beyond the said shaft forming an arm 31 as shown in dotted lines in Figure 5. Each of the arms 31 is bent outwardly forming an arm 32 which fits in a recess 33 of an arm

34 pivoted on shaft 8 and which arm is extended forming a printing segment arm 35, secured to an arcuate arm 36. Each of the arcuate arms 36 is provided with a carrier 37 provided with printing type 38. The carrier 37 is provided with an arcuate channel 39 which receives the arm 36. The carrier 37 and arm 36 are slightly adjustable relative to each other by means of pins 40 carried by the arm 36, which project through holes 41 in the carrier 37 which holes are somewhat larger than the pins. On the upper surface of the carrier 37, there are nine teeth 42.

It is obvious that the respective keys determine the extent of rotation that the levers 20 can rotate and since the levers 20 are connected to the arms 36, the said arms 36 will be positioned corresponding to the keys depressed, and that the selected printing type are thus positioned. This is true regardless of whether the arcuate arm 36 is attached to one of the amount keys or one of the class keys. The printed impression is taken when the drawer is being closed as will be hereinafter described.

The control arm 16 has an upstanding extension 43 provided with a cut away portion 44 which receives a bar 45 which is connected to a brace bar 46, all of which parts move with the control arm 16. The bar 45 is provided with a radial extension 47 pivoted on shaft 8. The extension 47 is secured to arm 48 provided with an arcuate rack 49, which engages and actuates gear 50, the parts being so proportioned that the gear 50 is given one complete revolution in an anti-clockwise direction as shown in Figure 5, when the drawer is being opened and is moved back to its original point when the drawer is being closed. Figure 6 shows the reverse side of the gear 50 from that shown in Figure 5, so that in Figure 6 the gear 50 would be rotated in a clockwise direction when the drawer is being opened and in an anti-clockwise direction when the drawer is being closed. The gear 50 is provided with a stud 51 which carries a pawl 52 having a tail 53 to which is connected a spring 54. Considering Figure 6, as the drawer is being opened and the gear 50 rotates in a clockwise direction, the pawl 52 performs no function and does not transmit its motion to the disk 55. After it has completed its revolution, the pawl 52 has passed beneath the pin 56 carried by the disk 55. When the drawer is being closed, the pawl 52 engages the pin 56 rotating the disk 55 with the gear 50, so that the disk 55 is given one complete revolution when the drawer is being closed and remains stationary when the drawer is being opened.

The disk 55 is provided with a cut away portion 57 in which a pin 58 is normally seated, which pin is carried by a controlling lever 59 pivoted at 60 on a shaft 61. The controlling lever 59 is provided with a pin 62, which is received in a recess 63 in a depending portion of a lever 64 pivoted on a shaft 65. There is a similar lever on the side of the printing mechanism nearest the machine but this lever is not shown as it is a duplicate of the lever shown in Figure 5. These two levers are connected by a cross bar 66 having an aligning finger 67. It will be remembered that the disk 55 is stationary while the drawer is being opened and while the type carrier 37 is being adjusted. As the drawer is closed, the disk 55 by its rotation in a clockwise direction, as viewed in Figure 5, cams the pin 58 out of the recess 57 in the disk 55, thereby lowering the pin 62 which thereby pulls downwardly on the lever 64 and moves the aligning finger 67 into the

nearest recess between the teeth 42 on the carrier 37. This movement of the carrier 37 and type thereon relative to the arm 36, is permitted by the pins 40 being smaller than the holes 41. By the above described means, the type are aligned so that all the printing characters which are to print will be in the same printing line. The arm 134' carried by the controlling lever 59, by engagement with the surface 68 of the disk 55 prevents overthrow movement of the said lever.

The printing now takes place as will be hereinafter described and after the printing is completed, the pin 58 passes off of the surface 68 and drops to the reduced circumference 69 of the disk 55. A spring 70 connected to a pin 71 carried by the controlling lever 59 maintains the pin 58 in engagement with the disk 55 so that when the surface 68 of the disk 55 passes beyond the pin 58 the spring 70 will elevate the lever 64 and thereby remove the aligning finger 67 from engagement with the teeth 42 so that the printing characters may be returned to their zero or normal position.

The platen 72 is mounted on a table 73 pivoted on the shaft 61 which is provided with an arm 74 which terminates in the cam surface 75 which is engaged by a pin 76 on the disk 55. As soon as the drawer commences its inward movement, the pin 58 causes the type to be aligned as above described and immediately thereafter the pin 76 engages the cam surface 75 rotating the arm 74 downwardly and thereby raises the platen 72, so that the printing takes place immediately after the type are aligned.

A record supply roll 77 supplies the paper 78 which paper passes under a guide 79 mounted on a fixed part of the machine and thence over the table 73 and across the autographic table 80 from whence it passes to a paper take-up roll 81.

A ribbon carrier is shown in Figures 5 and 8. In Figure 5, it is shown in its normal position and in Figure 8 it is shown upside down. It consists of an angle plate 83 provided with a flange 84, in which are cut two holes 85 and 86. The hole 85 receives a stud 87 carried by the frame of the machine, and the hole 86 receives a bar 88 which at its outer end receives a knurled screw threaded tap 89. The bar 88 also passes through a hole 90 in the flange 91 carried by the other end of the angle plate 83. The angle plate 83 is provided with stud shafts 92 one of which supports a roller 93 and a ratchet 94 and a bevel gear 150. The studs also support a frame 95 which guides the endless ribbon 96. The other roller 97 is mounted on a shaft 98 carried by a slide bar 99 provided with a slot 100 which receives a pin 101 and a stud 102, both of which are mounted on the angle plate 83. The slide bar 99 is provided with a pin 103, and a spring 104 connects the pins 101 and 103, thereby urging the roller 97 outwardly and maintaining the ribbon under tension. The controlling lever 59 is provided at its outer end with a pawl 105 which, when the controlling lever is actuated, engages the ratchet 94 and advances the ribbon one step. If desired the said rollers may be made of absorbent material as is commonly known in the art, so as to ink the ribbon.

In any operation of the machine, the type which will be used in printing will advance through the opening 106 in the ribbon carrier so that the type will be immediately above the ribbon which will be directly above the platen. The paper passes between the platen and the ribbon, and it is therefore apparent that the proper type

will, first, move into the proper printing position; second, the type will be aligned; third, an impression is made; and, fourth, the ribbon is advanced.

5 Means will now be described whereby the paper is advanced after it has received its printing impression. A slide bar 107 is provided with a slot 108 which receives a pin 109 carried by a fixed part of the machine. The said slide bar is also  
10 provided with a vertical slot 110 which receives a pin 111, and with a slot 112 which receives a pin 113. The pins 113 and 109 guide the said slide bar. Mounted on the pin 113 is a holding dog 114 which engages a ratchet 115 to prevent  
15 retrograde movement. The pin 111 is carried by a disk 116 provided with a stop arm 117 which at the limit of its movement, engages a stop pin 118 carried by a fixed part of the machine. It is also provided with a pawl carrying arm 119, provided with a pin 120 on which is mounted a one way pawl 121 which engages the said ratchet wheel 115. When the pin 76 moves to the left as viewed in Figure 5, the said pin is lowered in an arcuate path into a depression 122 in the slide bar 107 and then moves on to the left as viewed in the said figure, while the spring 123, secured to said slide bar and to a fixed part of the machine moves the slide bar to the left and thereby rotates the arm 119. Its pawl now imparts no motion to the ratchet 115 for it simply rides over its teeth. When the pin 76 reaches the wall 124 of the slide bar, it picks up the said slide bar and moves it to the right, thereby rotating the arm 119 and the pawl picks up the teeth of the ratchet 115 and rotates the same. This operation takes place after the printed impression has been made. Secured to the ratchet 115, is the paper takeup shaft 125 to which the paper is secured by any well known means.

40 The paper may also be advanced manually by the operator pulling forward on a hand lever 126 mounted on the shaft 125, which lever is provided with a pin 127 on which is mounted a pawl 128. As the lever 126 is pulled forwardly, the said pawl engages the ratchet 115 and advances the paper a distance corresponding to the distance the lever is pulled forward. When the lever is released, it is returned to its original position by means of a spring 129 connected to a pin 130, carried by the said lever, and to the pin 113'.

As will be noted in Figure 5, the slide bar 107 is provided with an arm 170 which when the bar is moved to the left as viewed in said figure engages the roll of paper 81, thereby limiting the amount of movement of the bar 107 according to the diameter of the roll of paper which has been wound onto the receiving roll 81.

60 The autographic table 80 is positioned beneath a glass 131 which is provided with an opening 132 through which the operator may write on the record strip. As will be seen from the Figures 1 and 5, the printing does not take place where the impression on the record would be  
65 beneath the opening 132, but as above men-

tioned, just after the printing impression is made the record is advanced so that it will be beneath the opening 132. Furthermore, the platen is provided with an extension 133 which engages a pin 134 carried by the autographic table 80 so that the table will be elevated with the platen thereby eliminating the tearing of the paper as would be the case if the autographic table remained stationary and the platen was elevated raising the paper. The bevel gear 150 (Figures 7 and 8) is driven by the ratchet 94 and pawl 105 one-tenth of a revolution at each operation of the machine and meshing with the said bevel gear 150 is a bevel gear 151 which is connected to the units wheel 152 of a consecutive counter 153 which is provided with the customary transfer mechanism and tens, hundreds and thousands wheels. All of these wheels are provided with printing characters which are in printing alignment with the characters on the carrier 37 which are in position to print. By this arrangement when the platen 72 is operating a print will be made on the record strip showing the consecutive number, as well as the amount of the purchase and the class of the transaction.

I realize that many changes may be made in the specific construction shown in this application without departing from the spirit thereof. I, therefore, desire to claim my invention broadly, except as I may limit myself in the annexed claims.

I claim:

1. In a register, a platen, a writing table, means whereby said platen and writing table are connected so that when said platen is operated said writing table will be correspondingly moved, and means whereby said platen is operated.

2. In a register, a platen, means whereby said platen is operated, a writing table, and a pin carried by said writing table and overlying a part of said platen so that when said platen is operated the writing table will be correspondingly moved.

3. In a register, a platen, a pivot on which said platen is mounted, means whereby said platen is rotated on said pivot, a writing table, and means whereby said platen and writing table are connected so that when said platen is operated said writing table will be correspondingly moved.

4. In a register, a platen, a writing table, means whereby said platen and writing table are connected so that when said platen is operated said writing table will be correspondingly moved, means whereby said platen is operated, and means to guide the movement of said writing table so that its movement will be rectilinear.

5. In a register, a writing table provided with overturned flanges having slots therein, pins mounted in said slots to guide said table, a platen, means interconnecting said platen and writing table so that when said platen is operated said writing table will be correspondingly moved, and means whereby said platen is operated.

WILLIAM LEONARD PADEN. 65