

E. D'AMORE.
 AUTOMATIC MAGAZINE FIREARM.
 APPLICATION FILED MAR. 6, 1914.

1,112,055.

Patented Sept. 29, 1914.

3 SHEETS-SHEET 1.

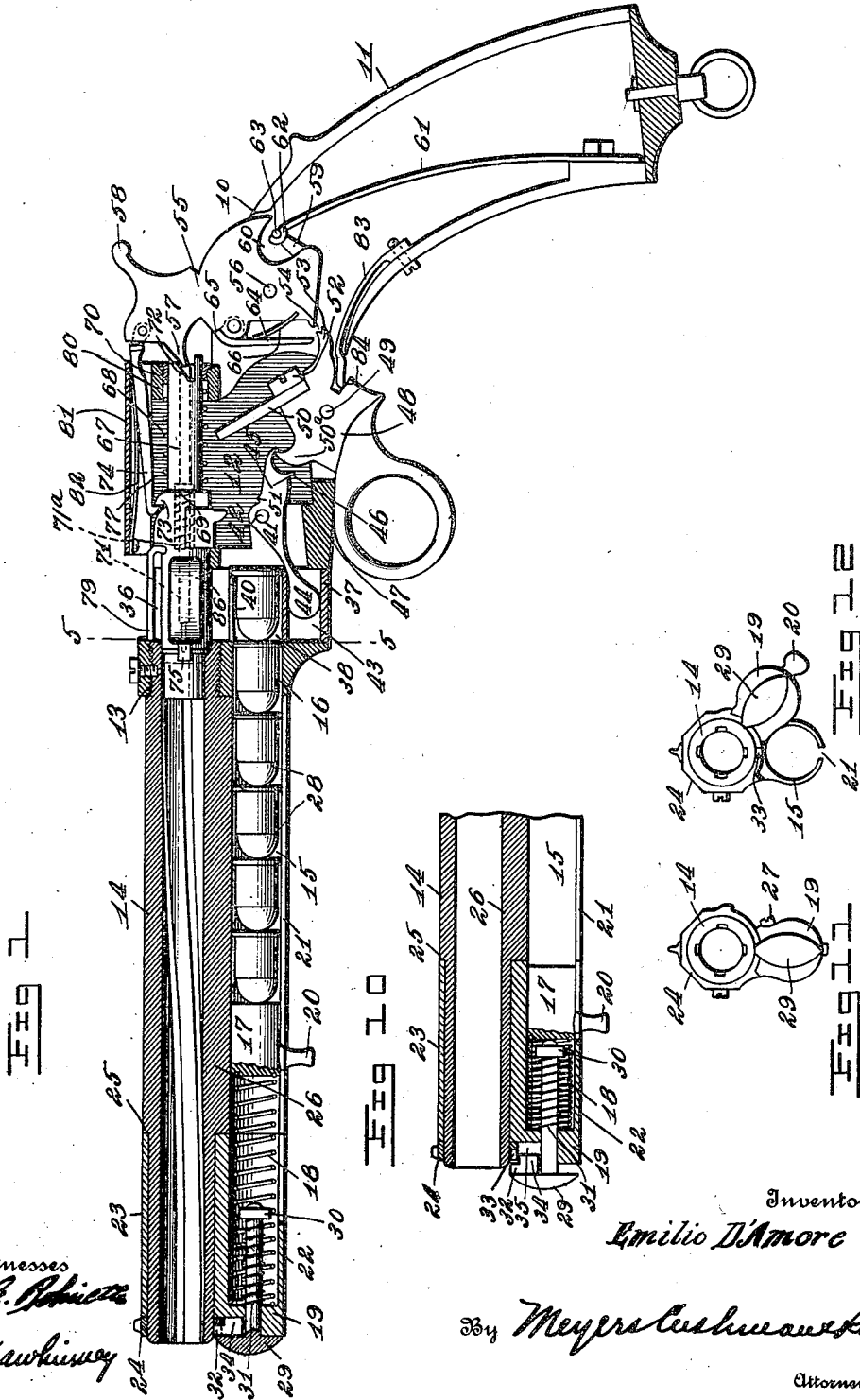

Witnesses
H. C. Roberts
J. M. McKinney

Inventor
Emilio D'Amore

By *Meyers Cushman & Co.*
 Attorney

E. D'AMORE.
 AUTOMATIC MAGAZINE FIREARM.
 APPLICATION FILED MAR. 6, 1914.

1,112,055.

Patented Sept. 29, 1914.

3 SHEETS—SHEET 2.

Fig 2

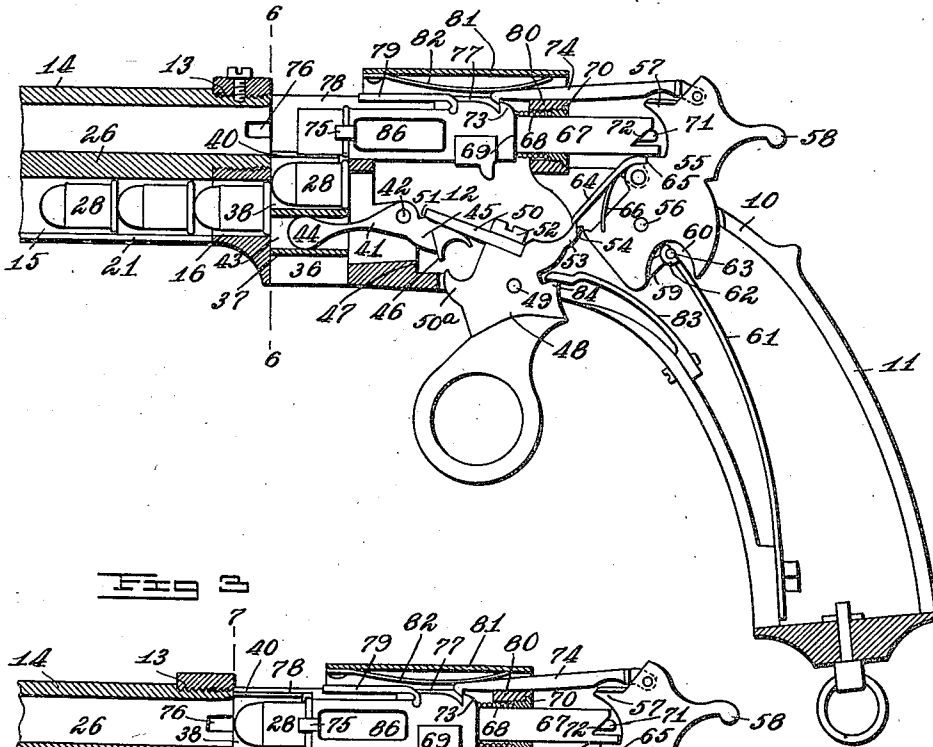
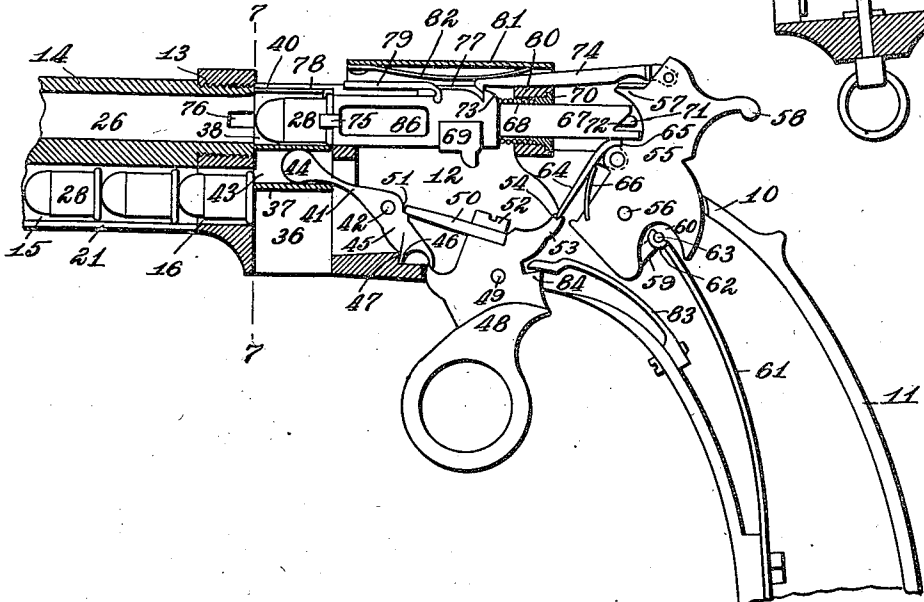

Fig 3



Inventor
 Emilio D'Amore

Witnesses
 H. A. Robinson
 J. T. Mawhinney

By Meyer, Bushman & Co.
 Attorneys

E. D'AMORE.
 AUTOMATIC MAGAZINE FIREARM.
 APPLICATION FILED MAR. 6, 1914.

1,112,055.

Patented Sept. 29, 1914.

3 SHEETS-SHEET 3.

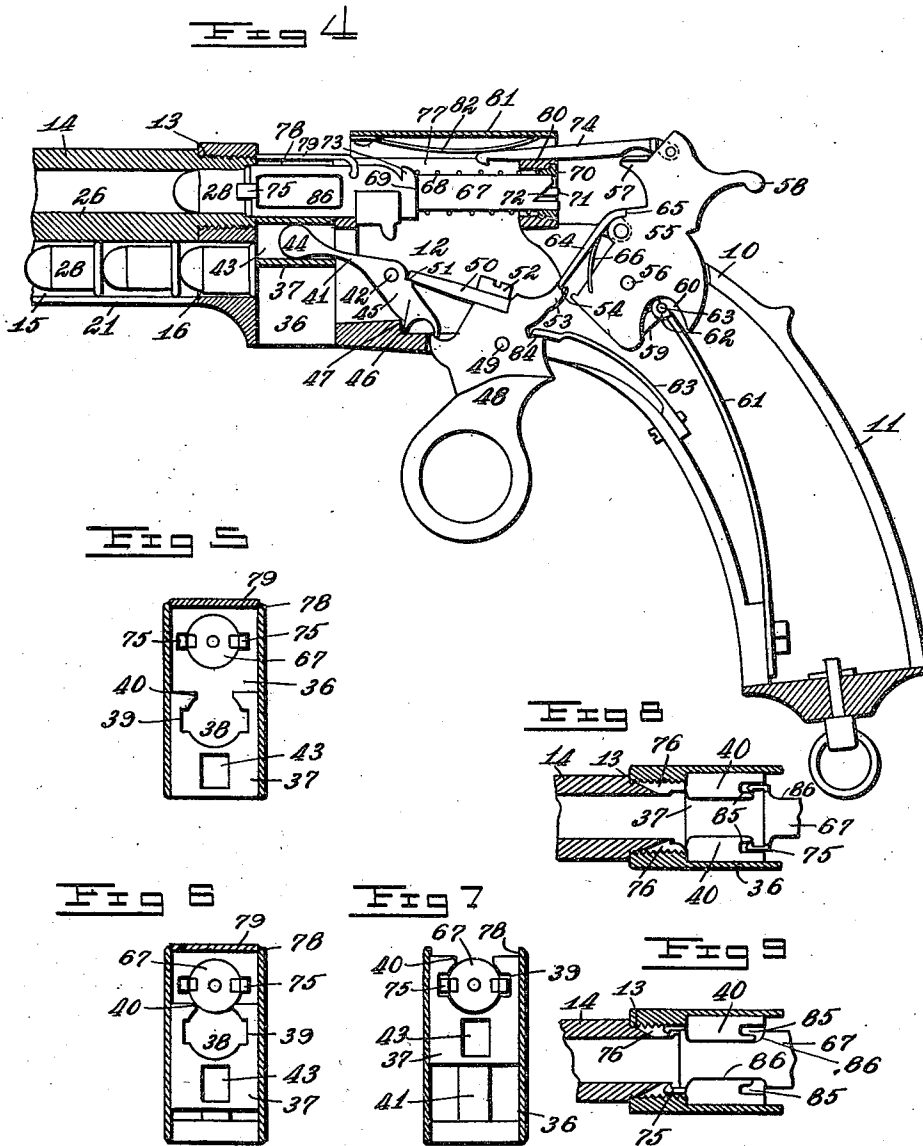

Inventor
 Emilio D'Amore

Witnesses
 H. C. Robinson
 J. T. Mawhinney

By *Meyers & Shuman & Co.*
 Attorney

UNITED STATES PATENT OFFICE.

EMILIO D'AMORE, OF PITTSBURGH, PENNSYLVANIA, ASSIGNOR OF ONE-HALF TO SAMUEL LUCCHINO, TRUSTEE, OF PITTSBURGH, PENNSYLVANIA.

AUTOMATIC MAGAZINE-FIREARM.

1,112,055.

Specification of Letters Patent. Patented Sept. 29, 1914.

Application filed March 8, 1914. Serial No. 822,831.

To all whom it may concern:

Be it known that I, EMILIO D'AMORE, a subject of the Kingdom of Italy, who intends to become a citizen of the United States, residing at Pittston, in the county of Luzerne and State of Pennsylvania, have invented new and useful Improvements in Automatic Magazine-Firearms, of which the following is a specification.

This invention relates to firearms, particularly to automatic magazine firearms, and has for an object to provide a device of this character wherein a number of cartridges are carried in a magazine and are automatically and consecutively fed to the breech of the barrel, and after firing are ejected during and simultaneous with the feeding of the next cartridge.

An important feature of this invention is to provide a firearm of automatic and magazine character which comprises relatively few parts so formed and assembled as to present a substantial and positively operating structure, and a device which may be economically manufactured.

The objects and advantages of this invention will be more particularly pointed out from the following detail description of the present embodiment thereof, the same being illustrated in the accompanying drawings wherein,—

Figure 1 is a longitudinal central section taken vertically through the gun, parts of the mechanism being shown in elevation, and the mechanism being shown in position immediately after firing. Fig. 2 is a similar view with the forward end of the gun broken away, the mechanism being shown in position immediately prior to ejecting a shell. Fig. 3 is a like view showing the parts in position immediately after ejecting a shell. Fig. 4 is a similar view of the parts in position to fire. Fig. 5 is a transverse section on the line 5—5 of Fig. 1. Fig. 6 is a transverse section taken on the line 6—6 of Fig. 2. Fig. 7 is a cross-section taken on the line 7—7 of Fig. 3. Fig. 8 is a detail fragmentary plan view of the carrier and the forward end of the sliding bolt, the breech being shown in section and the parts being shown in the position of Fig. 3. Fig. 9 is a similar view, the parts being shown in the position of Fig. 4. Fig. 10 is a detail

longitudinal sectional view of the forward end of the barrel and the magazine, the latch mechanism being shown. Fig. 11 is an outer end view of the same closed, with the magazine closed. Fig. 12 is a similar view with the magazine open.

Referring to these drawings 10 designates the frame which is suitably formed to provide a stock or handle 11 and a forearm 12. The forearm is provided at its top, and at the forward end thereof, with an internally threaded opening 13 receiving the externally threaded inner end of the barrel 14. Carried beneath the barrel 14 is a magazine 15 in the form of an elongated tube the inner end of which registers with a second opening 16 in the forearm immediately beneath the barrel receiving opening 13. The magazine or tube 15 is provided with a follower 17, urged inwardly toward the forearm by a spring 18, the outer end of which bears against the head or closed outer end 19 of the magazine tube. The follower 17 carries a depending projection or thumb-piece 20, extending through a slot 21 formed longitudinally in the lower side of the magazine tube 15, by means of which the follower may be withdrawn into the tube 15 against the tension of the spring 18 when loading the magazine. The magazine tube 15 is provided with a movable section 22 at its outer end, the same being mounted upon the lower side of a sleeve 23 encircling the outer end of the barrel, the sleeve being held in place upon the barrel by a detachable collar 24 suitably secured to the barrel by set-screws or the like as shown, the sleeve abutting at its inner end against an annular shoulder 25 formed exteriorly upon the barrel. The barrel 14 and the magazine tube are preferably made in one piece and the web 26 joining the same carries a stop screw 27 opposite to the outer end of the main section of the tube 15. The stop screw 27 engages the follower 17 when the same is retracted into the movable section 22 and when the latter is turned out of alignment with the main portion of the magazine. When in this position it will be noted that the cartridges 28 may be inserted in the forward end of the magazine tube 15.

For the purpose of retaining or locking the outer section 22 of the magazine in

alinement with the main section thereof the head 19 is provided with a latch 29 in the form of a rod slidable through the head 19 longitudinally of the section 22, and adapted to be engaged at its inner end by the follower 17 when the same is retracted. The latch 29 is provided with a disk 30 upon its inner end preferably detachably secured to the rod of the latch against which bears one end of a latch spring 31 having its opposite end bearing against the head 19, whereby to normally retract the outer end of the latch 29 within the section 22. The latch 29 is provided with a lateral projection 32 upon its outer extremity which engages in a notch or recess 33 in one side of the collar 24. The projection 32 is adapted to hold or lock the sleeve 23 from turning upon the barrel when the section 22 is in normal position or in alinement with the main section of the magazine tube 15. The lateral projection 32 has an inward extension 34 which moves in a slot 35 registering with the notch 33 when the section 22 is in normal position and which retains the latch 29 from turning in the head 19 when the latch is released from the collar 24.

The forearm 12 of the device is provided with a well 36 opening through the top and bottom of the frame, and also opening into the breech of the barrel 14 and through the lower opening 16 into the magazine 15.

A carrier 37 is located in the well for receiving the cartridges 28 of the magazine and raising them one at a time into alinement with the breech of the barrel. This carrier 37 comprises a block adapted to slide vertically in the well, and is provided in its upper face with a U-shape recess 38 normally registering with the opening 16 and adapted to receive the innermost cartridge from the magazine, the latter being forced into the U-shape recess of the carrier by the spring 18. The opposite walls of the recess 38 have grooves 39 formed therein whereby to provide passages at the opposite sides of the rim of the cartridge 28 for a purpose hereinafter described. The top of the carrier 37 is provided with a pair of inwardly extending flanges 40 adapted to bear against the lower side of a cartridge, when the latter has been withdrawn from the breech of the barrel, for the purpose of ejecting the cartridge through the top of the well 36. The frame 10 is provided in its lower forward end with a lever 41 pivoted upon a transverse pin 42, the forward end of the lever projecting into a pocket 43 in the lower end of the carrier 37. The forward end of the lever 41 is free to move in the pocket 43, and has at its extremity a rounded head 44 bearing against the upper and lower walls of the pocket. The rear or inner end of the lever 41 is relatively short and is provided with a projection 45 ex-

tending downwardly and inwardly from the supporting pin 42. The projection 45 is provided upon its underside with a stop 46 adapted to engage a shoulder 47 on the frame to limit the upward swinging movement of the lever 41.

The carrier operating lever 41 is operated by a trigger 48 pivoted upon a transverse pin 49 in the lower part of the frame. The trigger 48 projects through an elongated opening in the frame 10 and is given any suitable shape whereby the same may be readily engaged by the finger for drawing the trigger. Seated in the upper edge of the trigger 48 is a finger 50 extending forwardly from the trigger and bearing against the upper face of the projection 45, for the purpose of swinging the lever 41 when the trigger is drawn backwardly. A lip 50^a extends forwardly from the trigger beneath the finger 50 and lies beneath the projection 45. To effect the quick operation of the lever 41 to raise the carrier 37, and eject an empty cartridge from the well 36, the projection 45 is provided upon its upper face, and at its inner end, with a transverse rib 51 against which the extremity of the finger 50 engages. The outer side of the rib 51 is beveled, or inclined, and is adapted for engagement with the outer extremity of the finger 50 causing the latter to ride up over the rib and quickly depress the projection 45. The finger 50 is secured to the trigger 48 by a screw 52 or the like. The trigger is also provided with an upwardly and rearwardly extending lug 53, and a groove or depression 54 in its upper end extending transversely of the frame, for a purpose which will hereinafter appear.

In the rear end of the forearm 12 of the frame a hammer 55 is pivoted upon a transverse pin 56, the hammer having the usual forward projection 57 for engagement with the firing-pin and the rearwardly extending thumb-piece 58. A link 59 is hinged to the lower end of the hammer and projects rearwardly into a recess 60 formed in the rear edge of the hammer. The stock or handle portion 11 of the frame carries a back-spring 61 suitably secured in the stock and having its upper and forked end provided with eyes 62 for the reception of studs 63 extending oppositely and laterally from the free end of the link 59. The studs 63 constitute a hinge connection between the upper end of the back-spring 61 and the link. The forward edge of the hammer 55 carries a hinged-leaf 64, the upper end of the leaf being seated in a recess in the edge of the hammer and adapted to be held against the upper wall or shoulder 65 of the recess by a spring 66. The spring 66 has one end inserted in the forward edge of the hammer, and has its free end bearing against the inner side of the leaf 64 near the upper end of

the latter to normally hold the leaf in extended position. The upper end of the leaf engages the shoulder 65 to limit the outward swinging movement of the leaf. The leaf 64 lies in the path of the lug 53 projecting rearwardly from the trigger, the forward movement of the trigger moving the lug 53 downwardly and rearwardly against the leaf 64 and swinging the latter until the lug passes over the lower extremity of the leaf. At this point the leaf springs forwardly and bears against the forward edge of the lug 53.

The forearm of the frame is provided with a longitudinally extending bolt 67 adapted to slide longitudinally in the forearm in line with the barrel. A spring 68, surrounding the bolt 67, engages at its forward end against a shoulder 69 on the bolt and at its rear end against a fixed shoulder 70 on the frame, whereby to normally hold the bolt in extended position toward the breech of the barrel. A firing-pin 71, normally held in retracted position by an encircling spring 71^a, is mounted in the bolt and extends throughout the entire length thereof, the forward end of the firing-pin projecting slightly beyond the forward end of the bolt, while the rear end of the firing-pin projects into a transverse groove 72 formed in the inner end of the bolt and adapted to receive the projection 57 of the hammer when the same is drawn forwardly to strike the firing pin. The bolt is provided in its upper side with a ratchet-tooth 73 extending transversely of the bolt and adapted to receive a pawl 74 hinged to the top of the hammer 55. With each retraction of the hammer the pawl 74 engages the tooth 73 and draws the bolt 67 rearwardly. The forward end of the bolt 67 is provided at its opposite sides with a pair of forwardly extending and laterally offset hooks 75 adapted to extend around the rim of the cartridge shell for the purpose of withdrawing the same from the breech after the discharge of the cartridge. The barrel and the walls of the opening 13 are provided in their opposite sides with grooves 76 which receive the hooks 75 when the same are moved forwardly with the bolt. The bolt 67 is provided with flattened sides 86 extending from the hooks 75 backwardly a distance equal to the length of the well 36 to admit the free downward movement of the carrier 37 after the bolt has carried the cartridge into the breech of the barrel 14. The flanges 40 of the carrier pass down against the flat sides 86 of the bolt when the carrier moves into position to receive a new cartridge from the magazine 15.

The forearm of the frame 10 inclosing the bolt 67 is provided in its upper side with a longitudinal slot 77 through which projects the pawl 74 for engagement with the tooth 73 which extends upwardly from the bolt.

The upper surface of the frame 10 at either side of the slot 77 is flat to provide guides 78 over which moves a slide 79 connected to the bolt 67 and movable therewith. It will be noted that the slide 79 when in its forward position covers the upper end of the well 36 so as to entirely close the same during the firing action. The guides 78 are joined at their rear ends at a point immediately forward of the hammer 55 by a cross-bar 80 over which extends the pawl 74 which is hinged to the hammer 55. The cross-bar 80 is so positioned as to engage the lower side of the pawl 74 when the hammer 55 is retracted to its farther-most position so as to effect the rocking of the pawl 74 on the cross-bar as a fulcrum and raise the outer end of the pawl from engagement with the tooth 73. The cross-bar 80 therefor, serves the purpose of releasing the bolt 67 from the hammer 55 when the latter is moved back into its farthest position ready for firing. A suitable cap or cover 81 is secured upon the frame 10 over the slot 77, the cap 81 having in its underside a suitably formed groove for the reception of the pawl 74, the cap being provided with a spring 82 bearing against the pawl 74 to yieldingly hold the latter down into the slot and against the tooth 73.

The stock 11 carries a leaf spring 83 in the lower side of the frame having a free end offset downwardly through the trigger slot and bearing on a shoulder 84 on the rear edge of the trigger 48, the spring 83 normally holding the lower finger engaging portion of the trigger in a forward position up against the forearm 12 as shown to advantage in Fig. 1. The flanges 40 of the cartridge carrier 37 are provided at their inner ends with oppositely disposed slots or recesses 85 through which is adapted to project the rim of the cartridge and hooks 75 carried by the bolt 67. It will be noted that the flanges 40 are spaced apart at their inner edges to provide an opening through which may pass the flattened forward end of the bolt 67 when the bolt is in its forward position to hold a cartridge in the breech and the carrier is moved down to receive the last succeeding cartridge from the magazine.

In the operation of this improved gun it will be noted from Fig. 1 the position of the mechanism immediately after firing, and wherein the empty shell of the cartridge 28 is shown in the breech of the barrel and ready to be withdrawn and ejected. The trigger 48 is shown as moved forwardly wherein the lip 50^a of the trigger engages beneath the projection 45 of the lever 41 and moves the forward end of the latter down in the well and draws the carrier 37 therewith. As soon as the carrier 37 moves into the position shown in Fig. 1, the spring ac-

tuated follower 17 moves the cartridges longitudinally in the magazine and forces the innermost cartridge into the carrier. The trigger 48 is now drawn backwardly whereby the lug 53 engages the leaf 64 of the hammer and swings the latter backwardly into the position shown in Fig. 2. This movement of the hammer draws the pawl 74 backwardly and, as the pawl engages the tooth 73 in the bolt 67, the bolt is retracted. As the bolt moves backwardly the hooks 75 of the bolt engaging the rim of the empty shell draws the latter out of the breech and into the top of the well. The bolt 67 also draws the slide 79 backwardly beneath the cover or cap 81 thereby opening the top of the well 36. During this operation the finger 50 of the trigger engages the projection 45 of the carrier-lever and moves the projection down a short distance swinging the carrier lever about its supporting pin 42 thereby slightly raising the carrier in to the position to engage the flanges 40 against the underside of the empty shell. This position of the operating mechanism is shown in Fig. 2. Further movement of the trigger 48 forces the finger 50 over the rib 51 on the carrier-lever 41, effecting the quick operation of the carrier lever 41 to raise the carrier 37 in the well, this latter position being shown in Fig. 3 of the drawing. The upward movement of the carrier 37 causes the flanges 40 to eject the empty shell upwardly through the well 36. The new cartridge is now in alinement with the breech and the rim of the cartridge is positioned between the hooks 75 of the bolt 67. It will also be noted from Fig. 3 that the lug 53 engages the lower extremity of the leaf 64, the latter resting in the groove or recess 54 formed in the extremity of the lug 53. The groove 54 serves to hold the leaf 64 in this position. A further slight movement of the trigger 48 raises the leaf 64 slightly and thereby moves the hammer 55 farther backward whereupon the pawl 74 is drawn across the bar 80 and is caused to rock upon the bar to release the outer end of the pawl from the tooth 73. As soon as the tooth 73 is thus released the spring 68 forces the bolt 67 forward and moves the new cartridge into the breech, the hooks of the bolt remaining in contact with the rim of the cartridge and engaging in the grooves 76 in the opposite sides of the barrel. This position is shown to advantage in Fig. 4 wherein the parts are now in position to fire. A slight backward movement of the trigger 48 now releases the lug 53 from the lower extremity of the leaf 64 thus freeing the hammer 55 which is thrust forwardly by the back-spring 61, the hammer striking the firing pin 71 and effecting the discharge of the cartridge. The operating parts are now again in the position as shown in Fig. 1. When it is de-

sired to load the magazine 15 the follower 17 is forced outwardly into the section 22 against the tension of the spring 18 by the thumb-piece 20. As the follower reaches its outermost position it engages the disk 30 which moves the latch 29 outwardly and moves the projection 32 out of the notch 33 in the fixed collar on the barrel. The sleeve 23 is now released and may be swung about the barrel into the position shown in Fig. 12 thereby completely opening the outer end of the magazine. The cartridges may now be inserted in the outer end of the tube 15 when the section 22 is again swung about into normal position and the follower released to bear against the outermost cartridge and force the cartridges toward the forearm.

What is claimed is,—

1. In magazine firearms having a magazine below the barrel, a vertically movable cartridge carrier, a reciprocating breech bolt adapted to feed cartridges from the carrier to the barrel and having extractors for withdrawing the discharged shells therefrom, a tooth on one side of said breech bolt, a spring tending normally to maintain the bolt against the breech of the barrel, a hammer, a pawl pivotally connected at one end to said hammer and adapted to engage by its other end the tooth on the breech bolt to withdraw said bolt when the hammer is retracted, and a tripping means for disengaging the pawl from the tooth to release said bolt.
2. In magazine firearms having a magazine below the barrel, a vertically movable carrier provided with a recess for receiving cartridges from the magazine and conveying them to the breech of the barrel, and flanges above the recess to form a temporary support for extracted shells, a reciprocating breech bolt having extractors adapted to feed cartridges from the carrier into the barrel and withdraw the discharged shells therefrom, a spring tending normally to maintain the bolt against the breech of the barrel, a hammer, a trigger for actuating said hammer, means connected to the hammer for withdrawing the bolt when the hammer is retracted, and means positively operated by the trigger for raising and lowering the cartridge carrier.
3. In magazine firearms having a magazine below the barrel, a vertically movable carrier provided with a recess for receiving cartridges from the magazine and conveying them to the breech of the barrel, and flanges above the recess to form a temporary support for extracted shells, a reciprocating breech bolt having extractors adapted to feed cartridges from the carrier to the barrel and withdraw discharged shells therefrom, a spring tending normally to maintain the bolt against the breech of the barrel, a

hammer, a trigger for actuating said hammer, means pivoted to the hammer and adapted to engage and withdraw said bolt when the hammer is retracted, a lever engaging at one end with said carrier for raising and lowering the same, a finger projecting from the trigger to bear upon the other end of said lever and raise the carrier when the trigger is pulled, and a lip also projecting from the trigger to press upward against the lever and lower the carrier when the trigger is released.

4. In magazine firearms having the magazine below the barrel, a vertically movable carrier provided with a recess for receiving the cartridges from the magazine and conveying them to the breech of the barrel, and flanges above the recess to form a temporary support for extracted shells, a reciprocating breech bolt having extractors adapted to feed cartridges from the carrier to the barrel and withdraw discharged shells therefrom, a spring tending normally to maintain the bolt against the breech of the barrel, a hammer, a hinged leaf or catch on said hammer, means pivoted to said hammer for withdrawing the bolt when the hammer is retracted, a lever engaging at one end with said carrier for raising and lowering the same, and a trigger having a lug for engaging said leaf to retract the hammer, and a finger to operate said lever and raise the carrier when the trigger is pulled, and a lip also to engage said lever and lower the carrier when the trigger is released.

5. In magazine firearms having a magazine below the barrel, a vertically movable carrier provided with a recess for receiving the cartridges from the magazine and conveying them to the breech of the barrel and flanges above the recess to form a temporary support for extracted shells, a reciprocating breech bolt having extractors adapted to feed cartridges from the carrier to the barrel and withdraw discharged shells therefrom depositing them upon the flanges of said carrier, a lever fulcrumed between its ends engaging by one arm with the carrier to positively raise and lower the same and having a rib on the other arm close to said fulcrum, and a trigger provided with a finger to bear first on the free

end of said lever and afterward on the rib thereon to raise said carrier at first slowly and then more quickly. 55

6. In magazine firearms, a cartridge carrier adapted to reciprocate between the magazine and the barrel, a lever fulcrumed between its ends engaging by one arm with said carrier to reciprocate the same and having a rib on the other free arm close to said fulcrum, and a trigger provided with a finger to bear first on the free arm of said lever and afterward on the rib thereon to raise said carrier at first slowly and then more quickly. 60 65

7. In magazine firearms, a cartridge carrier adapted to reciprocate between the magazine and the barrel, a lever fulcrumed between its ends engaging by one arm with said carrier to reciprocate the same and having a rib on the other free arm close to said fulcrum, and a trigger provided with a finger that upon pulling the trigger bears first on the free end of said lever arm and afterward on the rib thereon to raise said carrier at first slowly and then more quickly, and a lip on said trigger that on the return thereof engages the end of said lever to move the same and lower said carrier with a uniform movement. 70 75 80

8. In magazine firearms having a magazine below the barrel, a carrier adapted to reciprocate between the magazine and the barrel for transferring cartridges to said barrel, a rocking lever connected by one arm to said carrier for raising and lowering the same, a rib projecting upwardly from its other arm adjacent the fulcrum of the lever, and a trigger from which a finger projects adapted to press the free arm of said lever when the trigger is pulled and raise said carrier a short distance at relatively slow speed, said finger afterward engaging the rib on said arm and completing the upward movement of the carrier more rapidly. 85 90 95

In testimony whereof I have hereunto set my hand in presence of two subscribing witnesses:

EMILIO D'AMORE.

Witnesses:

GERTRUDE M. STUCKER,
JAS. J. MOWHINNEY.