

AUSTRALIA
Patents Act 1990

651875

**PATENT REQUEST: STANDARD PATENT
and
NOTICE OF ENTITLEMENT**

We, OUTOMEK OY being the person(s) identified below as the Applicant, request the grant of a patent to the person identified below as the Nominated Person, for an invention described in the accompanying standard complete specification.

Full application details follow.

[71] Applicant: OUTOMEK OY
Address: RIIHITONTUNTIE 7 A
02200 ESPOO
FINLAND

[70] Nominated Person: APPLICANT
Address:

[54] Invention Title: FLOTATION MACHINE

[72] Name(s) of actual inventor(s):
Timo UNTAMO; Jouko OLAVI

[74] Address for service in Australia:
GRIFFITH HACK & CO., Patent and Trade Mark Attorneys, 509 St. Kilda
Road, Melbourne, Victoria, AUSTRALIA 3004. Attorney Code: HA

Drawing number recommended to accompany the abstract: 1

BASIC CONVENTION APPLICATION(S) DETAILS

Application Number	Country	Country Code	Date of Application
91 1486	FI		27th March 1991



We, OUTOMEK OY
of, RIIHITONTUNTIE 7 A
 02200 ESPOO
 FINLAND,

being the applicant in respect of Application No. 13811/92, state the following:-

The person(s) nominated for the grant of the patent:

is the assignee of the actual inventor(s).

The person(s) nominated for the grant of the patent:

is the basic the applicant(s).

The basic application(s) listed above is/are the first application(s) made in a Convention country in respect of the invention.

Dated this 26st day of May, 1994.

OUTOMEK OY

GRIFFITH HACK & CO.

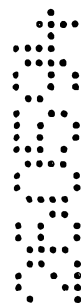
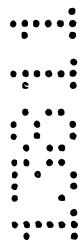



AU9213811

(12) PATENT ABRIDGMENT (11) Document No. AU-B-13811/92
(19) AUSTRALIAN PATENT OFFICE (10) Acceptance No. 651875

- (54) Title
FLOTATION MACHINE
- (51)⁵ International Patent Classification(s)
B03D 001/16 B03D 001/14
- (21) Application No. : 13811/92 (22) Application Date : 26.03.92
- (30) Priority Data
- (31) Number (32) Date (33) Country
911486 27.03.91 FI FINLAND
- (43) Publication Date : 01.10.92
- (44) Publication Date of Accepted Application : 04.08.94
- (71) Applicant(s)
OUTOMEK OY
- (72) Inventor(s)
TIMO UNTAMO; JOUKO OLAVI
- (74) Attorney or Agent
GRIFFITH HACK & CO , GPO Box 1285K, MELBOURNE VIC 3001
- (56) Prior Art Documents
AU 606216 23458/88 B03D 1/22
US 3032199
US 2182442
- (57) Claim

1. A flotation machine for removing mineral particles from a slurry containing such particles, comprising:

a flotation cell having a feed opening for introducing slurry into the cell and a foam outlet for discharging foam from the cell;

a mixing mechanism provided in the flotation cell;

means for supplying air into the cell for forming a foam bed on the slurry contained in the cell; and,

at least one guide member disposed in said cell for reducing, in a region below the foam bed, the free horizontal cross-sectional area of the cell in an upward direction.

AUSTRALIA

65 1875

Patents Act 1990

ORIGINAL

COMPLETE SPECIFICATION

STANDARD PATENT

Invention Title:

FLOTATION MACHINE.

The following statement is a full description of this invention, including the best method of performing it known to me:-

FLOTATION MACHINE

The present invention relates to a flotation machine for flotating minerals or the like from slurries containing these particles, wherein the rising and travelling of the foam from the slurry contained in the flotation machine to the foam bed is controlled.

In flotation machines, the desired valuable mineral particles are put to contact with air bubbles by means of chemicals. The air bubbles rise on the surface of the slurry layer and form a foam layer, the height whereof in free space is normally only 5% of the height between the bottom of the flotation machine and the foam outlet spot. Normally it is attempted to recover the foam contained in the foam layer to outlet ducts attached in the wall of the flotation machine. From the practical point of view, a good result in the recovery of foam to the ducts requires a sufficiently thick foam layer, dependent on the mineral to be flotated and the respective stage in the flotation process. Generally a good result in the foam recovery to the ducts requires a relatively thick foam layer.

In special cells, aiming at good selectivity, where foam washing is applied, the creation of a sufficient foam layer by conventional means is often impossible. The reason for the difficulties in creating thick foam layers is the decomposition of the foam. As the foam decomposes, part of the mineral particles return to the slurry. Now new air bubbles are needed to raise the mineral particles back to the foam layer. This slows down the speed of the flotation process, the air-utilisation efficiency is reduced and the surplus air brings more and more valueless minerals and materials mechanically to the foam.

The rate of the creation and decomposition of the foam are dependent, among others, on the structure of the flotation

machine, on the material under treatment and on the process stage at hand. Several factors can also be distinguished in the foam decomposition process. In most cases, time is one of the most important parameters. In some cases, for instance, a foam layer with the height of 100-200 mm is decomposed in less than ten seconds. The mineral particles that are left from the decomposing foam can return directly to the slurry for instance in the middle part of the flotation machine. If the foam flows very slowly to the outlet ducts, but the creation rate of the foam is high, the decomposing foam may gradually develop so heavy mineral particle accumulations that these accumulations sink back to the slurry through the foam layer. Powerful, disturbing slurry flows under the foam layer may also tear the bottom surface of the foam layer. These foam-breaking processes are intensified along with the growth of flotation machines.

In average, the foam recovery rate K_R on the whole foam surface of the flotation machine is the difference of the average creation rate K_B and the decomposition rate K_D of the foam, i.e.

$$K_R = K_B - K_D \quad (1)$$

when the employed velocity unit is m/s.

In the following survey of magnitudes, it is seen that the quantities K_B and K_D described in formula (1) can be of the same magnitude, in which case it is probable that a remarkable part of the foam is decomposed and the mineral particles return to the slurry. For instance in a flotation cell of one cubic meter, with a free slurry area of 1 m^2 , and an air supply rate of $0.1-0.5 \text{ m}^3/\text{min}$, the foam creation rate K_B is $0.1-0.5 \text{ m}/\text{min}$, which means 17-83 mm per 10 seconds. With several minerals, the foam decomposition rate K_D , which is controversial to the foam creation rate, can be essentially equal.

In large flotation cells, the foam creation rate K_B per area unit grows, because for example in a flotation cell with a volume of 100 m^3 , with an air supply rate of $10\text{-}50 \text{ m}^3/\text{min}$, and a slurry surface of 25 m^2 , the foam creation rate K_B is $0.4\text{-}2.0 \text{ m}/\text{min}$, i.e. roughly four times as high as with the one cubic meter flotation cell of the reference example above.

However, when the size of the flotation machine grows, the slurry surface of the machine extends wide, and simultaneously the distances from the middle part of the flotation machine to the foam outlet ducts increase. Consequently the foam delay time in the middle of the flotation machine is extended more than at the edges.

The changing of the surface flows of the foam is described in the aerating device of the US patent 2,182,442, where the flow of the foam created in the bottom part of the apparatus is controlled by means of a guide member provided in the inner part of the apparatus, so that foam is directed towards those edges of the aerating device where the outlet duct for the foam is located. In the top part of the aerating apparatus of this US patent 2,182,442, essentially at the outlet ducts, there is arranged a guide member, having the shape of a truncated wedge, so that the horizontal bottom of the guide member is located below the foam surface of the aerating device. This guide member directs the created foam towards the outlet ducts provided on two walls of the aerating device, so that the foam is prevented from flowing to around the rotatory axis of the aerating device. Thus the purpose of the guide member is to protect the rotor axis of any unfavourable influences of the foam.

From the FI patent 78,628, there is known a flotation machine where inside the created foam bed, there is installed a downwards narrowing, wedge-like or conical adjusting member to adjust the volume and/or area of the foam bed. This

adjusting member helps make the foam bed thick, and at the same time the foam is directed, when proceeding upwards, towards the walls of the flotation machine and hence towards the outlet ducts provided in the walls.

The wedge-like or conical guide members of the above described patents, located at least partly inside the foam, force the foam to flow towards the outlet ducts of the flotation cell, but they do not essentially change or speed up the creation of the foam nor its process from the slurry to the foam bed. The US patent 4,668,382 describes a flotation method where on the border surface between the slurry and the foam bed in a flotation machine, there is installed a guide member for air bubbles. By means of this member, air bubbles are directed to a foam uptake shaft located centrally with respect to the slurry surface in the flotation machine. The transversal cross-sectional area of the foam uptake shaft is smaller than the free area of the flotation machine. By reducing the area, the foam creation rate is increased. Because the air bubble guide member described in the US patent 4,668,382 is arranged only on the border surface between the slurry and the foam bed, the phenomena taking place in the slurry surface of a flotation machine cannot be essentially controlled by following the method of the US patent 4,668,382.

Hence it is the object of the present invention to achieve an improved flotation machine, more secure in operation and with an essentially large volume, where the drawbacks of the priorart are remarkably decreased by changing and increasing the creation rate of the foam created in the flotation machine as well as its process from the slurry of the flotation machine to the foam bed, and by further increasing the recovery of the foam contained in the foam bed from the flotation machine.



According to the present invention there is provided a flotation machine for removing mineral particles from a slurry containing such particles, comprising:

5 a flotation cell having a feed opening for introducing slurry into the cell and a foam outlet for discharging foam from the cell;

a mixing mechanism provided in the flotation cell;

10 means for supplying air into the cell for forming a foam bed on the slurry contained in the cell; and,

at least one guide member disposed in said cell for reducing, in a region below the foam bed, the free horizontal cross-sectional area of the cell in an upward direction.

15 According to embodiments of the invention, in the slurry chamber of the flotation machine, essentially below the foam bed created in the flotation machine, there is installed at least one adjustable guide member, so that the free surface area of the slurry and foam is decreased while
20 proceeding from bottom to top in the flotation machine. In shape this guide member is advantageously wedge-like, conical, a truncated wedge or a truncated cone, so that the guide member is narrowed either upwardly or downwardly. Advantageously the guide member is arranged so that the
25 restricting effect caused thereby in the slurry chamber of the flotation machine begins at a height which is 30-50% of the distance between the bottom of the flotation machine and the foam outlet spot, ie. the lowest point of the overflow edge, when measured from the bottom of the
30 flotation machine. The guide member is advantageously designed so that its narrowing angle is changed at least once, which means that the guide member is formed of several interconnected and essentially similar elements. The multielement structure of the guide member is advantageous particularly when the guide member is
35



overflow edge, when measured from the bottom of the flotation machine.

The volume flow of the air bubbles containing mineral particles per area unit grows as the free area is reduced, and the thickness of the foam bed grows essentially more rapidly than if the free slurry surface were not reduced. When employing the guide member of the invention, the creation rate of the foam created by the air bubbles containing mineral particles is increased in an advantageous fashion, essentially by following the ratio of the areas, which means that the creation rate in the slurry chamber of the flotation machine, particularly on the border surface between the slurry surface and the foam bed, can in an optimal case grow even 20 times higher, depending on the mineral to be floated.

When using, according to the invention, a guide member in a flotation machine to reduce the free slurry surface, the creation rate of the foam formed by air bubbles containing mineral particles is increased essentially, even many times higher than the decomposition rate of the air bubbles. Thus the delay time of the air bubbles in the foam beds is essentially shortened.

According to the invention, the guide member of the flotation machine of the invention can be installed adjustably, so that the restrictions of the areas, i.e. the reduction of free area, achieved by means of this guide member, can be separately regulated at the element of the guide member provided in the slurry chamber, and at the element of the guide member provided inside the foam bed respectively. The adjustability of the guide member can advantageously be utilized for example when the quality of the ore to be treated in the flotation machine from time to time varies, and different flotation conditions are required. In similar fashion, different adjusting measures of the guide member at different stages of the process can be applied for instance

for flotation machines of one and the same flotation circuit.

The invention is below described in more detail with reference to the appended drawings, where figure 1 illustrates the operating principle of the present invention, and a relevant explanation for the behaviour of foam in the flotation cell, seen as a schematical side-view elevation; figure 2 illustrates a preferred embodiment of the invention as a schematical side-view elevation; and figure 3 illustrates an advantageous shape for the guide member of the invention to be provided in the slurry chamber.

In figure 1, in the slurry chamber 2 of the flotation cell 1, there is arranged a guide member 3 of the invention, which guide member directs the foam created in the bottom part of the cell from the slurry chamber 2 to the foam bed 4 and further, via the foam bed 4 and the overflow edge 24, to the outlet duct 5. The angle of narrowing of the guide member 3 can advantageously be adjusted, so that the member 6 of the guide member 3 located in the slurry chamber, and the member 7 extending to inside the foam bed 4, can be separately adjusted by means of the adjusting members 8 and 9. Likewise, the height of the guide member with respect to the bottom 10 of the flotation cell is adjustable. In figure 1, there is also indicated quantity D_1 describing the whole free surface area of the slurry, and quantity D_2 describing the area of the bottom part of the foam bed 4, reduced by means of the guide member 3. When the quantities mentioned in the description of the prior art above are taken into account, i.e. the foam recovery rate K_R , the foam creation rate K_B and the foam decomposition rate K_D , a connection corresponding to formula (1) can be deduced for these rates. According to ~~the invention~~ ^{this embodiment}, the guide member 3 is used for reducing the area of the foam bed in the ratio



$D_2:D_1$. Because all foam is now discharged through the smaller area, i.e. the area according to D_2 , the formula (1) is changed as follows:

$$K_R = K_B - \frac{D_2}{D_1} K_D \quad (2)$$

Now the average foam recovery rate increases, and respectively less time is left for the decomposition of foam. It is clear that formulas (1) and (2) are reliable with respect to magnitudes only, but they still describe, essentially successfully, the advantage achieved with the guide member of the invention in the discharge of foam from a flotation machine.

In figure 2, in the bottom part of the flotation cell 11 of the flotation machine, there is installed a stator 12 and a rotor 13. In order to rotate the rotor, a motor 14 is arranged above the flotation cell, and this motor is connected to the rotor 13 through a hollow axis 15. The material to be flotated is fed into the flotation cell 11 through the inlet 16. The air needed in the flotation is fed through the conduit 17 to the middle part of the hollow axis 15 and further onto the rotor 13. According to ~~the invention~~ ^{this embodiment} in the slurry chamber 18 formed by the material to be flotated there are arranged guide members 19 comprising downwardly narrowing conical elements, in order to reduce the free surface area of the slurry chamber 18. The guide members 19 are installed so that the conical shape of the members can be adjusted when necessary, either restricted or enlarged, in which case the area ratio D_2/D_1 illustrated in figure 2 can respectively be changed, for instance according to the material to be flotated. The air bubbles created by the rotor 13 and the air fed into the flotation cell 11, which air bubbles carry along particles of the material to be flotated, rise up in the slurry chamber 18 and further through the slurry surface 20 in between the guide members



19 to the foam bed 21 by means of the said guide members 19. Owing to the advantageous change in the velocity, caused by the guide members 19 ~~of the invention~~, the single air bubbles carrying valuable minerals rise essentially rapidly, so that they reach the edge 25 of the outlet ducts 22 and are discharged from the flotation cell 11 to further treatment. The valueless material received in the flotation cell 11 along with the supplied material is removed from the flotation cell 11 through the waste hatch 23.

In figure 3, the flotation cell 31 is provided with a guide member 32, which comprises several essentially interconnected elements 33 and 34, having the shape of a truncated wedge. The lower element 33 in the shape of a truncated wedge serves in the flotation cell 31 as a device for reducing the slurry area. The upper element 34 in the shape of a truncated wedge can advantageously be arranged as a pressure zone for the foam bed 35 formed of the air bubbles obtained from the flotation cell 31, and to this zone there can, when necessary, be connected for instance the washing of the material to be flotated, known from the FI patent 78,628. From the foam pressure zone formed by the element 34, the foam bed 35 is recovered to the outlet ducts 36 provided at the edges 37 of the element 34.



THE CLAIMS DEFINING THE INVENTION ARE AS FOLLOWS:-

1. A flotation machine for removing mineral particles from a slurry containing such particles, comprising:

5 a flotation cell having a feed opening for introducing slurry into the cell and a foam outlet for discharging foam from the cell;

a mixing mechanism provided in the flotation cell;

10 means for supplying air into the cell for forming a foam bed on the slurry contained in the cell; and,

at least one guide member disposed in said cell for reducing, in a region below the foam bed, the free horizontal cross-sectional area of the cell in an upward direction.

20 2. The flotation machine according to claim 1, wherein a lowermost part of the guide member is at a height which is 30-50% of the distance between a bottom of the flotation cell and said foam outlet, when measured from the bottom of the flotation cell.

25 3. The flotation machine according to claim 1 or 2, wherein said guide member can be disposed so that the minimum free horizontal cross-sectional area of the cell is between one half and one twentieth of the maximum free horizontal cross-sectional area of the cell.

30 4. The flotation machine according to claim 1, 2 or 3, wherein the position of a portion of the guide member located below said foam bed can be adjusted for effecting said reduction in free horizontal cross-sectional area of said cell.

5. The flotation machine of any of the preceding claims, wherein said guide member includes a portion



located in said foam bed the position of which can be adjusted for adjusting the height of the foam bed.

5 6. The flotation machine of any of the preceding claims, wherein said guide member is one of a plurality of guide members arranged side by side, and each guide member is adjustable so that the free horizontal cross-sectional area between guide members in the cell can be reduced in a controlled manner in an upward direction.

10 7. The flotation machine of any of the preceding claims, wherein said guide member is conical in shape.

8. The flotation machine of any one of claims 1 to 6, wherein said guide member is wedge-like in shape.

9. The flotation machine of any of the preceding claims, wherein said guide member is downwardly narrowing.

15 10. The flotation machine of any of the preceding claims 1 to 8, wherein said guide member is upwardly narrowing.

20 11. The flotation machine of any of the preceding claims, wherein the guide member is composed of a plurality of interconnected portions, wherein the position of one portion can be adjusted relative to an adjacent portion.

12. A flotation machine substantially as herein described with reference to an as illustrated by any one of the accompanying drawings.

25 Dated this 26th day of May, 1994.

OUTOMECH OY
By its Patent Attorneys:

GRIFFITH HACK & CO.
Fellows Institute of Patent
Attorneys of Australia.



(57) ABSTRACT

The invention relates to a flotation machine for flotating minerals and the like from slurries containing these particles, the said flotation machine comprising a flotation cell and a mixer mechanism provided in the cell, means for introducing air into the cell and means for feeding the material to be flotated into the cell and for removing it therefrom. According to the invention, in the slurry chamber (2, 18) of the flotation machine, essentially below the foam bed (4, 21) created in the flotation machine, there is arranged at least one guide member (3, 19, 32), so that the free area of the flotation machine, essentially at least in the slurry chamber (2, 18) below the foam bed (4, 21) can be reduced when proceeding upwards.



13811/92

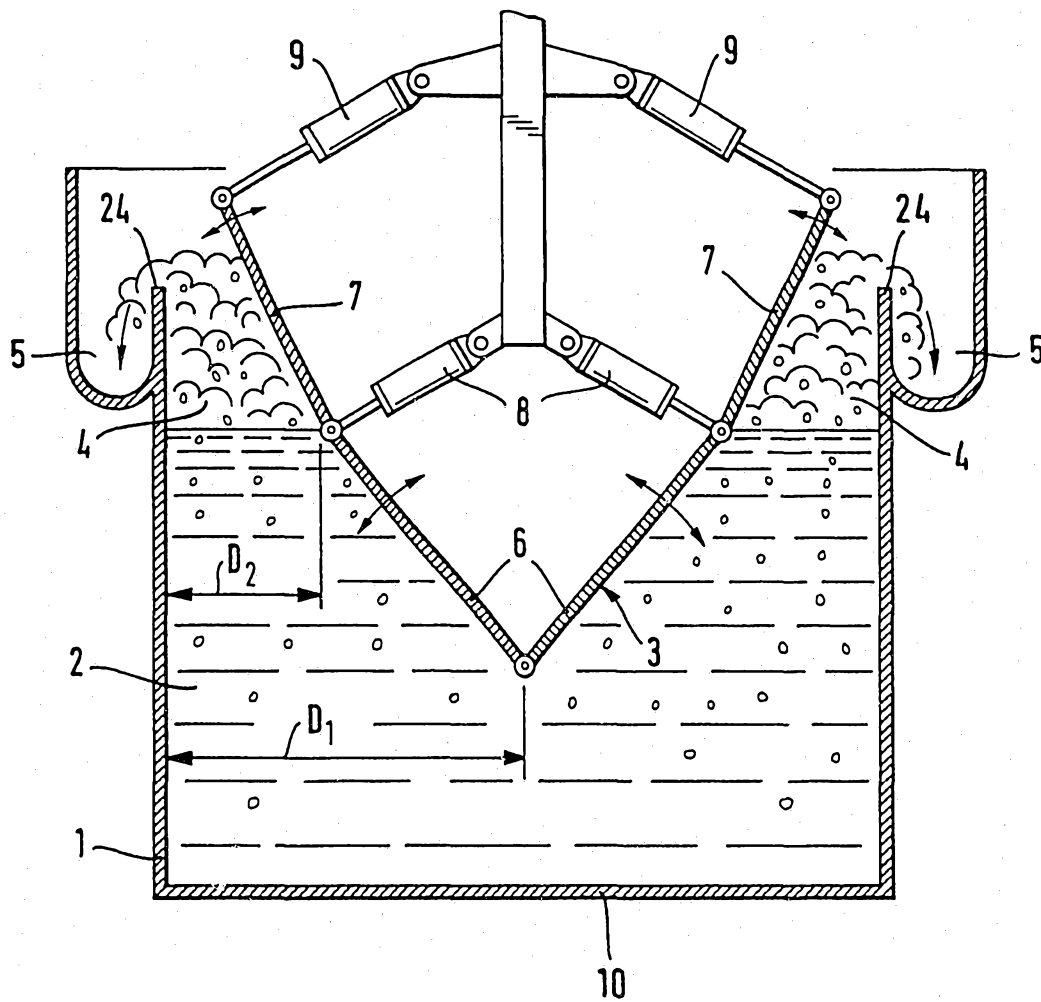

Fig. 1

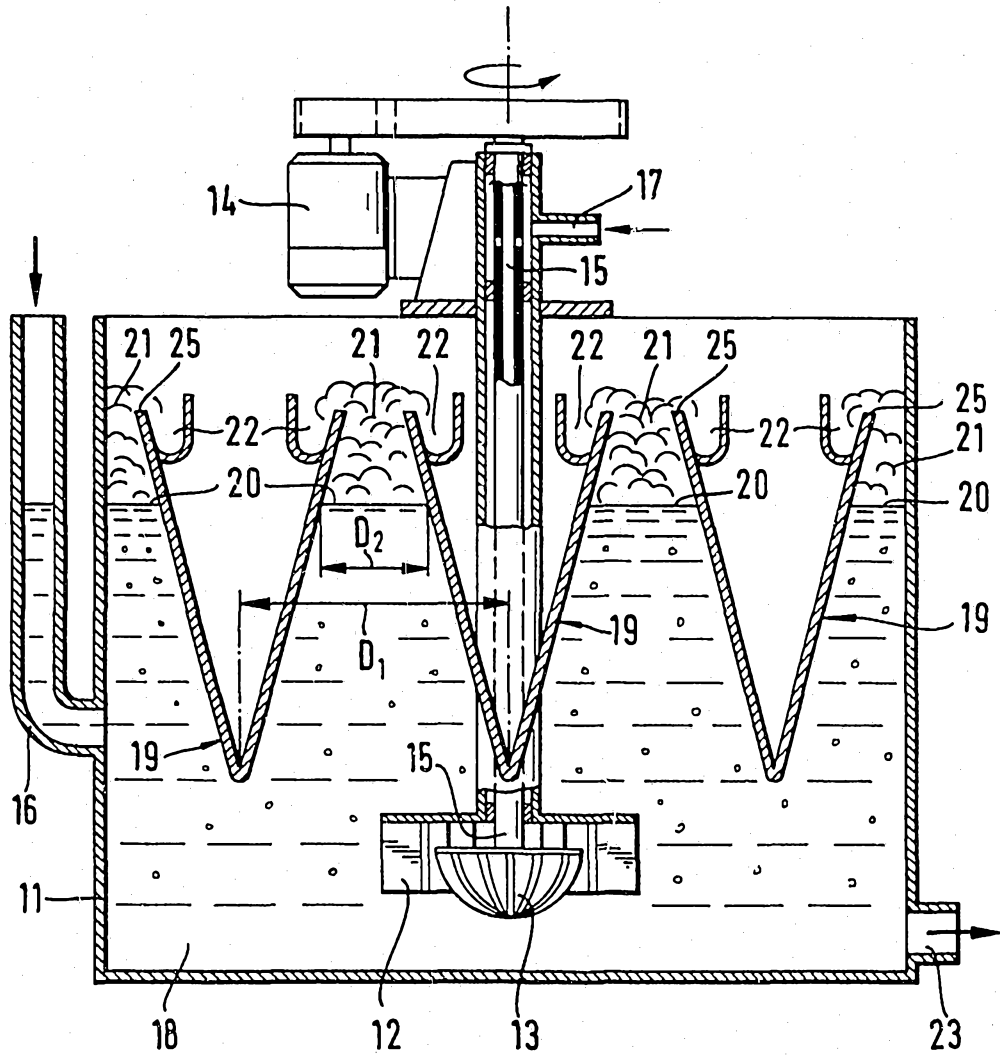

Fig. 2

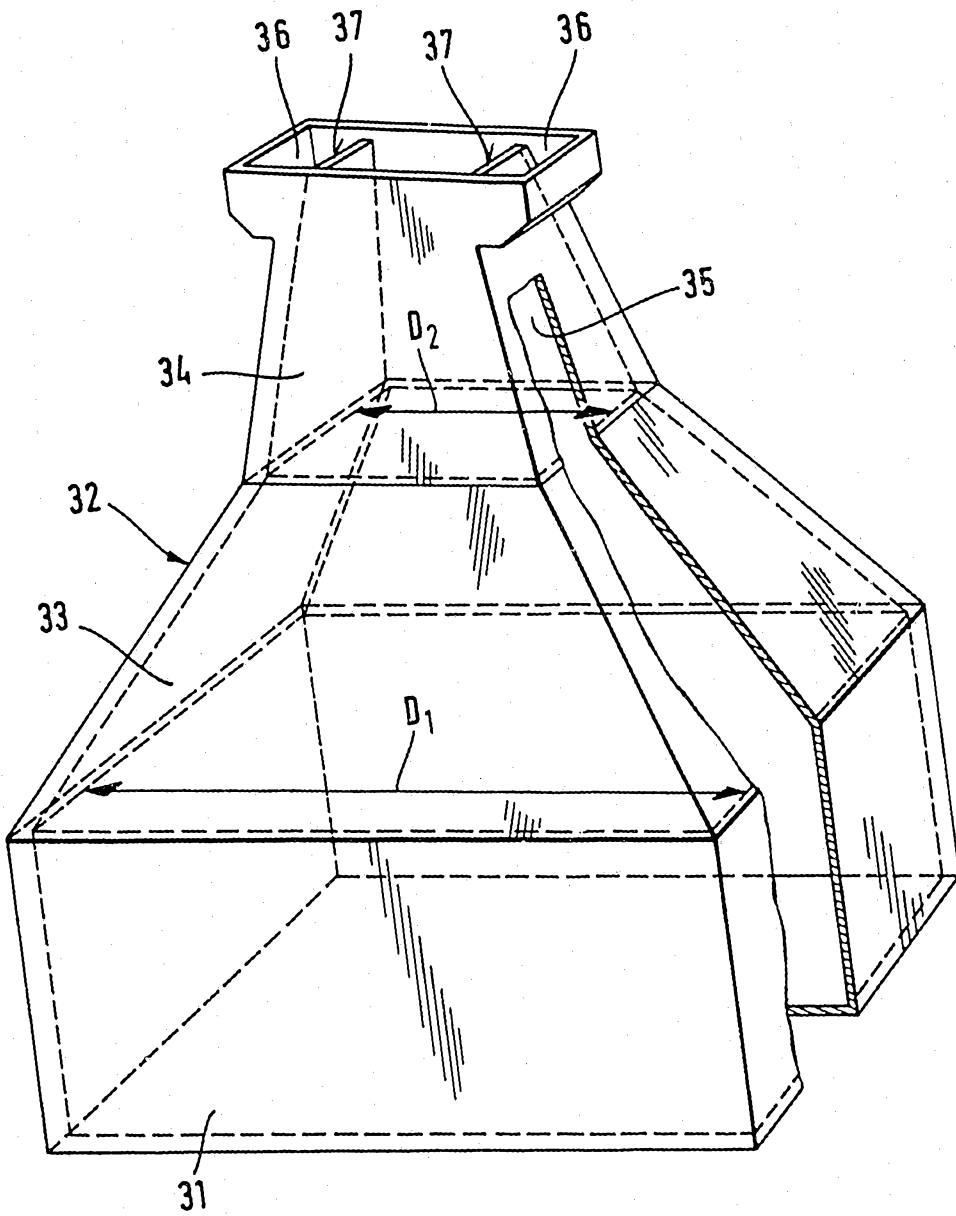

Fig. 3