



INTERNATIONAL APPLICATION PUBLISHED UNDER THE PATENT COOPERATION TREATY (PCT)

<p>(51) International Patent Classification ⁵ : E21B 23/00, 47/00</p>	A1	<p>(11) International Publication Number: WO 93/18277 (43) International Publication Date: 16 September 1993 (16.09.93)</p>
<p>(21) International Application Number: PCT/DK93/00092 (22) International Filing Date: 12 March 1993 (12.03.93) (30) Priority data: 0341/92 13 March 1992 (13.03.92) DK (71) Applicant (for all designated States except US): HTC A/S [DK/DK]; Granskoven 10, DK-2600 Glostrup (DK). (72) Inventor; and (75) Inventor/Applicant (for US only): HALLUNDBÆK, Jørgen [DK/DK]; Lyngby Hovedgade 76, DK-2800 Lyngby (DK). (74) Agent: HOFMAN-BANG & BOUTARD A/S; Adelgade 15, DK-1304 Copenhagen K (DK).</p>		<p>(81) Designated States: AT, AU, BB, BG, BR, CA, CH, CZ, DE, DK, ES, FI, GB, HU, JP, KP, KR, KZ, LK, LU, MG, MN, MW, NL, NO, NZ, PL, PT, RO, RU, SD, SE, SK, UA, US, VN, European patent (AT, BE, CH, DE, DK, ES, FR, GB, GR, IE, IT, LU, MC, NL, PT, SE), OAPI patent (BF, BJ, CF, CG, CI, CM, GA, GN, ML, MR, SN, TD, TG).</p> <p>Published <i>With international search report.</i> <i>In English translation (filed in Danish).</i></p>
<p>(54) Title: A TRACTOR FOR ADVANCING PROCESSING AND MEASURING EQUIPMENT IN A BOREHOLE</p>		
<p>(57) Abstract</p> <p>A hydraulically driven tractor (4) serves to advance processing and/or measuring equipment (5) in subterranean formation (1). The tractor (4) comprises a section (12) which is filled with hydraulic oil and contains a hydraulic pump (16) for the hydraulic system (17) of the tractor, an electric motor (19) for operating the pump (16) and a battery (20) for energizing the motor (19). The motor (19) is an open AC motor, and a converter (28) for converting the DC current from the battery to AC current is inserted between the motor and the battery (20). The battery (20) and the converter (28) are incorporated in an air-filled pressure container (31). The tractor is suitable for working under the extremely high temperatures and pressures which prevail in a deep borehole. Considerable economic and time benefits are obtained by using the tractor instead of a drill string for advancing the measuring tools in the borehole.</p>		

FOR THE PURPOSES OF INFORMATION ONLY

Codes used to identify States party to the PCT on the front pages of pamphlets publishing international applications under the PCT.

AT	Austria	FR	France	MR	Mauritania
AU	Australia	GA	Gabon	MW	Malawi
BB	Barbados	GB	United Kingdom	NL	Netherlands
BE	Belgium	GN	Guinea	NO	Norway
BF	Burkina Faso	GR	Greece	NZ	New Zealand
BG	Bulgaria	HU	Hungary	PL	Poland
BJ	Benin	IE	Ireland	PT	Portugal
BR	Brazil	IT	Italy	RO	Romania
CA	Canada	JP	Japan	RU	Russian Federation
CF	Central African Republic	KP	Democratic People's Republic of Korea	SD	Sudan
CG	Congo	KR	Republic of Korea	SE	Sweden
CH	Switzerland	KZ	Kazakhstan	SK	Slovak Republic
CI	Côte d'Ivoire	LJ	Liechtenstein	SN	Senegal
CM	Cameroon	LK	Sri Lanka	SU	Soviet Union
CS	Czechoslovakia	LU	Luxembourg	TD	Chad
CZ	Czech Republic	MC	Monaco	TG	Togo
DE	Germany	MG	Madagascar	UA	Ukraine
DK	Denmark	MI	Mali	US	United States of America
ES	Spain	MN	Mongolia	VN	Viet Nam
FI	Finland				

A tractor for advancing processing and measuring equipment
in a borehole

5 The invention concerns a hydraulically driven tractor for
advancing processing and/or measuring equipment in a pre-
drilled hole in a subterranean formation, comprising a
section filled with hydraulic oil and containing a
hydraulic pump for the hydraulic system of the tractor,
10 an electric motor for operating the pump and a battery for
energizing the motor.

Boreholes for exploitation of oil and gas frequently
extend many kilometers into the underground to reach and
penetrate the oil and gas bearing strata. Information for
15 the planning and control of the production must be ob-
tained from these not very accessible regions deep below
the surface where extremely high temperatures and pres-
sures prevail. This information is i.a. to tell about the
type of the formation, its porosity and permeability as
20 well as content of oil, gas and water, and also various
tasks may have to be performed, such as perforation of an
existing casing and operation of valves in it.

With this end in view an abundant range of equipment has
25 been developed in the course of time in the form of
measuring tools and instruments, which are capable of
resisting the high temperatures and pressures in a deep
borehole, and which moreover have a configuration such
that they can pass through it. Generally, a plurality of
30 interconnected tools having a rather considerable overall
length of frequently about 20 to 30 meters and a weight of
e.g. 1500 kg are simultaneously passed down into the
borehole. Equipment of this type can readily be lowered in
a wire line solely under the action of gravity, when the
35 borehole extends vertically or with a minor inclination

- 2 -

with respect to the vertical, but in case of greater inclinations above about 60° the equipment settles on the bottom of the borehole. This situation occurs frequently, since many of the interesting strikes are present
5 precisely in the more or less horizontally extending strata in the underground.

A known method of solving this problem comprises the use of a thin-walled steel pipe wound on a drum and pressurized to obtain a sufficiently great stiffness. By successively unwinding this steel pipe from the drum and subjecting it to a pressure force equipment of the above-mentioned type can be pushed a distance of between 500 and 900 meters into a horizontal borehole.
10

15 However, with the advanced technology used today the boreholes are very frequently drilled with a considerably greater length. In these cases it is common to use the actual drill string for advancing the equipment in the borehole. The equipment is then threaded on to the end of the drill pipes, following which the drill string is assembled. The electric wires, which connect the instruments with the station on the surface, extend on the outer side of the drill string and are run into the various
20 instruments via inserted intermediate pipes in the drill string. The equipment can be moved relatively far into a horizontal borehole by means of this method, but on the other hand the process is cumbersome and slow. With a borehole having an overall length of 5000 meters, of which
25 half extends with an inclination of above 60° with respect to the vertical, the time spent will thus typically be about 24 hours.
30

A natural solution might comprise using a self-propelling tractor of the type which is described in the Applicant's international patent application PCT/DK89/00213, for pull-
35

- 3 -

ing or pushing the measuring equipment through the borehole. This tractor is intended to exert the necessary pressure on a drill bit while pulling the drill string after it in the drilled hole, and it thus has a considerable traction force. The wheels of the tractor are pressed against the wall of the borehole and are caused to rotate by means of a hydraulic system having a hydraulic pump, which is normally driven by a mud motor when the tractor is used in connection with a drilling operation. If the tractor is to be used solely for advancing measuring tools in the borehole, no drilling mud is available for driving a mud motor, and instead this may expediently be replaced by an electric motor.

The power supply for such an electric motor may e.g. be obtained from the surface via a cable which, however, is usually not capable of transferring a power greater than about 500 watts, partly because the cable is wound on a drum, partly because it offers great resistance owing to its length. In case of long boreholes a considerable voltage drop must thus be expected along the cable, so that an applied voltage of 600 volts at the surface may be reduced to 150 volts down in the borehole where the tools are present. To this should be added that owing to the safety of the personnel it is a requirement that only relatively small voltages and current intensities are used.

A solution to these problems might be that the tractor brought its own power supply in the form of a battery which, however, cannot, or only with great difficulty, operate directly under the extremely severe working conditions in the borehole, and a battery supplying DC is not useful as a power source for an electric motor which is to be capable of working in the same difficult environment. The new and unique features of the invention remedying

- 4 -

these drawbacks are that the motor is an open AC motor,
that a converter is inserted between the motor and the
battery for converting the DC of the battery to AC, and
that the battery and the converter are incorporated in an
5 air-filled pressure container.

Furthermore, a control relay may advantageously be incor-
porated in the pressure container to start and stop the
motor via signals through the cable from the surface, as
10 desired.

The invention will be explained more fully by the follow-
ing description of an embodiment, which just serves as an
example, with reference to the drawing, in which

15 fig. 1 schematically shows a fraction of a vertical
section through a subterranean formation with a borehole
in which a self-propelling tractor pulls a number of
measuring tools,

20 fig. 2 schematically shows the tractor of fig. 1 on an
enlarged scale, and

25 fig. 3 shows a fraction of a section for the tractor of
figs. 1 and 2 with its power assembly.

Fig. 1 shows a subterranean formation 1 with a borehole 2,
which initially extends vertically down into the formation
and then through a bend horizontally. A tractor 4 drives
30 in the borehole, pulling a trail 5 of three hooked-up
measuring tools. A tower 6 with a drum 7 is mounted on the
surface 3 and on the borehole 2, a wireline 8, whose
lowermost end is connected with the measuring tool trail
5, being wound on said drum. The wireline 8 is in turn
35 connected via an electric connection 9 with a measuring
station, which, in this case, is in the form of a vehicle

- 5 -

containing the necessary means for recording and interpreting the measurement signals received from the borehole.

5 Fig. 2 is an enlarged view of the actual tractor 4 with a portion of the front part of the trail 5 being indicated in dashed lines. The tractor 4 substantially consists of a front traction section 11 and a rear power section 12. The traction section 11 may e.g. be arranged like the apparatus described in the Applicant's previously mentioned
10 international patent application PCT/DK89/00213, it being observed that the invention can be used in connection with any apparatus of this type. The traction section 11 is self-propelling and has wheels 13 capable of running on
15 the wall 14 of the borehole. The wheels are driven by a hydraulic system which likewise keeps the wheels pressed against the wall of the borehole, so that they can transfer the necessary traction force to it.

20 Fig. 3 shows an enlarged section through the power section 12 of the tractor. Outwardly this has a wall 15 and is filled with hydraulic oil under pressure, which may e.g. be 1300 bars in deep boreholes. A compensator (not shown), which is of a known type and will therefore not be
25 mentioned more fully here, is provided in the power section to equalize the pressure with respect to the surroundings. The power section comprises a hydraulic pump 16 inserted with hydraulic pipes 17 into the hydraulic circuit of the traction section 11 to the wheels 13. The
30 hydraulic pump 16 is driven via a shaft 18 by an electric motor 19. A battery 20 serves to energize the motor 19. The power section is connected with the measuring tools and measuring station on the surface via a wire 21 having the necessary electric cables 22, which are run into a
35 cable distributor 23 and from this via other electric cables 24 to optional measuring tools arranged in front of

- 6 -

the tractor. The battery is connected by electric cables 25, 26 and 27, respectively, to the electric motor 19 via an electric converter 28 and a control relay 29, which is in turn connected with the measuring station 10 on the surface via a control line 30, the cable distributor 23 and the electric cables 22.

As mentioned, the power section 12 is filled with hydraulic oil under a very high pressure, which may be up to 1300 bars, and it will therefore not be expedient to use a fully encapsulated electric motor whose shaft lead-in will have difficulty in maintaining a tight seal against the huge pressure difference. The electric motor 19 is therefore of an open design and interiorly completely filled with hydraulic oil. A DC motor is not suitable for working with the commutator thus immersed in oil, and instead an AC motor is used without a commutator. The DC current from the battery 20 is therefore converted to AC current in the converter 28 before being fed to the electric motor 19.

The battery 20, the converter 28 and the control relay 29 are moreover encapsulated in an air-filled pressure container 31, since these electric components cannot stand being exposed in the hydraulic oil because of i.a. the high pressure in it.

Just a start and stop signal is required for controlling the tractor, applied to the control relay 29 from the measuring station on the surface via the wireline 21 and the control line 30. Another way of controlling the tractor is to incorporate a timer (not shown) in it for starting the tractor after e.g. half an hour and stopping it again when a touch sensor (not shown) engages the end of the hole.

35

- 7 -

A tractor for an 8 1/2" borehole may typically have the following specifications:

	Max outside diameter	149 mm
5	Nominal diameter	140 mm
	Length	3-4 m
	Weight max	200 kg
	Weight incl. buoyancy max	100 kg
	Power requirement max	5.0 kW
10	Power requirement average	1.2 kW
	Battery amount minimum	5 kWh
	Speed constant	1000 m/h
	Force forward max	15 kN
	Wash outs	280 mm
15	Hydrostatic pressure max	1300 bars
	Temperature max	150°C
	Tensile strength	30 kN

The above-mentioned tractor will be capable of pulling 20 to 30 meters of measuring tools as well as a minimum of 3000 of wireline having a total weight of about 1500 kg in a horizontal borehole.

To ensure undisturbed operation of the wireline drum on the surface it will expedient that the tractor drives forwardly in the borehole at a constant speed, irrespective of the load, so that the wireline correspondingly runs in the hole at a constant rate over the distance in which the tractor is active. Normal down rate of the standard measuring tools is about 3000 m/h, and a normal retraction rate with the wireline is about 600 m/h. The speed of the tractor is expediently fixed at 1000 m/h to limit the power requirement.

In the previously mentioned borehole having an overall depth of 5000 meters, of which half had an inclination of

- 8 -

above 60°, the time it took the drill string to advance
the measuring tools was about 24 hours. Instead, using the
tractor of the invention with the above-mentioned specifi-
cations this time can typically be reduced to 8 hours,
5 thus providing a time saving of about 16 hours.

10

15

20

25

30

35

P a t e n t C l a i m s :

- 5 1. A hydraulically driven tractor for advancing process-
ing and/or measuring equipment in a pre-drilled hole in a
subterranean formation, comprising a section filled with
hydraulic oil and containing a hydraulic pump for the
hydraulic system of the tractor, an electric motor for
operating said pump and a battery for energizing the
10 motor, c h a r a c t e r i z e d in that the motor is an
open AC motor, that a converter for converting the current
to AC current is inserted between the motor and the
battery, and that the battery and the converter are
incorporated in an air-filled pressure container.
- 15 2. A tractor according to claim 1, c h a r a c t e r -
i z e d in that the pressure container moreover incor-
porates a control relay.
- 20
- 25
- 30
- 35

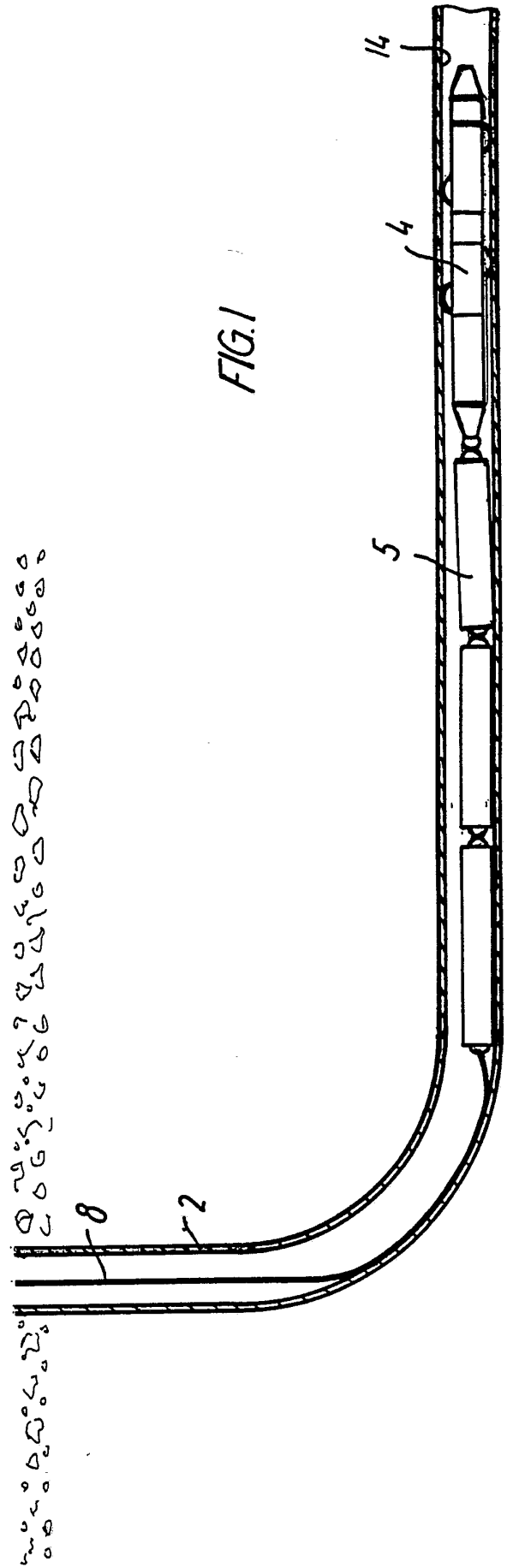
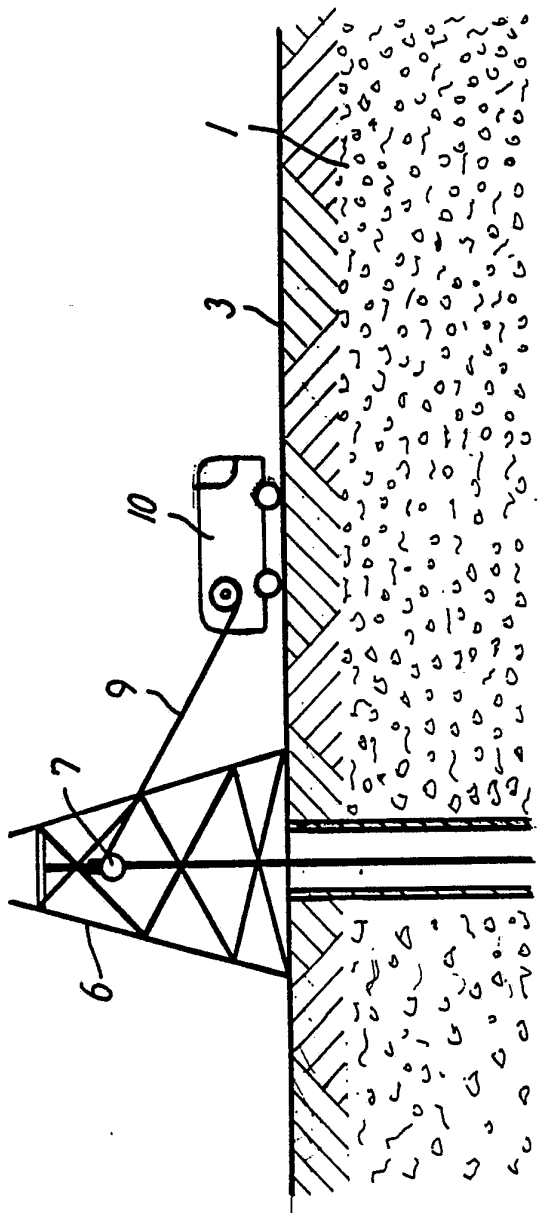

FIG. 1

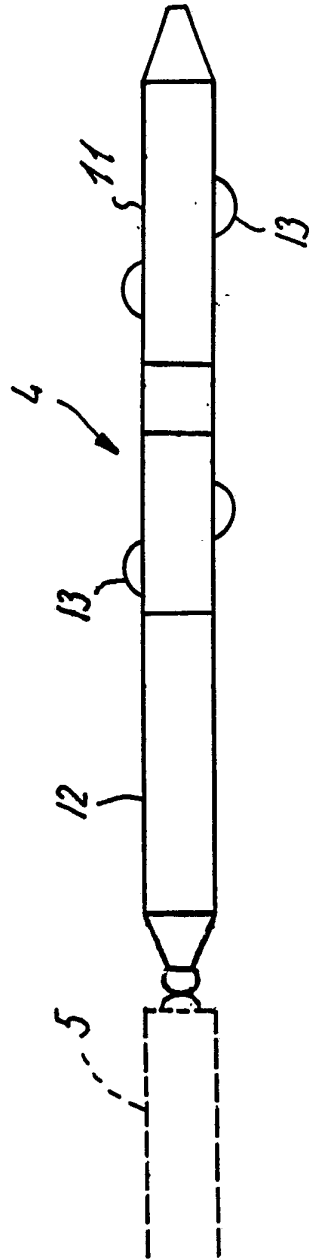

FIG. 2

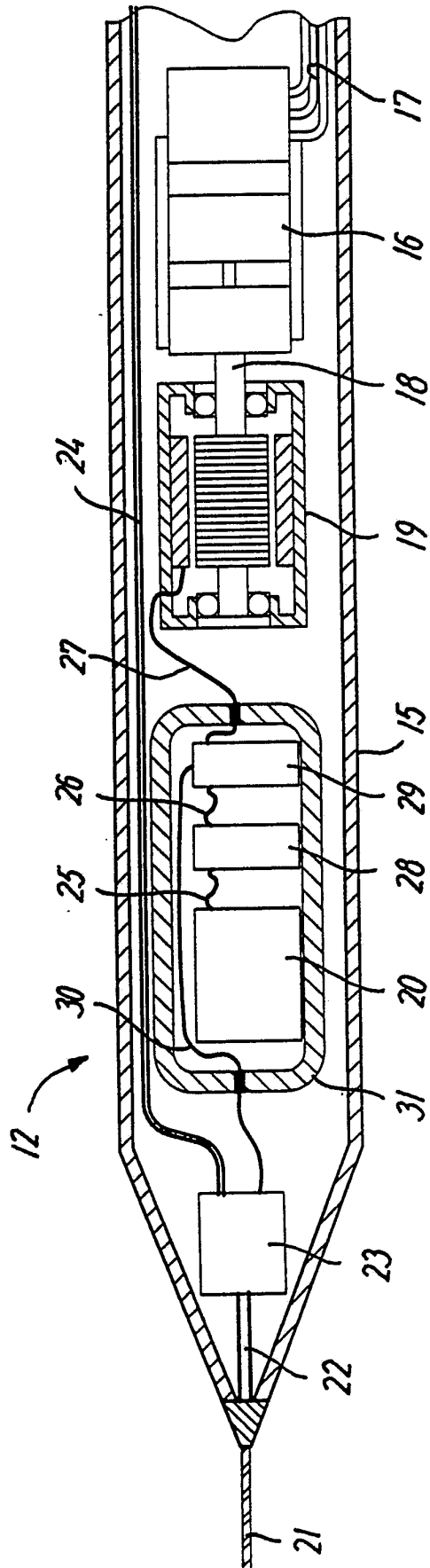

FIG. 3

INTERNATIONAL SEARCH REPORT

International application No.

PCT/DK 93/00092

A. CLASSIFICATION OF SUBJECT MATTER		
IPC5: E21B 23/00, E21B 47/00 According to International Patent Classification (IPC) or to both national classification and IPC		
B. FIELDS SEARCHED		
Minimum documentation searched (classification system followed by classification symbols)		
IPC5: E21B		
Documentation searched other than minimum documentation to the extent that such documents are included in the fields searched		
SE,DK,FI,NO classes as above		
Electronic data base consulted during the international search (name of data base and, where practicable, search terms used)		
C. DOCUMENTS CONSIDERED TO BE RELEVANT		
Category*	Citation of document, with indication, where appropriate, of the relevant passages	Relevant to claim No.
A	DK, B, 137935 (MOBIL OIL CORPORATION), 5 June 1978 (05.06.78), page 7, second paragraph --	1-2
A	US, A, 3433986 (A. ARUTUNOFF), 18 March 1969 (18.03.69), column 1, line 21 - line 40 --	1-2
A	US, A, 4833354 (C.S. MILLER), 23 May 1989 (23.05.89), column 2, line 51 - line 66 --	1-2
A	US, A, 4763259 (L.C. DELATORRE ET AL), 9 August 1988 (09.08.88), column 2, line 61 - column 3, line 3 --	1-2
<input checked="" type="checkbox"/> Further documents are listed in the continuation of Box C. <input checked="" type="checkbox"/> See patent family annex.		
<p>* Special categories of cited documents:</p> <p>"A" document defining the general state of the art which is not considered to be of particular relevance</p> <p>"E" earlier document but published on or after the international filing date</p> <p>"L" document which may throw doubts on priority claim(s) or which is cited to establish the publication date of another citation or other special reason (as specified)</p> <p>"O" document referring to an oral disclosure, use, exhibition or other means</p> <p>"P" document published prior to the international filing date but later than the priority date claimed</p> <p>"T" later document published after the international filing date or priority date and not in conflict with the application but cited to understand the principle or theory underlying the invention</p> <p>"X" document of particular relevance: the claimed invention cannot be considered novel or cannot be considered to involve an inventive step when the document is taken alone</p> <p>"Y" document of particular relevance: the claimed invention cannot be considered to involve an inventive step when the document is combined with one or more other such documents, such combination being obvious to a person skilled in the art</p> <p>"&" document member of the same patent family</p>		
Date of the actual completion of the international search		Date of mailing of the international search report
14 June 1993		15 -06- 1993
Name and mailing address of the ISA/ Swedish Patent Office Box 5055, S-102 42 STOCKHOLM Facsimile No. +46 8 666 02 86		Authorized officer Christer Bäcknert Telephone No. +46 8 782 25 00

INTERNATIONAL SEARCH REPORT

International application No.

PCT/DK 93/00092

C (Continuation). DOCUMENTS CONSIDERED TO BE RELEVANT

Category*	Citation of document, with indication, where appropriate, of the relevant passages	Relevant to claim No.
A	US, A, 4499955 (F.L. CAMPBELL ET AL), 19 February 1985 (19.02.85), column 6, line 21 - line 45 ----- -----	1-2

INTERNATIONAL SEARCH REPORT
Information on patent family members

28/05/93

International application No.
PCT/DK 93/00092

Patent document cited in search report	Publication date	Patent family member(s)	Publication date
DK-B- 137935	05/06/78	NONE	
US-A- 3433986	18/03/69	NONE	
US-A- 4833354	23/05/89	CA-A- 1312109 DE-A,C- 3916253 FR-A- 2632787 GB-A,B- 2220527 JP-A- 2084034 NL-A- 8901351	29/12/92 14/12/89 15/12/89 10/01/90 26/03/90 02/01/90
US-A- 4763259	09/08/88	NONE	
US-A- 4499955	19/02/85	NONE	