

10- 10a-
 10b- 12-
 14- 14a-
 14b- 1 14c-
 14d- 16- 가
 16a- 2

가 , 가
 (10) 1 가
 (12)

(12) (10)가
 (12a) (12a) (H) (12a) 1,2,3,4,5
 1,2,3,4,5,R
 (10) (12)

(12a) (12) (12a) 가
 (10)가

가 가

2 , 4 2 가 , 3 2
 (14) , (14) 가 (16)
 (14) (10) (10b) (H) 1,2,3,4,5,R
) (14a) 가

H) (10b) (14) (H) 5 (14a) (14c) (14d) (14c) (14d) 가 1 (14b) (10b) (14a) (10b) 가 (14c) (10b) (14a) (H) 가 5 6 (14d) 가 가 4 (10a) / (14b) 2 (16a) 1 (14b) (10a) / (1,2,3,4,5,R) 가 (16) (10) (10a) 1 (14b) 가 4 (12) (12a) 2 (16a) (1,2,3,4,5,R) 2 (16a)) 2 (16a) 2 (16a) 1 (14b) (10a) / (1,2,3,4,5,R) 3 가 (16) 2 (16a) (10)가 (12) 가 (12a) (10a) 1 (14b) 가 (12a) 2 (16a) (14d) 1 (14b) (14d) (14c)가 () (14c) (10b) (14a) (10b) (14a) (10b) (10)가 1 (14b) 2 (16a) (10b) (14a) (14d) (20) (20) 7 (20) (20b) (12) (24)가 (P,R,N,D,2,L) (24) (24a) 1 (24) 가 1 (24b) 5,6 (20a) (12) 1 (2 4b) 2 (26a) 가 (26)가 (20)가 (P,R,N,D,2,L) 2 1 (10b) (14) (10) 가

(57)

1.

(10b) 가 (14a), (14a)
 (10b) 가 (14c), (14c) (10b)
 가 (14d) 가 (14c) 가 1 (14a)
 (14) , (14b) 가 (12) (12a) 2
 (16a) 1 (14b) 가 (16) .
 2.
 3.
 1
 1 (14b) (10a) /
 4.
 5.
 1
 2 (16a) (10a) 1 (14b) (
 12a) 6.
 1
 4a) , (24) (20b) (20a) 1 (24b) (2
 가 (24a) (24b)
 가 (26) (12) 1 (24b)
 2 (26a)

1

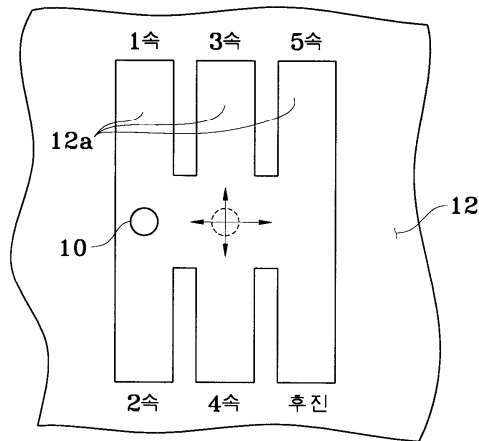

2

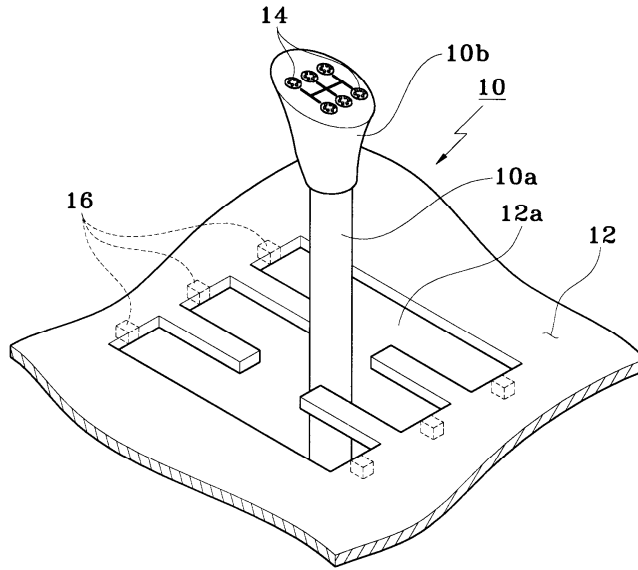

3

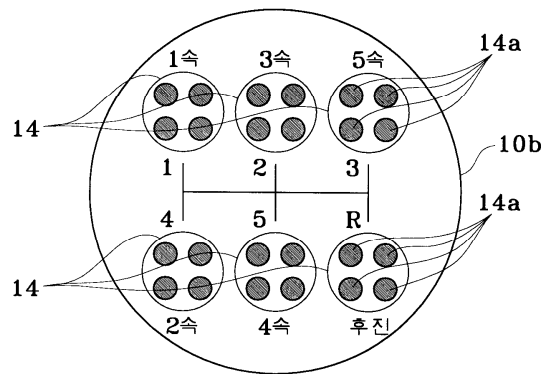

4

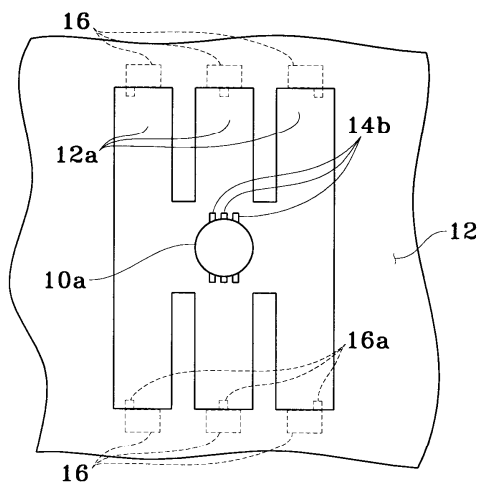

5

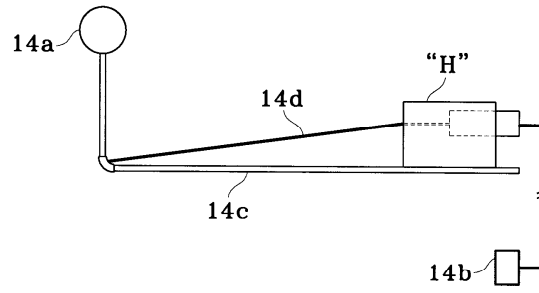

6

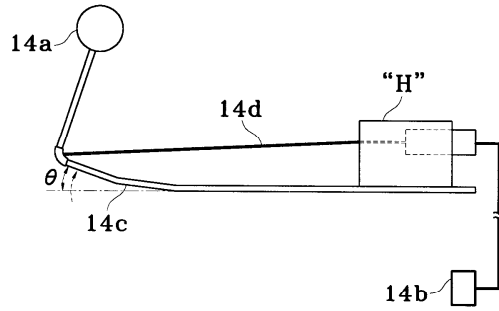

7

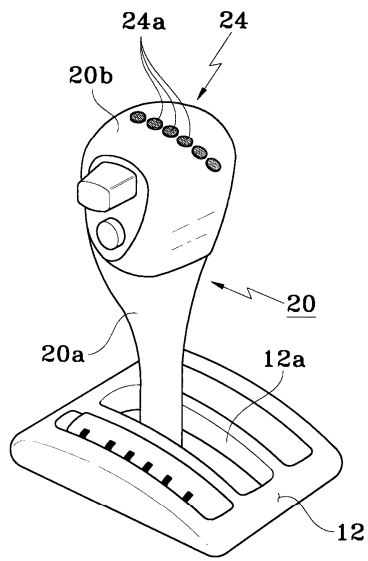

8

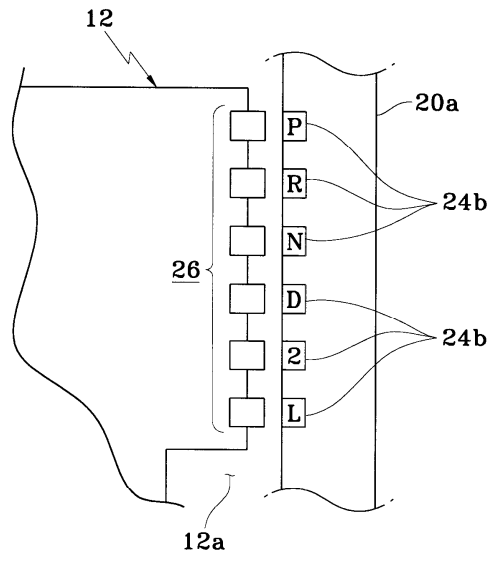

9

