

A. D. Shattuck.
Carding Engine.

N^o 15,784.

Patented Sep. 23, 1856

Fig. 2.

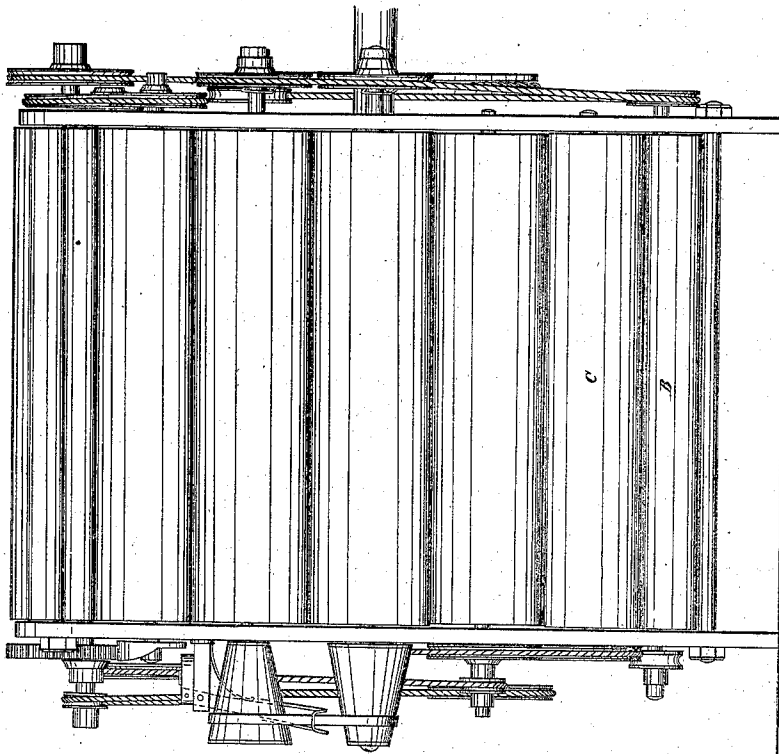
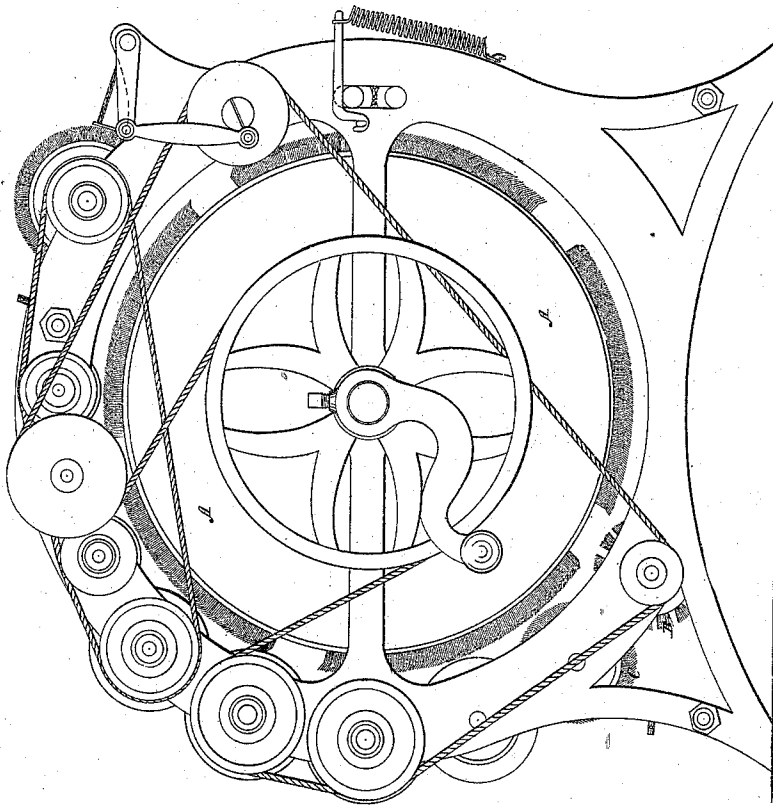

Fig. 1.



UNITED STATES PATENT OFFICE.

A. D. SHATTUCK, OF GRAFTON, MASSACHUSETTS.

IMPROVEMENT IN CARDING-ENGINES.

Specification forming part of Letters Patent No. 15,784, dated September 23, 1856.

To all whom it may concern:

Be it known that I, A. D. SHATTUCK, of Grafton, in the county of Worcester and State of Massachusetts, have invented a new and useful Improvement in Carding - Engines, of which the following is a full, clear, and exact description, reference being had to the annexed drawings, making part of this specification, in which—

Figure 1 is an end view; Fig. 2, a front view.

My invention has for its object to strip the main cylinder of the ordinary carding-engine continuously and constantly without the necessity of interrupting the operation of the card for the purpose and without producing the least break or unevenness of the lap; and my invention consists in the use of a stripper or clearer to the main cylinder, in connection with a doffer which is itself in turn stripped by the main cylinder, by which means the cotton is all taken off the latter and is immediately returned thereto, as will be hereinafter more fully explained.

In the said drawings the parts indicated in red, having no immediate reference to the

subject of my present invention, will require no further description.

A is the main cylinder; B, a brush-clothed cylinder running faster than the main cylinder, which it strips and cleans.

C is a doffer which receives the cotton from the stripper and is stripped by the main cylinder, which latter revolves eight times as fast as the doffer. The cotton is thus all taken off the main cylinder and is immediately returned thereto, the operation being continuous, and neither requiring the card to be stopped nor causing any break or interruption in the lap.

What I claim as my invention, and desire to secure by Letters Patent, is—

The stripper B, in combination with the doffer C and with the main cylinder of a carding-engine, operating in the manner substantially as herein set forth.

A. D. SHATTUCK.

Witnesses:

J. H. SMITH,
EDWD. N. FOOTE.