



- (51) International Patent Classification:
F16B 7/06 (2006.01) F16B 39/28 (2006.01)
F16G 11/12 (2006.01)
- (21) International Application Number: PCT/FI2016/050548
- (22) International Filing Date: 4 August 2016 (04.08.2016)
- (25) Filing Language: Finnish
- (26) Publication Language: English
- (30) Priority Data: 20155650 11 September 2015 (11.09.2015) FI
- (71) Applicant: MACGREGOR FINLAND OY [FI/FI]; Hal-
limestarinkatu 6, FI-20780 Kaarina (FI).
- (72) Inventor: ÖSTBERG, Juhana; Itäinen Rantakatu 60a C
54, FI-20810 Turku (FI).
- (74) Agent: HEINÄNEN OY; Äyritie 8 D, FI-01510 Vantaa
(FI).
- (81) Designated States (unless otherwise indicated, for every
kind of national protection available): AE, AG, AL, AM,
AO, AT, AU, AZ, BA, BB, BG, BH, BN, BR, BW, BY,
BZ, CA, CH, CL, CN, CO, CR, CU, CZ, DE, DK, DM,
DO, DZ, EC, EE, EG, ES, FI, GB, GD, GE, GH, GM, GT,
HN, HR, HU, ID, IL, IN, IR, IS, JP, KE, KG, KN, KP, KR,
KZ, LA, LC, LK, LR, LS, LU, LY, MA, MD, ME, MG,
MK, MN, MW, MX, MY, MZ, NA, NG, NI, NO, NZ, OM,

[Continued on next page]

(54) Title: MECHANISM FOR LOCKING A TURNBUCKLE

(57) Abstract: Mechanism for locking a turnbuckle, which turnbuckle comprises a screw rod (1) provided with a thread, and a frame part (2) that is provided with a corresponding thread and is rotatable in relation to the screw rod, which frame part has vertical bars (3, 4), and on the top end of which screw rod (1) a retainer (8) is installed. The invention is implemented in such a way that installed on at least one vertical bar (3, 4) is a locking means (10) that slides in the direction of the vertical bar, and that in its locking position collides with the retainer (8) on the screw rod (1) and prevents movement of the frame part (2) around the screw rod (1).

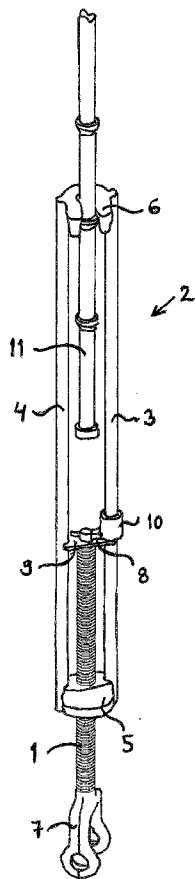

Fig. 1



WO 2017/042426 A1

PA, PE, PG, PH, PL, PT, QA, RO, RS, RU, RW, SA, SC, SD, SE, SG, SK, SL, SM, ST, SV, SY, TH, TJ, TM, TN, TR, TT, TZ, UA, UG, US, UZ, VC, VN, ZA, ZM, ZW.

SI, SK, SM, TR), OAPI (BF, BJ, CF, CG, CI, CM, GA, GN, GQ, GW, KM, ML, MR, NE, SN, TD, TG).

(84) Designated States (*unless otherwise indicated, for every kind of regional protection available*): ARIPO (BW, GH, GM, KE, LR, LS, MW, MZ, NA, RW, SD, SL, ST, SZ, TZ, UG, ZM, ZW), Eurasian (AM, AZ, BY, KG, KZ, RU, TJ, TM), European (AL, AT, BE, BG, CH, CY, CZ, DE, DK, EE, ES, FI, FR, GB, GR, HR, HU, IE, IS, IT, LT, LU, LV, MC, MK, MT, NL, NO, PL, PT, RO, RS, SE,

Declarations under Rule 4.17:

— *as to applicant's entitlement to apply for and be granted a patent (Rule 4.17(ii))*

Published:

— *with international search report (Art. 21(3))*

MECHANISM FOR LOCKING A TURNBUCKLE

The object of this invention is a mechanism for locking a
5 turnbuckle, which turnbuckle comprises a screw rod provided with
a thread, and a frame part that is provided with a corresponding
thread and is rotatable in relation to the screw rod, which frame
part has vertical bars, and on the top end of which screw rod a
retainer is installed.

10

The invention thus relates to a mechanism with which it is
endeavored to prevent unintended loosening, e.g. caused by
vibration of the ship's hull, of a turnbuckle being used for
tightening a lashing rod. Lashing rods are used more particularly
15 on cargo ships for securing containers to a lashing bridge or to the
ship's hull.

A turnbuckle is composed of a screw rod and a frame part, which
are connected to each other by means of a thread. The lashing rod
20 is tightened or loosened by means of the turnbuckle by rotating the
frame part in relation to the screw rod. One problem is that e.g.
the vibration of the ship unintentionally tries to loosen a
turnbuckle. Various locking mechanisms have been developed for
preventing this.

25

One such solution is presented in Finnish patent 122999, wherein
rotational movement is prevented by means of toothed pieces and
a pretensioning means.

30 Publication EP 1805077 B1 presents a turnbuckle, in which the
frame part is rotated in relation to the screw rod, between which
frame part and screw rod is installed a coupling part, which by
snap action enables rotational movement between the parts at
least in the tightening direction and resists movement in the
35 opposite direction.

Additionally, publication EP 2444692 B1 presents a locking mechanism that is known in the art.

The structures in these solutions that are known in the art are
5 complex and they have many moving parts, in which case manufacturing costs are also high. During use the operation of springs and other small parts can be disturbed by detritus or corrosion.

10 The aim of the current invention is to achieve a new type of mechanism for locking a turnbuckle, which mechanism is not conjoined with the problems occurring in known solutions. The mechanism according to the invention is characterized in that installed on at least one vertical bar is a locking means that slides
15 in the direction of the vertical bar and that in its locking position collides with the retainer on the screw rod and prevents movement of the frame part around the screw rod.

One preferred embodiment of the mechanism according to the
20 invention is characterized in that the locking means is shaped and dimensioned in such a way that it is possible for the bottom end of a lashing bar connected to the turnbuckle to extend in its extreme position up to the top end of the screw rod without the locking means preventing this, regardless of the attitude and height
25 position of the locking means.

Another preferred embodiment of the mechanism according to the invention is characterized in that the locking means is situated on the side of the center line of the turnbuckle in such a way that no
30 point of the locking means is situated on the imaginary extension of the screw rod as viewed in the upward direction of the screw rod.

Yet another preferred embodiment of the mechanism according to
35 the invention is characterized in that the locking means is a cylindrical sleeve installed on a vertical bar and sliding in the direction of the vertical bar.

One advantage of the invention that can be mentioned is that the locking function is automatic, i.e. the locking means drops into the lower position (locking position) by the effect of gravity. Thus the structure of the mechanism according to the invention is inexpensive and operationally reliable. In addition, the small outer dimensions and the location of the lock sleeve enable a larger range of length adjustment or a shorter structure for the turnbuckle itself.

10

In the following, the invention will be described in more detail by the aid of some preferred embodiments with reference to the attached drawings, wherein

15

Fig. 1 presents a turnbuckle according to the invention.

Fig. 2 presents a detail of a turnbuckle according to the invention when the locking means has been raised.

20

Fig. 3 presents a detail of a turnbuckle according to the invention when the locking means is in the locking position.

25

Fig. 4 presents another embodiment of the locking means.

Fig. 5 presents a third embodiment of the locking means.

30

Fig. 6 presents the mechanism according to the invention in a position in which the bottom end of the lashing bar is as close as possible to the top end of the screw rod.

35

Fig. 1 thus presents a turnbuckle according to the invention, the main components of which are a screw rod 1 and a frame part 2.

The frame part is composed of two vertical bars 3 and 4, a flange 5 and a slot part 6. A hole is made in the flange 5 of the frame part 2, which hole has an internal thread that matches the external thread of the screw rod. The flange 5 functions as a counterpart of the screw rod, enabling adjustment of the length of the turnbuckle by rotating the frame part 2 in relation to the screw rod 1. The slot part 6 at the top end of the frame part 2 enables connection of a lashing bar 11 to the turnbuckle. The screw rod 1 in turn has a fixed jaw 7, from which the screw rod 1 is fixed to its base, such as to a lashing bridge or to the hull of the ship.

A retainer is installed on the top end of the screw rod 1, which retainer is in this case a transverse retainer pin 8. The top end of the screw rod is also supported with a separate support plate 9 on the vertical rods 3 and 4 of the frame part 2. The screw rod is able to rotate freely in relation to the support plate 9 because there is a hole with clearance in the support plate. The support plate 9 is, in turn, able to slide in relation to the vertical bars 3 and 4 in their longitudinal direction.

A locking means is installed on the second vertical bar 3, which locking means is in this case a sleeve 10, which is able to slide freely in the direction of the vertical bar 3. When it is desired to adjust the length of the turnbuckle, i.e. to tighten or loosen the turnbuckle, the sleeve 10 is raised (Fig. 2), i.e. out of the locking position, and the frame part 2 is rotated around the screw rod 1. The vertical bars 3 and 4 thus fit to rotate around the retainer pin 8. After adjustment of the length, the sleeve is allowed to drop under the effect of gravity into its lower position, i.e. into the locking position (Fig. 3). When the tightened turnbuckle endeavors to loosen, e.g. due to the vibration of the ship, the sleeve 10 on the bottom end of the vertical bar 3 collides with and stops on the retainer pin 8 on the screw rod 1. In this case the frame part 2 is not therefore able to rotate around the screw rod 1 and the turnbuckle will not lose its set tightness.

Figs. 4 and 5 present two different embodiments, in which the locking mechanism is implemented with one larger component 10', 10'', which slides guided by the vertical bars 3 and 4 and in the direction of them, and which in its lower position prevents loosening of the turnbuckle. In Figs. 4 and 5 the component 10', 10'' is presented in its raised position, in which therefore rotation of the frame part 2 in relation to the screw rod 1 is possible.

Fig. 6 presents the mechanism according to the invention in a position in which the bottom end of a lashing bar 11 is close to the top end of the screw rod 1. This is achieved by shaping and dimensioning the locking means 10 to enable this extreme position. The locking means is thus situated on the side of the center line of the turnbuckle in such a way that no point of the locking means is situated on the imaginary extension of the screw rod 1 as viewed in the upward direction of the screw rod. The same is, of course, possible also in the embodiments presented by Figs. 4 and 5.

It is obvious to the person skilled in the art that the invention is not limited to the embodiments presented above, but that it can be varied within the scope of the claims presented below. The locking mechanism according to the invention can also be implemented with two or more separate sleeves 10, in which case there is one or more sleeves 10 on one or on both of the vertical rods 3 and 4. In this description the retainer is a retainer pin 8, but it can be some other kind of part suited to the same purpose or a shape, such as a cavity or groove, that functions in the manner of a retainer and is made directly in the end of the screw rod 1. For example, the diameter of the sleeve can be larger to the extent the sleeve extends directly into a cavity in the top end of the screw rod.

The characteristic features possibly presented in the description in conjunction with other characteristic features can also, if necessary, be used separately to each other.

CLAIMS

- 5 1. Mechanism for locking a turnbuckle, which turnbuckle comprises a screw rod (1) provided with a thread and a frame part (2) that is provided with a corresponding thread and is rotatable in relation to the screw rod, which frame part has vertical bars (3, 4), and on the top end of which screw rod (1) a retainer (8) is installed, 10 **characterized** in that installed on at least one vertical bar (3, 4) is a locking means (10, 10', 10'') that slides in the direction of the vertical bar, and that in its locking position collides with the retainer (8) on the screw rod (1) and prevents movement of the frame part (2) 15 around the screw rod (1).
- 20 2. Mechanism according to claim 1, **characterized** in that the locking means (10, 10', 10'') is shaped and dimensioned in such a way that it is possible for the bottom end of a lashing bar (11) connected to the turnbuckle to extend in its extreme position up to the top end of the screw rod (1) without the locking means preventing this, regardless of the attitude and height position of the locking means. 25
- 30 3. Mechanism according to claim 1 or 2, **characterized** in that the locking means (10, 10', 10'') is situated on the side of the center line of the turnbuckle in such a way that no point of the locking means is situated on the imaginary extension of the screw rod (1) as viewed in the upward direction of the screw rod.
- 35 4. Mechanism according to any of claims 1-3, **characterized** in that the locking means is a cylindrical sleeve (10) installed on a vertical bar and sliding in the direction of the vertical bar.

5. Mechanism according to any of claims 1-4, **characterized** in that there are two units of locking means (10), one installed on each vertical bar.
- 5 6. Mechanism according to any of claims 1-4, **characterized** in that there are a number of locking means (10), installed on one or on both of the vertical bars (3, 4).
- 10 7. Mechanism according to any of claims 1-3, **characterized** in that the locking means (10', 10'') is an integral component that is supported on both vertical bars and that slides in the direction of the vertical bars (3, 4).

1/3

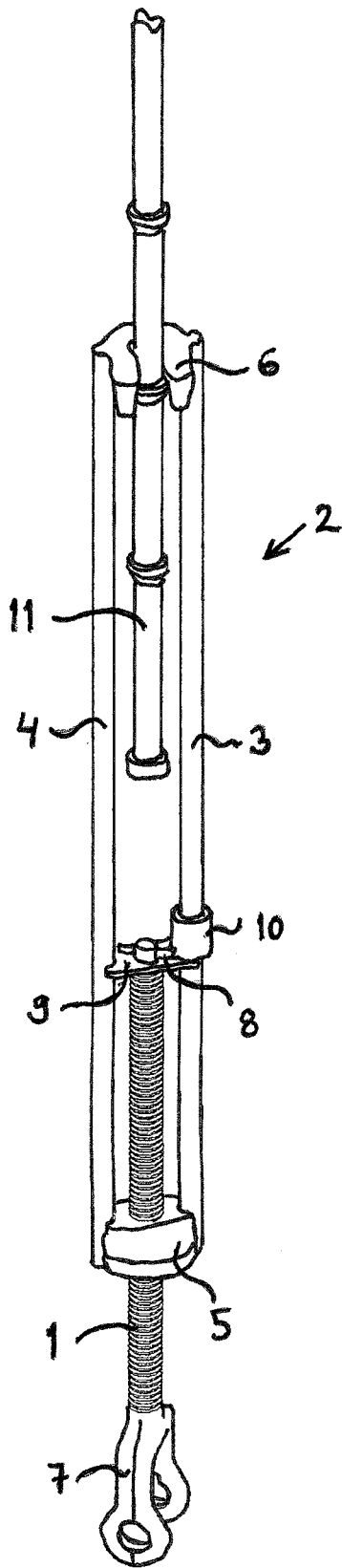

Fig. 1

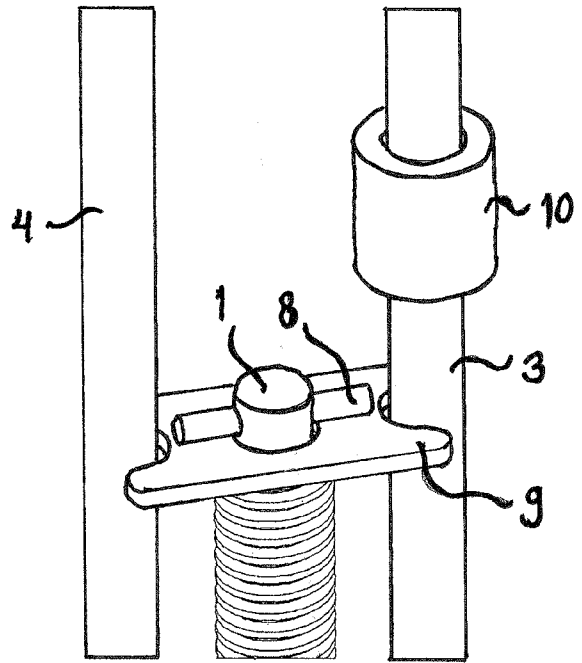

Fig. 2

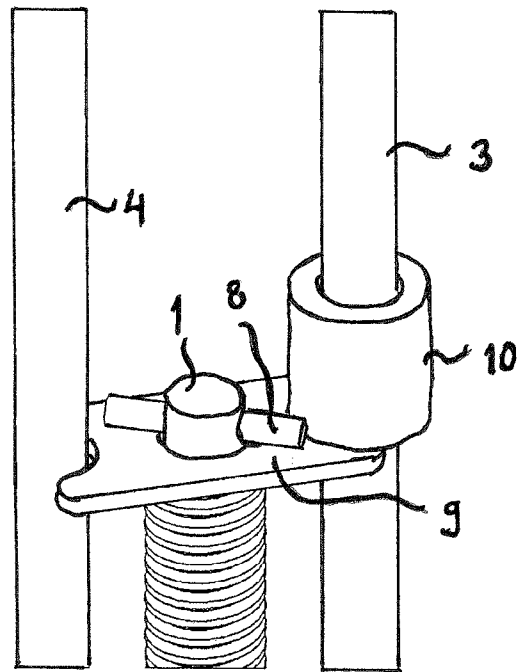

Fig. 3

2/3

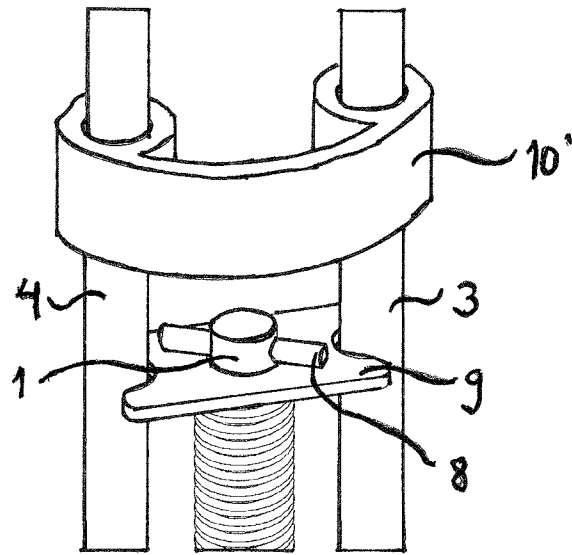

Fig. 4

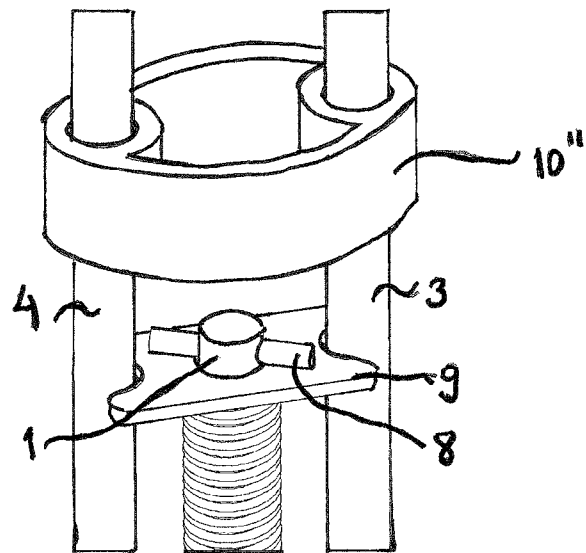

Fig. 5

3/3

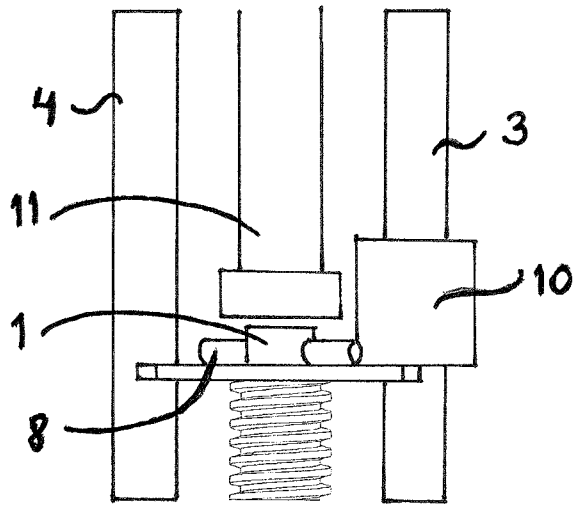

Fig.6

INTERNATIONAL SEARCH REPORT

International application No.

PCT/FI2016/050548

A. CLASSIFICATION OF SUBJECT MATTER

See extra sheet

According to International Patent Classification (IPC) or to both national classification and IPC

B. FIELDS SEARCHED

Minimum documentation searched (classification system followed by classification symbols)

IPC: F16B, B63B

Documentation searched other than minimum documentation to the extent that such documents are included in the fields searched

FI, SE, NO, DK

Electronic data base consulted during the international search (name of data base, and, where practicable, search terms used)

EPODOC, WPIAP

C. DOCUMENTS CONSIDERED TO BE RELEVANT

Category*	Citation of document, with indication, where appropriate, of the relevant passages	Relevant to claim No.
X	KR 20130085770 A (SAMSUNG HEAVY IND [KR]) 30 July 2013 (30.07.2013) Figures 1-3 & machine translation into English by the KIPO [online] [retrieved 23.11.2016] the whole document	1, 7
X	DE 20203067 U1 (MACGREGOR CONVER GMBH [DE]) 08 August 2002 (08.08.2002) page 12, line 28 – page 14, line 9 ; figures. 3, 14-17	1, 4
X	US 6908268 B1 (HSIEH DAVID [TW]) 21 June 2005 (21.06.2005) column 2, line 23 – column 4, line 29 ; figure 3	1, 7
A	DE 10108519 A1 (WADER WILLI GMBH [DE]) 05 September 2002 (05.09.2002) Figure 1	1-7

 Further documents are listed in the continuation of Box C.
 See patent family annex.

* Special categories of cited documents:	"T" later document published after the international filing date or priority date and not in conflict with the application but cited to understand the principle or theory underlying the invention
"A" document defining the general state of the art which is not considered to be of particular relevance	"X" document of particular relevance; the claimed invention cannot be considered novel or cannot be considered to involve an inventive step when the document is taken alone
"E" earlier application or patent but published on or after the international filing date	"Y" document of particular relevance; the claimed invention cannot be considered to involve an inventive step when the document is combined with one or more other such documents, such combination being obvious to a person skilled in the art
"L" document which may throw doubts on priority claim(s) or which is cited to establish the publication date of another citation or other special reason (as specified)	"&" document member of the same patent family
"O" document referring to an oral disclosure, use, exhibition or other means	
"P" document published prior to the international filing date but later than the priority date claimed	

Date of the actual completion of the international search

25 November 2016 (25.11.2016)

Date of mailing of the international search report

29 November 2016 (29.11.2016)

Name and mailing address of the ISA/FI
Finnish Patent and Registration Office
P.O. Box 1160, FI-00101 HELSINKI, Finland
Facsimile No. +358 9 6939 5328

Authorized officer
Pekka Ruha
Telephone No. +358 9 6939 500

CLASSIFICATION OF SUBJECT MATTER

IPC
F16B 7/06 (2006.01)
F16G 11/12 (2006.01)
F16B 39/28 (2006.01)

INTERNATIONAL SEARCH REPORT
Information on Patent Family Members

International application No.
PCT/FI2016/050548

Patent document cited in search report	Publication date	Patent family members(s)	Publication date
KR 20130085770 A	30/07/2013	KR 101334355 B1	29/11/2013
.....			
DE 20203067 U1	08/08/2002	AT 330841 T	15/07/2006
		AU 2003210371 A1	09/09/2003
		CN 1688477 A	26/10/2005
		CN 100556753 C	04/11/2009
		DE 50303982 D1	03/08/2006
		DK 1534584 T3	30/10/2006
		EP 1534584 A2	01/06/2005
		EP 1534584 B1	21/06/2006
		ES 2268385 T3	16/03/2007
		WO 03072427 A2	04/09/2003
.....			
US 6908268 B1	21/06/2005	None	
.....			
DE 10108519 A1	05/09/2002	None	
.....			