

(19) World Intellectual Property
Organization
International Bureau



(43) International Publication Date
25 August 2005 (25.08.2005)

PCT

(10) International Publication Number
WO 2005/077259 A1

- (51) International Patent Classification⁷: A61B 3/113
- (21) International Application Number: PCT/US2005/003780
- (22) International Filing Date: 4 February 2005 (04.02.2005)
- (25) Filing Language: English
- (26) Publication Language: English
- (30) Priority Data: 60/541,590 4 February 2004 (04.02.2004) US
- (71) Applicant (for all designated States except US): THE JOHNS HOPKINS UNIVERSITY [US/US]; 34th & Charles Street, Baltimore, MD 21218 (US).
- (72) Inventors; and
- (75) Inventors/Applicants (for US only): MIGLIACCIO, Americo, A. [AU/US]; 21B Matinee Court, Owings Mills, MD 21117 (US). DELLA SANTINA, Charles [US/US]; 912 Fairway Drive, Towson, MD 21286 (US). MACDOUGALL, Hamish, G. [AU/AU]; 309/99 Dowling Street, Woolloomooloo, NSW 2011 (AU).
- (74) Agent: GUFFEY, Larry, J.; World Trade Center, Suite 1800, 401 East Pratt Street, Baltimore, MD 21202 (US).
- (81) Designated States (unless otherwise indicated, for every kind of national protection available): AE, AG, AL, AM, AT, AU, AZ, BA, BB, BG, BR, BW, BY, BZ, CA, CH, CN, CO, CR, CU, CZ, DE, DK, DM, DZ, EC, EE, EG, ES, FI, GB, GD, GE, GH, GM, HR, HU, ID, IL, IN, IS, JP, KE, KG, KP, KR, KZ, LC, LK, LR, LS, LT, LU, LV, MA, MD, MG, MK, MN, MW, MX, MZ, NA, NI, NO, NZ, OM, PG, PH, PL, PT, RO, RU, SC, SD, SE, SG, SK, SL, SY, TJ, TM, TN, TR, TT, TZ, UA, UG, US, UZ, VC, VN, YU, ZA, ZM, ZW.
- (84) Designated States (unless otherwise indicated, for every kind of regional protection available): ARIPO (BW, GH, GM, KE, LS, MW, MZ, NA, SD, SL, SZ, TZ, UG, ZM, ZW), Eurasian (AM, AZ, BY, KG, KZ, MD, RU, TJ, TM), European (AT, BE, BG, CH, CY, CZ, DE, DK, EE, ES, FI, FR, GB, GR, HU, IE, IS, IT, LT, LU, MC, NL, PL, PT, RO, SE, SI, SK, TR), OAPI (BF, BJ, CF, CG, CI, CM, GA, GN, GQ, GW, ML, MR, NE, SN, TD, TG).
- Published:
- with international search report
 - before the expiration of the time limit for amending the claims and to be republished in the event of receipt of amendments

[Continued on next page]

(54) Title: METHOD AND APPARATUS FOR THREE-DIMENSIONAL VIDEO-OCULOGRAPHY

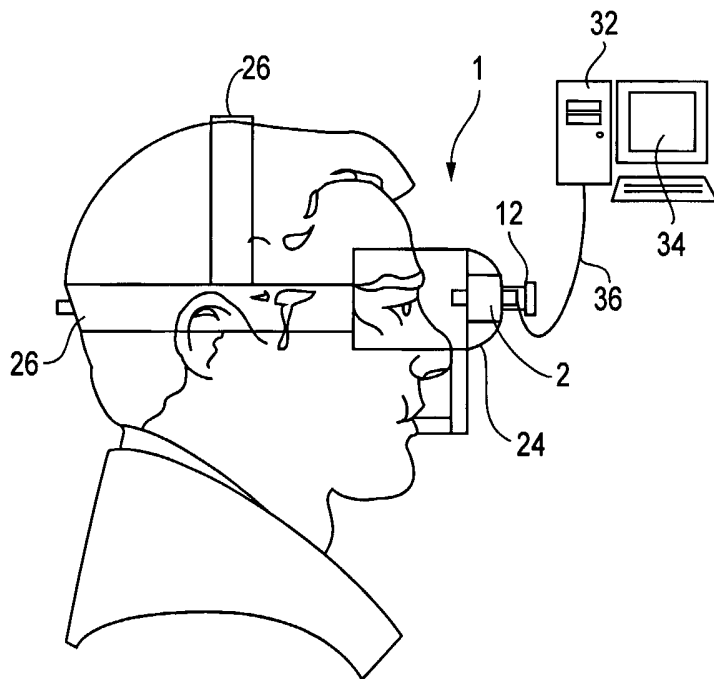

(57) Abstract: A device (1) for measuring the three-dimensional movements of an eye includes: (a) a marker array (6) that identifies prescribed positions on the eye whose movements are to be measured, (b) a digital camera (2) for capturing the two-dimensional images of this marker array (6) as the eye is moved, (c) a light source (12) that illuminates the marker array (6) with an output that is outside the spectral range of the camera (2), (d) light sources (20) that are used to align the camera's optical axis with the center of the eye, (e) an algorithm for computing the three-dimensional positions of the marker array (6) from the information contained in the captured digital images, and (f) a base (16) for fixing the position of the camera relative to the position of the eye, wherein the materials of the marker array (6) are chosen so that the array has the ability to, when illuminated as described above, give off energy that is in the spectral range of the device's camera (2).

WO 2005/077259 A1



For two-letter codes and other abbreviations, refer to the "Guidance Notes on Codes and Abbreviations" appearing at the beginning of each regular issue of the PCT Gazette.

1 METHOD AND APPARATUS FOR THREE-DIMENSIONAL VIDEO-
2 OCULOGRAPHY
3
4
5
6
7
8
9
10

11 CROSS-REFERENCE TO RELATED APPLICATION
12

13 This application claims the benefit of U.S. Provisional Patent Application No.
14 60/541,590, filed February 4, 2004, by the present inventors and assigned to The
15 Johns Hopkins University.
16
17
18

19 STATEMENT AS TO FEDERALLY SPONSORED RESEARCH
20

21 This invention was made with Government support under Grant No. K08-
22 DC006216 to Dr. Della Santina, which was awarded by the National Institute On
23 Deafness And Other Communication Disorders. The Government may have
24 certain rights in this invention.
25
26
27

BACKGROUND OF THE INVENTION

1
2
3
4
5
6
7
8
9
10
11
12
13
14
15
16
17
18
19
20
21
22
23
24
25
26
27
28
29
30
31
32
33
34

1. FIELD OF THE INVENTION

This invention relates to oculography (i.e., eye movement recordings) and methods and devices for making non-contact measurements of the rotations of essentially spherical bodies. More particularly, the present invention relates to inexpensive, real-time, three-dimensional, video-oculography that utilizes a specialized marker array which is placed on the eye.

2. DESCRIPTION OF PRIOR ART

Precise and accurate measurement of eye rotation is essential for the clinical evaluation and scientific study of vestibular (balance) and oculomotor (eye movement) disorders. Common types of such disorders often result in those afflicted reporting problems with dizziness.

The magnitude of such disorders can be noted by observing that over ninety million Americans suffer from dizziness; it is the ninth most common reason adults visit a primary care doctor. Thirty-four percent of Americans age 65-74 suffer from dizziness significant enough to limit their activities of daily life, making it the third most common medical complaint among this group; dizziness is the most common complaint in patients 75 years and older.

Eye rotation measurements are also important because they can be used in other applications, such as input to various computer systems for assorted purposes: data entry, command and control (e.g., navigation of computer-controlled equipment), communication, and the enhancement of virtual reality-based displays.

The "gold standard" method for measuring three-dimensional eye position is the scleral search coil technique. It involves search coils being either implanted on or affixed to the eye and their orientation identified by subjecting them to uniform, stable magnetic fields. However, even this method can suffer from a number of drawbacks that can affect measurement reliability (e.g., implantation of search coils can restrict or distort eye movements due to eye scarring and

1 inflammation or coil lead tension, the imposed magnetic field can be distorted by
2 metallic objects and by currents flowing in nearby equipment).

3 These drawbacks of the search coil technique have prompted efforts to
4 develop video-oculographic (VOG) systems for the measurement of three-
5 dimensional eye rotations. See FIG. 1 for a description of the coordinate system
6 and the terminology used herein to describe rotational eye movements.

7 These systems typically make two-dimensional (horizontal and vertical)
8 eye rotation determinations by tracking the pupil and/or a corneal reflection.

9 To determine eye rotations in a third dimension (torsional), most currently
10 available VOG systems either track two or more landmarks on the eye or measure
11 and track changes in iral contrast along a circular sampling path. In humans,
12 pronounced iral striations make iral contrast tracking practical, whereas, in
13 animals that do not have pronounced iral striations, it is more practical to track
14 attached landmarks.

15 However, there are problems with these methodologies and the
16 conventional VOG systems. For example, the quality of data using existing
17 methods is often compromised due to misalignment of the camera with the eye.
18 This misalignment can introduce errors $> 10\%$. Reflections of the light source on
19 the eye and/or shading of the landmarks/pupil can produce either loss of the
20 landmark or incorrect calculation of its centroid position. VOG techniques that
21 track the pupil are inherently problematic because the contrast between the iris
22 and pupil is not large. This non-exact demarcation zone makes it difficult to
23 precisely define the pupil region and calculate the pupil centroid position.

24 Additionally, current three-degree eye measurement VOG systems that
25 track landmarks on the eye employ complex and relatively inefficient algorithms.
26 Most require considerable post-hoc processing of the data collected to enable
27 computation of an eye's torsional movements. Meanwhile, those few systems that
28 provide real-time measurements of eye torsional motions are prohibitively
29 expensive for most clinical and diagnostic applications. Most of these commercial
30 systems are for human applications only i.e. they track the pupil and iral signature.
31 Given the same technological limitations pupil/iral tracking is significantly slower
32 than landmark tracking.

33 Current methods and devices for measuring three-dimensional eye
34 movements need to be improved by making them: (a) less expensive, (b) more
35 portable so that such measurements can be made other than in only clinical

1 laboratory settings, and (c) faster operating so to enable them to provide real-time
2 measurements which can be more timely correlated for diagnostic purposes with
3 the bodily motions which may be precipitating such eye movements.

4 The present inventors have been working in this technical field and
5 towards the development of such improved methods and devices for some time.
6 Much of their earlier research is applicable to the methodologies described herein
7 and has been documented in the scientific literature. See for example: Migliaccio,
8 MacDougall, Minor and Della Santina, "Inexpensive System for Real-Time 3-
9 Dimensional Video-Oculography Using a Fluorescent Marker Array," submitted
10 for publication to the Journal of Neuroscience Methods, February 2004, and
11 MacDougall, "The Human Eye-Movement Response To Maintained Surface
12 Galvanic Vestibular Stimulation," Ph.D. dissertation, University of Sydney, May
13 2003.

1
2
3
4
5
6
7
8
9
10
11
12
13
14
15
16
17
18
19
20
21
22
23
24
25

3. OBJECTS AND ADVANTAGES

There has been summarized above, rather broadly, the background that is related to the present invention in order that the context of the present invention may be better understood and appreciated. In this regard, it is instructive to also consider the objects and advantages of the present invention.

It is an object of the present invention to provide improved, lower cost methods and devices for making eye rotation measurements.

It is another object of the present invention to provide improved, more portable methods and devices for making eye rotation measurements.

It is yet another object of the present invention to provide improved, faster operating methods and devices for making eye rotation measurements.

It is a further object of the present invention to provide improved diagnostic methods and devices for assessing vestibular and oculomotor disorders.

It is also an object of the present invention to provide improved methods and devices for providing eye rotation measurement input to various computer systems for a wide assortment of applications (e.g., data entry, command and control, communication, and the enhancement of virtual reality-based displays).

These and other objects and advantages of the present invention will become readily apparent as the invention is better understood by reference to the accompanying summary, drawings and the detailed description that follows.

1
2
3
4
5
6
7
8
9
10
11
12
13
14
15
16
17
18
19
20
21
22
23
24
25
26
27
28
29
30
31
32
33
34
35

SUMMARY OF THE INVENTION

Recognizing the needs for the development of improved methods and apparatuses for making eye rotation measurements, the present invention is generally directed to satisfying the needs set forth above and overcoming the disadvantages identified with prior art devices and methods.

In a first preferred embodiment, such a method for measuring the three-dimensional movements of an eye includes the steps of: (a) marking an array of positions on the eye whose movements are to be measured, (b) illuminating this marker array with a light source whose output is in a prescribed first spectral range, (c) capturing along a prescribed optical axis the two-dimensional, digital images of this array of eye-marked positions as the eye is moved, wherein these images are captured in a second spectral range that does or does not overlap with the illumination's prescribed first spectral range, (c) wherein this prescribed optical axis having been aligned with the center of the eye, and (d) computing the three-dimensional positions of the array of eye-marked positions from the information contained in the captured digital images.

In a still further preferred embodiment, the present invention takes the form of a device for measuring the three-dimensional movements of an eye. This device includes: (a) a marker array that identifies prescribed positions on the eye whose movements are to be measured, (b) a digital video camera for capturing the two-dimensional, digital images of this marker array as the eye is moved, (c) a light source that illuminates the marker array with an output that is outside the spectral range of the camera, (d) light sources that are used to align the camera's optical axis with the center of the eye, (e) an algorithm for computing the three-dimensional positions of the marker array from the information contained in the captured digital images, and (f) a base for fixing the position of the camera relative to the position of the eye, wherein the materials of the marker array are chosen so that the array has the ability to, when illuminated as described above, give off energy that is in the spectral range of the device's camera.

Thus, there has been summarized above, rather broadly, the present invention in order that the detailed description that follows may be better understood and appreciated. There are, of course, additional features of the

1 invention that will be described hereinafter and which will form the subject matter
2 of any eventual claims to this invention.

3

4

5

6

7

8

9

10

11

12

13

14

15

16

BRIEF DESCRIPTION OF THE DRAWINGS

1
2
3
4
5
6
7
8
9
10
11
12
13
14
15
16
17
18
19
20
21
22

FIG. 1 displays the coordinate system and illustrates the terminology used herein to describe rotational eye movements.

FIGS. 2a and 2b are schematic top and front views of an experimental set-up of a preferred embodiment of the present invention that has been configured to allow for the eye rotation measurements of a laboratory animal.

FIGS. 3a and 3b are schematic side and top views of an experimental set-up of the present invention that has been configured to allow for eye position measurements in humans.

FIG. 4 is a schematic of another embodiment of the present invention that is suitable for measuring human eye movements in those instances in which it is desired to not obstruct the patient's view.

FIG. 5 illustrates a marker array of the present invention in which the array is placed on an annular contact lens which is to be worn by the patient whose eye movements are to be measured.

FIGS. 6a-6b illustrate the eye rotational position calculation aspects of the present invention.

1 DETAILED DESCRIPTION OF THE PREFERRED EMBODIMENT

2

3 Before explaining at least one embodiment of the present invention in
4 detail, it is to be understood that the invention is not limited in its application to
5 the details of construction and to the arrangements of the components set forth in
6 the following description or illustrated in the drawings. The invention is capable
7 of other embodiments and of being practiced and carried out in various ways.
8 Also, it is to be understood that the phraseology and terminology employed herein
9 are for the purpose of description and should not be regarded as limiting.

10 Although the foregoing disclosure relates to preferred embodiments of the
11 invention, it is understood that these details have been given for the purposes of
12 clarification only. Various changes and modifications of the invention will be
13 apparent, to one having ordinary skill in the art, without departing from the spirit
14 and scope of the invention.

15 Described herein is an inexpensive technique and device **1** for the real-
16 time measurement of three-dimensional eye position. In a preferred embodiment,
17 it uses a digital video camera **2** with a modified lens **4** to track an array of three
18 1mm x 1 mm markers **6** on a piece of plastic film **8** that is affixed to the cornea or
19 sclera of the eye. Depending on the spectral sensitivity of the specific camera **2**
20 used, an optical filter or filtering mirror **10** can be used to improve the contrast
21 observed by the camera.

22 To increase contrast between the markers **6** and unwanted corneal
23 reflections, the markers **6**, in a first preferred embodiment, can be fabricated from
24 materials that give them a fluorescent property. The markers are illuminated with
25 an ultra-violet light source **12** whose output is outside the camera's range of
26 spectral sensitivity.

27 The experimental arrangement and alignment of the camera with respect to
28 the eye whose motions are to be measured is critical to achieving accurate
29 measurements.

30 In a preferred embodiment of the present invention that is suitable for use
31 in animal experiments, this desired alignment is achieved by using a suitable head
32 mounting apparatus **14**. Connected to this apparatus **14** is a base **16** which
33 provides the means on which to mount the camera so that it is pointing through the
34 center of the eye.

1 See FIGS. 2a and 2b for schematics of the experimental set-up of the
2 present invention when the head mounting apparatus and base are configured to
3 accommodate a laboratory animal whose eye rotations are to be measured in
4 response to various applied stimuli. In this situation a gimbal device **18** is used to
5 hold the animal.

6 In this experimental setup, care must be taken to minimize possible
7 translational and angular alignment errors between the camera **2** and the targeted
8 eye. Translational misalignment occurs when the camera **2** is not pointing
9 through the center of the eye. To achieve the necessary translational alignment,
10 four alignment light sources **20** (e.g., 3 mm diameter white LEDs, NSPW300BS,
11 Nichia Tokushima, Japan) are positioned around the camera **2** in the form of a
12 right-angle cross, with the light sources **20** facing the eye and equidistant from the
13 center of the lens. It should be noted that these alignment light sources could also
14 be placed at differing prescribed distances from the optical axis and they could
15 still be used to assist in providing translational alignment, but with a slightly more
16 complex alignment procedure. Also, it is not absolutely necessary to use four
17 light sources, as two symmetrically placed light sources or a single light source,
18 with its image centered on the camera lens by using a partial mirror, could also be
19 used.

20 Translational alignment can be achieved by noting that when the camera's
21 optical axis is perfectly orthogonal to a targeted spherical, symmetric, convex
22 reflective surfaces (such as an eye), the four LED reflections seen in the video
23 image are centered on and equidistant from the center pixel of the image. If the
24 camera **2** is tilted with respect to the imaged surface, the LED reflections are no
25 longer equidistant from each other, and the center of the cross they define is no
26 longer aligned with the center pixel of the image. The mounting of the camera to
27 the base is such as to provide the necessary flexibility in its orientation so as to
28 ensure in a pre-test calibration that the reflections seen in the video image are
29 centered on and equidistant from the center of the image. Alternatively, as in the
30 animal experiments, the device holding the animal may provide the means for
31 achieving this desired alignment.

32 Pure angular misalignment occurs when the camera **2** is pointing through
33 the center of the eye, but the camera coordinate system is not rotationally aligned
34 with the reference coordinate system. In the animal experiments conducted in
35 support of this development effort, the reference coordinate system aligns with the

1 animal's head (specifically, with the plane through the animal's horizontal
2 semicircular canals, the midsagittal plane, and the coronal plane orthogonal to
3 these), which in turn is aligned with the head mount apparatus 14. To ensure
4 correct angular orientation of the cameras with respect to the base (and thus to the
5 animal's head), each camera 2 is mounted on a rotating turret 22 that is adjustable
6 in azimuth and elevation.

7 Each turret 22 maintains the torsional position of the camera 2 at zero
8 degrees with respect to the head coordinate system. The azimuth and elevation of
9 the camera 2 with respect to this system can be measured with a protractor to an
10 accuracy of 0.25°. These angles are used to convert measured eye rotations into
11 the head coordinate frame of reference.

12 It can be noted that such angular misalignment errors can be corrected by
13 multiplying each rotation matrix representing instantaneous eye position by the
14 matrix describing rotation from the incorrect frame of reference to the correct
15 frame of reference.

16 Mixed angular plus translational misalignment occurs when the camera 2
17 is first brought into perfect alignment and then is rotated so that the camera's optic
18 axis changes direction and no longer points through the center of rotation of the
19 eye. The error due to this combined misalignment can be corrected post-hoc if the
20 translational and angular deviation from the ideal camera position are known.

21 FIGS. 3a and 3b present schematic side and top views of an experimental
22 set-up of the present invention that has been configured to allow for eye position
23 measurements in humans. Again, the basic parts of the present invention are seen
24 to be a digital video camera 2 with a modified lens 4 and optical filter 10 that are
25 used to track an array of three 1 mm x 1 mm markers 6 positioned on the cornea
26 of the patient's eye and illuminated with a suitable light source 12.

27 In this embodiment, a suitable eye-mask type configuration 24, with its
28 head mounting straps 26, is used to mount and orient the camera 2 and light source
29 12 in front of the eye whose motions are to be measured. Alignment lights 20
30 (e.g., LEDs which may be visible, infrared or ultraviolet light) are symmetrically
31 positioned about the camera optical axis and are here shown to be mounted on the
32 camera's housing, but may also be mounted in other positions sufficient to
33 illuminate the eye (e.g., on an inner surface of the mask or external to the mask).

34 Shown in FIG. 4 is another embodiment suitable for measuring human eye
35 movements in those instances in which it is desired to not obstruct the patient's

1 view. In this embodiment, a mirror 28 which is partially transparent is mounted
2 and aligned in front of the patient's eyes in such a manner that it allows the
3 camera to be mounted to the side of the patient's eyes.

4 It should be recognized that there exist many alternative ways to mount a
5 camera attached to a suitable head device or mask so that eye movements can be
6 tracked and recorded. For example, a camera could be mounted down nearer a
7 patient's cheeks so that the camera looks up into the eyes and doesn't obstruct
8 one's straight ahead vision. All such camera orientations and consequent
9 modifications of the mask or head device are considered to come within the realm
10 of the current invention.

11 It can be noted that the development of a high frame rate version of the
12 present invention has been facilitated by recent advances in complementary metal
13 oxide semiconductor (CMOS) imaging technology, digital video cameras and
14 computer interfaces.

15 CMOS imaging technology has, for many years, been considered to be
16 inferior to charge-coupled devices (CCD). However, CMOS technology does
17 have one major advantage over CCDs in that it can be manufactured using the
18 same methods and equipment used for normal silicon chip production. For this
19 reason CMOS technology is cheaper and evolves at a much faster rate than CCD
20 sensors, which can only be made by a small number of large manufacturers. The
21 quality of video images produced by CMOS sensors is now as good as, or in some
22 cases better than, those from CCDs.

23 CMOS technology also allows for the integration of video processing on
24 or near the sensor itself. This processing provides the opportunity to simplify the
25 eye movement analysis task by shifting some of the processing burden on to the
26 camera hardware and off the computer CPU. Tasks such as the automatic
27 adjustment of brightness and contrast, the dynamic modification of look-up tables,
28 conversion to bitmap, and variable region of interest can all be done in the camera.

29 Another important development in camera technology is the increasing use
30 of digital imaging systems. Digital video cameras digitize on or close to CMOS
31 or CCD and avoid the problems of noise and interference inherent to systems that
32 pass analogue video signals down long leads. Digital video cameras are proving
33 to be smaller, lighter and cheaper, and have lower power consumption than an
34 equivalent combination of analogue camera and acquisition card for digital-to-
35 analogue conversion.

1 Digital cameras can interface directly with a number of high-speed bus
2 types, including Firewire (IEEE1394) and USB 2.0 that are standard, built-in
3 features of recent PC and Macintosh computers. Because laptop computers also
4 incorporate these high-speed bus technologies, eye movement recording systems
5 can now become truly mobile.

6 A laptop, notebook or sub-notebook computer can analyze or store video
7 data from a camera without any external source of power. This means that video
8 eye movement analysis systems can now be used at a patient's bedside in the
9 clinic or carried by a freely moving subject untethered to an experimental
10 apparatus.

11 The biggest advantage of digital camera systems for eye movement
12 analysis may be that they avoid the limits imposed by analogue video standards.
13 It is possible to exceed the 25-30 Hz frame rates of domestic video equipment by:
14 (a) de-interlacing frames into two fields, (b) using special double-speed cameras
15 with more than one analogue video output, (c) using multiple digital to analogue
16 converters, and (d) modifying camera electronics. These methods are
17 complicated, processor intensive, and often very expensive because there is a
18 small market for this esoteric equipment. Digital cameras can be programmed to
19 transfer images of arbitrary size, adjustable pixel depth, variable region of interest,
20 and have frame rates limited only by the bandwidth of their digital hardware.
21 Since the Firewire bus permits a throughput of 400 Mbps and a UBS 2 a
22 throughput of 480 Mbps, a high fame rate is possible, especially by transferring to
23 the computer only the region of the image that is useful for eye movement
24 analysis.

25 These advancements have been especially important in the development of
26 portable eye movement measurement systems suitable for use with humans. This
27 portability has been made possible by the development of the above described,
28 new digital (IEEE 1394, "Firewire" or USB 2.0) camera technology. These
29 cameras can be directly connected to signal and power via the Firewire port on
30 laptop computers so as to yield a stand-alone, wireless and battery-powered eye
31 movement analysis system that is capable of processing eye movements at 30 Hz
32 online and in real time. The use of notebook computers and even the new sub-
33 miniature notebook computers (e.g., Sony PictureBook which weights less than 1
34 kg) hold the promise of adding even more portability to such systems.

1 A camera 2 suitable for use in the system of the present invention was
2 found to be an IEEE 1394 Firewire webcam (PYRO1394 WebCam, ADS
3 Technologies, USA) retrofitted with ¼" format 16.0 mm focal length, f/2.0 C-
4 mount board lens (BL160, Allthings Inc., Australia). This camera was used to
5 acquire 640 x 480 pixel B&W (8-bit) images at 30 Hz.

6 For use with such a camera and a 16 mm lens 4, a 5 mm plastic spacer is
7 placed between the lens housing and the printed circuit board of the webcam so as
8 to allow the camera to be focused on a point 50 mm away.

9 National Instruments LabVIEW 7.0, NI-IMAQ Vision 7.0.1 and NI-IMAQ
10 for IEEE 1394 Cameras 1.5 standard modules were used to control camera
11 settings such as contrast and brightness and to correct for lens distortion and
12 perspective.

13 Standard NI-IMAQ modules were used to change the image threshold so
14 that only the markers 6 were visible on a black background and to determine the
15 center of each marker using a center of mass algorithm.

16 Camera magnification is set so that the medial and lateral canthi are at the
17 edges of the video image. Pixel size was calibrated using a known distance
18 between markers 6 and verified by using a micrometer.

19 Appropriate light sources 12 for this system include a diffuse ultraviolet
20 (UV-A) light source (360 nm peak, 9 Watt, FPX7BLB, Ushio Inc., Japan) or 80
21 nm UV-A light-emitting diodes (LEDs) (SSL-LX5093SUVC, Lumex Inc.).

22 Depending on the spectral sensitivity of the specific camera used, a UV cut
23 filter 10 (SKYLIGHT 1B Hoya, Japan) or a yellow pass filter (K2 yellow filter
24 Hoya, Japan) can be used to improve contrast. No filter was necessary when the
25 webcams described above were used because their color CCD is already less
26 sensitive to UV than most monochrome image sensors.

27 The maximum allowable exposure of UV-A (320-400 nm) that will not
28 harm the eye (cornea and lens) for human use is 1 J/cm². The "black light" or
29 UV-A lamp (sometimes called a "Wood's Lamp") that was used in this invention's
30 development work is not considered hazardous because the UV-A radiance at the
31 lamp surface is only about 3 mW/cm². At 30 cm distance the UV-A radiance at
32 the eye surface is about 50 μW/cm² and would require > five hours exposure to
33 reach 1 J/cm². The UV LED light source generates about 3 mW, the beam angle
34 was 30° so at 20 cm the UV-A radiance at the eye surface was about 33 μW/cm²
35 and would require > eight hours to reach 1 J/cm².

1 A number of types of markers 6 are suitable for use with various preferred
2 embodiments of the present invention. For example, one could use the previously
3 described array of three 1 mm x 1 mm markers 6 on a piece of plastic film 8 that is
4 affixed to the cornea of the eye. Alternatively, one could, in certain
5 circumstances, forego the use of an affixed marker array and instead tattoo or etch
6 markers 6 onto the eye.

7 The markers 6 of the present invention are chosen so as to allow for the
8 use of optical methods that increase marker signal-to-noise ratios above that of
9 corneal reflections.

10 One such technique involves using a fluorescent marker array illuminated
11 by UV-A light source. This array can be fabricated using plastic film 8 laminated
12 on paper saturated with fluorescent yellow ink. The film is opaque except for
13 three transparent 1 mm x 1 mm windows separated by 1 mm and arranged in a 45°
14 right triangle [∴]. The distance between the windows of the plastic ink backing
15 tape is fixed at 1 mm. For experiments requiring intact vision, the marker array is
16 placed away from the pupil, or on an annular contact lens 30 and is illuminated
17 with a UV-A light source. See FIG. 5.

18 Alternatively, a marker array using anti-Stokes (or 'up-converter')
19 fluorescent pigments may be used with infrared illumination. In contrast to most
20 fluorescent pigments, which can only emit wavelengths longer than those they
21 absorb, anti-Stokes pigments emit visible light under infrared illumination
22 (inorganic oxisulphide emits at 550 nm). As with the UV-fluorescent markers
23 described above, the spectral shift between the infrared illumination source and
24 the marker emissions still allows the use of optical filters to remove corneal
25 reflection artifacts. This approach has the additional benefit that the marker array
26 need not be positioned over the pupil for experiments that require absence of
27 visual input, because the infrared light sources are not visible.

28 Another marker possibility, especially suited for use with humans, is the
29 construction of a silicone scleral "contact lens" with fluorescent markers 6
30 embedded into such lens.

31 The data acquisition and analysis task of the present invention was
32 accomplished with the use of the Pentium IV 2.4 GHz 1 GB RAM computer
33 processor 32 of a desktop personal computer running Windows 2000. This
34 hardware and the appropriate software allowed binocular, three-dimensional eye
35 positions to be computed and displayed in real-time using an intuitive graphical

1 user interface 34. The LabVIEW G programming language (National Instruments,
2 Austin, TX) can be used to simplify the invention's software development.

3 The three-dimensional eye rotation necessary to move a marker array from
4 a reference position to a final position is calculated in the present invention by
5 using a mathematical method that is simpler and more efficient than others
6 previously used.

7 Assuming the eye is a sphere that rotates about its center (or more
8 precisely, that as the marker array moves with the eye, it travels along a spherical
9 surface of radius approximately equal to that defined by the eye's globe-shaped
10 outer surface), assuming the eye is centered on the camera's optical axis, and
11 defining the center of the eye as the origin of a coordinate system (i, j, k), one can
12 calculate the position in space of each marker. See FIG. 1.

13 The marker array can be positioned anywhere on the eye as long as it
14 remains visible during eye rotations. The i, j and k axes measure translation of
15 each marker in space, with j and k equaling the horizontal and vertical positions
16 of each marker (measured in pixels) from the center of the video image, and i
17 being the distance from the globe center to the marker along the optic axis of the
18 camera. The i coordinate is calculated from j and k and the known radius of the
19 eye as follows:

$$21 \quad i = \sqrt{\left((\text{eye_radius_in_pixels})^2 - (j^2 + k^2) \right)}$$

22
23 The rotation matrix \mathcal{R} uniquely describing the eye rotation required to
24 move the three markers from one position to another is:

$$27 \quad \mathcal{R} = \begin{bmatrix} i_0 & i_1 & i_2 \\ j_0 & j_1 & j_2 \\ k_0 & k_1 & k_2 \end{bmatrix}_{current} * \begin{bmatrix} i_0 & i_1 & i_2 \\ j_0 & j_1 & j_2 \\ k_0 & k_1 & k_2 \end{bmatrix}_{ref}^{-1}$$

28
29 The subscript *ref* refers to the marker position before a rotation and defines
30 the reference or zero rotational position of the eye. The subscript *current* refers to
31 the marker positions in 3-D space after a rotation. Euler angles, rotation vectors

1 and quaternions are calculated directly from the rotation matrix; see previously
2 referenced Migliaccio and Todd, 1999.

3 The steps in the above eye position calculation aspect of the present
4 invention are further illustrated in FIGS. 6a-6b. The images shown in these
5 figures were obtained from a digital camera as described herein and connected to
6 a personal computer via a IEEE1394 Firewire bus 36.

7 Using 640x 480 pixel cameras and magnification optimized so that the
8 marker array range of motion filled the camera image frame, the absolute
9 resolution of an experimental system that was assembled to demonstrate the
10 feasibility of the present invention (assuming minimum detectable image shift of
11 one pixel) was found to be $<0.2^\circ$.

12 As previously mentioned, the accuracy of the above algorithm depends on
13 alignment of the camera center with the center of the eye, which was ensured
14 using the techniques described above. If unusual circumstances dictate that the
15 camera cannot be precisely aligned with eye (e.g., in an experimental apparatus
16 with limited space for camera placement), translational and angular misalignment
17 can be corrected post hoc if the misalignment is known.

18 The correction must be in the following sequence. First, translational
19 misalignment can be corrected by redefining the image center so that rather than
20 using the default (center pixel of the camera image), the image pixel that aligns
21 with the center of rotation of the eye is defined as the origin. Second, angular
22 misalignment can be corrected by multiplying each eye rotation matrix by the
23 inverse rotation matrix describing camera rotational position in the reference
24 coordinate frame (whether head or superstructure/test-apparatus coordinates).

25 Tracking of one or more markers may be transiently lost during a blink,
26 burst of saccades or extreme eye deviation that moves the markers behind the
27 retracted eyelid or into a poorly illuminated region. Upon subsequent
28 reacquisition of the marker image, potential uncertainty exists regarding which
29 marker is which.

30 One approach to resolving this ambiguity would be to separately track
31 each marker using different colors, shapes, sizes or relative positioning in the
32 marker array. Alternatively, if the eye is assumed to stay within the $\sim 45^\circ$
33 oculomotor range, then only one of six possible permutations gives the correct
34 pairing of all three markers from one image to the next, even if intervening images
35 have been lost.

1 In experiments conducted to prove the feasibility of the present invention,
2 the correct pairing was determined by calculating the summed square of marker
3 travel distances for each permutation and accepting the permutation that resulted
4 in the smallest value. The correct permutation was always selected, regardless of
5 the cause or duration of transient marker image loss.

6 Because binocular video analysis is computationally intensive, the code
7 written for the data analysis was optimized using NI-IEEE 1394 software
8 interrupts, freeing the CPU for other processing until a new video image was
9 acquired. Camera output was time-shifted to account for the delay between image
10 acquisition at the image sensor and arrival of the new image in PC memory. This
11 delay was found to be 33.2 ± 0.1 ms by measuring the time delay between actual
12 and VOG-derived motion of a digitally-controlled motor turning a simulated eye
13 tracked by the VOG system continuously for five minutes.

14 Although the foregoing disclosure relates to preferred embodiments of the
15 invention, it is understood that these details have been given for the purposes of
16 clarification only. Various changes and modifications of the invention will be
17 apparent, to one having ordinary skill in the art, without departing from the spirit
18 and scope of the invention.

19

20

21

22

23

CLAIMS

1
2
3
4
5
6
7
8
9
10
11
12
13
14
15
16
17
18
19
20
21
22
23
24
25
26
27
28
29
30
31
32
33
34

We claim:

1. A device (1) for measuring the three-dimensional movements of an eye, said device comprising:

a means for marking an array of positions on said eye whose movements are to be measured,

a means for capturing the two-dimensional, digital images of said array of eye-marked positions as said eye is moved, said image capturing means having an optical axis and a prescribed spectral range,

a means for illuminating said marker array with a light source whose output is in a spectral range that is chosen from the group consisting of those that are either within or outside of said spectral range of said image capturing means,

a means for aligning said optical axis of said image capturing means with the center of said eye, and

a means for computing the three-dimensional locations of said array of eye-marked positions from the information contained in said captured digital images.

2. The device (1) as recited in Claim 1, further comprising a means for fixing the position of said image capturing means relative to the position of said eye whose movements are to be measured.

3. The device (1) as recited in Claim 1, wherein said alignment means including an alignment light source (20).

4. The device (1) as recited in Claim 2, wherein said alignment means including an alignment light source (20).

5. The device (1) as recited in Claim 1, wherein said array marking means including a fluorescent pigment.

6. The device (1) as recited in Claim 5, wherein said array illuminating means including an ultra-violet light source.

7. The device (1) as recited in Claim 2, wherein said array marking means including a fluorescent pigment.

8. The device (1) as recited in Claim 7, wherein said array illuminating means including an ultra-violet light source.

- 1 9. The device (1) as recited in Claim 3, wherein said array marking means
2 including a fluorescent pigment.
- 3 10. The device (1) as recited in Claim 9, wherein said array illuminating means
4 including an ultra-violet light source.
- 5 11. The device (1) as recited in Claim 1, wherein said array marking means
6 including an anti-Stokes fluorescent pigment.
- 7 12. The device (1) as recited in Claim 11, wherein said array illuminating means
8 including an infrared light source.
- 9 13. The device (1) as recited in Claim 2, wherein said array marking means
10 including an anti-Stokes fluorescent pigment.
- 11 14. The device (1) as recited in Claim 13, wherein said array illuminating means
12 including an infrared light source.
- 13 15. The device (1) as recited in Claim 3, wherein said array marking means
14 including an anti-Stokes fluorescent pigment.
- 15 16. The device (1) as recited in Claim 15, wherein said array illuminating means
16 including an infrared light source.
- 17 17. The device (1) as recited in Claim 1, wherein said means of marking an array
18 of positions on said eye whose movements are to be measured having three
19 markers (6) arranged in a 45 degree right triangle.
- 20 18. The device as recited in Claim 17, wherein said means of computing the
21 locations of said markers having an algorithm having a rotation matrix that
22 describes the eye rotation required to move said markers (6) from a first position
23 to a second position.
- 24 19. The device as recited in Claim 1, wherein said image capturing means having
25 a digital camera (2), a computer processor (32) and a high-speed interfacing
26 device that connects said camera (2) and said processor (32).
- 27 20. The device as recited in Claim 19, wherein said processor (32) being
28 configured to fit within a computer chosen from the group herein described as a
29 desktop, laptop, notebook or sub-miniature notebook.
- 30 21. A method for measuring the three-dimensional movements of an eye, said
31 method comprising the steps of:
32 marking an array of positions on said eye whose movements are to be
33 measured,
34 illuminating said marker array with a light source (12) whose output is in a
35 prescribed first spectral range,

1 aligning the optical axis of a digital camera (2) with the center of said eye,
2 using said camera (2) to capture the two-dimensional, digital images of
3 said array of eye-marked positions as said eye is moved, wherein said images are
4 captured in a spectral range that is chosen from the group consisting of those that
5 are either within or outside of said spectral range of said camera (2), and
6 computing the three-dimensional positions of said array of eye-marked
7 positions from the information contained in said captured digital images.

8 22. The method as recited in Claim 21, further comprising the step of fixing the
9 position of said camera optical axis relative to the position of said eye whose
10 movements are to be measured.

11 23. The method as recited in Claim 21, wherein said alignment step involves
12 using an alignment light source (20).

13 24. The method as recited in Claim 22, wherein said alignment step involves
14 using an alignment light source (20).

15 25. The method as recited in Claim 21, wherein said array marking step involves
16 using a fluorescent pigment.

17 26. The method as recited in Claim 25, wherein said illuminating step involves
18 using an ultra-violet light source.

19 27. The method as recited in Claim 22, wherein said array marking step involves
20 using a fluorescent pigment.

21 28. The method as recited in Claim 27, wherein said illuminating step involves
22 using an ultra-violet light source.

23 29. The method as recited in Claim 23, wherein said array marking step involves
24 using a fluorescent pigment.

25 30. The method as recited in Claim 29, wherein said illuminating step involves
26 using an ultra-violet light source.

27 31. The method as recited in Claim 21, wherein said array marking step involves
28 using an anti-Stokes fluorescent pigment.

29 32. The method as recited in Claim 31, wherein said illuminating step involves
30 using an infrared light source.

31 33. The method as recited in Claim 22, wherein said array marking step involves
32 using an anti-Stokes fluorescent pigment.

33 34. The method as recited in Claim 33, wherein said illuminating step involves
34 using an infrared light source.

1 35. The method as recited in Claim 23, wherein said array marking step involves
2 using an anti-Stokes fluorescent pigment.

3 36. The method as recited in Claim 35, wherein said illuminating step involves
4 using an infrared light source.

5 37. The method as recited in Claim 21, wherein said marking step involves using
6 three markers (6) arranged in a 45 degree right triangle.

7 38. The method as recited in Claim 37, wherein said computing step involves
8 using an algorithm having a rotation matrix that describes the eye rotation
9 required to move said markers (6) from a first position to a second position.

10 39. The method as recited in Claim 21, wherein said image capturing step
11 involves using a computer processor (32) and a high-speed interfacing device (36)
12 that connects said camera (2) and said processor (32).

13 40. The method as recited in Claim 39, wherein said image capturing step
14 involves using said computer processor (32) which is configured to fit within a
15 computer chosen from the group herein described as a desktop, laptop, notebook
16 or sub-miniature notebook.

17

18

19

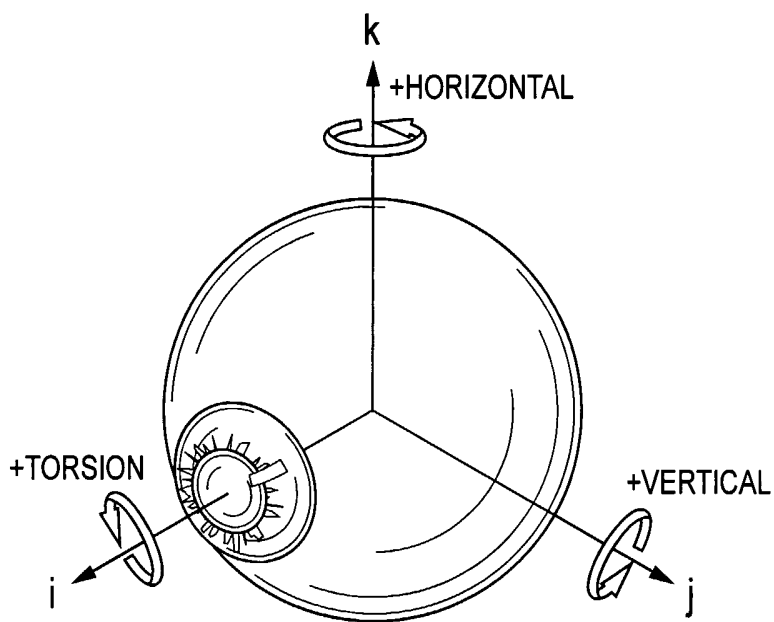

FIG. 1

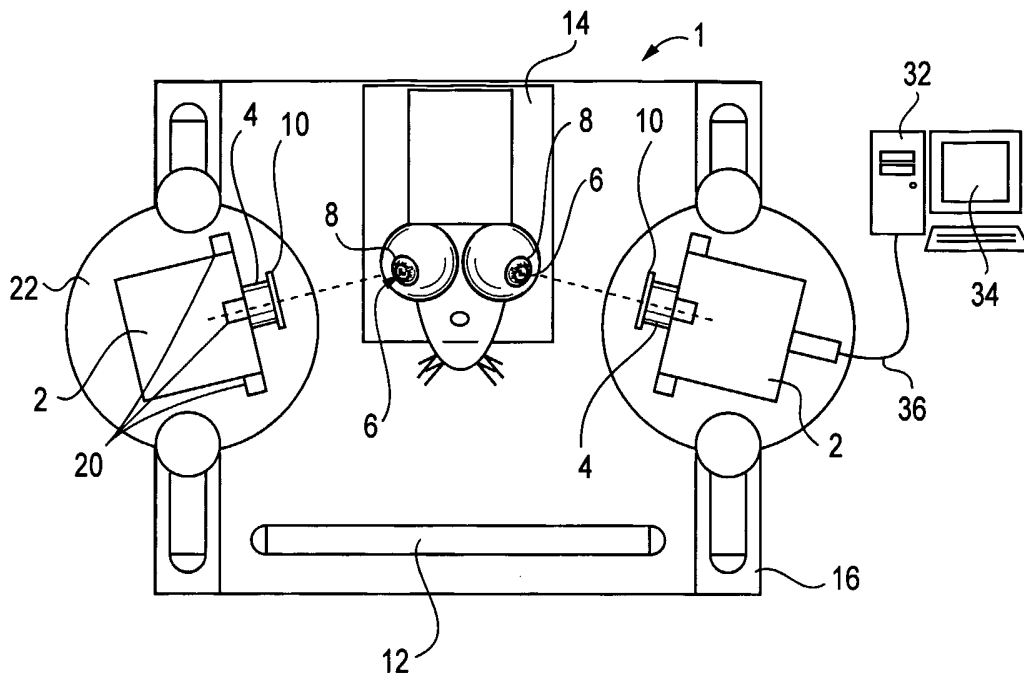

FIG. 2a

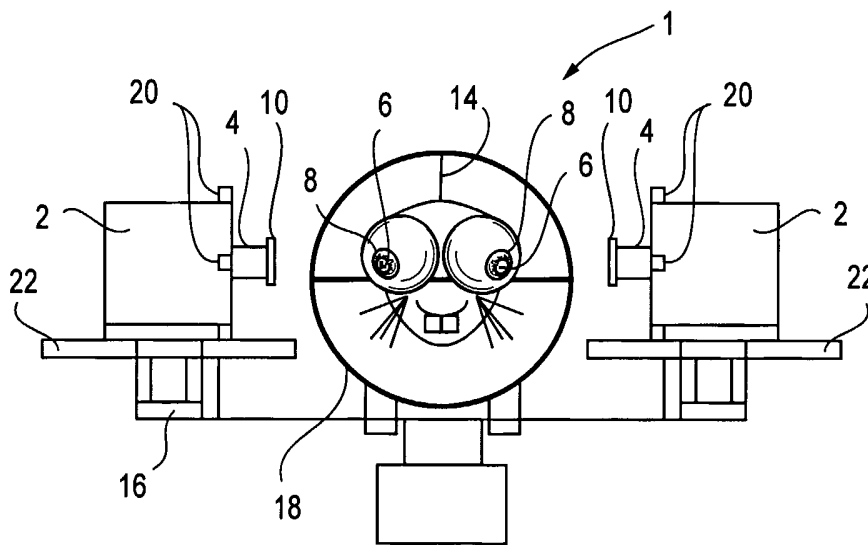

FIG. 2b

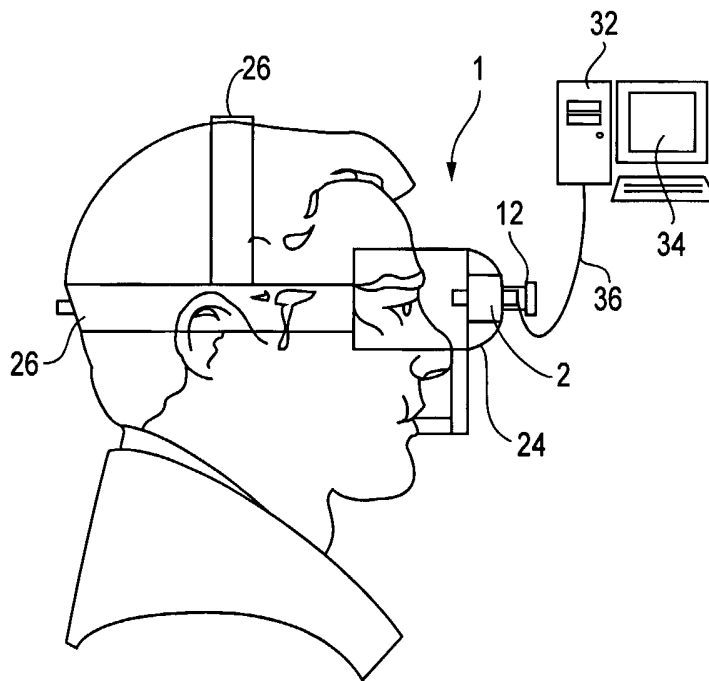

FIG. 3a

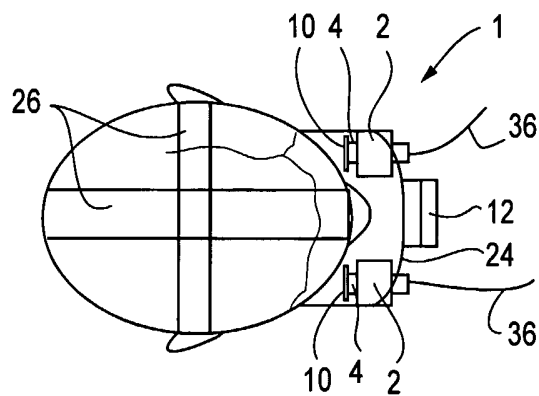

FIG. 3b

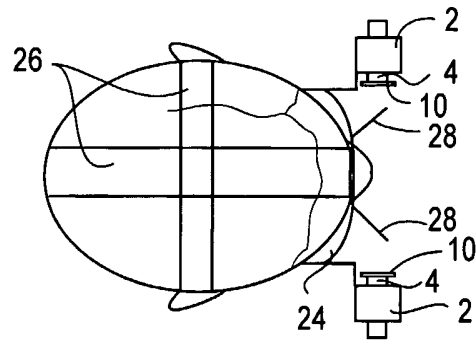

FIG. 4

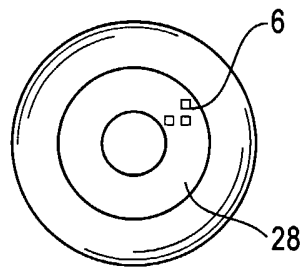
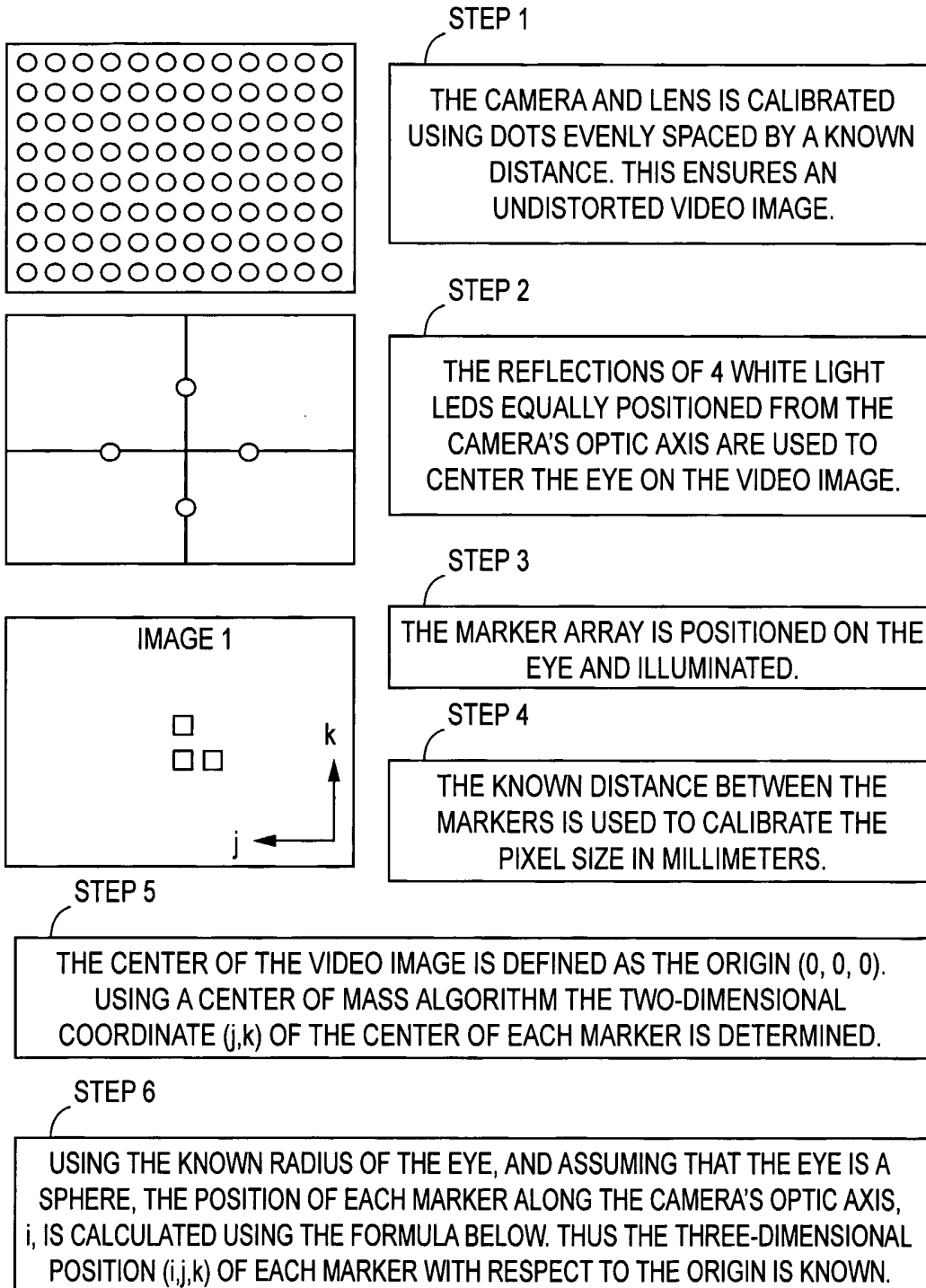

FIG. 5

5/6

FIG. 6a

STEPS IN CALCULATING EYE POSITION USING VIDEO OCULOGRAPHY



6/6

FIG. 6b

$$i = \sqrt{((eye_radius_in_pixels)^2 - (j^2 + k^2))}$$

STEP 7

ONE IMAGE IS DEFINED AS THE REFERENCE IMAGE. FOR EXAMPLE "IMAGE 1" ABOVE. THE THREE-DIMENSIONAL COORDINATES OF EACH MARKER IN THIS IMAGE DEFINE THE REFERENCE OR ZERO POSITION OF THE MARKER ARRAY (AND EYE) AND ARE USED TO CONSTRUCT THE REFERENCE POSITION ROTATION MATRIX BELOW.

$$R = \begin{bmatrix} i_0 & i_1 & i_2 \\ j_0 & j_1 & j_2 \\ k_0 & k_1 & k_2 \end{bmatrix} REFERENCE$$

STEP 8

THE THREE MARKERS IN EACH IMAGE ARE IDENTIFIED AS MARKER 0, MARKER1 OR MARKER 2. A LEAST SQUARES ALGORITHM IS USED TO ENSURE THAT EACH MARKER IS CORRECTLY IDENTIFIED AFTER TRANSIENT LOSS OF MARKER TRACKING.

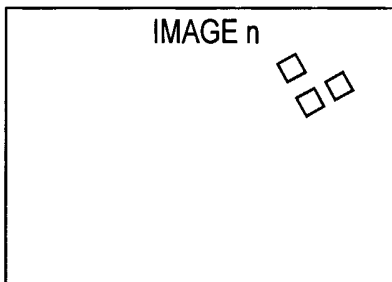

STEP 9

FOR EACH IMAGE THE THREE-DIMENSIONAL POSITION OF EACH MARKER IS CALCULATED AND USED TO CONSTRUCT A CURRENT POSITION ROTATION MATRIX .

$$R = \begin{bmatrix} i_0 & i_1 & i_2 \\ j_0 & j_1 & j_2 \\ k_0 & k_1 & k_2 \end{bmatrix} CURRENT$$

STEP 10

EYE POSITION (ROTATION MATRIX) IS DEFINED AS THE THREE-DIMENSIONAL ROTATION REQUIRED TO MOVE THE MARKER ARRAY (THREE MARKERS) FROM THE REFERENCE POSITION TO THE CURRENT POSITION.

$$R = \begin{bmatrix} i_0 & i_1 & i_2 \\ j_0 & j_1 & j_2 \\ k_0 & k_1 & k_2 \end{bmatrix} CURRENT * \begin{bmatrix} i_0 & i_1 & i_2 \\ j_0 & j_1 & j_2 \\ k_0 & k_1 & k_2 \end{bmatrix} REFERENCE^{-1}$$

STEP 11

EULER ANGLES, FICK ANGLES, HELIOHOLTZ ANGELES, ROTATION VECTORS OR QUATERNIONS CAN BE CALCULATED FROM THE EYE ROTATIONMATRIX TO DESCRIBE EYE POSITION.

INTERNATIONAL SEARCH REPORT

International Application No

PCT/US2005/003780

A. CLASSIFICATION OF SUBJECT MATTER
IPC 7 A61B3/113

According to International Patent Classification (IPC) or to both national classification and IPC

B. FIELDS SEARCHED

Minimum documentation searched (classification system followed by classification symbols)

IPC 7 A61B

Documentation searched other than minimum documentation to the extent that such documents are included in the fields searched

Electronic data base consulted during the international search (name of data base and, where practical, search terms used)

EPO-Internal, PAJ, WPI Data

C. DOCUMENTS CONSIDERED TO BE RELEVANT

Category *	Citation of document, with indication, where appropriate, of the relevant passages	Relevant to claim No.
X	WO 01/34021 A (CHRONOS VISION GMBH; CLARKE, ANDREW, A) 17 May 2001 (2001-05-17)	1,2, 17-22, 37-40
Y	column 1, line 17 - column 16, line 15; claims 1-15; figures 1-9 -----	3-16, 23-36
X	PATENT ABSTRACTS OF JAPAN vol. 2002, no. 05, 3 May 2002 (2002-05-03) & JP 2002 017677 A (HAMAMATSU PHOTONICS KK), 22 January 2002 (2002-01-22)	1-4, 17-24, 37-40
Y	the whole document -----	5-16, 25-36
Y	US 5 210 554 A (CORNSWEET ET AL) 11 May 1993 (1993-05-11) column 12, line 47 - column 15, line 9; figures 33-40 -----	3,4,23, 24
	----- -/--	

Further documents are listed in the continuation of box C.

Patent family members are listed in annex.

* Special categories of cited documents :

- "A" document defining the general state of the art which is not considered to be of particular relevance
- "E" earlier document but published on or after the international filing date
- "L" document which may throw doubts on priority claim(s) or which is cited to establish the publication date of another citation or other special reason (as specified)
- "O" document referring to an oral disclosure, use, exhibition or other means
- "P" document published prior to the international filing date but later than the priority date claimed

- "T" later document published after the international filing date or priority date and not in conflict with the application but cited to understand the principle or theory underlying the invention
- "X" document of particular relevance; the claimed invention cannot be considered novel or cannot be considered to involve an inventive step when the document is taken alone
- "Y" document of particular relevance; the claimed invention cannot be considered to involve an inventive step when the document is combined with one or more other such documents, such combination being obvious to a person skilled in the art.
- "&" document member of the same patent family

Date of the actual completion of the international search

7 June 2005

Date of mailing of the international search report

15/06/2005

Name and mailing address of the ISA

European Patent Office, P.B. 5818 Patentlaan 2
NL - 2280 HV Rijswijk
Tel. (+31-70) 340-2040, Tx. 31 651 epo nl,
Fax: (+31-70) 340-3016

Authorized officer

Birkenmaier, T

INTERNATIONAL SEARCH REPORT

International Application No
PCT/US2005/003780

C.(Continuation) DOCUMENTS CONSIDERED TO BE RELEVANT		
Category °	Citation of document, with indication, where appropriate, of the relevant passages	Relevant to claim No.
Y	US 5 678 917 A (BERGKVIST ET AL) 21 October 1997 (1997-10-21) the whole document -----	5-16, 25-36
A	WO 01/76464 A (CHRONOS VISION GMBH; CLARKE, ANDREW, A) 18 October 2001 (2001-10-18) the whole document -----	1-40

INTERNATIONAL SEARCH REPORT

Information on patent family members

International Application No

PCT/US2005/003780

Patent document cited in search report		Publication date	Patent family member(s)	Publication date
WO 0134021	A	17-05-2001	DE 19954047 A1 WO 0134021 A1 EP 1241976 A1	31-05-2001 17-05-2001 25-09-2002
JP 2002017677	A	22-01-2002	NONE	
US 5210554	A	11-05-1993	US 5042937 A US 5196872 A	27-08-1991 23-03-1993
US 5678917	A	21-10-1997	SE 505027 C2 AU 6694494 A DE 69404983 D1 DE 69404983 T2 EP 0696375 A1 FI 955126 A NO 954284 A SE 9301457 A WO 9425951 A1	16-06-1997 21-11-1994 18-09-1997 29-01-1998 14-02-1996 27-12-1995 26-10-1995 30-10-1994 10-11-1994
WO 0176464	A	18-10-2001	DE 20006333 U1 WO 0176464 A1 DE 50104229 D1 EP 1289406 A1	07-06-2001 18-10-2001 25-11-2004 12-03-2003