



- (51) International Patent Classification:
E21B 23/00 (2006.01) E21B 29/00 (2006.01)
E21B 23/08 (2006.01)
- (21) International Application Number:
PCT/US2014/019941
- (22) International Filing Date:
3 March 2014 (03.03.2014)
- (25) Filing Language: English
- (26) Publication Language: English
- (30) Priority Data:
13/784,003 4 March 2013 (04.03.2013) US
- (71) Applicant: BAKER HUGHES INCORPORATED
[US/US]; P.O. Box 4740, Houston, TX 77210 (US).
- (72) Inventors: ABDEL-BAKY, Mostafa, A.; El Razy Street,
Building Number 4, Aprt. 301, Nasr City, District 7th,
Cairo (EG). ROSENBLATT, Steve; 3600 Montrose
Boulevard, No. 502, Houston, TX 77006 (US).

(74) Agent: CARSON, Matt, W.; Baker Hughes Incorporated,
Intellectual Property Counsel, P.O.Box 4740, Houston, TX
77210-4740 (US).

(81) Designated States (unless otherwise indicated, for every
kind of national protection available): AE, AG, AL, AM,
AO, AT, AU, AZ, BA, BB, BG, BH, BN, BR, BW, BY,
BZ, CA, CH, CL, CN, CO, CR, CU, CZ, DE, DK, DM,
DO, DZ, EC, EE, EG, ES, FI, GB, GD, GE, GH, GM, GT,
HN, HR, HU, ID, IL, IN, IR, IS, JP, KE, KG, KN, KP, KR,
KZ, LA, LC, LK, LR, LS, LT, LU, LY, MA, MD, ME,
MG, MK, MN, MW, MX, MY, MZ, NA, NG, NI, NO, NZ,
OM, PA, PE, PG, PH, PL, PT, QA, RO, RS, RU, RW, SA,
SC, SD, SE, SG, SK, SL, SM, ST, SV, SY, TH, TJ, TM,
TN, TR, TT, TZ, UA, UG, US, UZ, VC, VN, ZA, ZM,
ZW.

(84) Designated States (unless otherwise indicated, for every
kind of regional protection available): ARIPO (BW, GH,
GM, KE, LR, LS, MW, MZ, NA, RW, SD, SL, SZ, TZ,
UG, ZM, ZW), Eurasian (AM, AZ, BY, KG, KZ, RU, TJ,
TM), European (AL, AT, BE, BG, CH, CY, CZ, DE, DK,
EE, ES, FI, FR, GB, GR, HR, HU, IE, IS, IT, LT, LU, LV,

[Continued on next page]

(54) Title: LINER TOP CLEANING METHOD PRIOR TO BHA REMOVAL IN DRILLING WITH ADVANCING LINER SYSTEMS

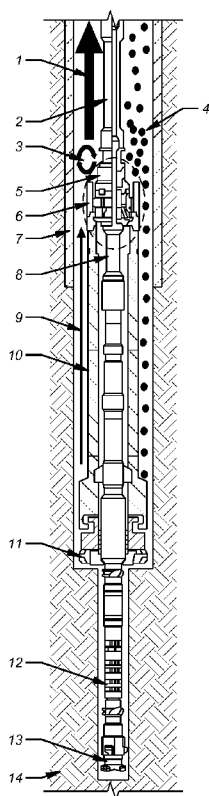

FIG. 1

(57) Abstract: In a steerable drilling liner system the liner running tools that support the bottom hole assembly have the capability of sealingly latching into the liner to allow circulation through the drill bit as the hole is made and reamed. Before removing a seal in a polished bore receptacle inside the liner, the BHA is picked up to confirm release from the liner while leaving the seal in the polished bore. Picking up a second time allows dogs to extend so that setting down weight opens a circulation port to allow debris removal from near the top of the liner along with continued circulation through the BHA. After removal of the BHA and leaving the liner in the hole, the redressed BHA with the spring loaded dogs retained enters the liner and sealingly latches to the liner so that drilling can resume.



MC, MK, MT, NL, NO, PL, PT, RO, RS, SE, SI, SK,
SM, TR), OAPI (BF, BJ, CF, CG, CI, CM, GA, GN, GQ,
GW, KM, ML, MR, NE, SN, TD, TG).

— *as to the applicant's entitlement to claim the priority of
the earlier application (Rule 4.17(iii))*

Declarations under Rule 4.17:

— *as to applicant's entitlement to apply for and be granted
a patent (Rule 4.17(ii))*

Published:

— *with international search report (Art. 21(3))*

LINER TOP CLEANING METHOD PRIOR TO BHA REMOVAL
IN DRILLING WITH ADVANCING LINER SYSTEMS

Inventor: Mostafa A. Abdel-Baky and Steve Rosenblatt

FIELD OF THE INVENTION

[0001] The field of the invention is drilling with liner and more particularly a method to allow debris removal from a liner top before pulling out the bottom hole assembly (BHA) followed by running back in with a redressed BHA and latching the liner for resumption of drilling.

BACKGROUND OF THE INVENTION

[0002] The steerable Drilling liner (SDL) system gives the operators the ability to accurately drill and log three-dimensional well profiles with a liner attached directly to the drill string. It simultaneously performs both drilling and casing operations. The goal of SDL is not only to look for trip-time savings, but also for eliminate, or at least minimize the risks of the problems associated with both drilling and casing operations.

[0003] As the drilling progresses, the drill cuttings are carried off from the bit with circulating fluid through the drill string that then takes the cuttings outside the liner. Typically, the drill bit is run in tandem with a reamer shoe to enlarge the hole beyond the pilot hole made by the bit to a larger dimension so that the liner can advance as the drill bit extends the pilot hole. There is an annular space outside the liner and the circulation of fluid with cuttings takes place in that outer annular space. At the top of the liner the flow area of the annulus increases and is defined as the annular space between the drill string and the open hole. This enlargement of the annular volume results in a notable decline in the slurry velocity with the result that some of the cuttings can no longer be carried by the flowing stream and begin to drop out on the liner top. When it later comes time to pull out the BHA after finish drilling which typically includes the drill bit, Drilling BHA and the PBR-Pack off that was seal in the polished bore receptacle at the top of the liner, pulled it out of the liner leaving open the top of the liner. This presents an opportunity for cuttings to fall into the annular space inside the liner between the inner drilling BHA and the liner inside wall. When this happens the BHA can get stuck inside the liner in the attempt to pull the BHA out of the hole.

[0004] There are some existing tools that are used to run liner into already drilled hole in conjunction with a liner hanger and a liner top packer. A packer setting dog sub is used in the string. It features a series of spring loaded dogs that are initially held retracted when the drill string is latched into the liner for delivery. After finished drilling and release liner setting tool from its sleeve. By picking up on the run in string the required distance to allow the Packer Setting Dog Sub to clear the top of the polished bore receptacle (tieback extension). When the Dog Sub clears the liner top, the spring loaded dogs will expand. Slack off onto the liner top and apply the recommended set down weight. Further this tool has an indicating mechanism that after the indicating mechanism is sheared, flow ports are opened between the drill string and annulus at the top of the packer. This allows circulation at the liner top to remove any drill cutting and/or debris from the top of the liner before pull the drilling BHA out of the hole.

More Over the tool has an unlocking feature prevents the setting dogs from expanding during the initial time that the tool is raised above the top of the polished bore receptacle extension. But when the tool re-enters the extension one more time, the setting dogs are released from unlocking sleeve, such that the next time the tool is raised above the top of the extension, the dogs will expand. This feature can help when a failure happened to the drilling BHA (inside string), pulling out of the hole with the inner drilling string is mandatory to change the failed tool, the unlocking mechanics which retract the spring loaded dogs gives the ability to run with the inside drilling BHA back inside the liner which lay down in the hole and attach the liner running tool one more time in its profile.

[0005] Those tools are offered by Baker Hughes Incorporated as the Unlocking Rotating Indicating Packer Setting Dog Sub under Product Family No. H26546 and is generally described by Baker Hughes as follows:

[0006] “The Unlocking Rotating Indicating Packer Setting (URIPS) Dog Sub is designed to apply set-down weight to compression set liner top packers. It is placed between the liner running tool and the lift sub. The unique unlocking feature prevents the setting dogs from expanding during the initial time that the tool is raised above the top of the extension. When the tool re-

enters the extension, the setting dogs are released, such that the next time the tool is raised above the top of the extension, the dogs will expand. This feature can help prevent premature activation of the setting dogs, when checking for release of the liner running tool. After the spring loaded setting dogs have been activated they can be used to transfer set down weight from the drill string to the extension of the liner top packer. The drill string can be rotated during the application of set-down weight to help work the force down to the packer. This tool has an indicating mechanism that when shear pinned for a certain load can verify that the desired force was actually applied at the packer.”

[0007] Another similar tool for the same purpose is known as the RCI Packer Setting Dog Sub and is offered by Baker Hughes Incorporated under Family Number H26545 and is generally described by Baker Hughes Incorporated as follows:

[0008] “The Rotating Circulating Indicating (RCI) Packer Setting Dog Sub is placed between the running tool and the lift sub. It is designed to apply set-down weight to compression set liner top packers. A set of spring-loaded dogs is used to transfer set-down force from the drill string to the Setting Sleeve on the liner packer. The drill string can be rotated during the application of set-down force to help work the force down to the packer. This tool has an indicating mechanism that, when shear pinned for a certain load, can ensure that a certain force was actually applied to the packer. After the indicating mechanism is sheared, flow ports are opened between the drill string and annulus at the top of the packer. This allows circulation at the liner top to remove any cement that was displaced past the liner top.”

[0009] The method of the present invention incorporates features of these tools in a very different application of running in tubular such as steerable liner while drilling. The running string supports the liner as well as a drill bit and drive motor (inner string). Liner running tool assembly allows for engagement with the liner using a latch feature such as when a replacement BHA has to be tagged into the liner left in the hole to accommodate bit replacement for example. The assembly allows release from the liner with the running string being picked up but with a seal assembly still in a polished bore

receptacle in the liner top. This way any surrounding cuttings near the liner top do not fall into the liner when picking up to be sure the BHA can freely come out of the liner. A set down force after the initial pickup force is possible because the dogs have been retained in a retracted position during the initial picking up. On subsequent setting down without allowing debris to get into the liner dog sub circulation ports are opened near the liner top as the extended dogs land on the liner top. After cleaning out the debris and cuttings near the liner top, the BHA can be pulled out of the hole (POOH) leaving the liner behind. Upon redressing the BHA and running it in the dogs are retained by a sleeve so that a latch assembly can enter the liner and advance past the PBR and latch using a collet assembly of a type known in the art. The steps can be repeated as many times as needed to get the borehole to the desired depth.

[0010] Those skilled in the art will more readily appreciate other aspects of the present invention from a review of the detailed description of the preferred embodiment and the associated drawings while recognizing that the full scope of the invention is to be found in the appended claims.

SUMMARY OF THE INVENTION

[0011] In a drilling with liner context the running tools that support the bottom hole assembly have the capability of sealingly latching into the liner to allow circulation through the drill bit as the hole is made and reamed. Before removing a seal in a polished bore receptacle inside the liner, the BHA is picked up to confirm release from the liner while leaving the seal in the polished bore. Picking up a second time allows dogs to extend so that setting down weight opens a circulation port to allow debris removal from near the top of the liner along with continued circulation through the BHA. After removal of the BHA and leaving the liner in the hole, the redressed drilling BHA and liner running tool assembly latches to the liner so that drilling can resume.

BRIEF DESCRIPTION OF THE DRAWINGS

[0012] FIG. 1 is a schematic illustration of the Steerable drilling liner and running liner BHA illustrating the problem with debris near the liner top when removing the BHA;

[0013] FIG. 2 schematic show conventional steerable drilling liner running tools;

[0014] FIG.3 schematic show steerable drilling liner running tools with the proposed tool as a solution to circulate through at the liner top;

[0015] FIG.4 is a schematic illustration of the Steerable drilling liner and running liner BHA illustrating the present invention shown in a position to remove debris before pulling the BHA from the liner;

[0016] FIG. 5 is a more detailed view of the tools show the position of the proposed or present tool at the top of the liner to circulate the drill cutting and debris before pulling the liner setting tools and the drilling BHA out of the hole and even show that the PBR-Pack off is still is the sealing area, so circulate down hole can be achieve if we keep the setting tool in tension to close the circulation ports;

[0017] FIG.6 Show the present circulation tool while the spring loaded dogs are retracted by the dogs cover sleeve

[0018] FIG.7 Show the present circulation tool 18 when the spring loaded dogs are extended and uncovered by the dogs cover sleeve

DETAILED DESCRIPTION OF THE PREFERRED EMBODIMENT

[0019] Referring to FIG. 1 a running string 5 supports a liner 10 using a releasable latching tool 16 that has releasable latching collets and a seal assembly 15 Located in a polished bore 6. A progressing cavity downhole motor drives a bit 13 to make a pilot hole that is reamed to the main bore dimension by a reamer shoe 11 that is also driven by the motor. Arrow 9 represents the circulating fluid that has passed through drill pipe, liner running tools, drill pipe inner string, drilling BHA and drill bit 13 and is headed uphole with debris 4 in the narrow annulus 9 between the outer surface of the liner 10 and the open hole borehole wall 14. Arrow 1 represents the continuing flow uphole above the upper end 6 of the liner 10. Note the accumulation of debris 4 that results from a slowdown of fluid velocity at the top of the liner as between flow at arrow 9 compared with the velocity at the arrow 1 location. Circular arrows 3 represent the eddy currents that accompany a velocity slowdown near the liner top 6 leading to significant deposits of the cuttings or debris 4 in that region. If the string 2 were to be picked up in aid of removal of

the BHA down to the drill bit **13** the debris near the top end **6** would fall into the liner **10** and stick the inner string **8** and drilling BHA **12** inside the liner.

[0020] FIG. 2 show more details about the conventional liner running tools **5** that normally used while running steerable drilling liner string, which has drill pipe to the surface **2**, PBR-pack off **15** which provide the sealing device to keep the circulation pass through the string to the drill bit **13** and ahead to the surface between the liner **10** and open hole formation **14**; and keep any debris or drilling to fall inside between liner **10** and drill pipe inner string **8**; HRD-E **16** which has collet that grips at its profile in the liner setting sleeve **6**.

[0021] FIG. 3 shows detailed view of the proposed/ presented liner setting tools **5**, the running string is omitted above the lift nipple that has an associated junk cover **17**. Junk cover **17** is intended to close the gap between liner running tools **5** and liner setting sleeve **6** inside diameter to reduce the passage of cuttings past the liner top; the proposed/ presented circulation tool **18** which has spring loaded dogs **22** retained by a dog cover sleeve **21** to allow initial entry into the liner sting sleeve **6**. With the spring loaded dogs **22** allowed to extend by virtue of relative axial movement between the dogs cover sleeve **21** and the spring loaded dogs **22** when picking up a second time as will be explained at FIG.5; HRD-E **16** which has collet that grips at its profile in the liner setting sleeve **6**.

[0022] FIG. 4 schematically illustrates the method of overcoming the problem described above using a circulating sub assembly **18** that has ports that can be opened with a set down force with the BHA supported off the liner top **6** as will be explained below. At this time the PBR-Pack off **15** is still in setting sleeve **5** so that circulation flow through openings can clear the debris or drill cuttings **4** from near the liner top **6** before the PBR-Pack off **15** is pulled out of liner setting sleeve **6**. At the same time if desired while the tool is under compression drill pipe **2**, drill pipe inner string **8**, drilling BHA **12** and drill bit **13** can rotate to decrease potentially stuck and if circulation down to the bit is required to close the upwarded circulation ports at the presented tool **18**, put the presented tool **18** in tension to close the circulation port and to circulate down the hole one more time.

[0023] FIG.5 shows the spring loaded dogs **22** after a relative axial movement between the liner sting sleeve **6** and the spring loaded dogs **22** when picking up a second time, the spring loaded dogs **22** extend such that a subsequent set down force lands the spring loaded dogs **22** on the liner setting sleeve **6** top. Further set down force creates axial component relative movement against the bias of spring **19** that opens the circulation ports **20**. As presented circulation tool **18** is in compression the circulation ports **20** will keep open, and when the presented circulation tool **18** is in tension the circulation ports **20** will close and maintained close by the action of the spring **19**.

[0024] FIG. 6 Show the present circulation tool **18** while the spring loaded dogs **22** is retracted by the dogs cover sleeve **21**

[0025] FIG.7 Show the present circulation tool **18** when the spring loaded dogs **22** is extended and uncovered by the dogs cover sleeve **21**

The drilling and reaming position continues until the BHA needs to be removed such as for replacement of the drill bit **13**. The method of doing this is to first release the liner running tools **5** from the liner setting sleeve **6** with a pick up force that still leaves the PBR-Pack off **15** in its associated seal bore liner setting sleeve **6**. With the release of liner running tools **5** from the liner setting sleeve **6** confirmed, weight is set down then by the second raising motion allows the dogs cover sleeve **21** to move axially relative to the spring loaded dogs **22** so that pulling the spring loaded dogs **22** above the liner setting sleeve top **6** will extend them. Throughout these axial movements the PBR-pack off **15** has remained in the liner setting sleeve seal bore **6** so that no cuttings can fall into the liner top. Weight is then set down on the extended spring loaded dogs **22** now supported at liner setting sleeve top **6** with the liner resting on hole bottom of the open hole bore **14**. The spring **19** is compressed and the circulation ports **20** are opened so that circulation can remove the debris and drill cutting **4** near the liner setting sleeve top **6**. When that cleaning up is concluded the BHA is POOH. The components needing replacement are replaced and the BHA is run in the hole with the spring loaded dogs **22** retained by doges cover sleeve **21** to the point where collet latch in its profile as the PBR- pack off aligns with the polished bore as illustrated in the FIG. 3

position. Pumping from the surface operates the downhole motor and rotates the bit and reamer, which, combined with setting down weight allows more hole to be drilled.

[0026] The ports **20** can have telescoping assemblies that are spring retracted and driven out by pressure that drives the fluid flow. The openings can be skewed to add a spin to the cleaning flow while the telescoping members extend the reach of the cleaning flow.

[0027] The above description is illustrative of the preferred embodiment and many modifications may be made by those skilled in the art without departing from the invention whose scope is to be determined from the literal and equivalent scope of the claims below:

We claim:

1. A method of drilling while advancing a tubular in the drilled hole, comprising:
 - running the tubular with a BHA while making more hole and advancing the tubular;
 - selectively opening at least one opening;
 - cleaning away debris accumulated near an upper end of the tubular with flow through said opening with said BHA sealingly engaged internally of the tubular;
 - removing the BHA from the tubular after said cleaning away.
2. The method of claim 1, comprising:
 - engaging said upper end of said tubular with a component of said BHA;
 - setting down weight on the tubular to selectively open said opening.
3. The method of claim 2, comprising:
 - engaging said upper end of said tubular with radially biased dogs;
 - selectively retaining said dogs retracted to the BHA with a retainer.
4. The method of claim 3, comprising:
 - moving said BHA relative to said tubular while retaining said dogs retracted to said BHA.
5. The method of claim 4, comprising:
 - picking up said BHA a first time to confirm release from the tubular without extending said dogs and while maintaining said BHA in a sealing relation to the tubular.
6. The method of claim 5, comprising:
 - setting down and picking up said BHA after confirming said release from the tubular;
 - removing said retractor from said dogs to allow said dogs to be radially outwardly biased when said picking up brings said dogs out of the tubular.
7. The method of claim 6, comprising:
 - setting down weight on said dogs when supported on the tubular to open said at least one opening.

8. The method of claim 7, comprising:
overcoming a bias with said setting down to open said at least one opening.
9. The method of claim 8, comprising:
closing said at least one opening with said bias by picking up said BHA.
10. The method of claim 7, comprising:
providing a plurality of circumferentially spaced ports as said at least one port.
11. The method of claim 10, comprising:
providing an uphole orientation for said ports.
12. The method of claim 10, comprising:
providing a tangential orientation for said ports.
13. The method of claim 10, comprising:
providing a telescoping passage associated with at least one said port.
14. The method of claim 13, comprising:
actuating said passage to extend with flow therethrough;
retracting said passage with a bias that previously was overcome with said flow therethrough.
15. The method of claim 1, comprising:
redressing said BHA after said removal from the tubular to a surface location;
retaining radially biased dogs retracted with a retainer while rerunning the redressed BHA into the tubular.
16. The method of claim 15, comprising:
latching said redressed BHA to the tubular and sealingly engaging the tubular by entering a polished bore in the tubular with a seal assembly;
resuming drilling more hole.
17. The method of claim 1, comprising:
supporting the tubular with said BHA for relative or tandem rotation;
providing a drill bit and a reamer to enlarge the hole made by said bit to allow the tubular to advance as more hole is made;

driving said bit and said reamer with a downhole motor disposed within the tubular as more hole is drilled.

18. The method of claim 17, comprising:

providing a dog sub with selectively extending dogs for supporting said BHA on the tubular;

setting down weight on the tubular with said dogs extended to open said at least one opening.

19. The method of claim 18, comprising:

providing a seal bore in the tubular;

providing a sealing element to selectively engage said seal bore;

maintaining said sealing element in contact with said seal bore while moving said BHA axially to extend said dogs.

20. The method of claim 1, comprising:

rotating said at least one opening when flowing through said at least one opening.

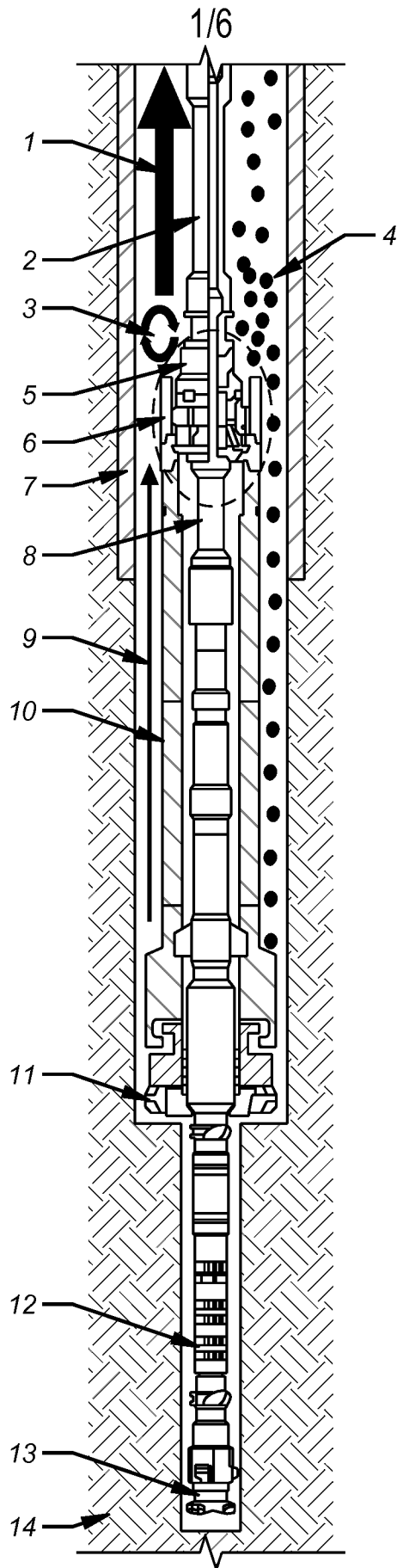

FIG. 1

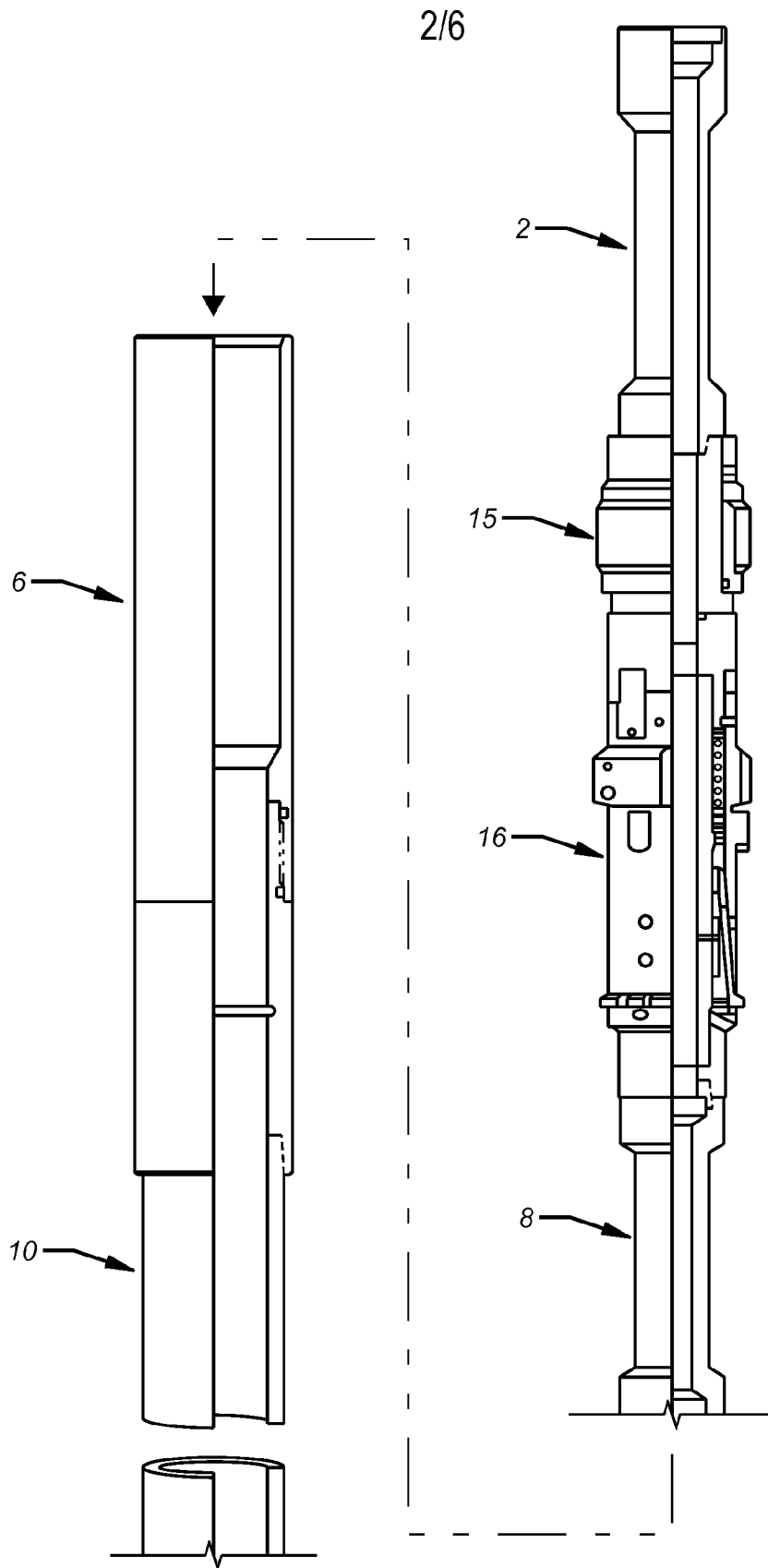

FIG. 2

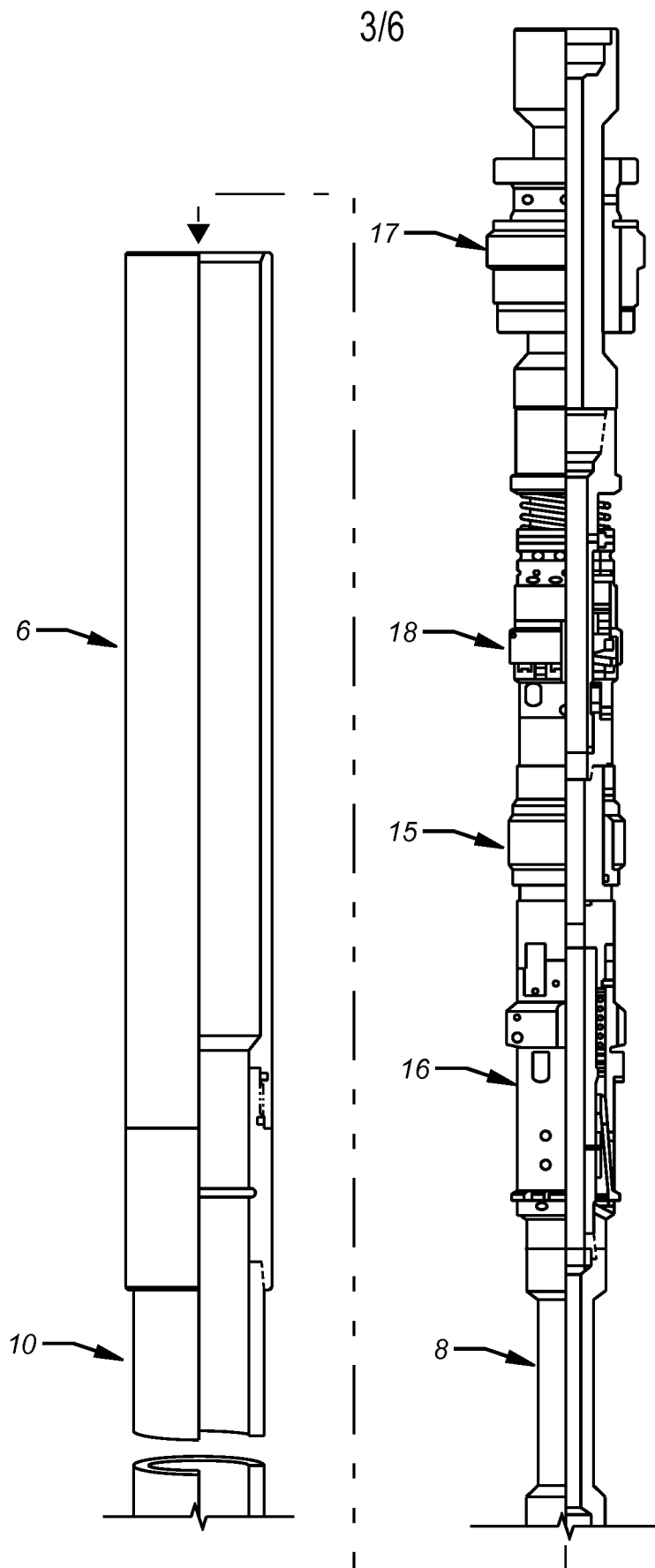

FIG. 3

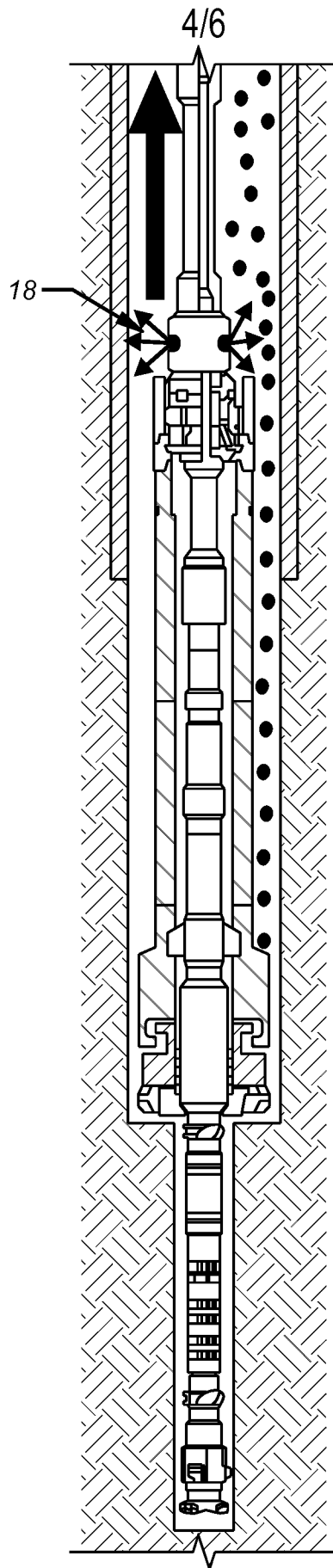

FIG. 4

5/6

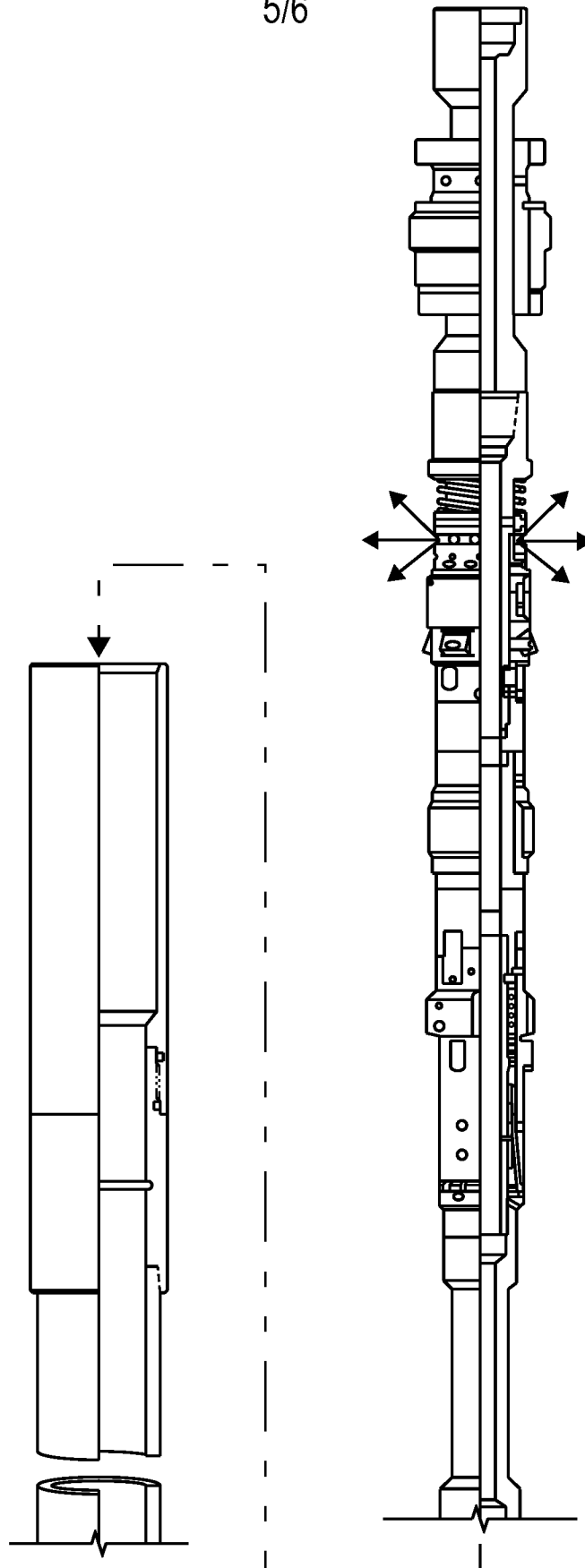

FIG. 5

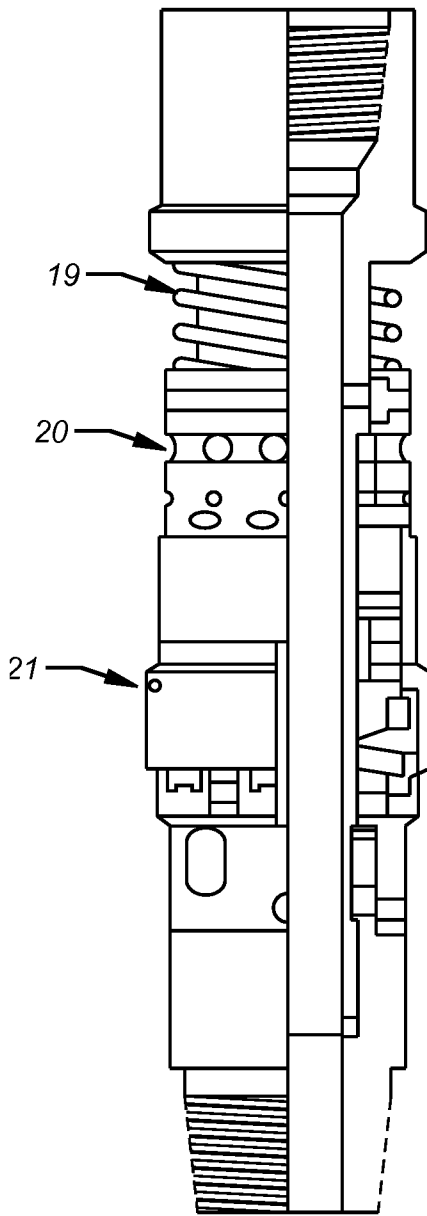

FIG. 6

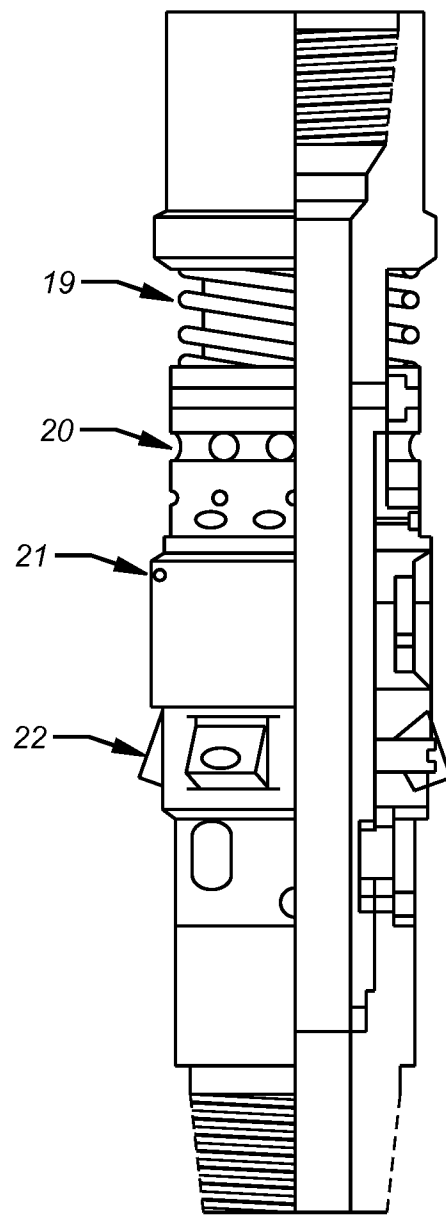

FIG. 7

A. CLASSIFICATION OF SUBJECT MATTER**E21B 23/00(2006.01)i, E21B 23/08(2006.01)i, E21B 29/00(2006.01)i**

According to International Patent Classification (IPC) or to both national classification and IPC

B. FIELDS SEARCHEDMinimum documentation searched (classification system followed by classification symbols)
E21B 23/00; E21B 34/00; E21B 37/02; E21B 29/06; E21B 29/00; E21B 43/10; E21B 23/08Documentation searched other than minimum documentation to the extent that such documents are included in the fields searched
Korean utility models and applications for utility models
Japanese utility models and applications for utility modelsElectronic data base consulted during the international search (name of data base and, where practicable, search terms used)
eKOMPASS(KIPO internal) & keywords: debris, cuttings, clean, liner, port, telescoping, replace and bottom hole assembly**C. DOCUMENTS CONSIDERED TO BE RELEVANT**

Category*	Citation of document, with indication, where appropriate, of the relevant passages	Relevant to claim No.
X	US 6408945 B1 (TELFER, GEROGE) 25 June 2002 See abstract, column 3, lines 34-37, column 5, line 6 - column 6, line 11 and figures 1, 3A-3C.	1-12, 20
Y		13-19
Y	US 5445220 A (GUREVICH et al.) 29 August 1995 See abstract, column 4, line 67 - column 5, line 62, column 6, lines 52-57 and figures 2, 4.	13, 14
A		1-12, 15-20
Y	US 2010-0282463 A1 (BOYLE, JOHN) 11 November 2010 See abstract, paragraphs [0021], [0030]-[0032] and figures 1-3.	15-19
A		1-14, 20
A	US 2007-0039737 A1 (TELFER, GEORGE) 22 February 2007 See abstract and paragraphs [0021]-[0027].	1-20
A	US 5282509 A (SCHURR, III, HARRY W.) 01 February 1994 See abstract, column 2, lines 10-67 and figures 1-6.	1-20

 Further documents are listed in the continuation of Box C. See patent family annex.

* Special categories of cited documents:

"A" document defining the general state of the art which is not considered to be of particular relevance

"E" earlier application or patent but published on or after the international filing date

"L" document which may throw doubts on priority claim(s) or which is cited to establish the publication date of another citation or other special reason (as specified)

"O" document referring to an oral disclosure, use, exhibition or other means

"P" document published prior to the international filing date but later than the priority date claimed

"T" later document published after the international filing date or priority date and not in conflict with the application but cited to understand the principle or theory underlying the invention

"X" document of particular relevance; the claimed invention cannot be considered novel or cannot be considered to involve an inventive step when the document is taken alone

"Y" document of particular relevance; the claimed invention cannot be considered to involve an inventive step when the document is combined with one or more other such documents, such combination being obvious to a person skilled in the art

"&" document member of the same patent family

Date of the actual completion of the international search

13 June 2014 (13.06.2014)

Date of mailing of the international search report

16 June 2014 (16.06.2014)

Name and mailing address of the ISA/KR

International Application Division
Korean Intellectual Property Office
189 Cheongsu-ro, Seo-gu, Daejeon Metropolitan City, 302-701,
Republic of Korea

Facsimile No. +82-42-472-7140

Authorized officer

JEONG, A Ram

Telephone No. +82-42-481-3388



INTERNATIONAL SEARCH REPORT

Information on patent family members

International application No.

PCT/US2014/019941

Patent document cited in search report	Publication date	Patent family member(s)	Publication date
US 6408945 B1	25/06/2002	AU 1998-71498 A	26/08/1998
		AU 56714 B2	22/02/2001
		CA 2280034 A1	13/08/1998
		CA 2280034 C	25/10/2005
		DE 69805161 D1	06/06/2002
		EP 0960263 A2	10/04/2002
		EP 0960263 A2	01/12/1999
		EP 0960263 B1	02/05/2002
		NO 316466 B1	26/01/2004
		NO 993500 A	04/10/1999
		NO 993500 D0	15/07/1999
		WO 98-35131 A2	13/08/1998
		WO 98-35131 A3	19/11/1998
		US 5445220 A	29/08/1995
US 2010-0282463 A1	11/11/2010	CA 2761019 A1	11/11/2010
		CO 6470856 A2	29/06/2012
		GB 201118983 D0	14/12/2011
		GB 2482088 A	18/01/2012
		GB 2482088 B	12/06/2013
		MX 2011011867 A	08/05/2012
		NO 20111620 A	24/11/2011
		US 8439113 B2	14/05/2013
		WO 2010-127454 A1	11/11/2010
US 2007-0039737 A1	22/02/2007	GB 0306821 D0	30/04/2003
		GB 0519327 D0	02/11/2005
		GB 2414758 A	07/12/2005
		GB 2414758 B	18/07/2007
		GB 2433079 A	13/06/2007
		US 2009-0255665 A1	15/10/2009
		US 7559374 B2	14/07/2009
		US 7870897 B2	18/01/2011
		WO 2004-085787 A2	07/10/2004
		WO 2004-085787 A3	07/04/2005
US 5282509 A	01/02/1994	None	