



(51) International Patent Classification:

A61B 17/072 (2006.01) A61B 34/30 (2016.01)  
A61B 17/29 (2006.01) A61B 34/00 (2016.01)  
A61B 17/28 (2006.01) A61B 17/00 (2006.01)

(21) International Application Number:

PCT/US2019/066530

(22) International Filing Date:

16 December 2019 (16.12.2019)

(25) Filing Language:

English

(26) Publication Language:

English

(30) Priority Data:

62/783,429 21 December 2018 (21.12.2018) US

(71) Applicant: **INTUITIVE SURGICAL OPERATIONS, INC.** [US/US]; 1020 Kifer Road, Sunnyvale, California 94086 (US).

(72) Inventors: **WIXEY, Matthew**; 3200 Zanker Road, Unit 1422, San Jose, California 95134 (US). **PATEL, Atal**; 21355 Longleaf, Mission Viejo, California 92692 (US). **JASEMIAN, Babak D.**; 8 Springside, Trabuco Canyon, California 92679 (US). **RAGOSTA, Nicholas**; 924 Potrero Avenue, San Francisco, California 94110 (US).

(74) Agent: **FARBER, Mark et al.**; 4 Corporate Drive, Suite 287, Shelton, Connecticut 06484 (US).

(81) Designated States (unless otherwise indicated, for every kind of national protection available): AE, AG, AL, AM, AO, AT, AU, AZ, BA, BB, BG, BH, BN, BR, BW, BY, BZ, CA, CH, CL, CN, CO, CR, CU, CZ, DE, DJ, DK, DM, DO, DZ, EC, EE, EG, ES, FI, GB, GD, GE, GH, GM, GT, HN,

(54) Title: SURGICAL INSTRUMENTS HAVING MECHANISMS FOR IDENTIFYING AND/OR DEACTIVATING STAPLER CARTRIDGES

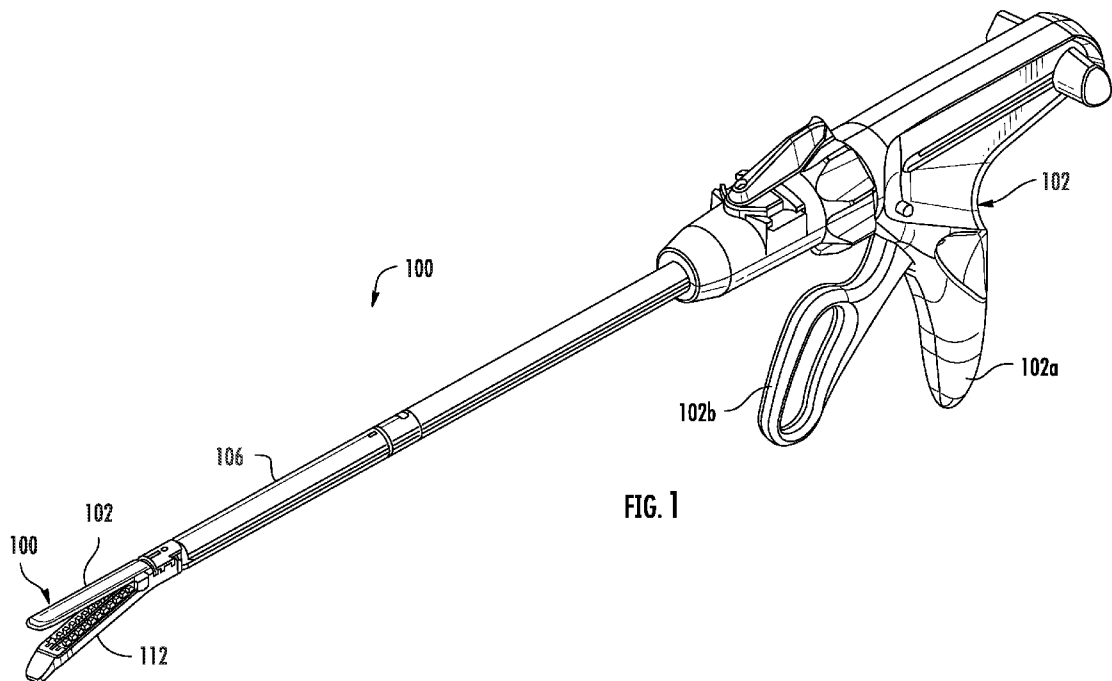

FIG. 1

(57) Abstract: Surgical stapling instruments include mechanisms for identifying and/or deactivating stapler cartridges for use with the instruments. The stapling instrument includes a drive member for actuating a staple cartridge and a locking member movable from a disabled position permitting distal translation of the drive member through a staple firing stroke, to a locking position inhibiting distal translation of the drive member through the staple firing stroke. The staple cartridge may include a switch movable in a lateral direction to either maintain the locking member in the disabled position or to allow the locking member to move into the locking position. The instrument may further include a stapler cartridge including an annular pin configured to be engaged by a drive member at an axial position to create a detectable resistance for reload detection by a control unit to identify the type of stapler cartridge present in the surgical stapling instrument.



HR, HU, ID, IL, IN, IR, IS, JO, JP, KE, KG, KH, KN, KP, KR, KW, KZ, LA, LC, LK, LR, LS, LU, LY, MA, MD, ME, MG, MK, MN, MW, MX, MY, MZ, NA, NG, NI, NO, NZ, OM, PA, PE, PG, PH, PL, PT, QA, RO, RS, RU, RW, SA, SC, SD, SE, SG, SK, SL, SM, ST, SV, SY, TH, TJ, TM, TN, TR, TT, TZ, UA, UG, US, UZ, VC, VN, ZA, ZM, ZW.

**(84) Designated States** (*unless otherwise indicated, for every kind of regional protection available*): ARIPO (BW, GH, GM, KE, LR, LS, MW, MZ, NA, RW, SD, SL, ST, SZ, TZ, UG, ZM, ZW), Eurasian (AM, AZ, BY, KG, KZ, RU, TJ, TM), European (AL, AT, BE, BG, CH, CY, CZ, DE, DK, EE, ES, FI, FR, GB, GR, HR, HU, IE, IS, IT, LT, LU, LV, MC, MK, MT, NL, NO, PL, PT, RO, RS, SE, SI, SK, SM, TR), OAPI (BF, BJ, CF, CG, CI, CM, GA, GN, GQ, GW, KM, ML, MR, NE, SN, TD, TG).

**Declarations under Rule 4.17:**

- *as to the identity of the inventor (Rule 4.17(i))*
- *as to applicant's entitlement to apply for and be granted a patent (Rule 4.17(ii))*

**Published:**

- *with international search report (Art. 21(3))*
- *before the expiration of the time limit for amending the claims and to be republished in the event of receipt of amendments (Rule 48.2(h))*

**SURGICAL INSTRUMENTS HAVING MECHANISMS FOR IDENTIFYING  
AND/OR DEACTIVATING STAPLER CARTRIDGES**

**CROSS-REFERENCE TO RELATED APPLICATIONS**

5 [0001] This application claims the benefit of U.S. Provisional Application No. 62/783,429, filed December 21, 2018, the entire disclosure of which is incorporated herein by reference for all purposes.

**BACKGROUND**

10 [0002] The field of the present disclosure relates to medical instruments, and more particularly to tissue sealing instruments for use in surgeries. Even more particularly, the present disclosure relates to a surgical stapling instrument having a novel switch-activated lockout mechanism to prevent firing of a surgical stapling instrument while a spent stapler cartridge remains in place on the jaw. The present disclosure further relates to a surgical  
15 stapling instrument including a reload detection mechanism.

[0003] Minimally invasive medical techniques are intended to reduce the amount of extraneous tissue that is damaged during diagnostic or surgical procedures, thereby reducing patient recovery time, discomfort, and deleterious side effects. One effect of minimally invasive surgery, for example, is reduced post-operative hospital recovery times.  
20 The average hospital stay for a standard open surgery is typically significantly longer than the average stay for an analogous minimally invasive surgery (MIS). Thus, increased use of MIS could save millions of dollars in hospital costs each year. While many of the surgeries performed each year in the United States could potentially be performed in a minimally invasive manner, only a portion of the current surgeries uses these advantageous  
25 techniques due to limitations in minimally invasive surgical instruments and the additional

surgical training involved in mastering them.

[0004] Improved surgical instruments such as tissue access, navigation, dissection and sealing instruments have enabled MIS to redefine the field of surgery. These instruments allow surgeries and diagnostic procedures to be performed with reduced  
5 trauma to the patient. A common form of minimally invasive surgery is endoscopy, and a common form of endoscopy is laparoscopy, which is minimally invasive inspection and surgery inside the abdominal cavity. In standard laparoscopic surgery, a patient's abdomen is insufflated with gas, and cannula sleeves are passed through small (approximately one-half inch or less) incisions to provide entry ports for laparoscopic instruments.

10 [0005] Laparoscopic surgical instruments generally include an endoscope (e.g., laparoscope) for viewing the surgical field and tools for working at the surgical site. The working tools are typically similar to those used in conventional (open) surgery, except that the working end or end effector of each tool is separated from its handle by an extension tube (also known as, e.g., an instrument shaft or a main shaft). The end effector can include,  
15 for example, a clamp, grasper, scissor, stapler, cautery tool, linear cutter, or needle holder.

[0006] To perform surgical procedures, the surgeon passes working tools through cannula sleeves to an internal surgical site and manipulates them from outside the abdomen. The surgeon views the procedure from a monitor that displays an image of the surgical site taken from the endoscope. Similar endoscopic techniques are employed in, for example,  
20 arthroscopy, retroperitoneoscopy, pelviscopy, nephroscopy, cystoscopy, cisternoscopy, sinoscopy, hysteroscopy, urethroscopy, and the like.

[0007] Minimally invasive telesurgical robotic systems are being developed to increase a surgeon's dexterity when working on an internal surgical site, as well as to allow a surgeon to operate on a patient from a remote location (outside the sterile field). In a  
25 telesurgery system, the surgeon is often provided with an image of the surgical site at a

control console. While viewing a three dimensional image of the surgical site on a suitable viewer or display, the surgeon performs the surgical procedures on the patient by manipulating master input or control devices of the control console, which in turn control motion of the servo-mechanically operated slave instruments.

5 [0008] The servomechanism used for telesurgery will often accept input from two master controllers (one for each of the surgeon's hands) and may include two or more robotic arms. A surgical instrument is mounted on each of the robotic arms. Operative communication between master controllers and associated robotic arm and instrument assemblies is typically achieved through a control system. The control system typically  
10 includes at least one processor that relays input commands from the master controllers to the associated robotic arm and instrument assemblies and back in the case of, for example, force feedback or the like. One example of a robotic surgical system is the DA VINCI™ system commercialized by Intuitive Surgical, Inc. of Sunnyvale, California.

[0009] A variety of structural arrangements have been used to support the surgical  
15 instrument at the surgical site during robotic surgery. The driven linkage or "slave" is often called a robotic surgical manipulator, and exemplary linkage arrangements for use as a robotic surgical manipulator during minimally invasive robotic surgery are described in U.S. Pat. Nos. 7,594,912, 6,758,843, 6,246,200, and 5,800,423, the full disclosures of which are incorporated herein by reference in their entirety for all purposes. These linkages  
20 often manipulate an instrument holder to which an instrument having a shaft is mounted. Such a manipulator structure can include a parallelogram linkage portion that generates motion of the instrument holder that is limited to rotation about a pitch axis that intersects a remote center of manipulation located along the length of the instrument shaft. Such a manipulator structure can also include a yaw joint that generates motion of the instrument  
25 holder that is limited to rotation about a yaw axis that is perpendicular to the pitch axis and

that also intersects the remote center of manipulation. By aligning the remote center of manipulation with the incision point to the internal surgical site (for example, with a trocar or cannula at an abdominal wall during laparoscopic surgery), an end effector of the surgical instrument can be positioned safely by moving the proximal end of the shaft using  
5 the manipulator linkage without imposing potentially hazardous forces against the abdominal wall. Alternative manipulator structures are described, for example, in U.S. Pat. Nos. 6,702,805, 6,676,669, 5,855,583, 5,808,665, 5,445,166, and 5,184,601, the full disclosures of which are incorporated herein by reference in their entirety for all purposes.

[0010] During the surgical procedure, the telesurgical system can provide  
10 mechanical actuation and control of a variety of surgical instruments or tools having end effectors that perform various functions for the surgeon, for example, holding or driving a needle, grasping a blood vessel, dissecting tissue, or the like, in response to manipulation of the master input devices. Manipulation and control of these end effectors is a particularly beneficial aspect of robotic surgical systems. For this reason, it is desirable to provide  
15 surgical tools that include mechanisms that provide two or three degrees of rotational movement of an end effector to mimic the natural action of a surgeon's wrist. Such mechanisms should be appropriately sized for use in a minimally invasive procedure and relatively simple in design to reduce possible points of failure. In addition, such mechanisms should provide an adequate range of motion to allow the end effector to be  
20 manipulated in a wide variety of positions.

[0011] Surgical instruments are often deployed into restrictive body cavities (e.g., through a cannula to inside the pelvis). Accordingly, it is desirable for the surgical instrument to be both compact and maneuverable for best access to and visibility of the surgical site. Known surgical instruments, however, may fail to be both compact and  
25 maneuverable. For example, known surgical instruments may lack maneuverability with

respect to multiple degrees of freedom (e.g., roll, pitch, and yaw) and associated desired ranges of motion.

[0012] Surgical clamping and cutting instruments (e.g., non-robotic linear clamping, stapling, and cutting devices, also known as surgical staplers; and electro-  
5 vessel sealing devices) have been employed in many different surgical procedures. For example, a surgical stapler can be used to resect a cancerous or anomalous tissue from a gastro-intestinal tract. Many known surgical clamping and cutting devices, including known surgical staplers, have opposing jaws that clamp tissue and an articulated knife to cut the clamped tissue.

10 [0013] Many surgical clamping and cutting instruments include an instrument shaft supporting an end effector to which a replaceable stapler cartridge is mounted. An actuation mechanism articulates the stapler cartridge to deploy staples from the stapler cartridge to staple tissue clamped between the stapler cartridge and an articulable jaw of the end effector. Different types of stapler cartridges (or reloads) can be used that have different  
15 staple lengths suitable for different tissues to be stapled.

[0014] The use of replaceable stapler cartridges does, however, give rise to some additional issues. For example, prior to use, a suitable stapler cartridge having the correct staple length should be mounted to the end effector. If a stapler cartridge having an unsuitable staple length is mistakenly mounted to the end effector, the tissue may be stapled  
20 with the unsuitable length staples if the error is not detected and corrected prior to stapling of the tissue. As another example, if a previously used stapler cartridge is not replaced with a suitable new stapler cartridge, the tissue clamped between the previously used stapler cartridge and the articulable jaw cannot be stapled due to the lack of staples to deploy. A similar problem can arise if no stapler cartridge is mounted to the end effector.

25 [0015] The potential disadvantages of firing a surgical stapling instrument while a

spent stapler cartridge remains in place on the jaw has given rise to the development of various lockout mechanisms. However, incorporating conventional lockout features typically increases the diameter of the end effector, increasing overall instrument size and making a given instrument less ideal for minimally invasive surgery.

5 [0016] Accordingly, while the new telesurgical systems and devices have proven highly effective and advantageous, still further improvements would be desirable. In general, it would be desirable to have a relatively compact mechanism in place to prevent firing of a surgical stapling instrument while a spent stapler cartridge remains in place on the jaw. In addition, it would be desirable to have a mechanism allowing a robotic or  
10 manual surgical system to detect the type of reload installed. Thus, a need exists for a reload detection mechanism that can detect: whether a stapler cartridge is mounted to the surgical instrument; whether the mounted stapler cartridge is unfired (i.e., fresh) or has already been fired; and/or the type of the mounted stapler cartridge mounted to the end effector to ensure that the mounted stapler cartridge has a suitable staple length for the tissue to be stapled.

15

### SUMMARY

[0017] The following presents a simplified summary of the claimed subject matter in order to provide a basic understanding of some aspects of the claimed subject matter. This summary is not an extensive overview of the claimed subject matter. It is intended to  
20 neither identify key or critical elements of the claimed subject matter nor delineate the scope of the claimed subject matter. Its sole purpose is to present some concepts of the claimed subject matter in a simplified form as a prelude to the more detailed description that is presented later.

[0018] The present disclosure relates to surgical stapling instruments that have  
25 devices or mechanisms for identifying and/or deactivating disposable stapler cartridges for

use with the stapling instruments. The stapling instrument includes a drive member for actuating a staple cartridge and a locking member movable from a disabled position permitting distal translation of the drive member through a staple firing stroke, to a locking position inhibiting distal translation of the drive member through the staple firing stroke.

5 The staple cartridge may include a switch, pin or other mechanism for maintaining the locking member in the disabled position. The switch may be further configured to operate as a reload detection mechanism for determining the type of reload present in the surgical stapling instrument.

[0019] In one embodiment, a surgical stapling instrument includes an end effector  
10 defining a longitudinal axis including a first jaw and a second jaw. The first jaw includes an anvil and the second jaw is configured to receive a stapler cartridge having one or more staples and a switch movably coupled to the stapler cartridge. The surgical stapling instrument further includes a drive member configured to translate distally and an actuation mechanism configured to translate the drive member distally through the end effector. The  
15 surgical stapling instrument further includes a locking member movable from a disabled position permitting distal translation of the drive member to at least an axial position wherein the drive member engages at least one of the staples, to a locking position inhibiting distal translation of the drive member to said axial position. The locking member is configured to move between the disabled and locked positions based on a lateral position  
20 of the switch.

[0020] One of the advantages of the present disclosure is that the switch can be configured to maintain the locking member in the disabled position and thus allow distal translation of the drive member to actuate the staples when the staple cartridge is fresh (i.e., not having been already fired). On the other hand, the switch can be configured to allow  
25 the locking member to move into the locking position during actuation of the staples (i.e.,

as the drive member is translated distally through the end effector). This effectively locks the instrument such that it cannot actuate a stapler cartridge that has already been fired.

[0021] In embodiments, the locking member is movable in a first lateral direction substantially perpendicular to the longitudinal axis from the disabled position to the locking position.

[0022] In embodiments, the surgical stapling instrument further includes a stapler cartridge. The switch is positioned within a slot formed on a tail portion of the staple cartridge and is movable in a lateral direction relative the longitudinal axis, from a first position wherein the switch maintains the locking member in the disabled position to a second position wherein the switch disengages the locking member.

[0023] One of the advantages of the present disclosure is that, because the switch moves laterally, it may be retained within the end effector of the surgical instrument on a side that is opposite the locking member, such that the switch and the locking member do not have to compete for space within the end effector, allowing for maintenance of reduced instrument size.

[0024] In embodiments, locking member is biased towards the locking position.

[0025] In embodiments, the locking member includes a switch contacting portion and a proximal engagement portion for obstructing the drive member when the locking member is in the second position. In embodiments, the drive member includes a knife, an inclined surface, and a chamfered surface.

[0026] In embodiments, upon distal advancement of the drive member, the chamfered surface of the drive member engages a chamfered surface of the switch while the switch is in the first position.

[0027] In embodiments, the slot formed on the tail portion of the cartridge includes series of detents formed therein. The detents are configured to provide mechanical

resistance when the drive member engages the switch.

[0028] In embodiments, the locking member pivots between the disabled position and the locking position. In embodiments, the locking member pivots about a pivot point that is laterally offset from the longitudinal axis of the end effector. In embodiments, the locking member pivots in a direction substantially perpendicular to the longitudinal axis defined by the end effector.

[0029] In embodiments, the actuation mechanism includes a coil that applies a distal force to the first portion of the drive member. In embodiments, the surgical further includes an elongated shaft. The end effector is mounted on a distal end portion of the elongated shaft. In embodiments, the surgical stapling instrument further includes an articulation mechanism configured to articulate the end effector relative to the elongate shaft.

[0030] In embodiments, the surgical stapling instrument further includes an actuator operatively connected to the actuation mechanism. In embodiments, the actuator includes a movable handle of a handle assembly provided at the proximal end portion of the surgical instrument. In embodiments, the actuator includes a control device of a robotic surgical system. In embodiments, the drive member includes a knife configured to cut tissue grasped between the first and second jaw.

[0017] In another aspect, the present disclosure relates to a surgical stapling instrument including a stapler cartridge having a switch. The surgical stapling instrument further includes an end effector defining a longitudinal axis including a first jaw and a second jaw. The first jaw includes an anvil and, the second jaw is configured to receive the stapler cartridge. The surgical stapling instrument further includes a drive member configured to translate distally through the end effector and an actuation mechanism configured to translate the drive member distally through the end effector. The drive

member is configured to contact the switch at an axial position of the drive member relative to the end effector. The switch is configured to provide a detectable resistance upon engagement of the drive member at said axial position. Thus, in accordance with the present disclosure, the detectable resistance may provide input for a reload detection mechanism that can detect: whether a stapler cartridge is mounted to the surgical instrument; whether the mounted stapler cartridge is unfired (or fresh) or has already been fired; and/or the type of the mounted stapler cartridge mounted to the end effector to ensure that the mounted stapler cartridge has a suitable staple length for the tissue to be stapled, based on the detectable resistance.

10 [0031] In embodiments, the switch is positioned within a slot formed on a tail portion of the stapler cartridge. In embodiments, the switch is made of metal.

[0032] In embodiments, the drive member includes a knife, an inclined surface, and a chamfered surface. In embodiments, upon distal advancement of the drive member, the chamfered surface of the drive member engages a chamfered surface of the switch.

15 [0033] In embodiments, the surgical instrument is operatively coupled to a surgical system including a control unit. The control unit is configured to process the detectable resistance to identify a type of reload present in the surgical stapling instrument.

[0034] In embodiments, the surgical stapling instrument further including a locking member. The switch is movable in a first lateral direction substantially perpendicular to the longitudinal axis, from a first position wherein the switch maintains the locking member in a disabled position to a second position wherein the switch disengages from the locking member.

[0035] In embodiments, wherein the slot formed on the tail portion of the cartridge includes series of detents formed therein. The detents are configured to provide mechanical resistance when the drive member engages the switch. In embodiments, the actuation

25

mechanism includes a coil that applies a distal force to the first portion of the drive member. In embodiments, the surgical stapling instrument further includes an elongated shaft, the end effector mounted on a distal end portion of the elongated shaft.

[0036] In embodiments, surgical stapling instruments in accordance with this disclosure further include an articulation mechanism configured to articulate the end effector relative to the elongate shaft. In embodiments, surgical stapling instruments further include an actuator operatively connected to the actuation mechanism. In embodiments, the actuator includes a movable handle of a handle assembly provided at the proximal end portion of the surgical instrument. In embodiments, the actuator includes a control device of a robotic surgical system. In embodiments, the drive member includes a knife configured to cut tissue grasped between the first and second jaw.

[0037] In other embodiments, the switch comprises an annular pin positioned within a channel formed in the stapler cartridge, the annular pin movable from an unraised position to a second raised position within the channel formed in the stapler cartridge. In embodiments, the channel formed in the staple cartridge includes at least one interference structure formed therein. The at least one interference structure is configured to retain the annular pin within the channel formed in the staple cartridge.

[0038] In embodiments, the annular pin includes one or more undercuts formed thereon to engage with the interference structure to retain the annular pin within the channel formed in the staple cartridge.

[0039] In embodiments, the surgical instrument is operatively coupled to a surgical system including a control unit, the control unit configured to process the detectable resistance to identify a type of reload present in the surgical stapling instrument.

[0040] In yet another aspect, the present disclosure relates to a surgical kit. The surgical kit includes a surgical instrument including an end effector defining a longitudinal

axis including a first jaw and a second jaw. The first jaw includes an anvil and, the second jaw is configured to receive a stapler cartridge. The surgical instrument further includes a drive member configured to translate distally through the end effector and an actuation mechanism configured to translate the drive member distally through the end effector. The  
5 kit further includes a stapler cartridge including a switch positioned at an axial position on the stapler cartridge. The drive member is configured to engage the switch to create a detectable resistance at the axial position.

[0018] In embodiments, the stapler cartridge of the kit is a first staple cartridge, and the kit further includes a second stapler cartridge. The second stapler cartridge includes a  
10 second switch positioned at a second axial position different than the axial position of the switch on the first staple cartridge. The drive member is configured to engage the switch to create a detectable resistance at the second axial position. A reload detection mechanism may detect whether a stapler cartridge is mounted to the surgical instrument; whether the mounted stapler cartridge is unfired (or fresh) or has already been fired; and/or the type of  
15 the mounted stapler cartridge mounted to the end effector to ensure that the mounted stapler cartridge has a suitable staple length for the tissue to be stapled, based on the detectable resistance provided for at the different axial positions of the switch.

[0041] In another aspect, the present disclosure relates to a surgical stapling instrument comprising an end effector defining a longitudinal axis including a first jaw and  
20 a second jaw. The first jaw includes an anvil. The surgical stapling instrument further includes a drive member configured to translate distally and retract proximally through the end effector and an actuation mechanism configured to translate the drive member distally through the end effector and retract the drive member proximally through the end effector. The second jaw is configured to receive a stapler cartridge having an annular pin positioned  
25 within a channel formed in the stapler cartridge. The annular pin is movable from an

unraised position to a raised position within the channel formed in the stapler cartridge.

[0042] In embodiments, the channel formed in the staple cartridge includes at least one interference structure formed therein. The interference structure is configured to retain the annular pin within the channel formed in the staple cartridge. In embodiments, the  
5 annular pin includes one or more undercuts formed thereon to engage with the interference structure to retain the annular pin within the channel formed in the staple cartridge.

[0043] In embodiments, the drive member engages the annular pin at an axial position. The annular pin is configured to provide for a detectable resistance upon engagement of the drive member at said axial position.

10 [0044] In embodiments, the surgical instrument is operatively coupled to a surgical system including a control unit, the control unit configured to process the detectable resistance to identify a type of reload present in the stapler cartridge.

[0045] In yet another aspect, the present disclosure relates to a surgical stapling instrument including a stapler cartridge having a switch. The surgical stapling instrument  
15 further includes an end effector defining a longitudinal axis including a first jaw and a second jaw. The first jaw includes an anvil and, the second jaw is configured to receive the stapler cartridge. The surgical stapling instrument further includes a drive member configured to translate distally through the end effector and an actuation mechanism configured to translate the drive member distally through the end effector. The surgical  
20 stapling instrument further includes a locking member movable from disabled position permitting distal translation of the drive member to at least an axial position where the drive member engages at least one of the staples, to a locking position inhibiting distal translation of the drive member to said axial position. The drive member is configured to contact the switch at an axial position of the drive member relative to the end effector. The switch is  
25 configured to provide a detectable resistance upon engagement of the drive member at said

axial position.

[0046] In embodiments, the switch is movable from a first position wherein the switch maintains the locking member in the disabled position to a second position wherein the switch disengages from the locking member. In embodiments, the switch is positioned  
5 within a slot formed on a tail portion of the stapler cartridge.

[0047] In other embodiments, the drive member includes a knife, an inclined surface, and a chamfered surface. In embodiments, upon distal advancement of the drive member, the chamfered surface of the drive member engages a chamfered surface of the switch while the switch is in the first position.

10 [0048] In other embodiments, the switch comprises an annular pin positioned within a channel formed in the stapler cartridge. The annular pin is movable from an unraised position to a second raised position within the channel formed in the stapler cartridge. In embodiments, the channel formed in the staple cartridge includes at least one interference structure formed therein. The interference structure is configured to retain the  
15 annular pin within the channel formed in the staple cartridge. In embodiments, the annular pin includes one or more undercuts formed thereon to engage with the interference structure to retain the annular pin within the channel formed in the staple cartridge. In embodiments, engagement of the inclined distal portion of the drive member with the annular pin creates a detectable resistance.

20 [0049] In embodiments, the surgical instrument is operatively coupled to a surgical system including a control unit, the control unit configured to process the detectable resistance to identify the reload present in the stapler cartridge.

[0050] In yet another aspect, the present disclosure relates to a surgical stapling instrument including an end effector defining a longitudinal axis including a first jaw and  
25 a second jaw. The first jaw includes an anvil and the second jaw is configured to receive a

stapler cartridge. The stapler cartridge includes a first and a second switch. The surgical stapling instrument further includes a drive member configured to translate distally through the end effector, and an actuation mechanism configured to translate the drive member distally through the end effector. The surgical stapling instrument further includes a locking member movable from disabled position permitting distal translation of the drive member to at least an axial position wherein the drive member engages at least one of the staples, to a locking position inhibiting distal translation of the drive member to said axial position. The drive member is configured to contact the first switch at an axial position of the drive member relative to the end effector. The first switch is configured to provide a detectable resistance upon engagement of the drive member at said axial position.

[0051] In embodiments, the first switch is an annular pin positioned within a channel formed in the stapler cartridge. The annular pin is movable from an unraised position to a second raised position within the channel formed in the stapler cartridge. The second switch is movable from a first position wherein the switch maintains the locking member in the disabled position to a second position wherein the switch disengages from the locking member.

### **BRIEF DESCRIPTION OF THE DRAWINGS**

[0052] The above and other aspects, features, and advantages of the present surgical instruments having a locking mechanism will become more apparent in light of the following detailed description when taken in conjunction with the accompanying drawings in which:

[0053] Fig. 1 is a perspective view of an illustrative surgical instrument having an end effector mounted to an elongated shaft, and an actuation mechanism;

25 [0054] Fig. 2 is a perspective view of the distal end portion of an illustrative

surgical instrument in accordance with the present disclosure with the jaws in the open position;

[0055] Fig. 3 is an exploded view of a cartridge configured for use with the surgical instrument of Fig. 1 including surgical fasteners, staple drivers, and a switch;

5 [0056] Fig. 4 depicts a partial top view of the end effector of a surgical stapling instrument including a lockout assembly in accordance with an embodiment of the present disclosure having an unfired reload installed;

[0057] Fig. 5 depicts a top view of a lockout assembly in accordance with the embodiment of Fig. 4 in the unlocked position;

10 [0058] Fig. 6 depicts a top view of a lockout assembly in accordance with the embodiment of Fig. 4 in the locked position;

[0059] Fig. 7 is a partial perspective view of an end effector in accordance with the embodiment of Fig. 4 including a lockout assembly in accordance with the embodiment of Fig. 5 showing a wedge of the drive member contacting a switch;

15 [0060] Fig. 8 depicts a perspective view of an illustrative drive member in accordance with the embodiment of Fig. 4;

[0061] Fig. 9 depicts a perspective view of an illustrative switch in accordance with the lockout assembly of Fig. 4;

[0062] Fig. 10 depicts a partial perspective view of an illustrative switch in accordance with the embodiment of Fig. 4 in the initial position after a fresh stapler cartridge has been installed;

[0063] Fig. 11 depicts a partial perspective view of an illustrative switch in accordance with the embodiment of Fig. 4 in the second position after engagement with a drive member;

25 [0064] Fig. 12 is a top view of an end effector in accordance with the embodiment

of Fig. 4 showing a drive member translated distally, a switch in the second position, and a locking member that is enabled;

[0065] Fig. 13 is a top view of an end effector in accordance with the embodiment of Fig. 4 showing a drive member that has been fully retracted after firing, and a locking member that is enabled;

[0066] Fig. 14 is a partial perspective side view of an end effector in accordance with the embodiment of Fig. 4 showing a drive member that has been fully retracted after firing, and a locking member that is enabled;

[0067] Fig. 15 is a partial top view of the proximal ends of a series of illustrative stapler cartridges having a switch in the initial position at various axial positions on the respective tail of each stapler cartridge;

[0068] Fig. 16 is a cross-sectional side of a two-part clevis of the surgical instrument of Fig. 1;

[0069] Fig. 17 is a perspective view of the end portion of an illustrative surgical instrument with parts removed;

[0070] Fig. 18 is a perspective view of a drive member in accordance with the illustrative surgical instrument of Fig. 1;

[0071] Fig. 19A is a cross-sectional perspective view of the actuation mechanism for a drive member in accordance with the surgical instrument of Fig. 1;

[0072] Fig. 19B is a cross-sectional side view of the actuation mechanism for a drive member in accordance with the surgical instrument of Fig. 1;

[0073] Fig. 20A shows a movable lower jaw of an illustrative surgical instrument in an open configuration;

[0074] Fig. 20B shows a movable lower jaw of an illustrative surgical instrument pivoting towards a closed position;

[0075] Fig. 20C shows a movable lower jaw of an illustrative surgical instrument in a closed position;

[0076] Fig. 21 is a partial perspective side view of an illustrative end effector of a surgical instrument having an annular pin;

5 [0077] Fig. 22 is a is a partial perspective side view of an illustrative end effector of a surgical instrument having an annular pin and a drive member positioned proximally of the annular pin;

[0078] Fig. 23 is a is a partial perspective side view of an illustrative end effector of a surgical instrument having an annular pin in an unraised position and a drive member  
10 engaging the annular pin upon being driven distally;

[0079] Fig. 24 is a is a partial perspective side view of an illustrative end effector of a surgical instrument having an annular pin in a raised position after engagement with a drive member that has been driven distally;

[0080] Fig. 25 is an enlarged view of the illustrative embodiment of Fig. 16  
15 showing a drive member engaging an annular pin in an unraised position;

[0081] Fig. 26 is an enlarged view of the illustrative embodiment of Fig. 16 showing a drive member that has engaged and moved an annular pin into the raised position;

[0082] Fig. 26A depicts a partial perspective view of a series of end effectors  
20 having installed stapler cartridges including annular pins positioned at a respective axial position within each cartridge;

[0083] Fig. 27 is a perspective view of an illustrative drive member in accordance with the embodiment of Fig. 16;

[0084] Fig. 28 is a perspective view of the illustrative end effector of Fig. 16 further  
25 including an inner wall formed within a channel to help stabilize the drive member upon

actuation;

[0085] Fig. 29 a partial perspective top view of an illustrative end effector of a surgical instrument having an annular pin and a switch-activated locking mechanism in an unlocked position;

5 [0086] Fig. 30 a partial perspective top view of an illustrative end effector of a surgical instrument having an annular pin and a switch-activated locking mechanism in a locked position;

[0087] Fig. 31 is a cross-sectional view of an illustrative end effector of a surgical instrument having an annular pin and a switch-activated locking mechanism in the  
10 unlocked position;

[0088] Fig. 32 is a cross-sectional view of an illustrative end effector of a surgical instrument having an annular pin and a switch-activated locking mechanism in the locked position;

[0089] Fig. 33 illustrates a top view of an operating room employing a robotic surgical system utilizing aspects of the present disclosure; and  
15

[0090] Fig. 34 illustrates a simplified side view of a robotic arm assembly that is usable with various aspects of the present disclosure.

### **DETAILED DESCRIPTION**

20 [0091] Particular embodiments of the present surgical instruments are described hereinbelow with reference to the accompanying drawings; however, it is to be understood that the disclosed embodiments are merely exemplary of the disclosure and may be embodied in various forms. Therefore, specific structural and functional details disclosed herein are not to be interpreted as limiting, but merely as a basis for the claims and as a  
25 representative basis for teaching one skilled in the art to variously employ the present

disclosure in virtually any appropriately detailed structure. Well-known functions or constructions are not described in detail to avoid obscuring the present disclosure in any unnecessary detail.

[0092] While the following disclosure is presented with respect to a linear surgical  
5 stapler where staples are sequentially fired, it should be understood that features of the presently described surgical instruments may be readily adapted for use in any type of surgical clamping, cutting, or sealing instruments. The surgical clamping and cutting instrument may be a minimally invasive (e.g., laparoscopic) instrument or an instrument used for open surgery.

10 [0093] Additionally, the features of the presently described surgical stapling instruments may be readily adapted for use in surgical instruments that are activated using any technique within the purview of those skilled in the art, such as, for example, manually activated surgical instruments, powered surgical instruments (e.g., electro-mechanically powered instruments), robotic surgical instruments, and the like.

15 [0094] Fig. 1 is a perspective view of an illustrative surgical instrument 100 in accordance with embodiments of the present disclosure having a handle assembly 102, and an end effector 110 mounted on an elongated shaft 106. End effector 110 includes a stationary jaw 111 and a moveable jaw 112. Handle assembly 102 includes a stationary handle 102a and a moveable handle 102b which serves as an actuator for surgical  
20 instrument 100.

[0095] In certain embodiments, handle assembly 102 may include input couplers (not shown) instead of, or in addition to, the stationary and movable handles. The input couplers provide a mechanical coupling between the drive tendons or cables of the instrument and motorized axes of the mechanical interface of a drive system. The input  
25 couplers may interface with, and be driven by, corresponding output couplers (not shown)

of a telesurgical surgery system, such as the system disclosed in U.S. Pub. No. 2014/0183244A1, the entire disclosure of which is incorporated by reference herein. The input couplers are drivingly coupled with one or more input members (not shown) that are disposed within the instrument shaft 106. The input members are drivingly coupled with the end effector 110. Suitable input couplers can be adapted to mate with various types of motor packs (not shown), such as the stapler-specific motor packs disclosed in U.S. Pat. No. 8,912,746, or the universal motor packs disclosed in U.S. Pat. No. 8,529,582, the disclosures of both of which are incorporated by reference herein in their entirety. Further details of known input couplers and surgical systems are described, for example, in U.S. Pat. No. 8,597,280, U.S. Pat. No. 7,048,745, and U.S. Pat. No. 10,016,244. Each of these patents is hereby incorporated by reference in its entirety.

[0096] Actuation mechanisms of surgical instrument 100 may employ drive cables that are used in conjunction with a system of motors and pulleys. Powered surgical systems, including robotic surgical systems that utilize drive cables connected to a system of motors and pulleys for various functions including opening and closing of jaws, as well as for movement and actuation of end effectors are well known. Further details of known drive cable surgical systems are described, for example, in U.S. Pat. No. 7,666,191 and U.S. Pat. No. 9,050,119 both of which are hereby incorporated by reference in their entireties. While described herein with respect to an instrument configured for use with a robotic surgical system, it should be understood that the wrist assemblies described herein may be incorporated into manually actuated instruments, electro-mechanical powered instruments, or instruments actuated in any other way.

[0097] Fig. 2 shows the distal end portion of surgical instrument 100, including an end effector 110 defining a longitudinal axis X-X and having a first jaw 111, a second jaw 112, a clevis 140 for mounting jaws 111, 112 to the instrument, and an articulation

mechanism, such as a wrist assembly 160 . In certain embodiments, second jaw 112 is a movable jaw configured to move from an open position to a closed position relative to first jaw 111. In other embodiments, first jaw 111 is a movable jaw configured to move between open and closed positions relative to second jaw 112. In still other embodiments, both jaws 5 111, 112 are movable relative to each other. First jaw 111 includes an anvil 115 having staple-forming pockets 116. In the exemplary embodiment, first jaw 112 is a movable jaw 112 configured to move from an open position to a closed position relative to stationary jaw 111. In the open position, a fresh stapler cartridge 122 (sometimes referred to as a fresh or unfired reload) can be loaded into movable jaw 112 and tissue may be positioned 10 between the jaws 111, 112. In the closed position, jaws 111, 112 cooperate to clamp tissue such that stapler cartridge 122 and the anvil 115 are in close cooperative alignment.

[0098] As shown in Fig. 3, stapler cartridge 122 may include a plurality of staples 124 supported on corresponding staple drivers 126 provided within respective staple retention openings 127 formed in stapler cartridge 122. As shown in Fig. 8, end 15 effector 110 may also include a drive member 150 configured to translate distally and retract proximally through the end effector, the drive member may have a shuttle 123 integrally formed thereon including an inclined distal portion 125 that sequentially acts on staple drivers 126 upon distal movement of the drive member 150, camming staple drivers 126 upwardly, thereby moving staples 124 into deforming contact with anvil 115. In 20 embodiments, shuttle 123 may be included within stapler cartridge 122 as a separate component. In embodiments, stapler cartridge 122 further includes one or more switches configured to engage a slot 196 formed on the proximal tail 195 of stapler cartridge 122. The functionality of switches 191 will be described in more detail below. As seen in Fig. 8, drive member 150 includes an upper shoe 152 that is substantially aligned with and 25 translates through a channel in fixed jaw 111 (see Fig. 2), while lower shoe 154, also seen

in Fig. 8, of drive member 150 translates through and underneath jaw 112. The details of the drive member and actuation will be described below.

[0099] Fig. 4 shows a portion of an illustrative surgical instrument with an unfired reload installed, including portions of stapler cartridge 122, a locking member 170, and  
5 switch 191.

[00100] When an unfired reload is installed, as shown in Fig. 4, switch 191 is in a first home (or default) position. In a fresh, unfired reload, switch 191 is in contact with switch engaging portion 172 of locking member 170, keeping engagement portion 174 out of channel 119. When locking member 170 is in this disabled position, distal translation of  
10 drive member 150 is permitted, as locking member 170 will not obstruct movement of drive member 150 because engagement portion 174 is held out of alignment with channel 119.

[00101] Figs. 5 and 6 show a top view of a locking assembly including a locking member 170 in the unlocked or disabled position and the locked position, respectively with switch 191 not shown.

15 [00102] Locking member 170 pivots about a pivot point 179 that is laterally offset from channel 119. Locking member 170 is configured to move in a direction substantially perpendicular to the longitudinal axis of the end effector. Spring 178 biases engagement portion 174 of locking member 170 into channel 119 to lock the instrument. In the unlocked position of Fig. 5, switch 191 (see Fig. 4) engages switch engaging portion 172 of locking  
20 member 170, overcoming the bias of spring 178 and holding engagement portion 174 out of channel 119, permitting distal movement of drive member 150. When switch 191 is no longer in contact with switch engaging portion 172 of locking member 170, spring 178 forces engagement portion 174 of locking member into channel 119 as seen in Fig. 6, where engagement portion 174 obstructs distal movement of drive member 150.

25 [00103] Fig. 7 shows a view of an end effector in accordance with the embodiment

of Fig. 4 including a lockout assembly in accordance with the embodiment of Fig. 5. In Fig. 7, a fresh reload has been installed, and switch 191 is in the initial position. Locking member 170 is held by switch 191 out of channel 119 so that, upon actuation, drive member 150 may be advanced distally along channel 119. As shown in Fig. 7, upon distal translation of drive member 150 during actuation of the instrument, a chamfered surface 131 formed on drive member 150 (as seen in Fig. 8) engages a chamfered surface 192 formed on switch 191 (as seen in Fig. 9). Switch 191 is then driven through a switch channel 129 in a direction substantially perpendicular to the longitudinal axis of end effector 110.

[00104] In Fig. 10, switch 191 is shown in the initial position within switch channel 129 (see Fig. 7). Switch channel 129 includes a series of detents 132 configured to provide mechanical resistance that must be overcome by drive member 150 in order to slide switch 191 from the initial position toward the second position, shown in Fig. 11. This ensures that the lockout will not unintentionally activate as may happen if switch 191 freely slides in channel 129 (e.g., in the absence of detents 132). In embodiments, switch 191 may be secured by friction fit within switch channel 129. As best seen in previously described Fig. 7, while drive member 150 translates distally along the longitudinal axis defined by end effector 110, switch 191 moves laterally through channel 129 in a direction perpendicular to the axis. This allows switch 191 to be retained within end effector 110 on a side that is opposite locking member 170, such that switch 191 and locking member 170 do not have to compete for space within end effector 110, allowing for maintenance of reduced instrument size.

[00105] In Fig. 12 drive member 150 has translated distally, forcing switch 191 to the second position thereby enabling locking member 170 as spring 178 biases engagement portion 174 of locking member 170 into channel 119. Drive member 150 may continue to travel distally to drive staples into tissue and cut the stapled tissue. Upon retraction, drive

member 150 engages a series of proximal ramped surfaces 176 on locking member 170, allowing drive member 150 to return to a position proximal of locking member 170. However, once drive member 150 is positioned proximally of locking member 170, if another attempt is made to actuate the instrument, drive member 150 will be obstructed by engagement portion 174 of locking member 150, preventing actuation of an unloaded instrument, as best seen in Figs. 13 and 14.

[00106] Fig. 15 shows a series of illustrative cartridges having a switch 191 in the initial position at various axial positions on the respective tail 195 of each stapler cartridge 122. In embodiments, the axial position of switch 191 may function as a mechanism by which a robotic surgical system may identify the type of stapler cartridge installed. As drive member 150 translates through the end effector, it will encounter the switch at a distinct axial position for a given type of stapler cartridge. When the drive member encounters the switch, the drive member will encounter a detectable amount of resistance. In embodiments, a robotic surgical system may be configured to detect the position along a firing stroke at which the chamfered surface 131 formed on drive member 150 engages switch 191 via detection of a torque spike, allowing the system to determine the type of stapler cartridge installed. This will allow a control unit, operatively coupled with the actuation mechanism, to determine the correct amount of forces to apply to the drive member depending upon the features of the detected type of stapler cartridge, including but not limited to, the number of staples contained therein, the size of the staples contained therein, and the geometry of the staples contained therein. An exemplary surgical stapler including a surgical system including a control unit operatively coupled to the actuation mechanism is described for example in International Application No. PCT/US2017050747, the disclosure of which is hereby incorporated by reference in its entirety.

[00107] Jaws 111, 112 are attached to surgical instrument 100 via clevis 140. See,

Fig. 16. Clevis 140 includes a proximal surface 140a and a distal surface 140b. Clevis 140 further includes upper clevis portion 142 and lower clevis portion 141 that cooperate when assembled to form protrusion 145 (see Fig. 20A) configured to engage tabs 113 (seen in in Fig. 20A of jaw 111 to securely mount jaw 111 in a fixed position on instrument 100. As  
5 seen in Fig. 16, Lower clevis portion 141 includes a pair of distally extending arms 147 for supporting movable jaw 112. Arms 147 include opening 149 for receiving a pivot pin 130 defining a pivot axis around which jaw 112 pivots as described in more detail below. Lower clevis portion 141 also includes ramped groove 144 configured to guide a portion of an actuation coil 120 (see Fig. 19A) emerging from wrist 160 (see Fig. 17). Upper clevis  
10 portion 142 includes a complementary shaped ramped groove 146 that cooperates with ramped groove 144 of lower clevis portion 141 to form an enclosed channel 180 that guides coil 120 as it jogs upwards from wrist 160 towards distal surface 157 of upper shoe 152 of drive member 150. In embodiments, channel 180 may include a first end 181 at a central portion of proximal surface 140a and a second end 182 at a peripheral portion of distal  
15 surface 140b. In embodiments, enclosed channel 180 may be substantially “S” shaped. Although shown as a two-part clevis, it should be understood that the clevis may be a unitary structure formed, for example, by molding, machining, 3-D printing, or the like.

[00108] End effector 110 may be articulated in multiple directions by an articulation mechanism. In embodiments, the articulation mechanism may be a wrist 160 as shown,  
20 although other articulation mechanisms are contemplated. As seen in Fig. 17, wrist 160 includes a plurality of articulation joints 162, 164, 166, etc. that define a bore 167 through which an actuation mechanism (in embodiments, coil 120 and drive cable 171, see Fig. 19A) may pass. Upon exiting articulation wrist 160, coil 120 enters and passes through channel 180 of clevis 140 (see Fig. 18), ultimately engaging proximal surface 153 of upper  
25 shoe 152 of drive member 150. Other articulation mechanisms within the purview of those

skilled in the art may substitute for wrist 160. One suitable articulation mechanism is described for example in U.S. Publication No. 2015/0250530, the disclosure of which is hereby incorporated by reference in its entirety.

[00109] Upon actuation of the surgical instrument, drive member 150 is advanced  
5 distally through end effector 110 to move jaws 111, 112 from the open position to the closed position, after which shuttle 123 and knife 128 are advanced distally through cartridge 122 to staple and cut tissue grasped between jaws 111, 112. Drive member 150 may be any structure capable of pushing at least one of a shuttle or a knife of a surgical stapling instrument with the necessary force to effectively sever or staple human tissue.  
10 Drive member 150 may be an I-beam, an E-beam, or any other type of drive member capable of performing similar functions. Drive member 150 is movably supported on the surgical stapling instrument 100 such that it may pass distally through cartridge 122 and upper fixed jaw 111 and lower jaw 112 when the surgical stapling instrument is fired (e.g., actuated).

[00110] As seen in Fig. 18, drive member 150 may include a body 151, upper shoe  
15 152, lower shoe 154, and central portion 156. Upper shoe 152 of drive member 150 is substantially aligned with and translates through a channel 118 in fixed jaw 111, while lower shoe 154 of drive member 150 is substantially aligned with and translates through a channel 119 and below jaw 112. Bore 158 is formed through upper shoe 152 to receive  
20 drive cable 171 as will be described in more detail below. Proximal surface 153 of upper shoe 152 is configured to be engaged by a coil 120 of actuation assembly 190 such that coil 120 may apply force to upper shoe 152 to advance drive member 150 distally, i.e., in the direction of arrow "A" in Fig. 19B. A knife 128 may be formed on drive member 150 along the distal edge between upper shoe 152 and central portion 156. In embodiments, inclined  
25 distal portions 125 may be formed on either side of drive member 150.

[00111] Actuation assembly 190 includes a drive cable 171, a coil 120, a sheath 121 surrounding coil 120, and a drive rod 175. Drive cable 171 includes an enlarged distal end 173.

[00112] As seen in Figs. 19A and 19B, upper shoe 152 of drive member 150 includes  
5 a bore 158 into which drive cable 171 is routed. When assembling illustrative surgical instrument 100, coil 120 and a protective sheath 121 are slipped over the free end of drive cable 171. The free end of drive cable 171 is attached to a drive rod 175 securing coil 120 and the protective sheath 121 between drive member 150 and drive rod 175 as seen in Fig. 19B. Sheath 121 may function to promote stability, smooth movement, and prevent  
10 buckling upon actuation of surgical instrument 100. Sheath 121 may be made from polyimide, or any other suitable material having the requisite strength requirements such as various reinforced plastics, a nickel titanium alloy such as NITINOL™, poly para-phenyleneterphtalamide materials such as KEVLAR™ commercially available from DuPont. Other suitable materials may be envisioned by those of skill in the art. Enlarged  
15 distal end 173 of drive cable 171 resides within an enlarged distal portion 159 of bore 158 in upper shoe 152 of body 150, such that the proximal face 157 of enlarged distal end 173 may apply a retraction force on upper shoe 152 when the drive cable 171 is pulled proximally, i.e., in the direction of arrow “B” in Fig. 19B. Drive rod 175 is operationally connected to an actuator (e.g., movable handle 102b), which allows distal translation and  
20 proximal retraction of actuation assembly 190. Those skilled in the art will recognize that in a manually actuated instrument, the actuator may be a movable handle, such as moveable handle 102b shown in Fig. 1; in a powered instrument the actuator may be a button (not shown) that causes a motor to act on the drive rod; and in a robotic system, the actuator may be a control device such as the control devices described below in connection with  
25 Fig. 28. Any suitable backend actuation mechanism for driving the components of the

surgical stapling instrument may be used. For additional details relating to exemplary actuation mechanisms using push/pull drive cables see, e.g., commonly owned International Application WO 2018/049217, the disclosure of which is hereby incorporated by reference in its entirety.

5 [00113] During actuation of illustrative surgical instrument 100, drive rod 175 applies force to coil 120, thereby causing coil 120 to apply force to upper shoe 152 of drive member 150, translating it distally (i.e., in the direction of arrow "A" in Fig. 19B) initially closing jaws 111,112 and then ejecting staples 124 from cartridge 122 to staple tissue. After stapling is complete, drive rod 175 applies a force in the proximal direction to effect  
10 retraction of drive member. During retraction, enlarged distal end 173 of drive cable 171 is obstructed by wall 157 of enlarged portion 159 of bore 158, causing drive cable 171 to apply force to upper shoe 152 of drive member 150, thereby translating drive member 150 in the proximal direction. In certain embodiments, the surgical instrument may be designed such that the drive member 150 is not retracted in the proximal direction after the staples  
15 have been fired. One of ordinary skill in the art will appreciate that drive member 150, drive cable 171, and drive rod 175 all move in unison and remain in the same relative position to each other.

[00114] In the preferred embodiment, drive cable 171 advances drive member 150 through fixed jaw 111 (instead of through the staple cartridge jaw as in conventional  
20 surgical stapling instruments). Eliminating the internal channel for the actuation mechanism from the staple cartridge provides more space in the cartridge for the staples and for the reinforcing wall discussed above. In alternative embodiments, coil 120 of actuation assembly 190 may be coupled with lower shoe 154 instead of upper shoe 152. In these embodiments, coil 120 applies force to lower shoe 153 to advance drive member 150  
25 distally through a channel (not shown) in the lower jaw 112. In these embodiments, coil

120 will advance at least through a portion of lower jaw 112 and staple cartridge 122.

[00115] Figs. 20A-C depict fixed jaw 111 and movable jaw 112 of illustrative surgical instrument 100 sequentially moving from an open configuration to a closed configuration. As shown in Fig. 20A, in the open configuration, drive member 150 is positioned proximally of cam surface 114 formed on movable jaw 112. As drive member 150 translates in the distal direction “A” movable jaw 112 will rotate towards the closed position around pivot 117.

[00116] In Fig. 20B, drive member 150 has come into contact with cam surface 114 of movable jaw 112. As lower portion 154 of drive member 150 rides underneath cam surface 114, drive member 150 pushes movable jaw 112, causing it to pivot towards the closed position.

[00117] Fig. 20C illustrates jaws 111, 112 in the closed position. Drive member 150 has translated distally past cam surface 114. In this position, tissue is clamped, and further advancement of the drive member will sever and staple tissue.

[00118] Fig. 21 illustrates an alternative embodiment in which an illustrative end effector 210 has a stapler cartridge 222 installed therein. Stapler cartridge 222 includes an annular pin 280 configured to be engaged by an inclined distal portion 225 of an illustrative shuttle 223. It is envisioned that shuttle 223 may be a separate component contained in stapler cartridge 222, or integrally formed on a drive member 250 as seen in Fig. 22.

[00119] Figs. 22-26 sequentially depict actuation of a surgical instrument including the illustrative end effector and reload shown in Fig. 21.

[00120] In Fig. 22, stapler cartridge 222 includes annular pin 280 in an unraised position corresponding to a freshly installed reload. Upon actuation, a drive member 250 (as shown in Fig. 27) is driven distally through end effector 210. Drive member 250 may have an integrated shuttle component 223 having inclined distal portions 225 attached

thereto. In Fig. 23, an inclined distal portion 225 of shuttle 223 engages a lower ramped portion 282 of annular pin 280 applying sufficient force to cause annular pin 280 to be pushed through a cartridge channel 290 towards a raised position.

[00121] In Fig. 24, drive member 250 has translated distally such that shuttle 223  
5 has fully engaged and moved annular pin 280 into the raised position. When annular pin 280 is in the raised position, drive member 250 may pass under annular pin 280 to continue to translate distally to sequentially fire staples and cut tissue.

[00122] Figs. 25 and 26 show the mechanism by which annular pin 280 is retained  
10 within cartridge 222 once moved into the raised position. Annular pin 280 may have one or more undercuts 284 formed on either side of annular pin 280. In embodiments, annular pin 280 may include an upper undercut 285, a middle undercut 286, and a lower undercut 287. Before being contacted by inclined distal portion 225, annular pin 280 is retained within cartridge channel 290 by engagement of the upper undercut 285 with an upper edge 293 of an interference ring 295 formed within cartridge channel 290. In embodiments, any  
15 interferences structure of a suitable shape or size may be used to retain annular pin 280 in channel 290. Channel 281 may include one or more interference rings 295 as desired. In Fig. 20, as inclined distal portion 225 urges annular pin 280 upwards, an amount of force is needed to push middle undercut 286 upward with enough force to be driven past a lower edge 292 of interference ring 295.

20 [00123] In Fig. 26, annular pin 280 has been moved into the raised position in which middle undercut 286 is now above and resting on upper edge 293 of interference ring 295, retaining annular pin 280 within cartridge channel 290 out of the path of shuttle 223 of drive member 250.

[00124] In embodiments, robotic surgical system may be configured to detect the  
25 position along a firing stroke at which the inclined distal portion 225 of shuttle 223 engages

annular pin 280 via detection of a torque spike, allowing the system to determine the type of reload presently installed. Based on the detected torque spike, a control unit, operatively coupled with the actuation mechanism, may read and process the detectable force to determine the correct amount of force to apply to the drive member in a similar fashion as described above in connection with previously described embodiments. In embodiments, the position of the annular pin and the position of channel 291 and its associated retention features may be moved proximally within different types of reload configured to be installed within cartridge 222 to provide for a unique contact point between annular pin 280 and inclined distal portion 225 as best seen in Fig. 26A. Thus, a surgical system may identify the detectable force at a different axial position along the firing stroke, thus allowing the system to differentiate between different types of reloads installed in a given cartridge 222 based on the position of annular pin 280. It is envisioned that drive member 250 may include any structure capable of engaging annular pin 280 at a given axial position to create a detectable resistance, so long as the accompanying interference structure described above is modified to complement the direction in which annular pin 280 is driven upon engagement by drive member 250. It is also envisioned that an annular pin may engage and maintain a locking member in a disabled position in a similar manner as switch 191 described in connection with previous embodiments in a first position, and may then disengage with the locking member upon actuation to allow the locking member to pivot to a locked position, prevent actuation in the presence of a spent cartridge. Figs. 27 and 28 illustrate a feature for stabilizing drive member 250 upon actuation of a surgical instrument including an annular pin 280. As inclined distal portion 225 engages annular pin 280 as described above, shuttle 223 and drive member 250 experience a downward force that causes shuttle 223 to deflect away from annular pin 280. When drive member 250 and shuttle 223 experience vertical load, a protrusion 255 formed on shuttle 223 pushes against

an inner wall 221 formed within a channel of jaw member 211 (above lower shoe 254) providing a counter force. Inner wall 221 and the counter force it provides reduces the deflection of shuttle 223 and drive member 250, ensuring more controlled engagement between annular pin 280 and shuttle 223 and limiting potential stress or damage to drive member 250 from excessive deflection or bending.

[00125] In embodiments, an illustrative end effector 210 may include both an annular pin 280 for reload detection, and a switch 261 for engaging a locking member 270. In Figs. 29 and 30, an illustrative end effector 210 including an annular pin 280 on one side of a stapler cartridge 222, and a switch 261 on the opposing side of stapler cartridge 222.

10 Annular pin 280 functions as described above in connection with Figs. 24-26. In Fig. 29, a locking member 270 includes an engagement portion 274 that is being held out of channel 219 through which drive member 250 travels distally. A spring 278 biases locking member 270 towards channel 219, however, switch 261 engages a distal portion 272 of locking member 270, retaining the proximal engagement portion out of alignment with channel

15 219. Fig. 30 depicts locking member 270 with engagement portion 274 protruding into channel 219 to obstruct drive member 250 after actuation of the instrument. Switch 261 has been moved into a raised position, and distal portion 272 of locking member has now moved out of channel 219 towards a position below switch 261, thereby causing engagement portion 274 to translate towards channel 219. In this configuration, an attempt

20 to actuate the instrument again would cause drive member 250 to be obstructed by engagement portion 274 of lock 270.

[00126] Figs. 31 and 32 show cross sectional views depicting actuation within the end effector of Figs. 29 and 30.

[00127] In Fig. 31, drive member 250 is able to translate through channel 219 (as seen in Fig. 30) unobstructed, as locking member 270 is being held out of engagement with

channel 219 by switch 261 as it sits in the unraised position. Fig. 31 further shows inclined distal portion 225 aligned with, and about to engage, a cutout 262 formed on switch 261. In Fig. 32, switch 261 has been driven to the raised position, allowing distal portion 272 of locking member 270 to swing underneath switch 261, causing the proximal engagement portion 274 of locking member 270 to swing in an opposing direction towards channel 219. Should a user retract drive member 250 and attempt to actuate the surgical instrument, engagement portion 274 (now aligned with drive member 250 within channel 219) of locking member 270 would obstruct drive member 250 and prevent cutting of tissue or firing of staples.

10 [00128] In embodiments, surgical instruments in accordance with this disclosure may alternatively include switches configured to be sheared along an axis, or switches having vertical cutouts designed to be engaged by an inclined distal portion of a drive member for purposes of engaging a lockout assembly, providing for reload recognition, or both, as described in U.S. Provisional Application No. 62/783,429, the entire disclosure of which is incorporated herein by reference.

[00129] FIG. 33 illustrates, as an example, a top view of an operating room employing a robotic surgical system. The robotic surgical system in this case is a robotic surgical system 300 including a Console (“C”) utilized by a Surgeon (“S”) while performing a minimally invasive diagnostic or surgical procedure, usually with assistance from one or more Assistants (“A”), on a Patient (“P”) who is lying down on an Operating table (“O”).

[00130] The Console includes a monitor 304 for displaying an image of a surgical site to the Surgeon, left and right manipulatable control devices 308 and 309, a foot pedal 305, and a processor 302. The control devices 308 and 309 may include any one or more of a variety of input devices such as joysticks, gloves, trigger-guns, hand-operated

controllers, or the like. The processor 302 may be a dedicated computer that may be integrated into the Console or positioned next to it.

[00131] The Surgeon performs a minimally invasive surgical procedure by manipulating the control devices 308 and 309 (also referred to herein as “master manipulators”) so that the processor 302 causes their respectively associated robotic arm assemblies, 328 and 329, (also referred to herein as “slave manipulators”) to manipulate their respective removably coupled surgical instruments 338 and 339 (also referred to herein as “tools”) accordingly, while the Surgeon views the surgical site in 3-D on the Console monitor 304 as it is captured by a stereoscopic endoscope 340.

10 [00132] Each of the tools 338 and 339, as well as the endoscope 340, may be inserted through a cannula or other tool guide (not shown) into the Patient so as to extend down to the surgical site through a corresponding minimally invasive incision such as incision 366. Each of the robotic arms is conventionally formed of links, such as link 362, which are coupled together and manipulated through motor controlled or active joints, such as joint 363.

[00133] The number of surgical tools used at one time and consequently, the number of robotic arms being used in the system 300 will generally depend on the diagnostic or surgical procedure and the space constraints within the operating room, among other factors. If it is necessary to change one or more of the tools being used during a procedure, 20 the Assistant may remove the tool no longer being used from its robotic arm, and replace it with another tool 331 from a Tray (“T”) in the operating room.

[00134] The monitor 304 may be positioned near the Surgeon's hands so that it will display a projected image that is oriented so that the Surgeon feels that he or she is actually looking directly down onto the operating site. To that end, images of the tools 338 and 339 25 may appear to be located substantially where the Surgeon's hands are located.

[00135] The processor 302 performs various functions in the system 300. One function that it performs is to translate and transfer the mechanical motion of control devices 308 and 309 to their respective robotic arms 328 and 329 through control signals over bus 310 so that the Surgeon can effectively manipulate their respective  
5 tools 338 and 339. Another important function is to implement various control system processes as described herein.

[00136] Although described as a processor, it is to be appreciated that the processor 302 may be implemented in practice by any combination of hardware, software and firmware. Also, its functions as described herein may be performed by one unit, or divided  
10 up among different components, each of which may be implemented in turn by any combination of hardware, software and firmware.

[00137] For additional details on robotic surgical systems, see, e.g., commonly owned U.S. Pat. No. 6,493,608, U.S. Pat. No. 6,671, and International Application WO 2017/132611. Each of these disclosures is herein incorporated in its entirety by this  
15 reference.

[00138] FIG. 34 illustrates, as an example, a side view of a simplified (not necessarily in proportion or complete) illustrative robotic arm assembly 400 (which is representative of robotic arm assemblies 328 and 329) holding a surgical instrument 450 (which is representative of tools 338 and 339) for performing a surgical  
20 procedure. The surgical instrument 450 is removably held in tool holder 440. The arm assembly 400 is mechanically supported by a base 401, which may be part of a patient-side movable cart or affixed to the operating table or ceiling. It includes links 402 and 403 which are coupled together and to the base 401 through setup joints 404 and 405.

25 [00139] The setup joints 404 and 405 in this example are passive joints that allow

manual positioning of the arm 400 when their brakes are released. For example, setup joint 404 allows link 402 to be manually rotated about axis 406, and setup joint 405 allows link 403 to be manually rotated about axis 407.

[00140] Although only two links and two setup joints are shown in this example, more or less of each may be used as appropriate in this and other robotic arm assemblies in conjunction with the present disclosure. For example, although setup joints 404 and 405 are useful for horizontal positioning of the arm 400, additional setup joints may be included and useful for limited vertical and angular positioning of the arm 400. For major vertical positioning of the arm 400, however, the arm 400 may also be slidably moved along the vertical axis of the base 401 and locked in position.

[00141] The robotic arm assembly 400 also includes three active joints driven by motors. A yaw joint 410 allows arm section 430 to rotate around an axis 461, and a pitch joint 420 allows arm section 430 to rotate about an axis perpendicular to that of axis 461 and orthogonal to the plane of the drawing. The arm section 430 is configured so that sections 431 and 432 are always parallel to each other as the pitch joint 420 is rotated by its motor. As a consequence, the instrument 450 may be controllably moved by driving the yaw and pitch motors so as to pivot about the pivot point 462, which is generally located through manual positioning of the setup joints 404 and 405 so as to be at the point of incision into the patient. In addition, an insertion gear 445 may be coupled to a linear drive mechanism (not shown) to extend or retract the instrument 450 along its axis 463.

[00142] Although each of the yaw, pitch and insertion joints or gears, 410, 420 and 445, is controlled by an individual joint or gear controller, the three controllers are controlled by a common master/slave control system so that the robotic arm assembly 400 (also referred to herein as a “slave manipulator”) may be controlled through user (e.g., surgeon) manipulation of its associated master manipulator.

[00143] While several embodiments have been shown in the drawings, it is not intended that the disclosure be limited thereto, as it is intended that the disclosure be as broad in scope as the art will allow and that the specification be read likewise. For example, the invention is not limited to the mechanisms described herein for identifying and/or  
5 deactivating stapler cartridges. Other suitable devices or mechanisms are described in co-pending and co-owned International Patent Application No. PCT/US19/66513, filed December 16, 2019 and entitled “SURGICAL INSTRUMENTS WITH SWITCHES FOR DEACTIVATING AND/OR IDENTIFYING STAPLER CARTRIDGES”, the complete disclosure of which is herein incorporated by reference in its entirety for all purposes.  
10 Therefore, the above description should not be construed as limiting, but merely as exemplifications of presently disclosed embodiments. Thus, the scope of the embodiments should be determined by the appended claims and their legal equivalents, rather than by the examples given.

[00144] Persons skilled in the art will understand that the devices and methods  
15 specifically described herein and illustrated in the accompanying drawings are non-limiting exemplary embodiments. The features illustrated or described in connection with one exemplary embodiment may be combined with the features of other embodiments. Various alternatives and modifications can be devised by those skilled in the art without departing from the disclosure. Accordingly, the present disclosure is intended to embrace all such  
20 alternatives, modifications and variances. As well, one skilled in the art will appreciate further features and advantages of the present disclosure based on the above-described embodiments. Accordingly, the present disclosure is not to be limited by what has been particularly shown and described, except as indicated by the appended claims.

**CLAIMS**

1. A surgical stapling instrument comprising:  
an end effector defining a longitudinal axis including a first jaw and a second jaw,  
the first jaw including an anvil and, the second jaw configured to receive a stapler cartridge  
5 having one or more staples and a switch movably coupled to the stapler cartridge;  
a drive member configured to translate distally through the end effector;  
a locking member movable from a disabled position permitting distal translation of  
the drive member to at least an axial position wherein the drive member engages at least  
one of the staples, to a locking position inhibiting distal translation of the drive member to  
10 said axial position; and  
wherein the locking member is configured to move between the disabled and locked  
positions based on a lateral position of the switch.
2. The stapling instrument of claim 1, wherein the locking member is movable  
15 in a first lateral direction substantially perpendicular to the longitudinal axis from the  
disabled position to the locking position.
3. The stapling instrument of claim 2, further comprising the stapler cartridge,  
wherein the switch is positioned within a slot formed on a tail portion of the staple cartridge  
20 and wherein the switch is movable in a lateral direction relative to the longitudinal axis,  
from a first position wherein the switch maintains the locking member in the disabled  
position to a second position wherein the switch disengages the locking member.
4. The stapling instrument of claim 3, wherein the locking member is biased  
25 towards the locking position.

5. The surgical stapling instrument of claim 3, wherein the locking member includes a switch contacting portion and a proximal engagement portion positioned to obstruct the drive member from moving distally when the locking member is in the second  
5 position.

6. The surgical stapling instrument of claim 1, wherein the drive member includes an inclined surface, and a chamfered surface.  
10

7. The surgical stapling instrument of claim 6, wherein upon distal advancement of the drive member, the chamfered surface of the drive member engages a chamfered surface of the switch while the switch is in the first position.  
15

8. The surgical stapling instrument of claim 7, wherein the slot formed on the tail portion of the cartridge includes one or more detents formed therein, the detents being configured to provide mechanical resistance when the drive member engages the switch.  
20

9. The surgical stapling instrument of claim 8, wherein the locking member pivots between the disabled position and the locking position.  
25

10. The surgical stapling instrument of claim 9, wherein the locking member pivots about a pivot point that is laterally offset from the longitudinal axis of the end effector.

11. The surgical stapling instrument of claim 10, wherein the locking member pivots in a direction substantially perpendicular to the longitudinal axis defined by the end effector.

5 12. The surgical stapling instrument according to claim 1 further comprising an actuation mechanism configured to translate the drive member distally through the end effector, wherein the actuation mechanism includes a coil that applies a distal force to the first portion of the drive member.

10 13. The surgical stapling instrument according to claim 1, further comprising an elongated shaft, the end effector mounted on a distal end portion of the elongated shaft.

14. The surgical stapling instrument according to claim 13, further comprising an articulation mechanism configured to articulate the end effector relative to the elongate  
15 shaft.

15. The surgical stapling instrument according to claim 12, further comprising an actuator operatively connected to the actuation mechanism.

20 16. The surgical stapling instrument according to claim 15, wherein the actuator includes a movable handle of a handle assembly provided at the proximal end portion of the surgical instrument.

25 17. The surgical stapling instrument according to claim 15, wherein the actuator includes a control device of a robotic surgical system.

18. The surgical stapling instrument according to claim 1, wherein drive member includes a knife configured to cut tissue grasped between the first and second jaw.

5 19. A surgical stapling instrument comprising:  
a stapler cartridge comprising a switch movably coupled to the stapler cartridge;  
an end effector defining a longitudinal axis including a first jaw and a second jaw,  
the first jaw including an anvil and, the second jaw configured to receive the stapler  
cartridge;

10 a drive member configured to translate distally through the end effector; and  
wherein the drive member is configured to contact the switch at an axial position of  
the drive member relative to the end effector, and wherein the switch is configured to  
provide a detectable resistance upon engagement of the drive member at said axial position.

15 20. The stapling instrument of claim 19, wherein the switch is positioned  
within a slot formed on a tail portion of the stapler cartridge.

21. The stapling instrument of claim 20, wherein the switch is made of metal.

20 22. The stapling instrument of claim, 19 wherein the drive member includes  
an inclined surface, and a chamfered surface.

25 23. The surgical instrument of claim 22, wherein upon distal advancement of  
the drive member, the chamfered surface of the drive member engages a chamfered surface

of the switch.

24. The surgical instrument of claim 23, wherein the surgical instrument is operatively coupled to a control unit, the control unit configured to process the detectable  
5 resistance to identify the stapler cartridge.

25. The surgical instrument of claim 24, further including a locking member, wherein the switch is movable in a first lateral direction substantially perpendicular to the longitudinal axis, from a first position wherein the switch maintains the locking member in  
10 a disabled position to a second position wherein the switch disengages from the locking member.

26. The surgical instrument of claim 20, wherein the slot formed on the tail  
15 portion of the cartridge includes one or more detents formed therein, the detents configured to provide mechanical resistance when the drive member engages the switch.

27. The surgical instrument of claim 25 further comprising an actuation mechanism configured to translate the drive member distally through the end effector,  
20 wherein the actuation mechanism includes a coil that applies a distal force to the first portion of the drive member.

28. The surgical stapling instrument according to claim 27, further comprising an elongated shaft, the end effector mounted on a distal end portion of the elongated shaft.  
25

29. The surgical stapling instrument according to claim 28, further comprising an articulation mechanism configured to articulate the end effector relative to the elongate shaft.

5 30. The surgical stapling instrument according to claim 29, further comprising an actuator operatively connected to the actuation mechanism.

31. The surgical stapling instrument according to claim 30, wherein the actuator includes a movable handle of a handle assembly provided at the proximal end portion of  
10 the surgical instrument.

32. The surgical stapling instrument according to claim 31, wherein the actuator includes a control device of a robotic surgical system.

15 33. The surgical stapling instrument according to claim 32, wherein drive member includes a knife configured to cut tissue grasped between the first and second jaw.

34. The surgical stapling instrument according to claim 19, wherein the switch comprises an annular pin positioned within a channel formed in the stapler cartridge, the  
20 annular pin movable from an unraised position to a second raised position within the channel formed in the stapler cartridge.

35. The surgical instrument according to claim 34, wherein the channel formed in the staple cartridge includes at least one interference structure formed therein, the  
25 interference structure configured to retain the annular pin within the channel formed in the

staple cartridge.

36. The surgical instrument according to claim 35, wherein the annular pin includes one or more undercuts formed thereon to engage with the interference structure to  
5 retain the annular pin within the channel formed in the staple cartridge.

37. The surgical instrument according to claim 36, wherein the surgical instrument is operatively coupled to a control unit, the control unit configured to process the detectable resistance to identify a type of stapler cartridge present in the surgical  
10 stapling instrument.

38. A surgical kit comprising:  
a surgical instrument comprising an end effector defining a longitudinal axis and including a first jaw and a second jaw, and a drive member configured to translate distally  
15 through the end effector; and

a stapler cartridge coupled to the second jaw, the stapler cartridge including a switch positioned at an axial position on the stapler cartridge, the drive member being configured to engage the switch to create a detectable resistance at the axial position.

39. The kit of claim 38, wherein the stapler cartridge is a first staple cartridge, the kit further including a second stapler cartridge, the second stapler cartridge including a second switch positioned at a second axial position different than the axial position of the switch on the first staple cartridge, the drive member configured to engage the switch to create a detectable resistance at the second axial position.

25

40. The surgical instrument of claim 38, wherein the switch comprises an annular pin positioned within a channel formed in the stapler cartridge, the annular pin movable from an unraised position to a raised position within the channel formed in the stapler cartridge.

5

41. The surgical instrument according to claim 40, wherein the channel formed in the staple cartridge includes at least one interference structure formed therein, the interference structure configured to retain the annular pin within the channel formed in the staple cartridge.

10

42. The surgical instrument according to claim 41, wherein the annular pin includes one or more undercuts formed thereon to engage with the interference structure to retain the annular pin within the channel formed in the staple cartridge.

15

43. The surgical instrument according to claim 42, wherein the drive member engages the annular pin at an axial position, the annular pin configured to provide for a detectable resistance upon engagement of the drive member at said axial position.

20

44. The surgical instrument according to claim 43, wherein the surgical instrument is operatively coupled to a surgical system including a control unit, the control unit configured to process the detectable resistance to identify a type of reload present in the stapler cartridge.

25

45. A surgical stapling instrument comprising:  
a stapler cartridge comprising a switch;

an end effector defining a longitudinal axis including a first jaw and a second jaw, the first jaw including an anvil and, the second jaw configured to receive the stapler cartridge;

a drive member configured to translate distally through the end effector;

5 a locking member movable from disabled position permitting distal translation of the drive member to at least an axial position wherein the drive member engages at least one of the staples, to a locking position inhibiting distal translation of the drive member to said axial position; and

10 wherein the drive member is configured to contact the switch at an axial position of the drive member relative to the end effector, and wherein the switch is configured to provide a detectable resistance upon engagement of the drive member at said axial position.

46. The surgical stapling instrument according to claim 45, wherein the switch is movable from a first position wherein the switch maintains the locking member in the disabled position to a second position wherein the switch disengages from the locking member.

47. The surgical stapling instrument according to claim 46, wherein the switch is positioned within a slot formed on a tail portion of the stapler cartridge.

20

48. The surgical stapling instrument according to claim 47, wherein the drive member includes an inclined surface, and a chamfered surface.

49. The surgical stapling instrument according to claim 48, wherein upon distal advancement of the drive member, the chamfered surface of the drive member engages a

25

chamfered surface of the switch while the switch is in the first position.

50. The surgical stapling instrument according to claim 45, wherein the switch comprises an annular pin positioned within a channel formed in the stapler cartridge, the annular pin movable from an unraised position to a second raised position within the channel formed in the stapler cartridge.

51. The surgical stapling instrument according to claim 50, wherein the channel formed in the staple cartridge includes at least one interference structure formed therein, the interference structure configured to retain the annular pin within the channel formed in the staple cartridge.

52. The surgical stapling instrument according to claim 51, wherein the annular pin includes one or more undercuts formed thereon to engage with the interference structure to retain the annular pin within the channel formed in the staple cartridge.

53. The surgical stapling instrument according to claim 52, wherein engagement of the inclined distal portion of the drive member with the annular pin creates a detectable resistance.

54. The surgical stapling instrument according to claim 53, wherein the surgical instrument is operatively coupled to a control unit, the control unit configured to process the detectable resistance to identify the reload present in the stapler cartridge.

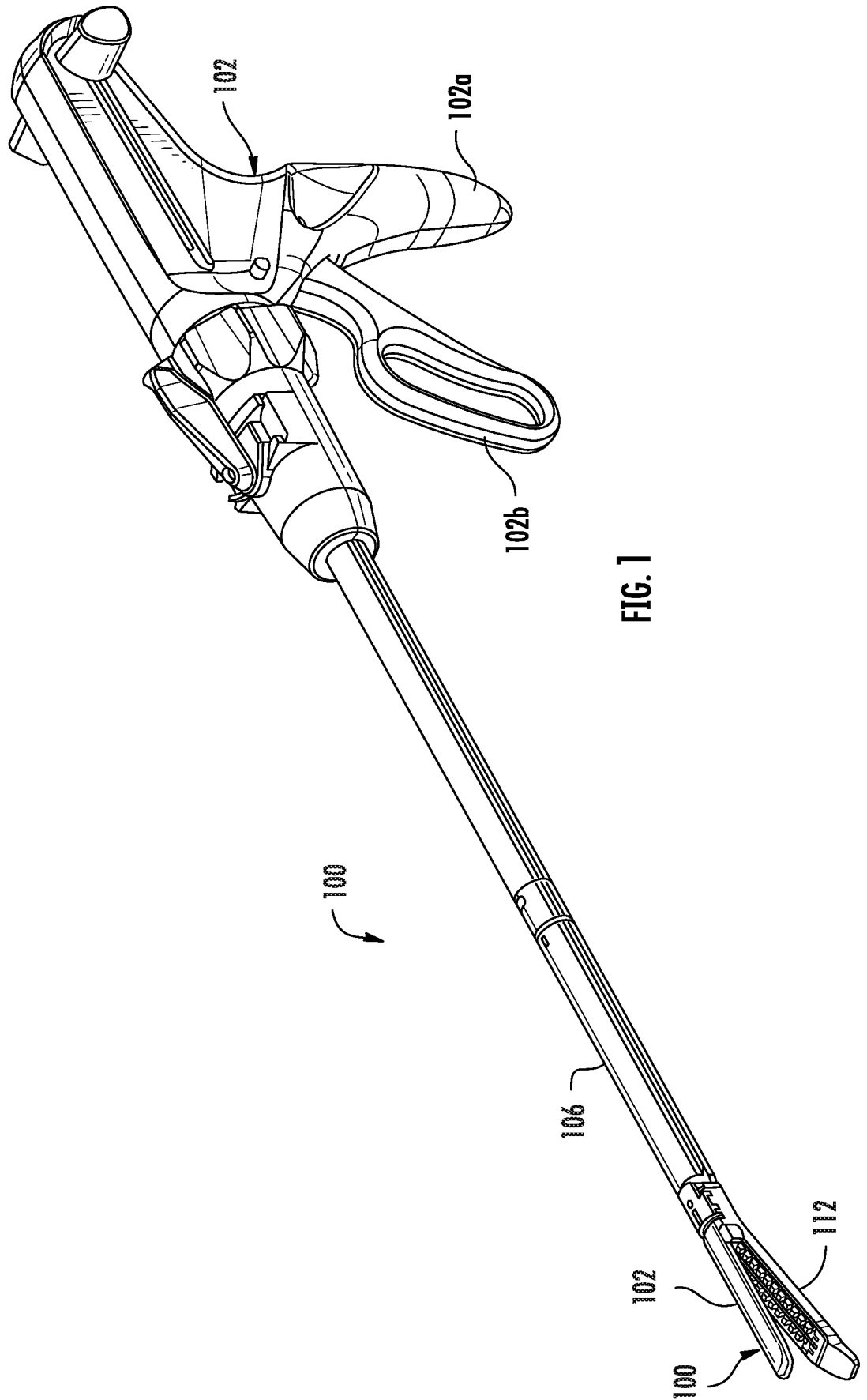

FIG. 1

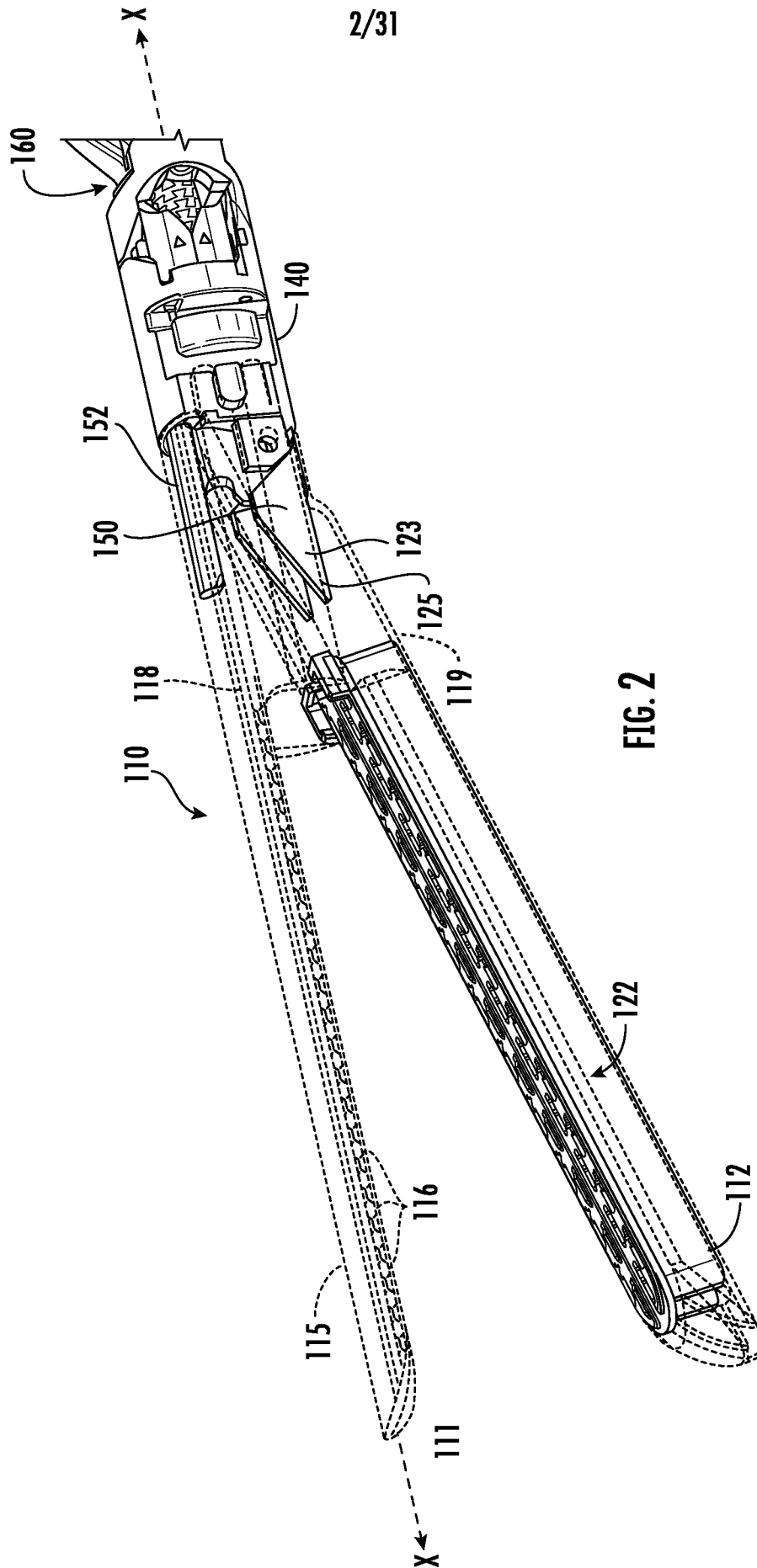

FIG. 2

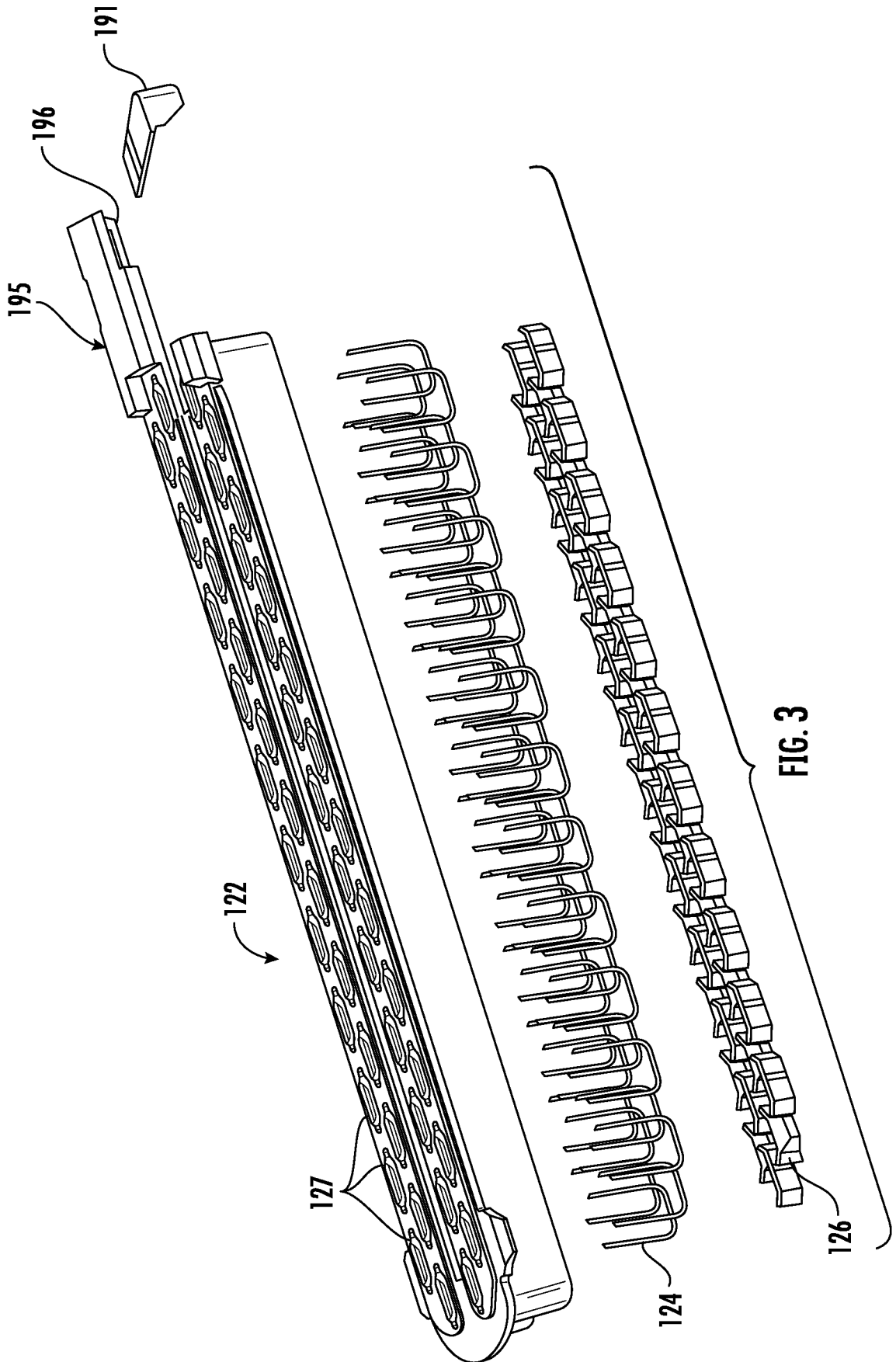

FIG. 3

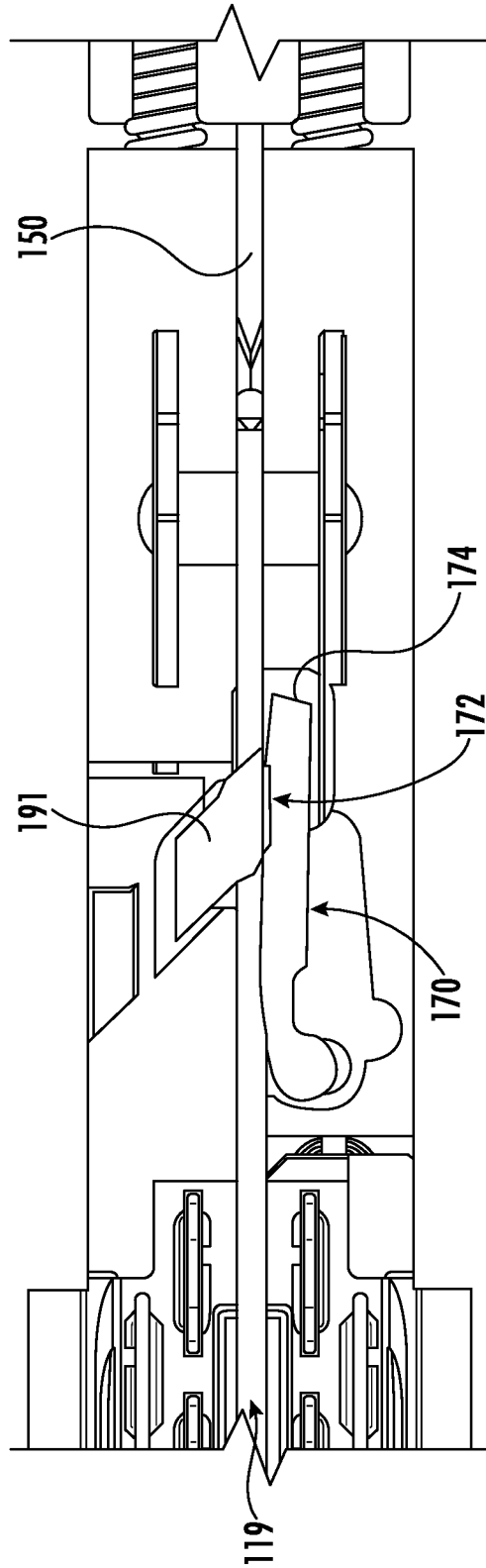

FIG. 4

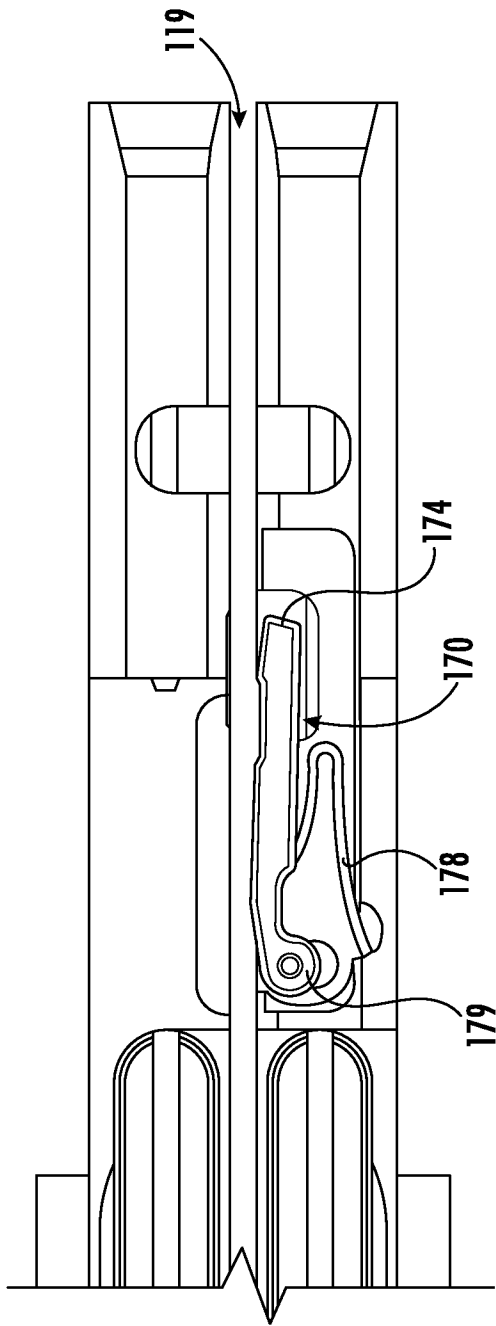

FIG. 5

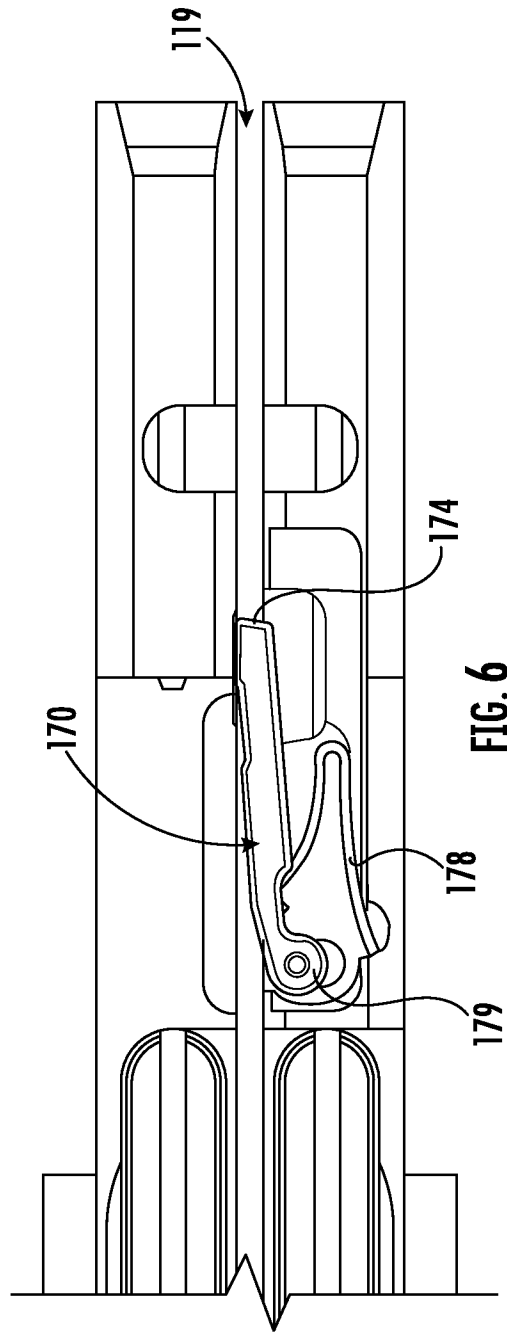
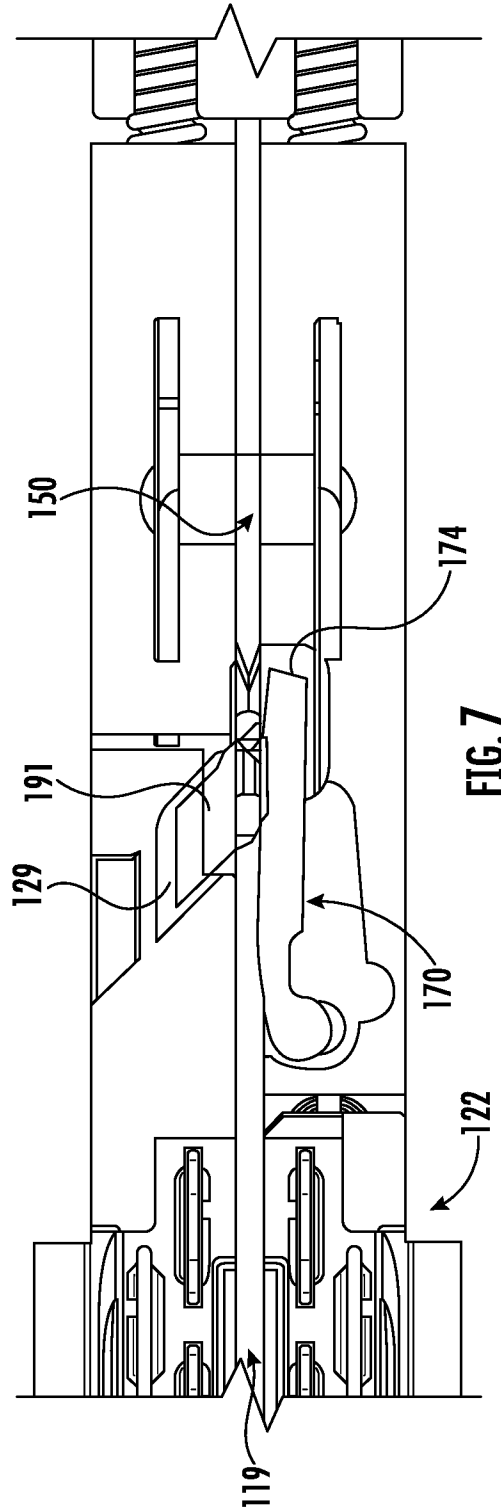

FIG. 6



7/31

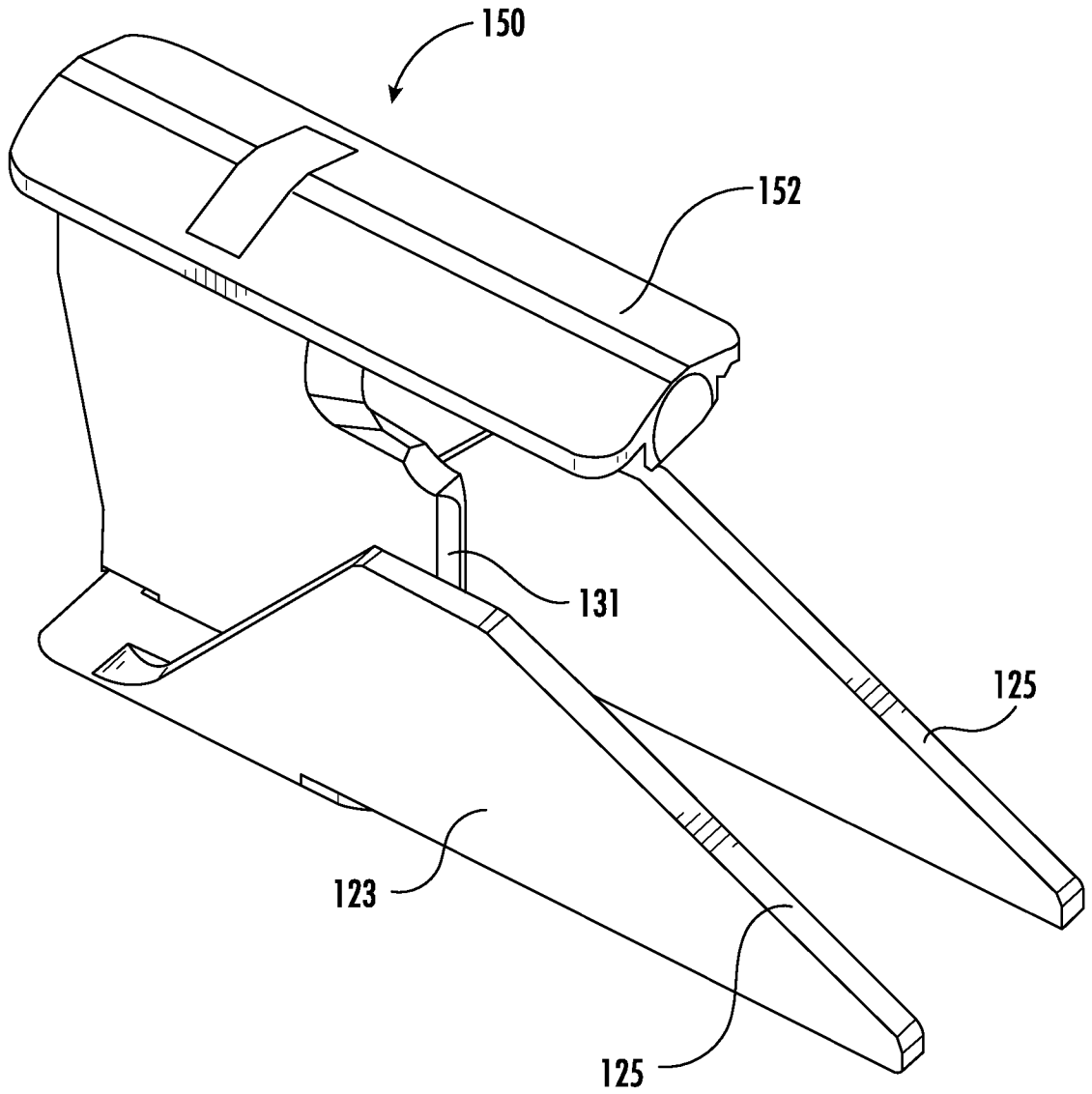
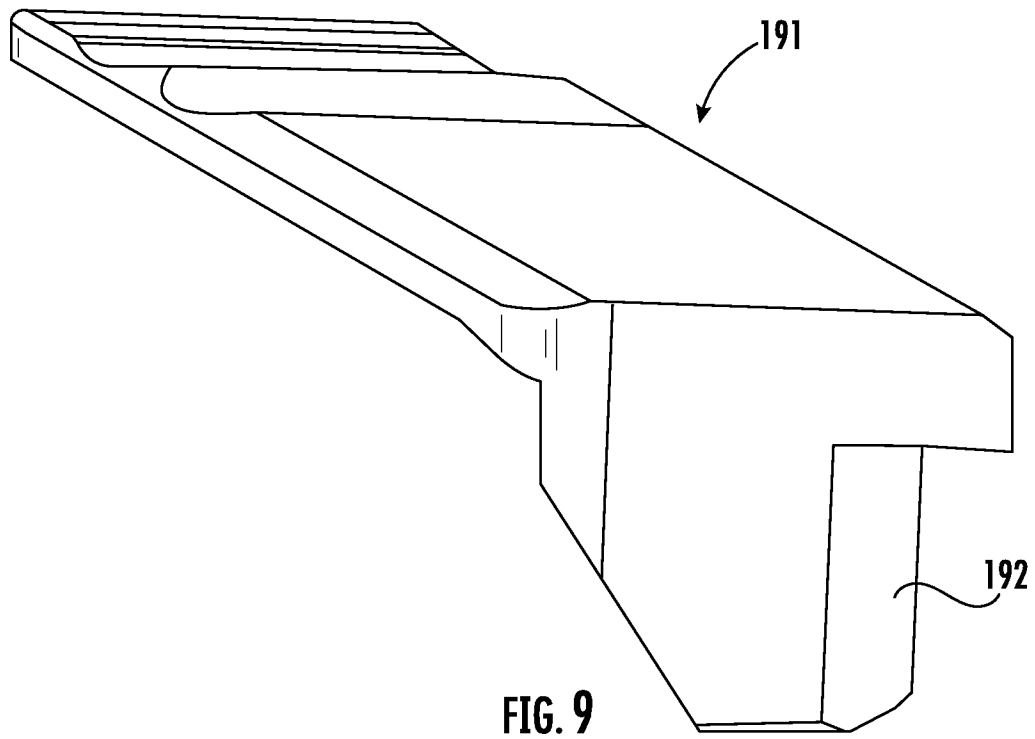

FIG. 8



9/31

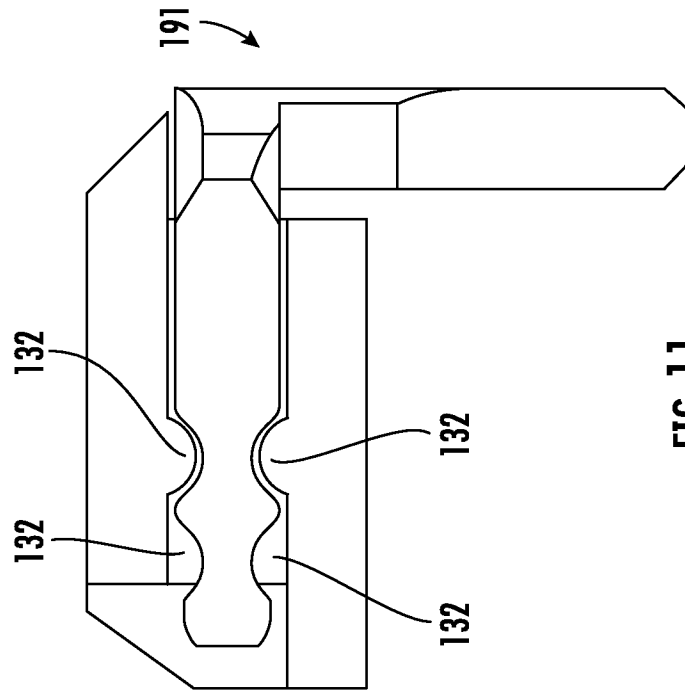

FIG. 11

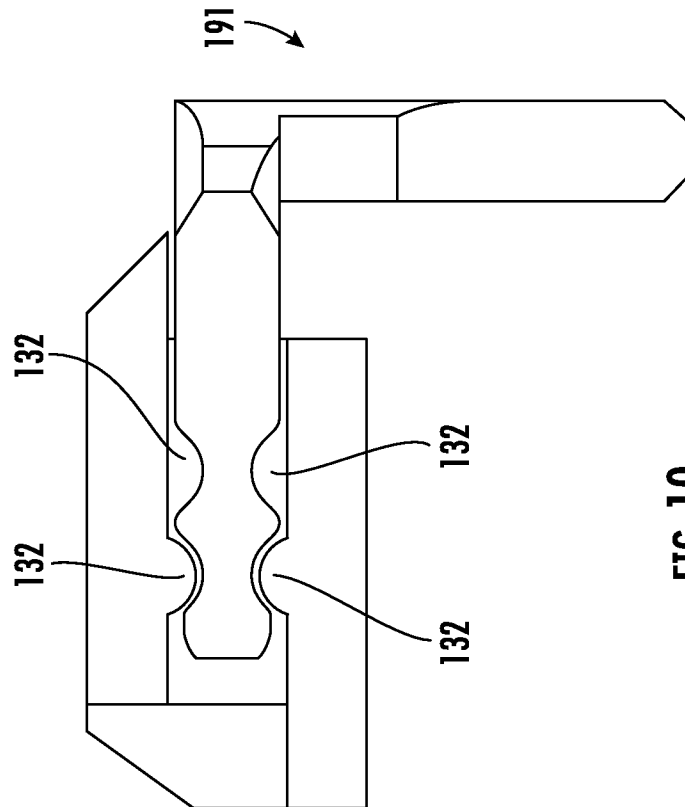

FIG. 10

10/31

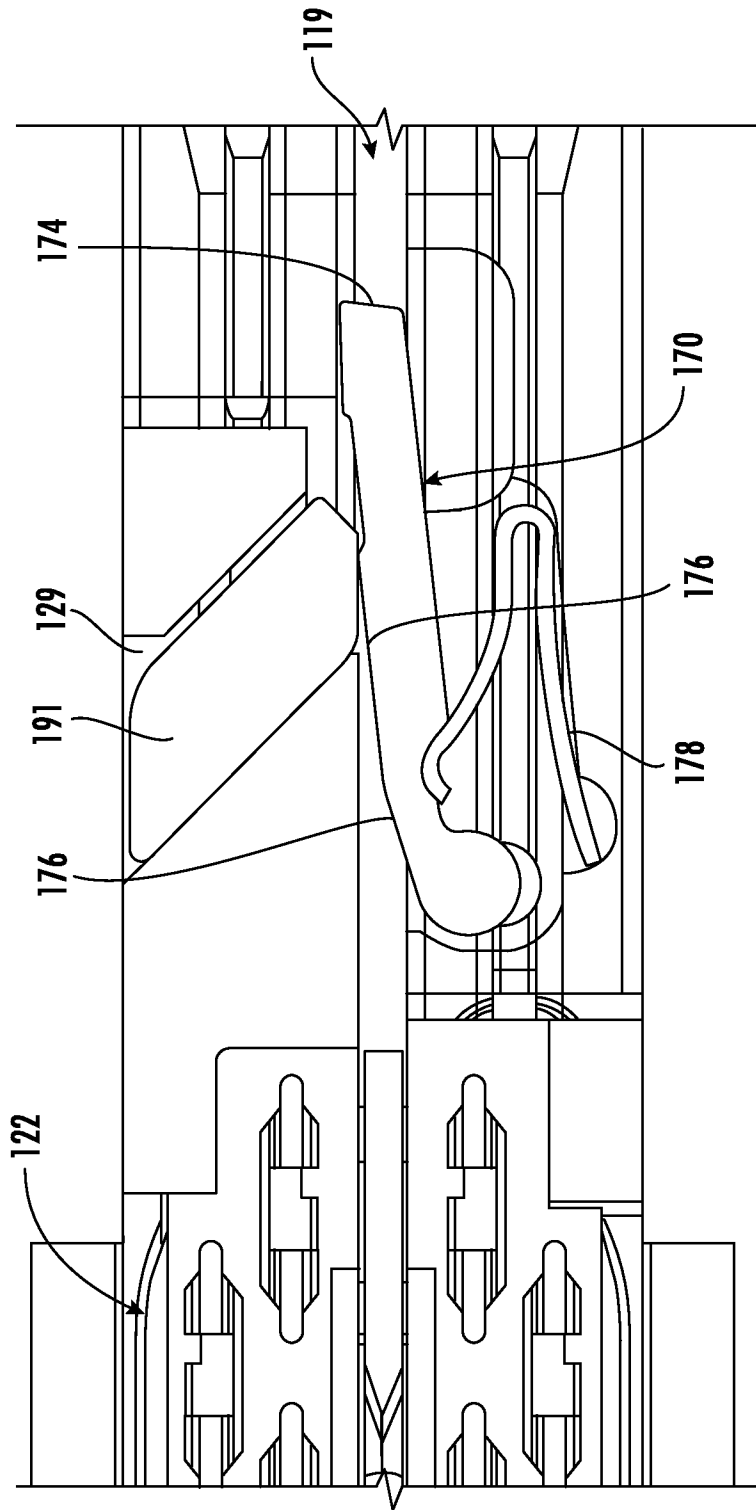

FIG. 12

11/31

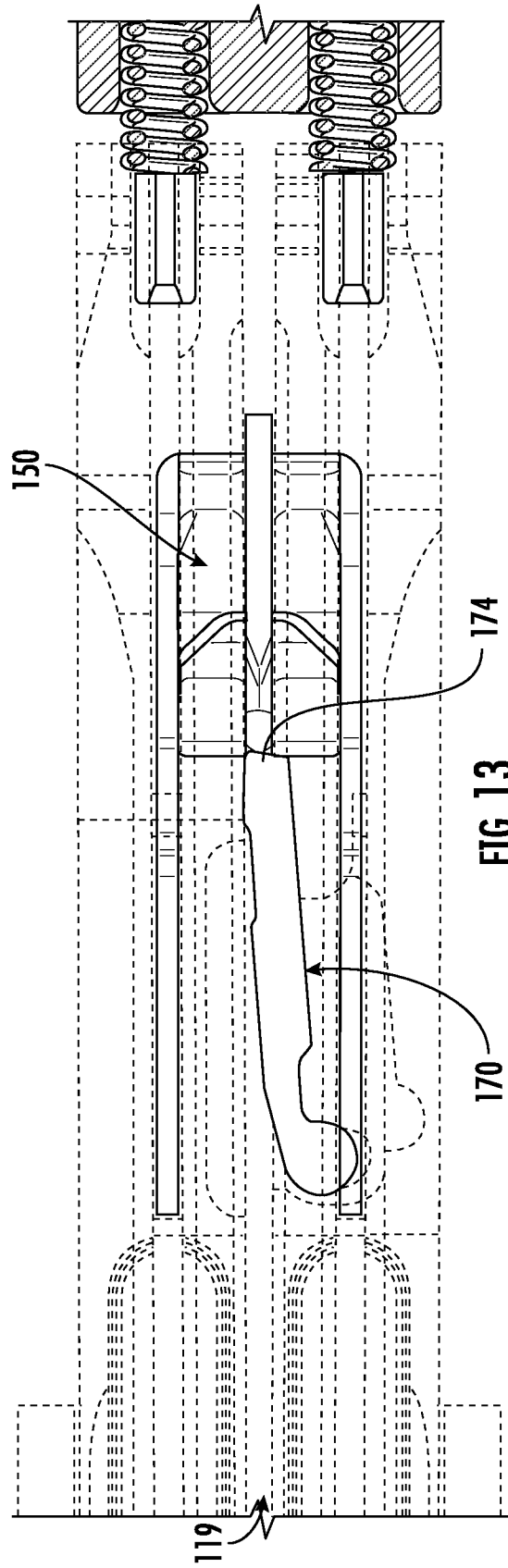
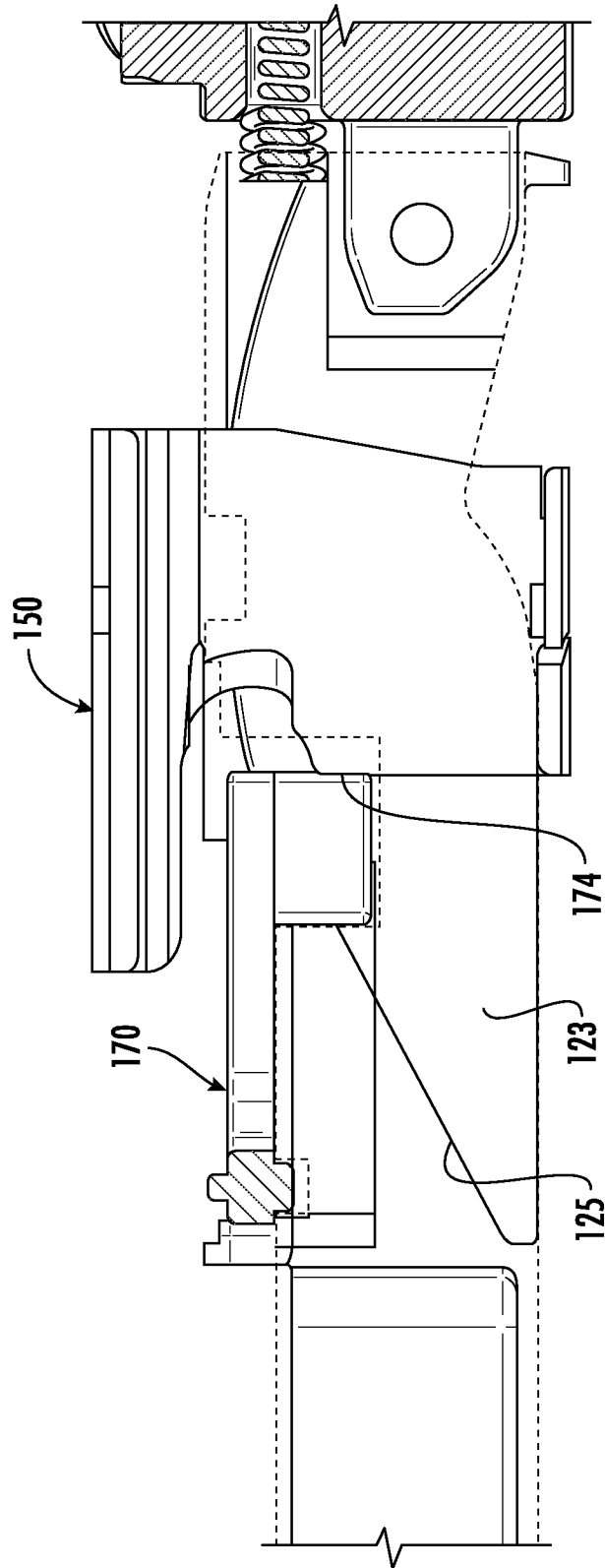

FIG. 13

12/31



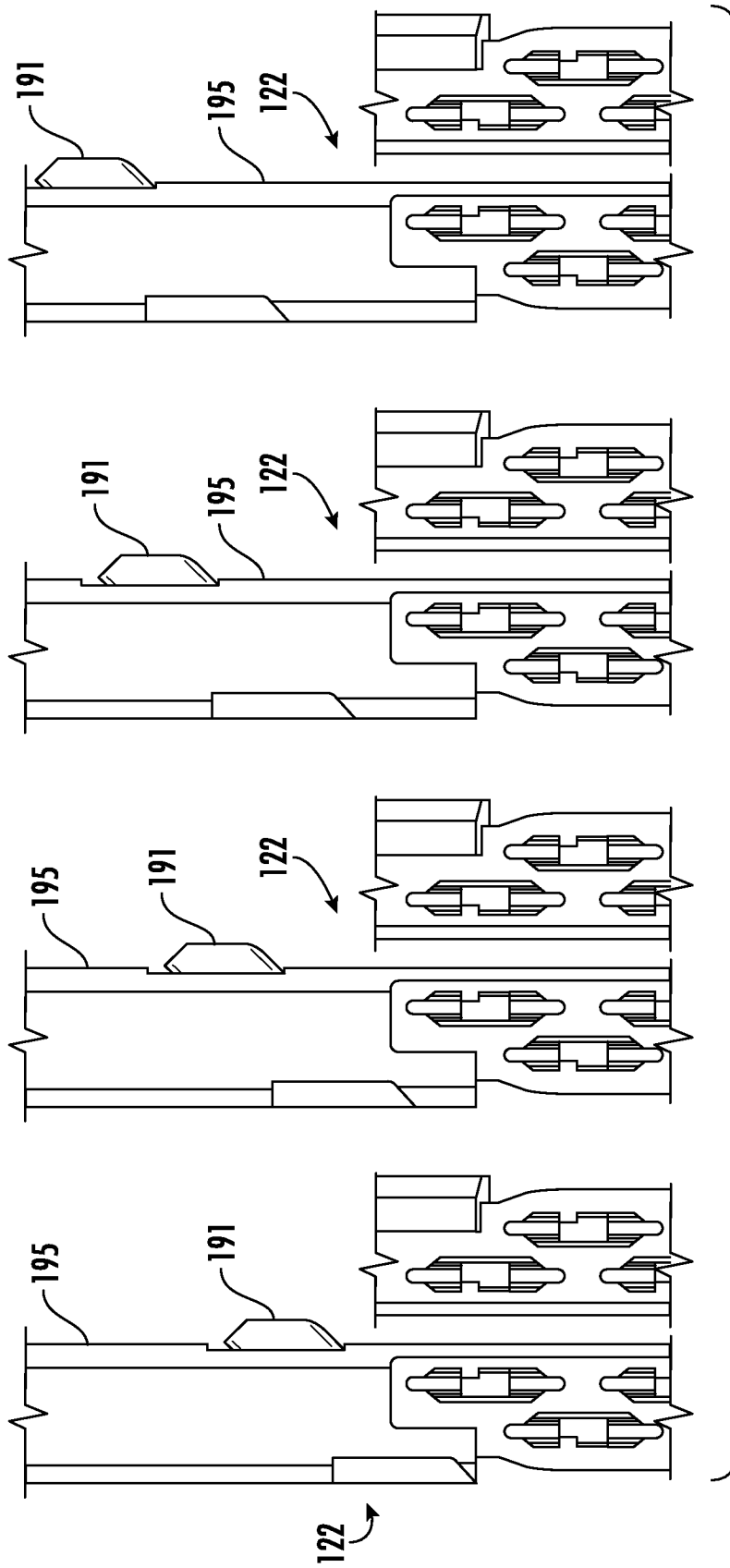

FIG. 15

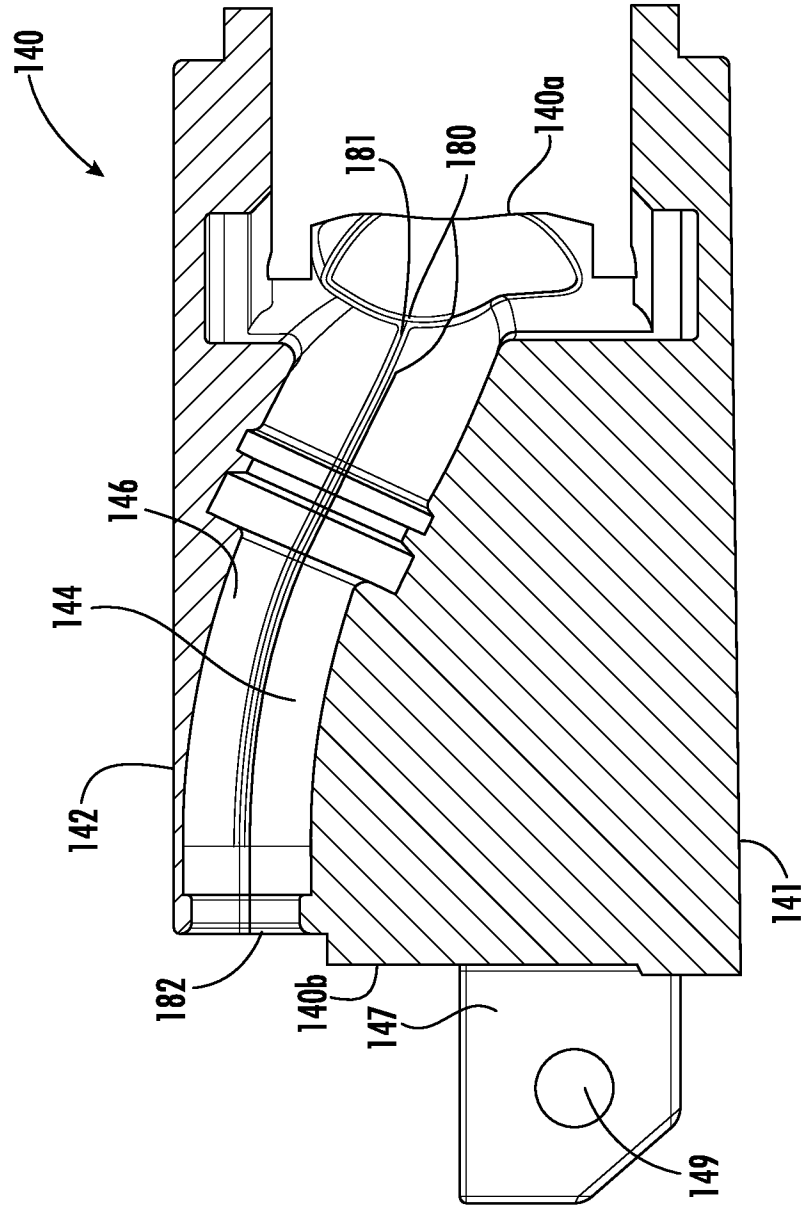
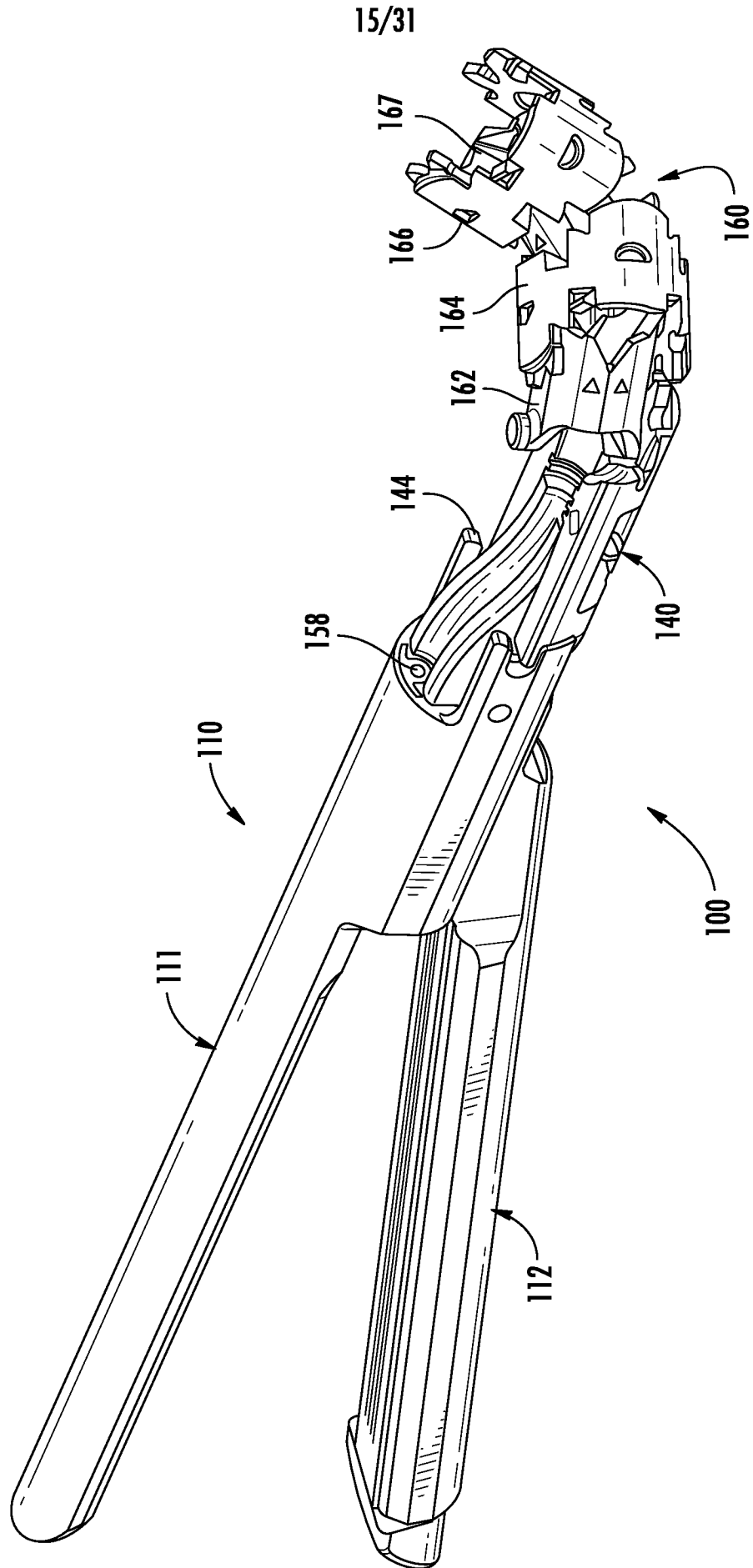

FIG. 16



16/31

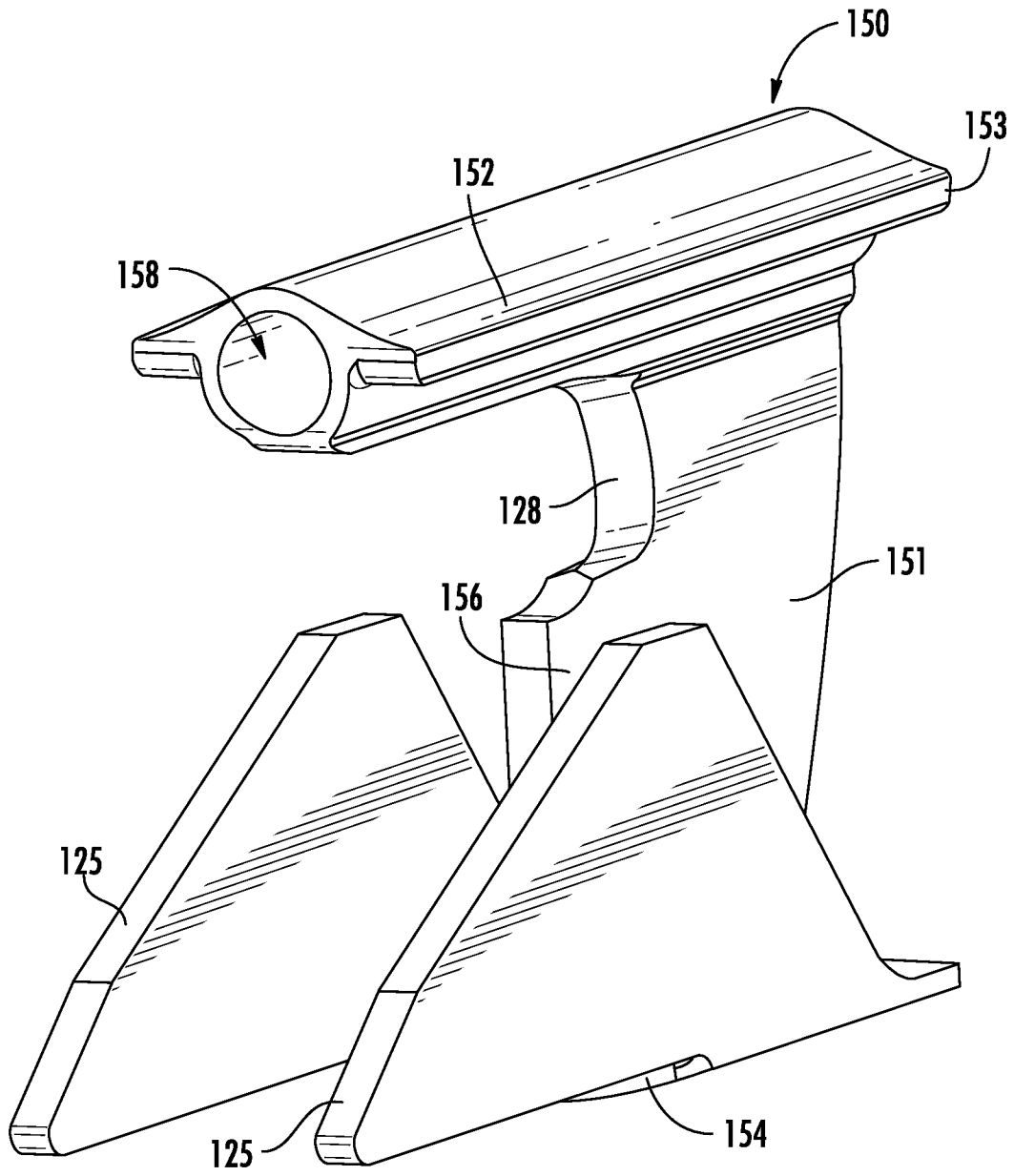

FIG. 18

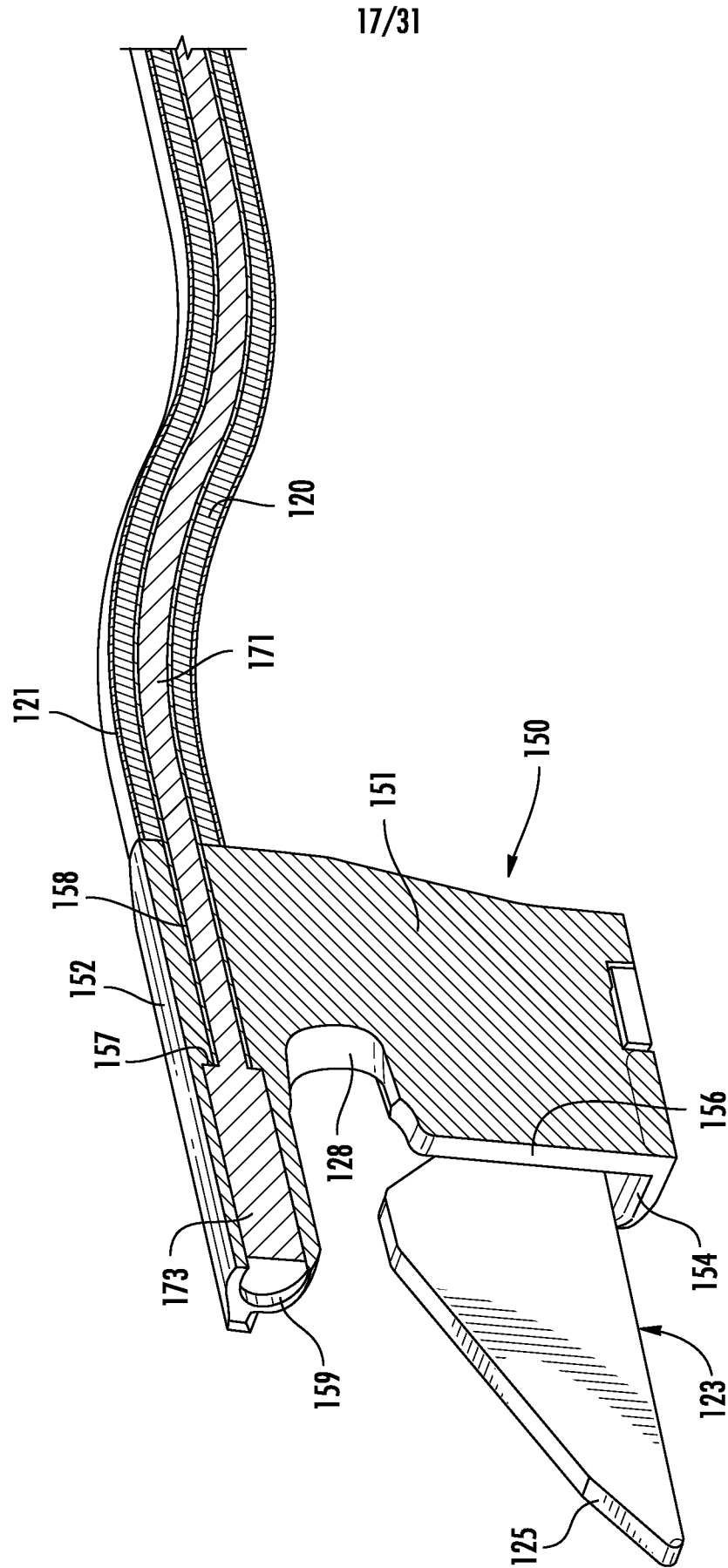

FIG. 19A

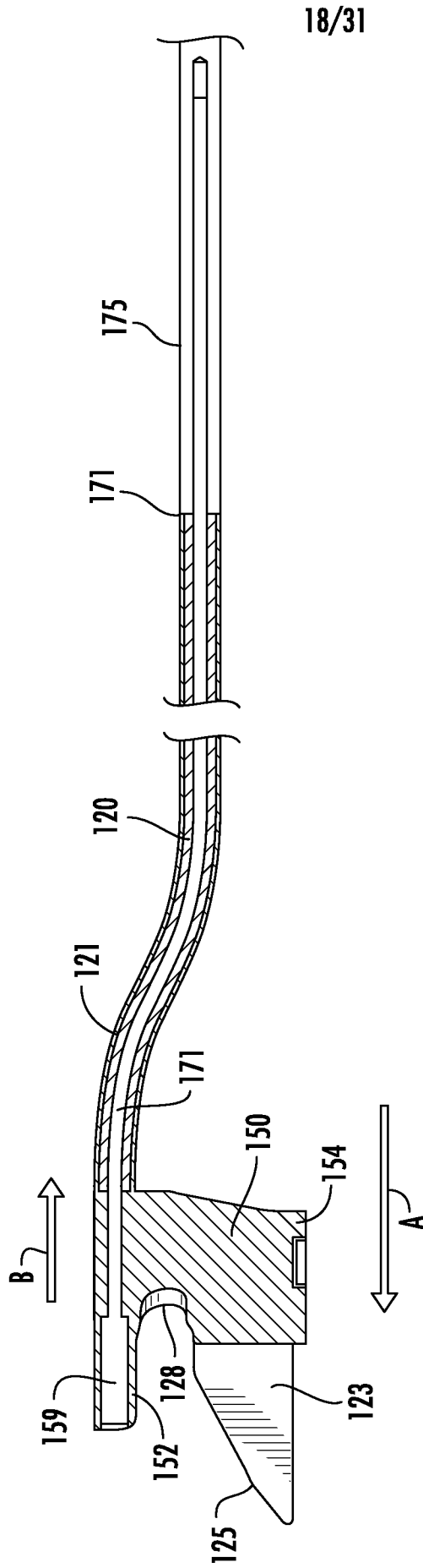
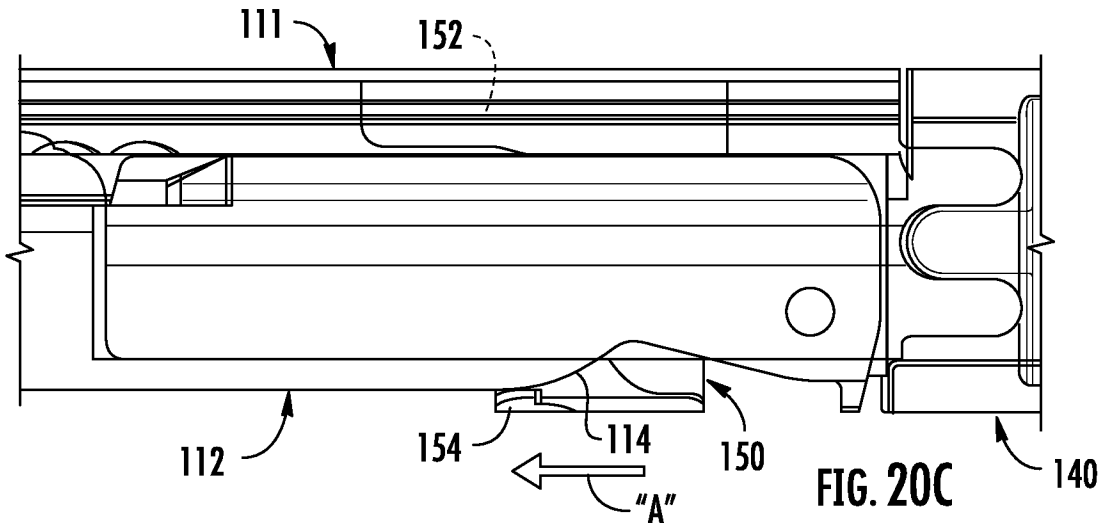
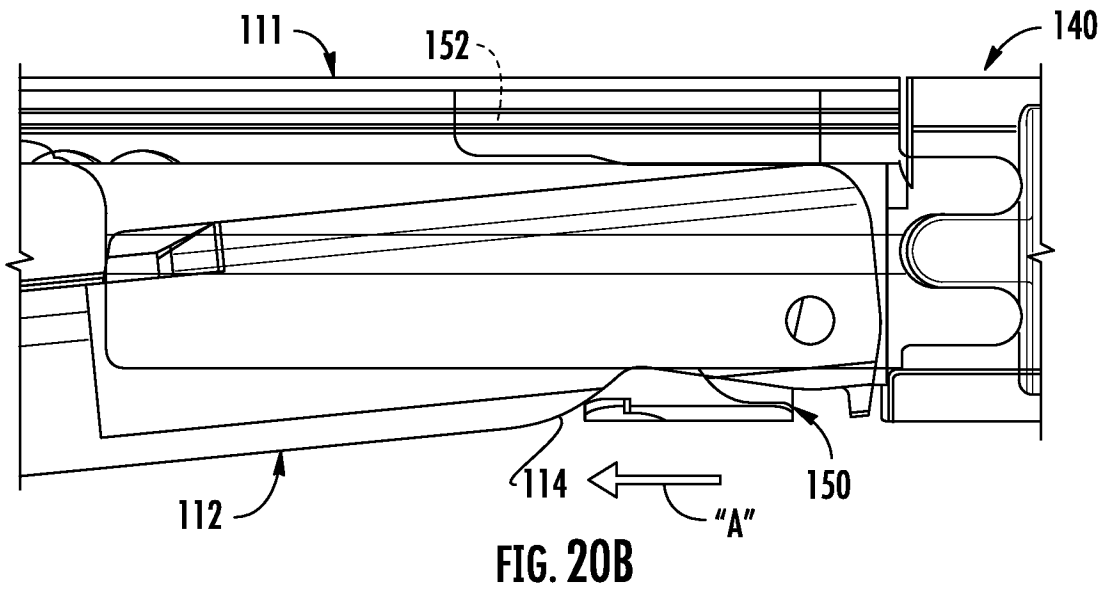
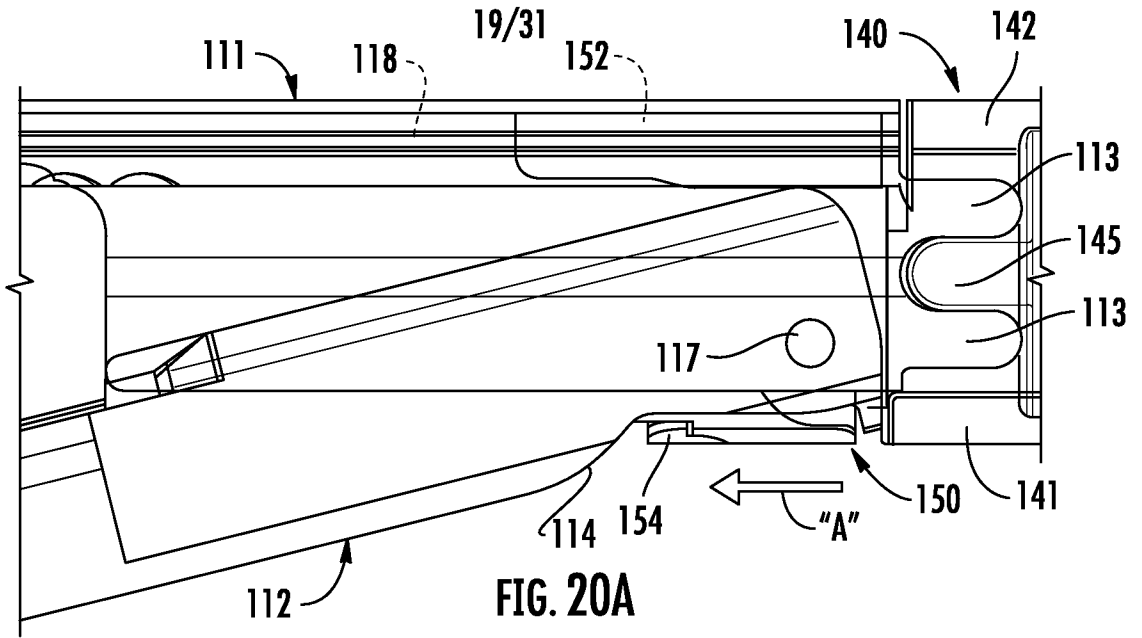

FIG. 19B



20/31

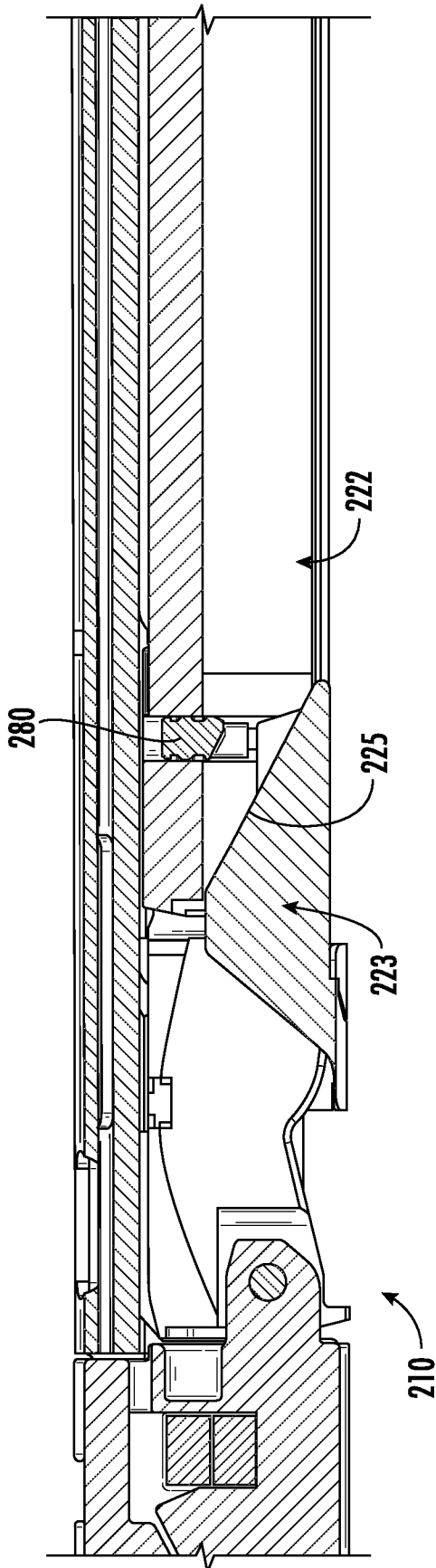
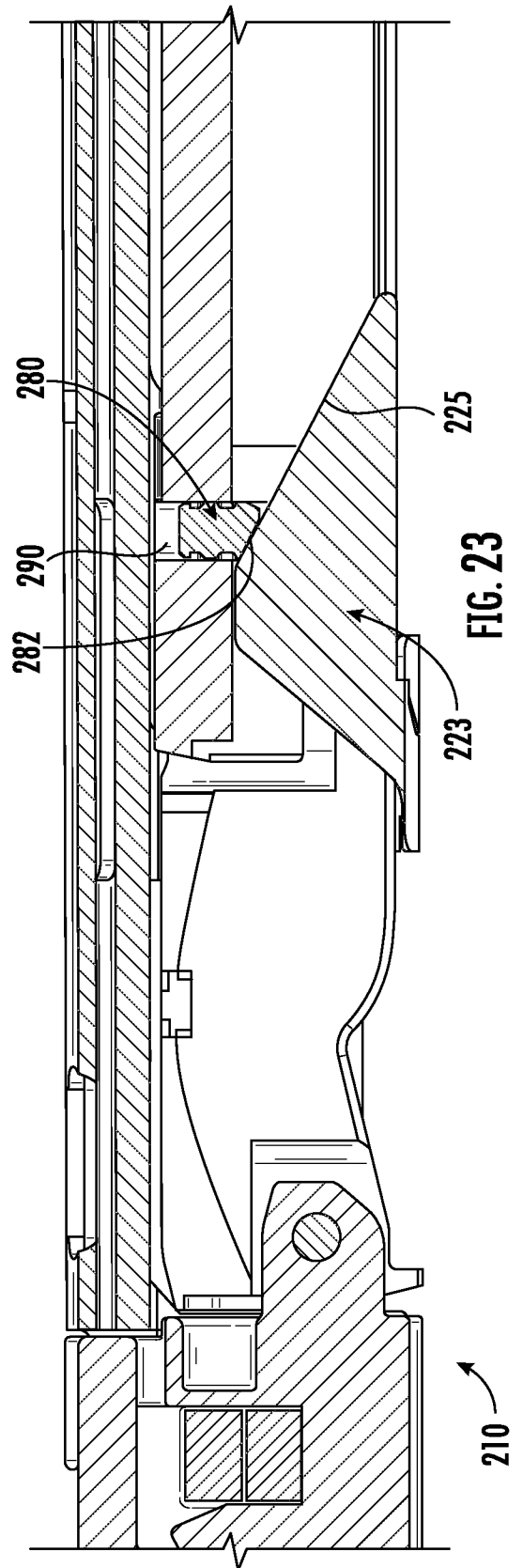
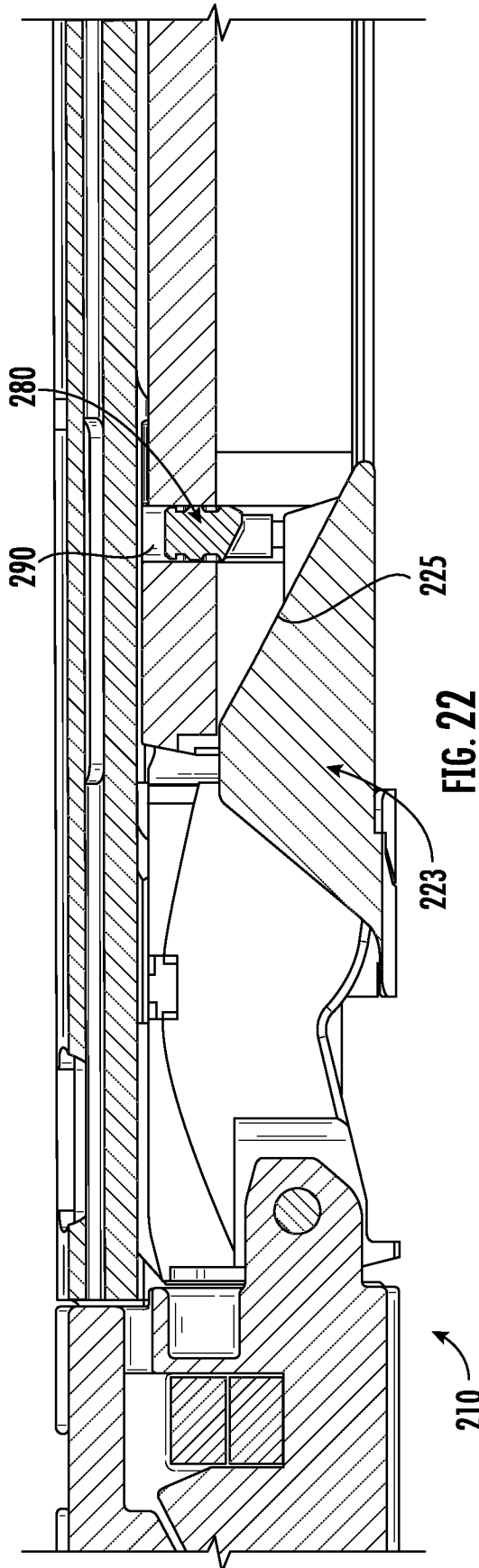

FIG. 21



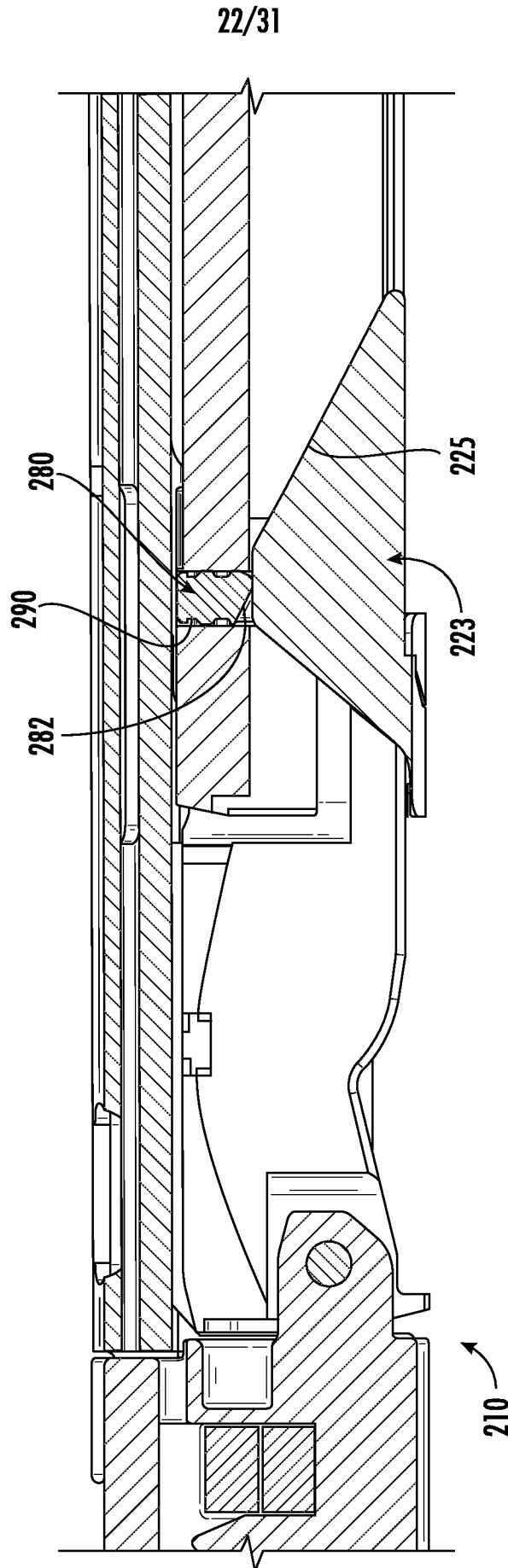

FIG. 24

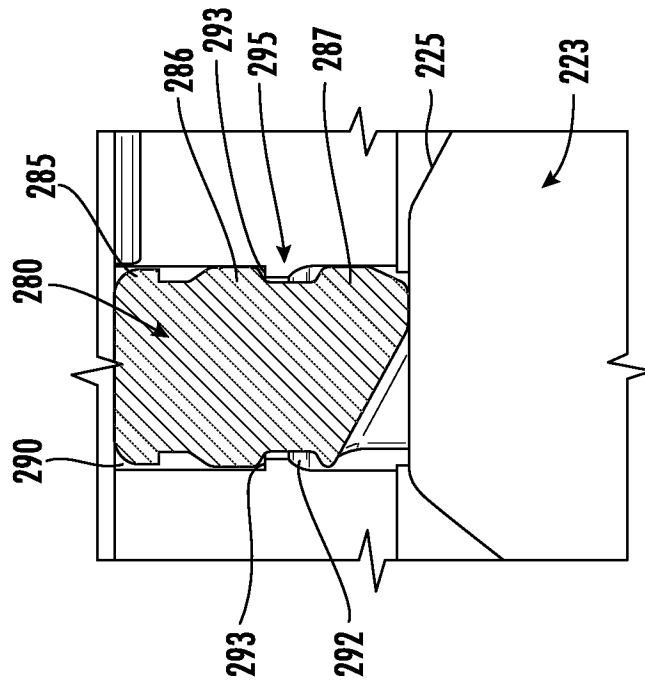

FIG. 25

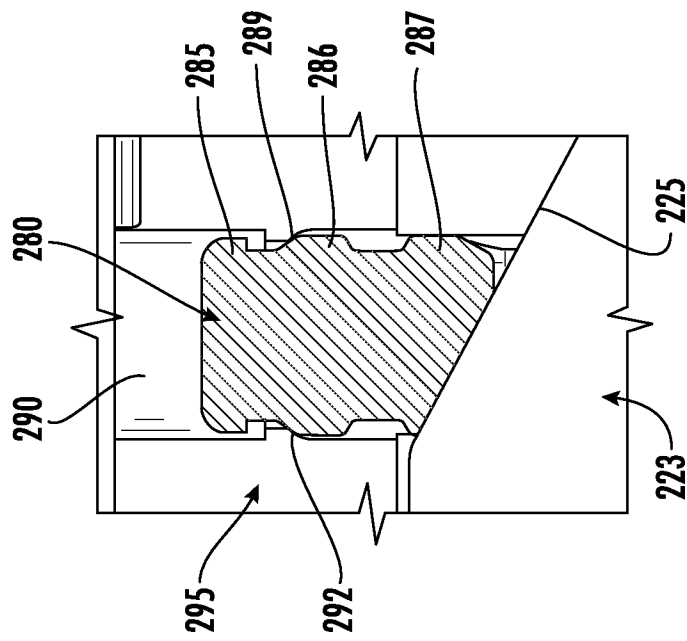

FIG. 26

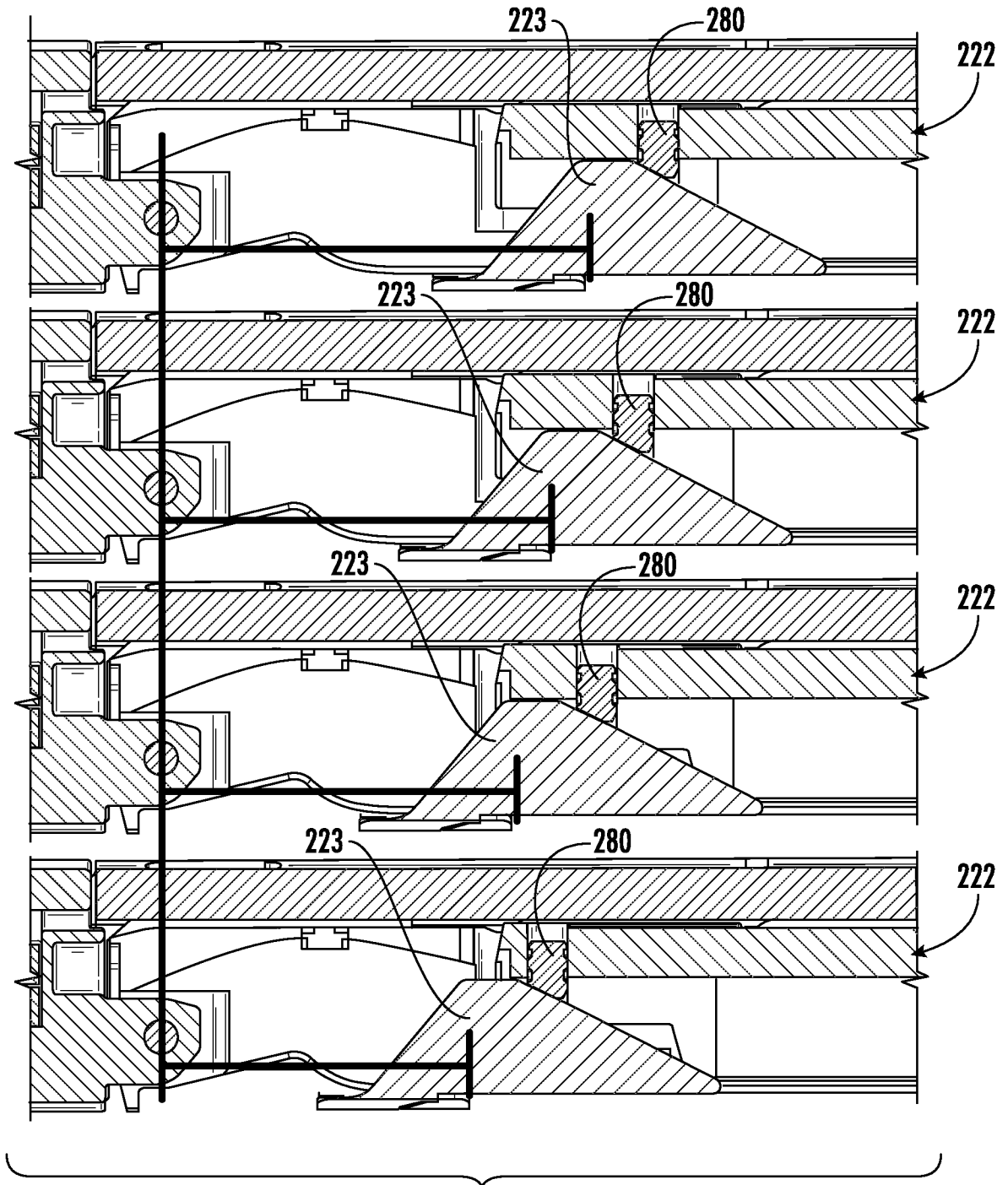

FIG. 26A

25/31

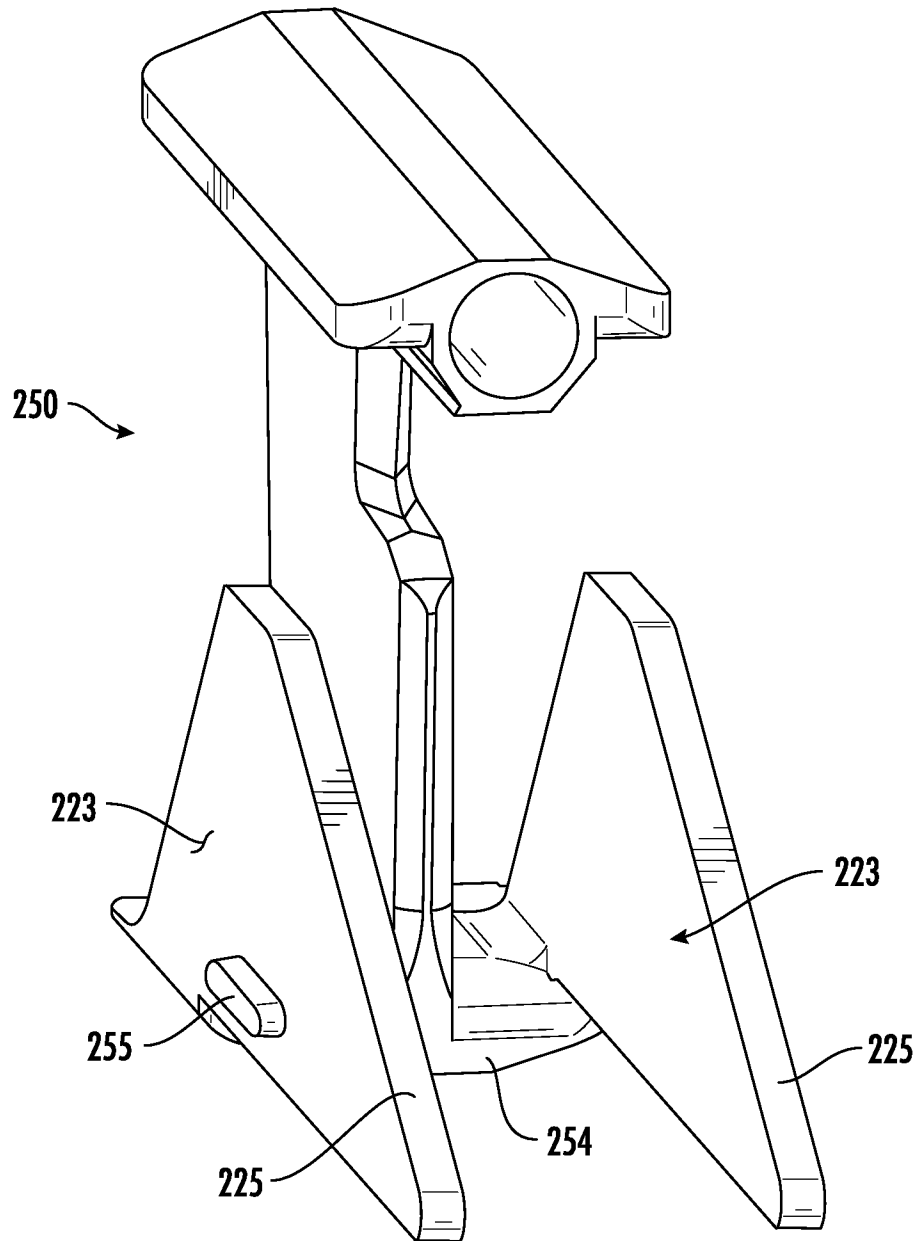

FIG. 27

26/31

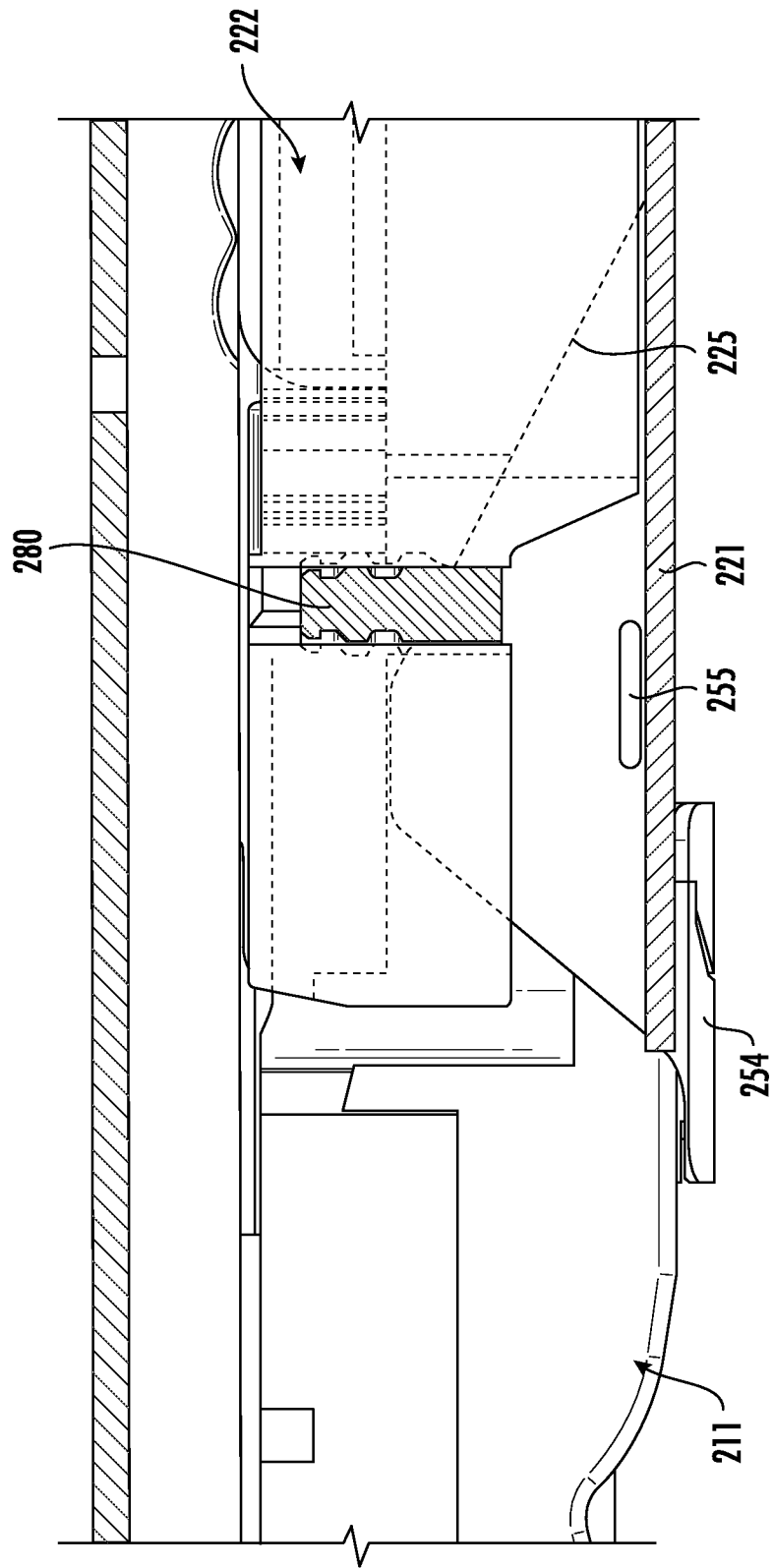

FIG. 28

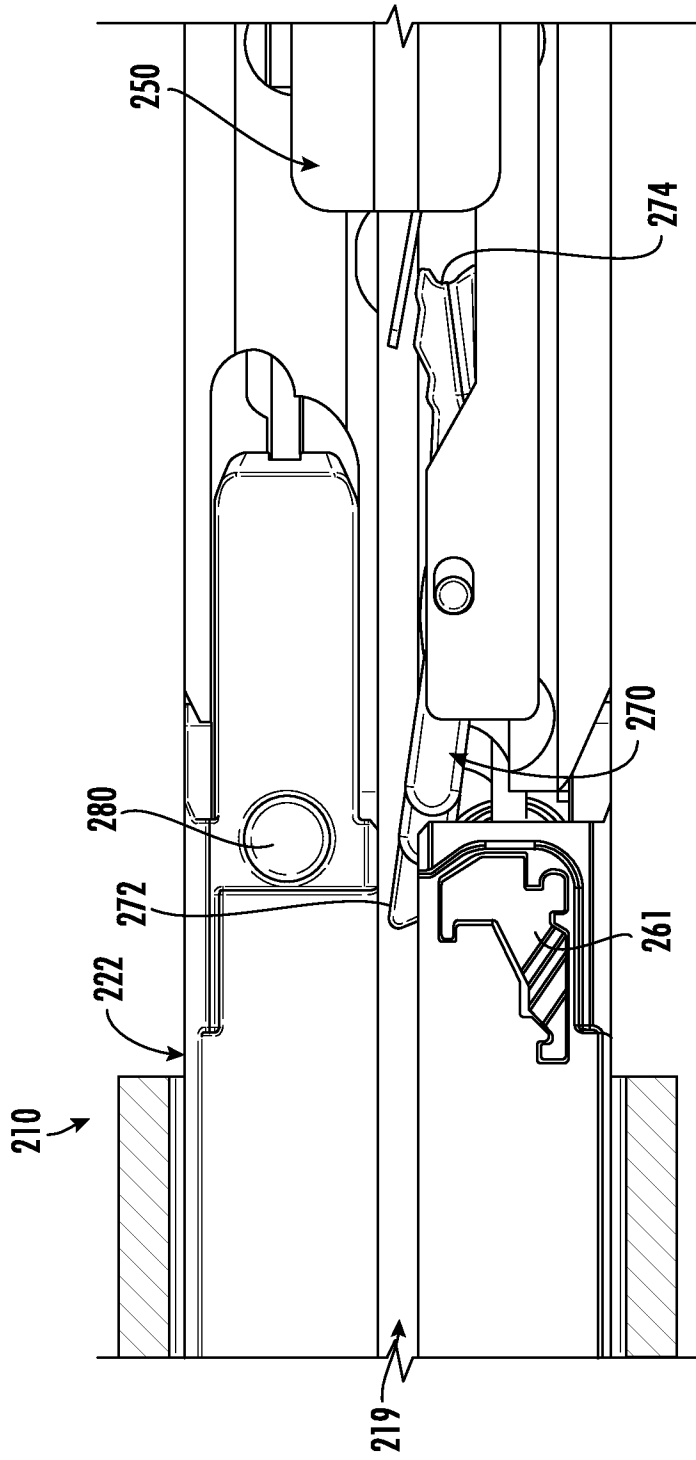

FIG. 29

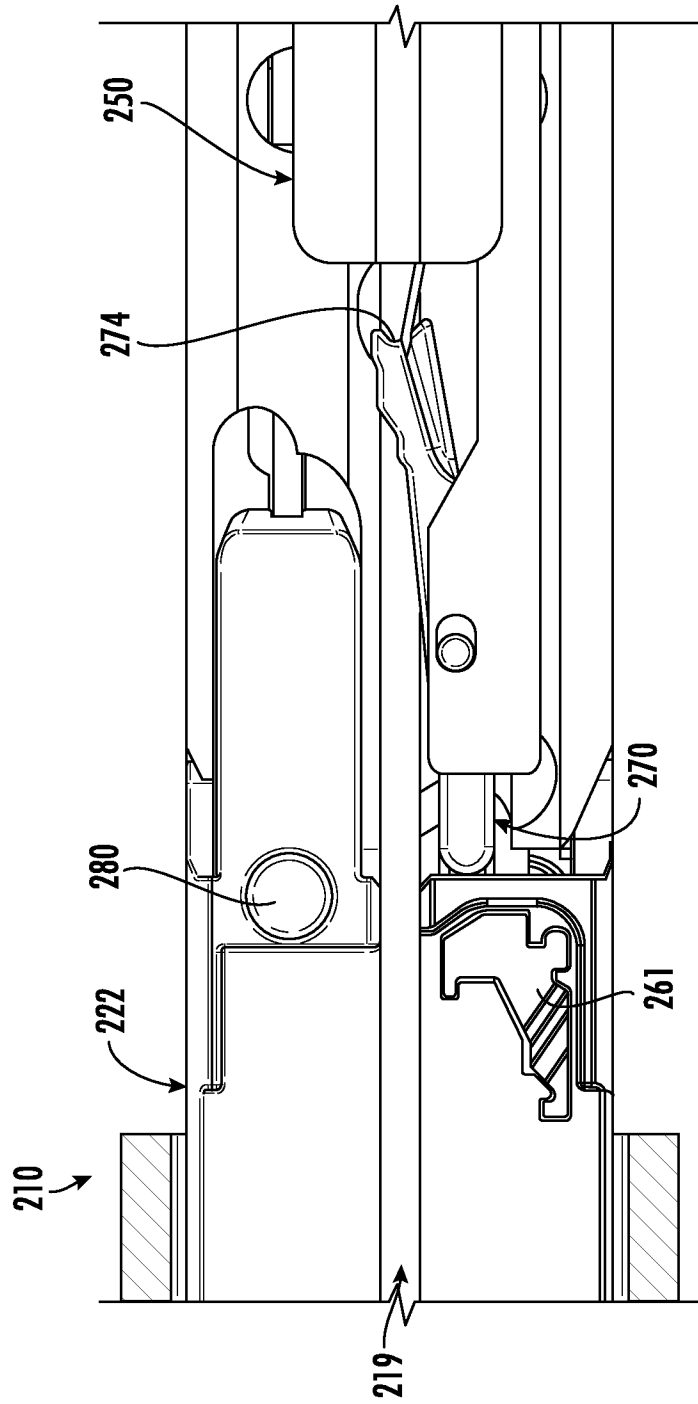

FIG. 30

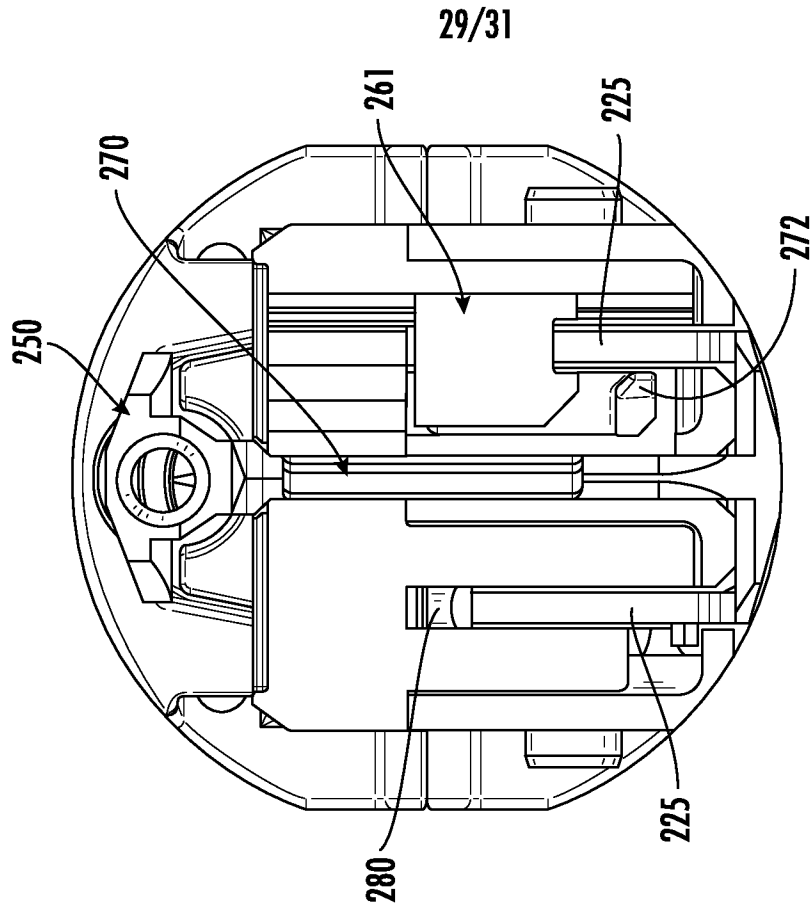

FIG. 32

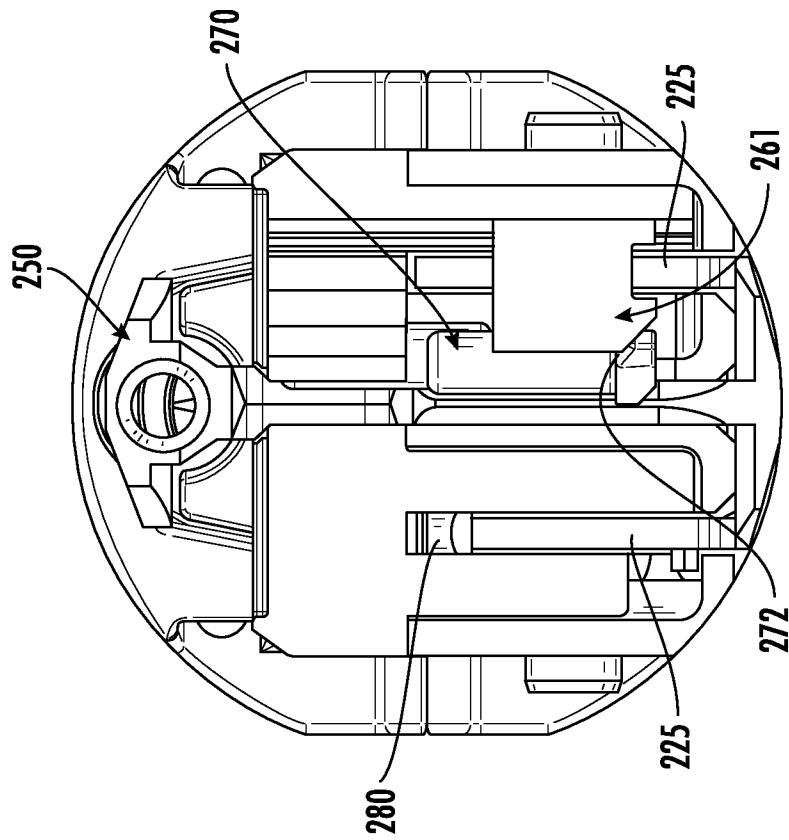
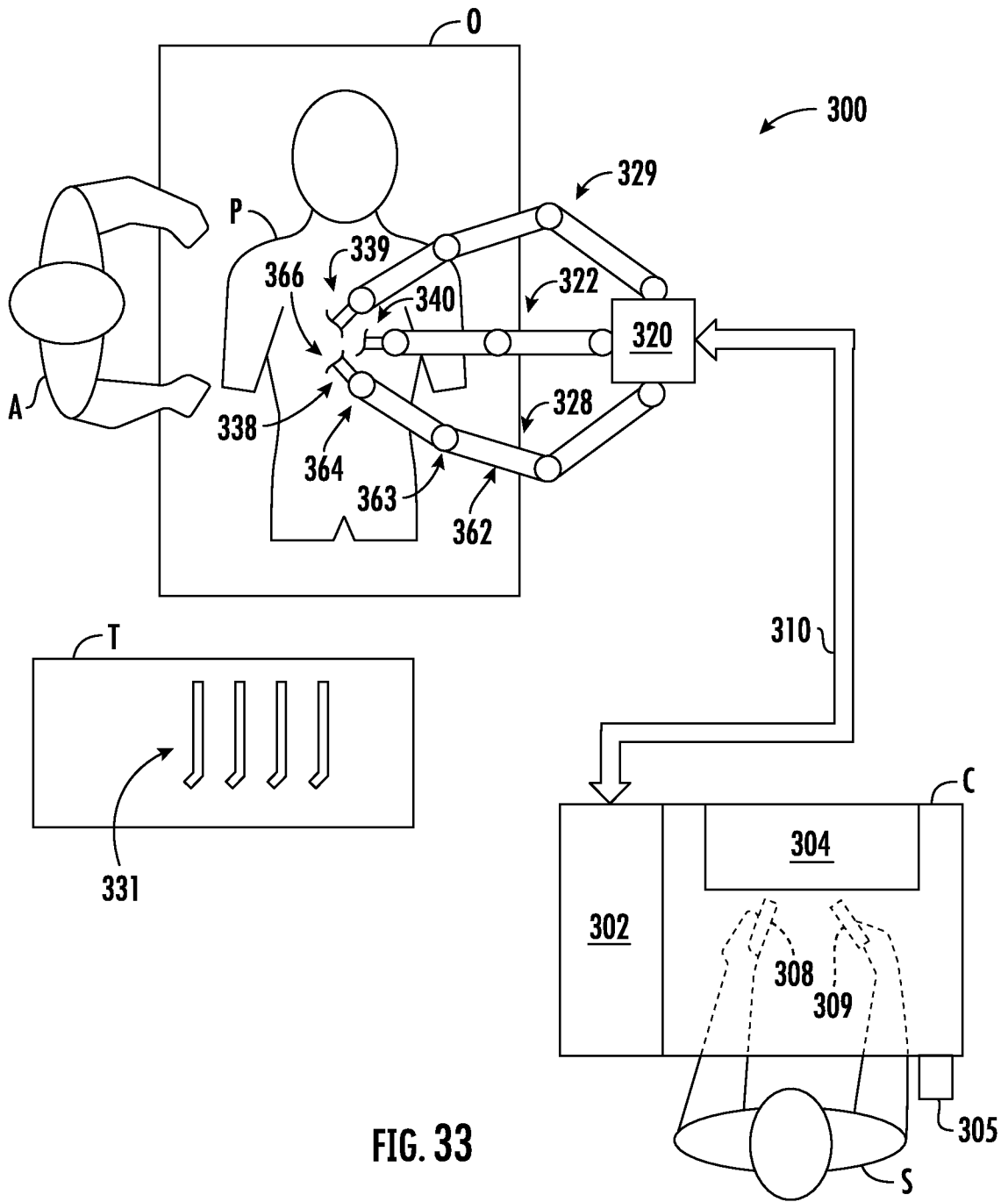
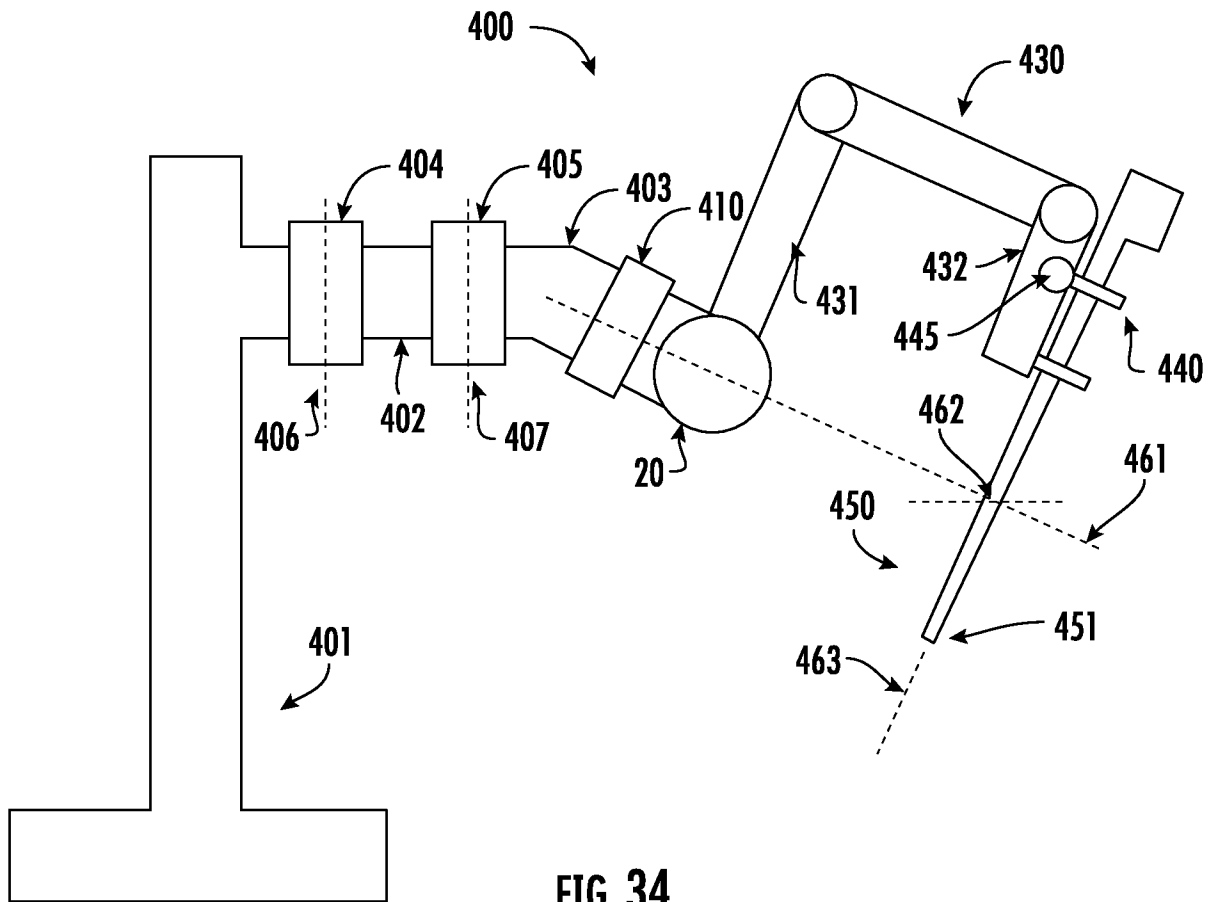

FIG. 31





**A. CLASSIFICATION OF SUBJECT MATTER**

**A61B 17/072(2006.01)i, A61B 17/29(2006.01)i, A61B 17/28(2006.01)i, A61B 34/30(2016.01)i, A61B 34/00(2016.01)i, A61B 17/00(2006.01)i**

According to International Patent Classification (IPC) or to both national classification and IPC

**B. FIELDS SEARCHED**

Minimum documentation searched (classification system followed by classification symbols)

A61B 17/072; A61B 17/068; A61B 17/10; A61B 34/30; A61B 17/29; A61B 17/28; A61B 34/00; A61B 17/00

Documentation searched other than minimum documentation to the extent that such documents are included in the fields searched

Korean utility models and applications for utility models  
Japanese utility models and applications for utility models

Electronic data base consulted during the international search (name of data base and, where practicable, search terms used)

eKOMPASS(KIPO internal) & Keywords:staple, cartridge, locking, switch, resistance, drive member

**C. DOCUMENTS CONSIDERED TO BE RELEVANT**

Category*	Citation of document, with indication, where appropriate, of the relevant passages	Relevant to claim No.
X	US 2018-0168641 A1 (ETHICON ENDO-SURGERY, LLC) 21 June 2018 paragraphs [0328]-[0400], claim 1 and figures 1, 33-37	1-54
A	US 2018-0168581 A1 (ETHICON ENDO-SURGERY, LLC) 21 June 2018 paragraphs [0380]-[0432] and figures 40-42	1-54
A	US 2018-0168649 A1 (ETHICON ENDO-SURGERY, LLC) 21 June 2018 paragraphs [0504]-[0514] and figures 47-53	1-54
A	JP 6411461 B2 (ETHICON ENDO-SURGERY, INC.) 24 October 2018 paragraphs [0079]-[0087] and figures 51-56	1-54
A	JP 2017-527396 A (APPLIED MEDICAL RESOURCES CORP.) 21 September 2017 paragraphs [0083]-[0098] and figures 60-79C	1-54

Further documents are listed in the continuation of Box C.

See patent family annex.

\* Special categories of cited documents:

"A" document defining the general state of the art which is not considered to be of particular relevance

"D" document cited by the applicant in the international application

"E" earlier application or patent but published on or after the international filing date

"L" document which may throw doubts on priority claim(s) or which is cited to establish the publication date of another citation or other special reason (as specified)

"O" document referring to an oral disclosure, use, exhibition or other means

"P" document published prior to the international filing date but later than the priority date claimed

"T" later document published after the international filing date or priority date and not in conflict with the application but cited to understand the principle or theory underlying the invention

"X" document of particular relevance; the claimed invention cannot be considered novel or cannot be considered to involve an inventive step when the document is taken alone

"Y" document of particular relevance; the claimed invention cannot be considered to involve an inventive step when the document is combined with one or more other such documents, such combination being obvious to a person skilled in the art

"&" document member of the same patent family

Date of the actual completion of the international search

21 April 2020 (21.04.2020)

Date of mailing of the international search report

**21 April 2020 (21.04.2020)**

Name and mailing address of the ISA/KR

International Application Division  
Korean Intellectual Property Office  
189 Cheongsa-ro, Seo-gu, Daejeon, 35208, Republic of Korea

Facsimile No. +82-42-481-8578

Authorized officer

Kim, Yeonkyung

Telephone No. +82-42-481-3325



**INTERNATIONAL SEARCH REPORT**

Information on patent family members

International application No.

**PCT/US2019/066530**

Patent document cited in search report	Publication date	Patent family member(s)	Publication date
US 2018-0168641 A1	21/06/2018	CN 110167458 A	23/08/2019
		EP 3338677 A1	27/06/2018
		EP 3338699 A2	27/06/2018
		EP 3338699 A3	01/08/2018
		JP 2020-501781 A	23/01/2020
		US 10568626 B2	25/02/2020
		US 2018-0168635 A1	21/06/2018
		WO 2018-116020 A1	28/06/2018
US 2018-0168581 A1	21/06/2018	CN 110099644 A	06/08/2019
		EP 3338684 A2	27/06/2018
		EP 3338684 A3	04/07/2018
		JP 2020-501770 A	23/01/2020
		US 10582928 B2	10/03/2020
		US 2019-0192159 A1	27/06/2019
		WO 2018-118620 A2	28/06/2018
		WO 2018-118620 A3	04/10/2018
US 2018-0168649 A1	21/06/2018	CN 110099618 A	06/08/2019
		EP 3338710 A2	27/06/2018
		EP 3338710 A3	29/08/2018
		JP 2020-501793 A	23/01/2020
		US 2018-0168645 A1	21/06/2018
		US 2018-0168646 A1	21/06/2018
		WO 2018-116017 A1	28/06/2018
JP 6411461 B2	24/10/2018	BR 112015026071 A2	25/07/2017
		EP 3395261 A2	31/10/2018
		EP 3395261 A3	20/02/2019
		JP 2016-518920 A	30/06/2016
		MX 2015014564 A	23/06/2016
		MX 364727 B	06/05/2019
		RU 2015148781 A	19/05/2017
		RU 2015148781 A3	13/07/2018
		US 10405857 B2	10/09/2019
		US 2014-0309666 A1	16/10/2014
JP 2017-527396 A	21/09/2017	AU 2015-318095 A1	16/03/2017
		AU 2015-318095 B2	20/02/2020
		CA 2962184 A1	24/03/2016
		EP 3193742 A1	26/07/2017
		KR 10-2017-0060064 A	31/05/2017
		US 2016-0374678 A1	29/12/2016
		WO 2016-044216 A1	24/03/2016