

(No Model.)

2 Sheets—Sheet 1.

J. O. BUTLER. GANG CIRCULAR SAWING MACHINE.

No. 408,790.

Patented Aug. 13, 1889.

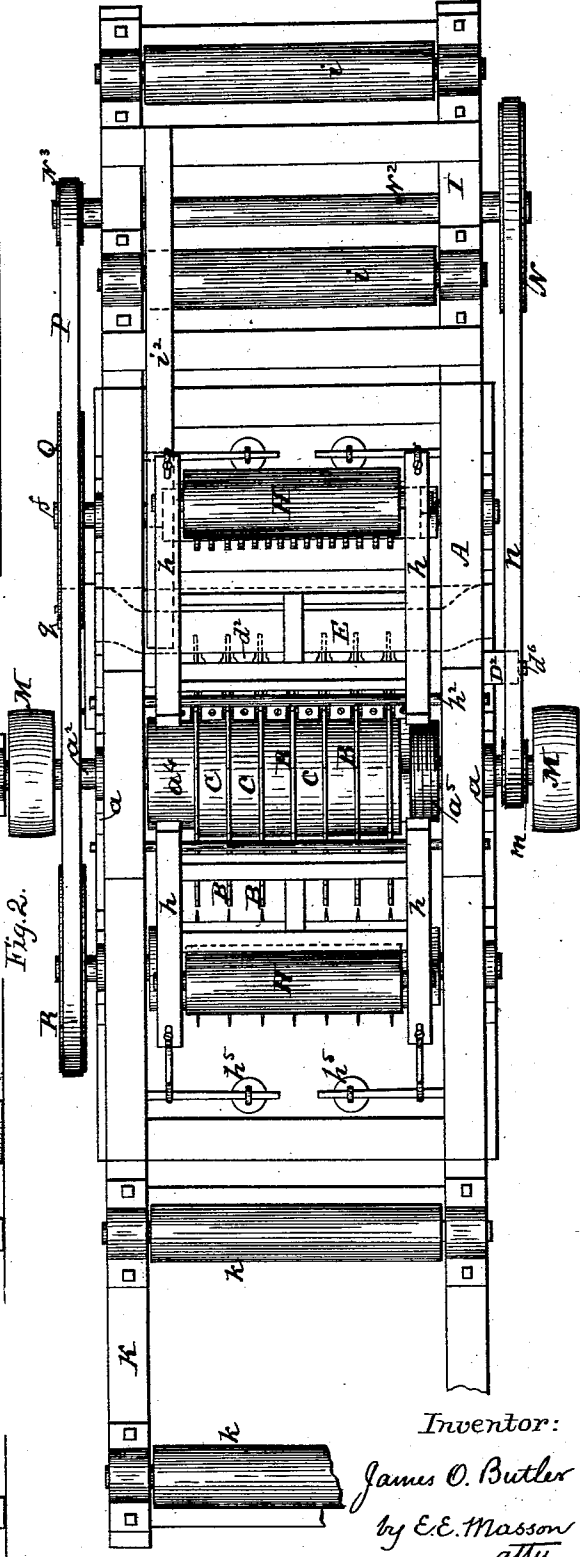
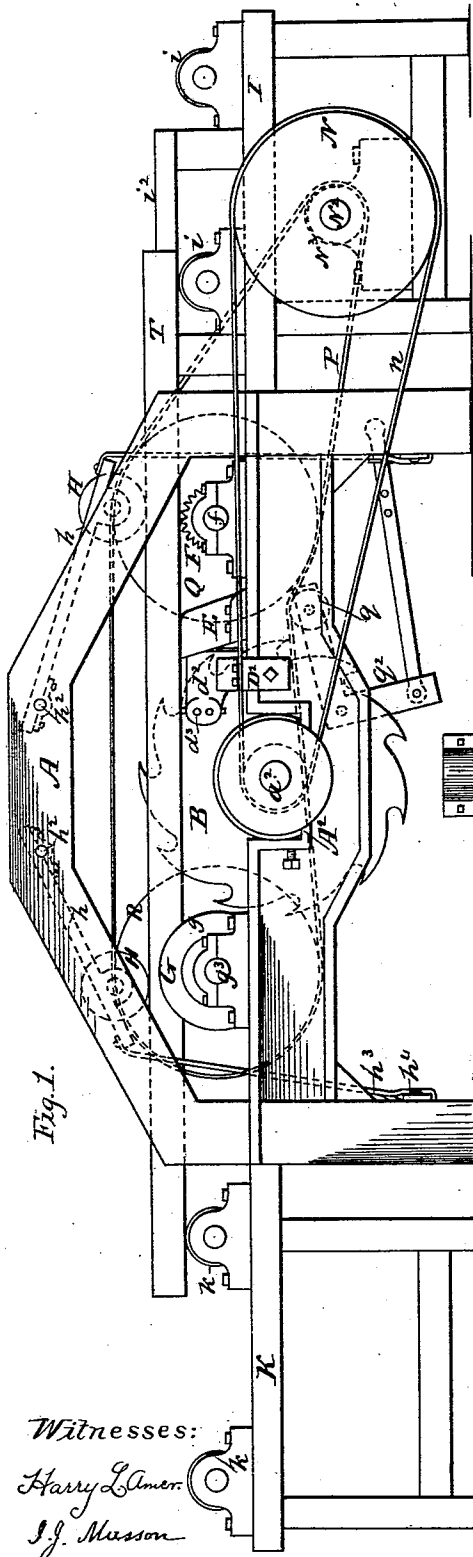

Witnesses:

Harry Lamer.

J. J. Masson

Inventor:

James O. Butler
by E. E. Masson
att'y.

J. O. BUTLER.
GANG CIRCULAR SAWING MACHINE.

No. 408,790.

Patented Aug. 13, 1889.

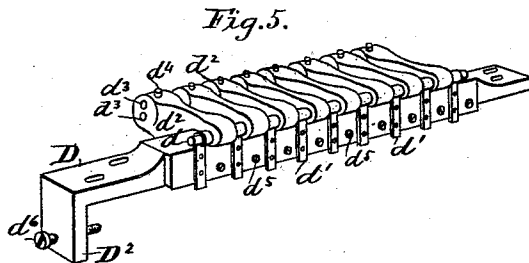
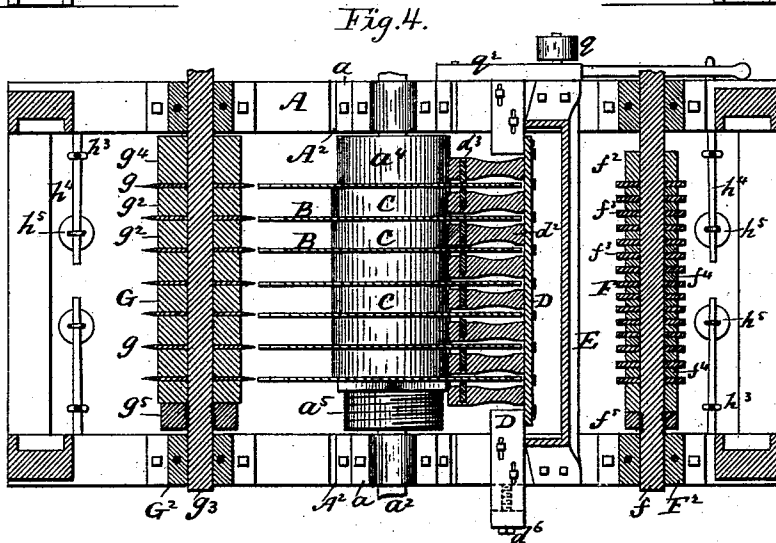
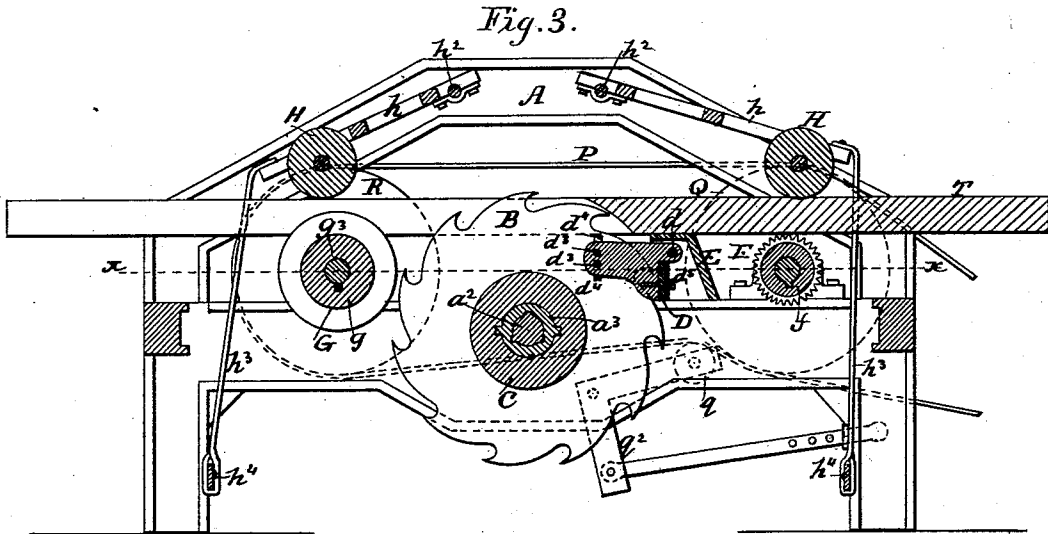

Witnesses:

Harry L. Ames
J. J. Masson

Inventor:

James O. Butler
by E. E. Masson
att'y.

UNITED STATES PATENT OFFICE.

JAMES OSCAR BUTLER, OF VERBENA, ALABAMA.

GANG CIRCULAR SAWING MACHINE.

SPECIFICATION forming part of Letters Patent No. 408,790, dated August 13, 1889.

Application filed June 23, 1888. Serial No. 277,956. (No model.)

To all whom it may concern:

Be it known that I, JAMES OSCAR BUTLER, a citizen of the United States of America, residing at Verbena, in the county of Chilton and State of Alabama, have invented certain new and useful Improvements in Gang Circular Sawing Machines, of which the following is a specification, reference being had therein to the accompanying drawings.

My invention relates to improvements in gang circular-saw mills; and the object of my improvement is to provide a machine for making straight-grain or quartered flooring at a reduced cost by obtaining with rapidity a large proportion of this class of timber from a log with but a small additional amount of manual labor. I attain these objects by the construction illustrated in the accompanying drawings, in which—

Figure 1 is a side view of a machine constructed in accordance with my invention. Fig. 2 is a top view of the same. Fig. 3 is a longitudinal vertical section of the main portion of the machine. Fig. 4 is a horizontal section on line $x x$ of Fig. 3. Fig. 5 is a perspective view of the series of fingers carrying saw-guides, their adjustable supporting-bar, and pivot-rod upon which they are mounted.

In said drawings, the frame of the machine is represented at A. The sides thereof are recessed in the middle of their length at A^2 , and in said recesses are located the bearings a for the main shaft or mandrel a^2 , that is provided with three keys on its periphery. Upon said mandrel is mounted the sleeve a^3 , having on one end the large collar a^4 and at the other end a screw-thread to receive the nut a^5 . The interior of the arbor is provided with grooves to fit upon the three keys of the mandrel, and its exterior is provided with two keys to enter corresponding recesses in the saws B and in the removable collars C, placed thereon between each saw. These collars are of any desired thickness corresponding with the thickness of the flooring-lumber intended to be obtained.

The recesses A^2 in the frame are made so as to permit the saws to be lowered and the saw-teeth to pass but very little beyond the top of the "flitches" or lumber T operated upon. This relieves the saws of the friction

and heat that would be caused upon them by the timber if the latter reached closer to their arbor; but as fast as the saws wear out and become reduced in diameter the bearings A can be elevated by placing washers or metal plates under them. Each bearing is secured to the frame by four bolts passing vertically through them, and they are also retained by bolts at their ends. The saw-guide consists in part of a rectangular bar D, located across the machine and having its middle portion standing on its edge and its ends resting flat upon the frame A. This bar carries parallel thereto, by means of straps d' , secured thereto, a cylindrical rod d , upon which are pivoted a series of fingers d^2 , the free ends of which enter between the saws. Said free ends carry two guide-pins d^3 , one of said pins being vertically above the other and bearing against one of the saws and the other pin bearing against another of the saws. Each pin is retained by a set-screw d^4 , one of which is inserted in the top of the finger and the other in the under side thereof. This arrangement of the pins d^3 and screws d^4 facilitates the independent adjustment of said pins. Each finger is also secured firmly to the supporting-bar D by means of a bolt d^5 , inserted in the pendent under side of said finger and into said bar. The base of said finger rests against said bar, and is broader than the middle portion, the latter being made thin at these points where the saw-teeth pass between the fingers. This gives space for the sawdust to escape between them without danger of choking up. The bar D is secured to the frame at each end by means of bolts passing through slots in said bars. It has also a pendent arm D², through which passes an adjusting-screw d^6 , that extends into the frame, and whereby a very minute adjustment can be made.

Over the fingers d^2 there is placed an angular bar E, having its ends secured to the frame. Said bar extends down in front of the fingers, and is to protect the fingers and form a support for the lumber passing over it, and prevents it from bending down after its rear end leaves the front feed-roll F. This roll consists of a shaft f , upon which is secured a collar f^2 near one end, a series of spur-wheels

f^3 , and a washer f^4 between each of said wheels and the next. These wheels and washers are retained clamped together against the collar f^2 by a nut f^5 at the opposite end. This shaft f is provided with a key that fits into key-seats in the spur-wheels, and prevents them from rotating independently of the shaft. Said shaft is retained in boxes F^2 , bolted to the frame of the machine.

10 In the rear of the saws there is a roll G, consisting of a series of disks g and rings g^2 between them. The edge of the disks is beveled on both sides and tapers to a feather-edge, and constitutes a continuous wedge around
15 said disks to enter the kerf made by the saws. It keeps the sawed boards apart and prevents the lumber from clamping the saws. These disks and wedges are keyed on the shaft g^3 , and are retained by means of a collar g^4 at
20 one end and a nut g^5 at the other, said shaft g^3 being retained in boxes G^2 , bolted to the frame. These wedging-rings are the same distance apart as are the saws and in line with them, and the rings g^2 constitute the
25 support at that point for the lumber. To keep said lumber pressed upon the feed-roll F and wedge-roll G smooth rollers H are suspended above them by means of frames h , pivoted at h^2 to the frame A in a horizontal
30 plane above the saws, and to add to their pressure chains or ropes h^3 are attached to the lower end of the frames h . The lower end of each of said ropes is attached to a lever h^4 , that has one end pivoted to the frame, and the opposite end carries a weight h^5 , adjustable along said lever.

At the front end of the machine there is a table I, having rollers i , to receive the lumber fed to the saws. It carries also on one
40 side a straight-edge i^2 , to properly guide one edge of said lumber. At the rear end of the machine there is also a table K, carrying two rolls k , to facilitate the removal of the lumber after it is sawed. These tables are properly secured to the frame A.

45 Power is given to the mandrel-shaft a^2 by means of broad pulleys M upon the ends of said shaft. The latter carries, also, a small pulley m , around which passes a belt n , that
50 passes around a large pulley N upon the shaft N^2 , retained in bearings on the frame of the table I. This shaft N^2 carries on the opposite end a small pulley n^3 , around which is placed a belt P, that presses with frictional
55 contact upon the large pulley Q, that is

mounted upon one end of the shaft f of the feed-roll F. Said belt passes also around a large pulley R upon the shaft g^3 of the wedges carrying roll G, and gives also motion to the latter. To cause the belt P to hug the under
60 side of the pulley Q, a belt-tightening roll q is made to press against the bottom of said belt P, said belt-tightener roll q being mounted upon one of the arms of the bell-crank lever q^2 , pivoted to the frame.

Having now fully described my invention, I claim—

1. The combination of a series of saws and collars mounted upon an arbor, a series of
70 fingers between said saws, each finger provided with two horizontal pins located vertically one above the other, and set-screws for each pin, with a bar D and finger-retaining screws d^2 , and a rod passing through all the fingers, substantially as and for the purpose
75 described.

2. The combination of a series of saws and removable collars mounted upon an arbor, a series of vertically-adjustable fingers between
80 said saws, and two horizontal pins projecting from each finger, with the transverse bar D, the rod d , and the angular protecting-bar E, extending in front thereof and over said fingers, substantially as and for the purpose described.

3. The combination of a series of saws mounted upon a sleeve secured to an arbor, and a series of fingers between said saws, each intermediate finger having two adjustably-retained pins projecting from its sides and located one vertically above the other, with a
90 feed-roll consisting of a series of spur-wheels and washers mounted upon and clamped on a shaft, substantially as and for the purpose described.

4. The combination of a series of saws mounted upon a sleeve carried by an arbor with a shaft having a series of disks and parting-rings thereupon, each disk tapering on
100 both sides adjacent to its periphery and constituting wedges to relieve the saws of pressure, and a smooth-face pressure-roll over said disks, substantially as described.

In testimony whereof I affix my signature in presence of two witnesses.

JAMES OSCAR BUTLER.

Witnesses:

W. H. FOSHEE,
JOHN GARNER.