

Jan. 25, 1966

C. M. WAGNER

3,231,730

COMBINATION TOOL TRAY AND EXTENSION LIGHT

Filed Feb. 27, 1964

2 Sheets-Sheet 1

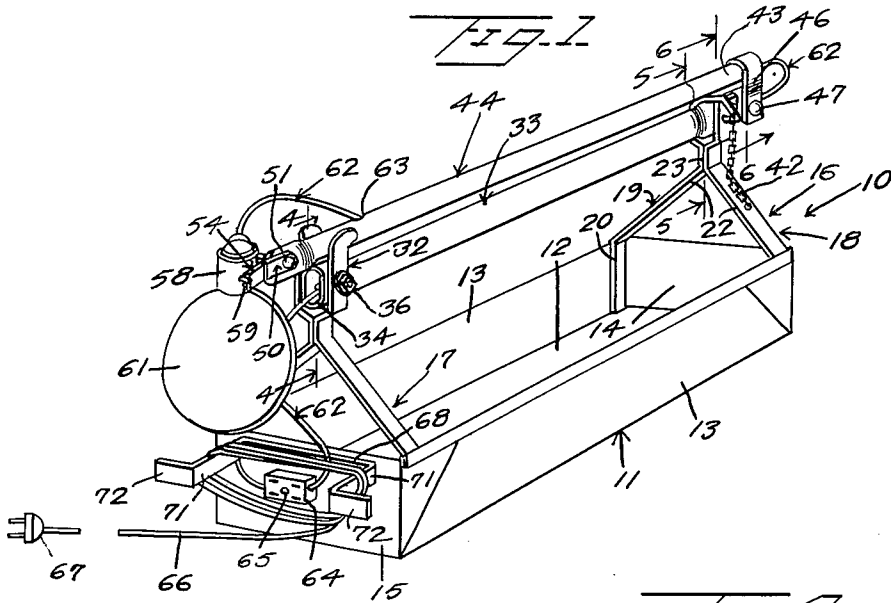

FIG. 3

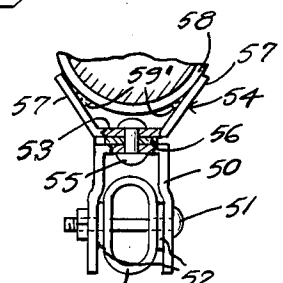

FIG. 4

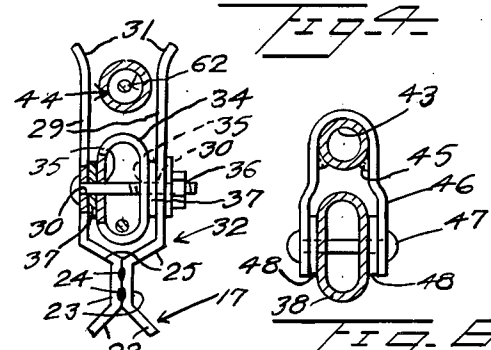

FIG. 6

FIG. 5

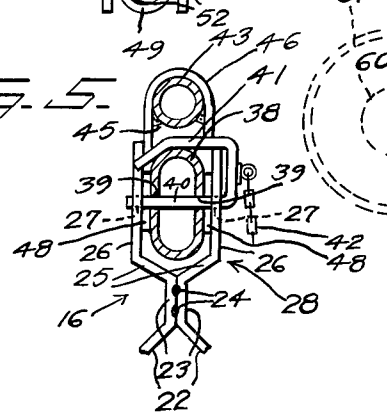
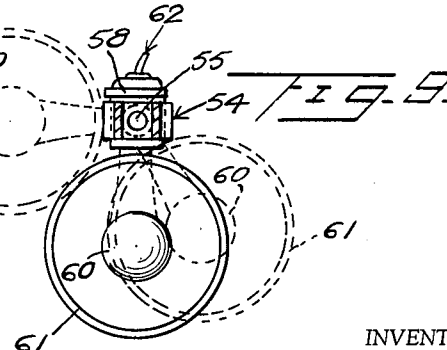

FIG. 8



INVENTOR

CLYDEM. WAGNER

BY

John N. Randolph

ATTORNEY

Jan. 25, 1966

C. M. WAGNER

3,231,730

COMBINATION TOOL TRAY AND EXTENSION LIGHT

Filed Feb. 27, 1964

2 Sheets-Sheet 2

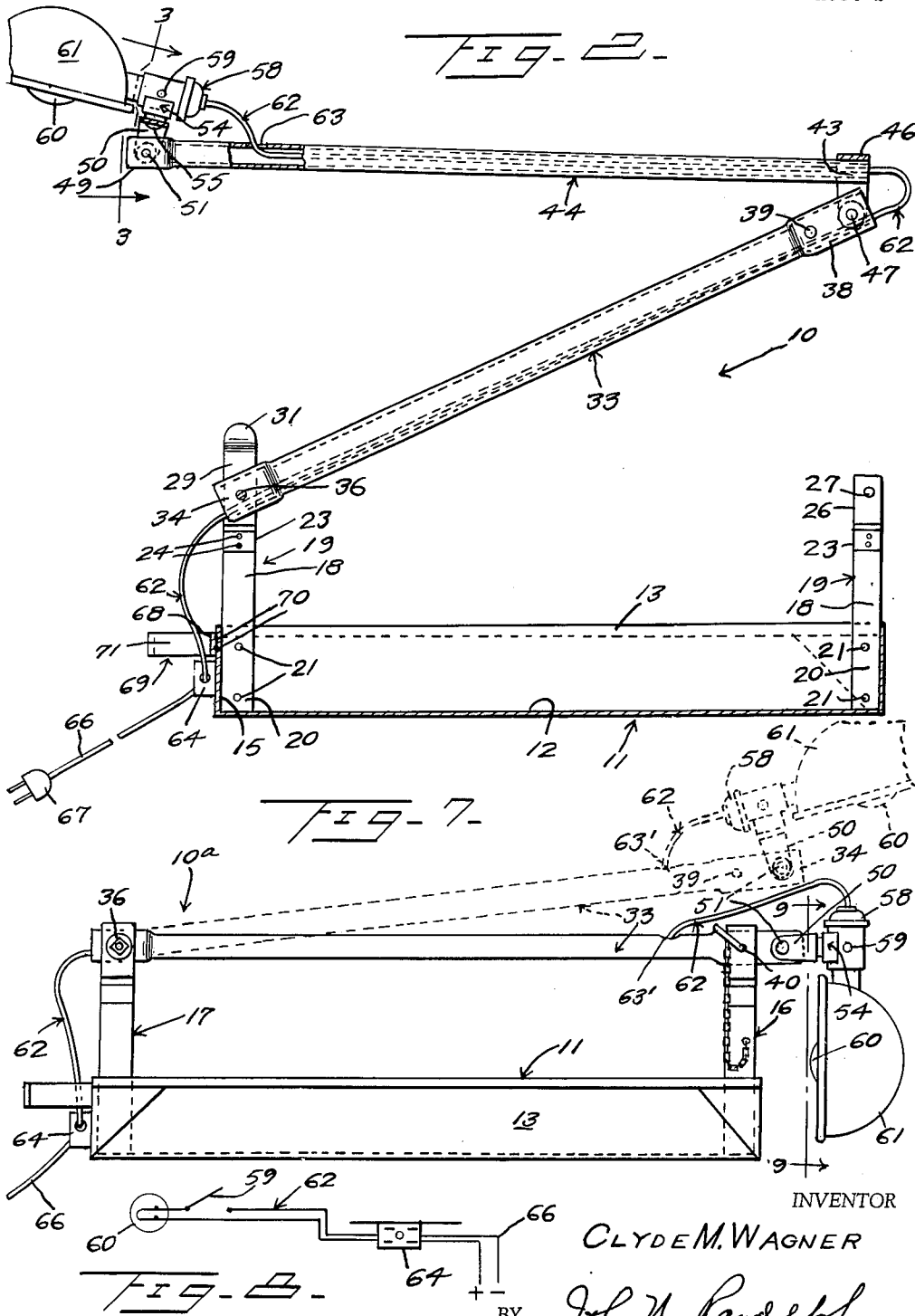

INVENTOR

Clyde M. Wagner

BY John N. Randolph

ATTORNEY

1

2

3,231,730
**COMBINATION TOOL TRAY AND EXTENSION
 LIGHT**

Clyde M. Wagner, 168 N. Sparta St.,
 Steeleville, Ill. 62288
 Filed Feb. 27, 1964, Ser. No. 347,916
 5 Claims. (Cl. 240—2)

This invention relates to a novel combination tool tray and extension light and has for its primary object to provide a tool tray equipped with an extension light, an extension cord and an electric socket.

Another object of the invention is to provide a combination tool tray and extension light wherein a part of an extensible support for the light forms a carrying handle for the tool tray, when the extension light is in a retracted or folded position.

A further object of the invention is to provide a combination tool tray and extension light wherein the light is universally mounted on an adjustable light support, to enable the light source to be most conveniently positioned for illuminating the work or an area where work is being performed.

Another object of the invention is to provide a tool tray and extension light combination wherein an electrical outlet is interposed in an extension cord of the light source and mounted on the tool tray in a position readily convenient for the attachment thereto of electric hand tools, such as drills and saws.

Various other objects and advantages of the invention will hereinafter become more fully apparent from the following description of the drawings, illustrating presently preferred embodiments thereof, and wherein:

FIGURE 1 is a perspective view of a preferred embodiment of the invention showing the extension light support latched in a folded position;

FIGURE 2 is a longitudinal substantially central sectional view, partly in elevation and partly broken away, showing the light support in an extended position;

FIGURE 3 is an enlarged fragmentary sectional view, taken substantially along the line 3—3 of FIGURE 2;

FIGURE 4 is an enlarged fragmentary cross-sectional view, taken substantially along the line 4—4, FIGURE 1;

FIGURE 5 is an enlarged transverse vertical sectional view, taken substantially along the line 5—5 of FIGURE 1;

FIGURE 6 is an enlarged cross-sectional view, taken substantially along the line 6—6 of FIGURE 1;

FIGURE 7 is a side elevational view, partly broken away, illustrating a slightly different embodiment of the invention;

FIGURE 8 is a diagrammatic view illustrating the electric circuit of either embodiment of the invention, and

FIGURE 9 is a cross-sectional view taken along the line 9—9 of FIGURE 7.

Referring more specifically to the drawings, and first with reference to FIGURES 1 to 6, the combination tool tray and extension light as illustrated therein is designated generally 10 and includes an elongated open top tool tray 11 which is preferably formed of metal and which includes a bottom 12, corresponding side walls 13, and end walls 14 and 15.

Supports 16 and 17 are fixed to and rise from end portions of the tray 11 and are disposed cross-wise thereof.

Each of said supports preferably includes two metal strap members 18 and 19 having parallel bottom portions 20 which are disposed against the side walls 13 and secured thereto in any suitable manner, as by spot welding, as indicated at 21 in FIGURE 2. The portions 20 of the support 16, in addition to engaging the inner sides of the walls 13, abut the inner side of the end wall 14, and the portions 20 of the support 17 are similarly disposed relative to the side walls 13 and the end wall 15. The strap members 18 and 19 of each support include portions 22 which converge upwardly relative to one another. The upper ends of the portions 20 terminate in abutting upright extensions 23 which are welded or otherwise secured together, as indicated at 24 in FIGURES 4 and 5. The strap members 18 and 19 of the support 16 have portions 25 which extend upwardly in diverging relation to one another from the upper ends of the portions 23, and the strap members of the support 17 have corresponding portions 25, as seen in FIGURES 5 and 4, respectively. The strap members 18 and 19 of the support 16 have transversely spaced upright terminal portions 26 which form extensions of the portions 25, and which are provided with aligned apertures 27, as seen in FIGURE 5. The parts 25 and 26 of the support 16 combine to form an upwardly opening yoke 28, constituting the upper end of said support. The support 17 has upwardly extending transversely spaced terminal portions 29 which extend from the portions 25 thereof and which likewise have aligned apertures 30, as seen in FIGURE 4. The terminal portions 29 are longer than the portions 26, for a purpose which will hereinafter be described, and have outwardly flared upper ends 31. The portions 25 and 29 form an upwardly opening yoke 32, constituting the upper end of the support 17.

An elongated, substantially rigid tube 33 has a flattened end 34 which fits in the yoke 32 and has apertures 35 which align with the apertures 30 for receiving the shank of the bolt, of a nut and bolt fastening 36, which extends through the aligned apertures 30 and 35 for pivotally connecting the tube 33 to the support 17. Friction washers 37, preferably formed of fabric, are mounted on said bolt shank between the yoke arms 29 and the tube end 34, so that when the fastening 36 is tightened the tube 33 may be forcibly pivoted relative to the support 17 but will be retained by the friction washers 37 in any angularly adjusted position to which it is moved.

The other end 38 of the tube 33 is also flattened, as seen in FIGURE 5, and a portion thereof fits detachably between the arms 26 of the yoke 28 and has apertures 39 to align with the apertures 27, to receive a pin 40 for detachably fastening the tube 33 to the support 16. As seen in FIGURE 5, the pin 40 has an angular extension 41 which is resilient and which may be sprung over a part of the tube end 38, as seen in FIGURES 1 and 5, to releasably retain the pin 40 in engagement with the openings 27 and 39. A chain or other flexible element 42 tethers the pin 40 to the strap 18 of the support 16.

On end 43 of a rigid tubular member 44 is secured, as by welding, as seen at 45 in FIGURE 6, in the tight portion of a rigid substantially U-shaped metal strap member 46 the legs of which straddle the tube end 34 and are pivotally connected thereto by a rivet 47. Washers 48, corresponding to the washers 47, are disposed on the rivet 47 between the tube end 34 and the legs of the strap

member 46 to resist swinging movement of the strap member relative to the tube 33, so that the tube 44 will be retained in different angular positions relative to the tube 33 to which it is forcibly moved, as illustrated in FIGURE 2. The strap member 46 is spaced outwardly from the pin receiving openings 35, as best illustrated in FIGURE 2.

The other end 49 of the tube 44 is flattened and disposed in a plan substantially parallel to the plane of the flattened tube ends 34 and 38. As best seen in FIGURE 3, the legs of a substantially rigid U-shaped metal strap member 50 straddle the flattened end 49 and are pivotally connected thereto by a nut and bolt fastening 51 which extends through said legs and through the part 49 and which carries friction washers 52 which are disposed between said legs and the part 49, to frictionally resist pivotal movement of the strap member 50 relative to the tube 44 and to retain said member in any position to which it is forcibly moved. The intermediate portion 53 of a yoke member 54 is swivelly connected by a rivet 55 to the outside of the intermediate portion of the strap member 50, and a friction washer 56 is interposed between the yoke 54 and strap member 50 to restrict turning movement of the yoke 54 relative to the strap member 50, so that said yoke can be retained in any position to which it is forcibly turned. The washer 56 and the washers 52 also correspond with the washers 37. The yoke 54 has outwardly diverging legs 57, constituting the ends thereof, which straddle a part of a conventional electric light socket 58 and are secured thereto, as by welding, as seen at 59' in FIGURE 3.

The socket 58 has a conventional switch 59 and supports a light bulb or light source 60 and a conventional reflector 61. A conventional electric cord 62 extends from the socket 58 into the tube 44 through an opening at 63 thereof, and thence longitudinally through the tube 44 toward and through its end 43. The light cord 62 then passes into the tube 33, through the tube end 38, and through said tube 33 and out of the end 34 thereof. A conventional electric socket 64 is interposed in and electrically connected to the electric cord 62, beyond the tube end 34, and is secured by a fastening 65 to the outer side of the end wall 15 of the tray. The electric cord 62 includes a portion 66 which extends from the socket 64 and which forms an extension cord having a conventional electrical plug 67 at its other end. The extension cord 66 may be of any desired length, preferably fifteen or twenty feet.

The intermediate portion 68 of a U-shaped strap member 69 is secured to the outer side of the wall 15, preferably above the outlet 64, as by welding, as seen at 70, in FIGURE 2. As best seen in FIGURE 1, the legs 71 of the member 69 extend outwardly from the ends of the intermediate portion 68 and have terminal portions 72 which extend away from one another. The member 29 forms a cleat on which the extension cord 66 may be wound, when not in use, as illustrated in FIGURE 1.

When the light source 60 is not being utilized, the tube 33 is latched to the support 16 by the pin 40, and the tube 44 is swung downwardly to a position substantially parallel to the tube 33, so that a part thereof will be disposed between the upper parts of the arms 29 to prevent any appreciable lateral swinging movement of the tube 44. The strap member 50 can be swung outwardly so that light bulb 60 and reflector 61 will extend downwardly from the socket 58 and with the reflector 61 facing toward the support 17, as seen in FIGURE 1. In this folded or retracted position of the extensible light support 33, 44, the tube 33 forms a carrying handle for the tray 11. By removing the pin 40 from engagement with the openings 39, the tubes 33 and 44 may be moved to different extended positions, by swinging the tube 33 upwardly relative to the support 17 and by pivoting the tube 44 upwardly relative to the tube 33. The socket 58 and the light source 60 and reflector 61, carried thereby,

may then be pivoted with parts 50 and 54 relative to the tube 44, and said socket, light source and reflector may be swivelled with the yoke 54 relative to the strap member 50, for positioning the light source 60 and reflector 61 in substantially any desired position for directing the light rays from the light source toward the work or toward an area where the work is to be performed. Thus, the light source 60 is universally mounted relative to its extensible support by which it can be extended relative to the tray 11. The socket 64 can be utilized for electrically connecting various electrical tools to the extension cord 66, so that when the plug 67 thereof is connected to a conventional electrical outlet, electric current will be supplied not only to the light source 60 but to the electric tools connected to the socket 64.

FIGURE 7 illustrated a slightly different embodiment of the invention designated generally 10a, wherein the tube 44 is omitted together with the strap member 46, and the strap member 50 is pivotally connected by its fastening 51 to the outer end of the tube portion 38. The electric cord 62 extends from the socket 58 into the tube 33 through an opening 63' thereof. The combination tool tray and extension light 10a, as illustrated in FIGURE 7, otherwise corresponds identically with the tool tray and extension light combination 10, and by removing the pin 40 the tube 33 can be pivoted upwardly relative to the support 17 for extending the light source 60. Likewise, the light source 60 may be swung with the strap 50 relative to the tube end 38 and may be turned with the yoke 54 relative to the strap 50, for universally adjusting the light source 60 and reflector 61 relative to the tube 33 and tray 11.

Various other modifications and changes are contemplated and may be resorted to without departing from the function or scope of the invention as hereinafter defined in the appended claims.

I claim as my invention:

1. A combination tool tray and extension light comprising a tool tray having an open top, a first support and a second support fixed to said tool tray and rising from the open top thereof and disposed in spaced apart relation to one another, an elongated rigid member, means pivotally connecting said rigid member to said first support for swinging movement toward and away from the tool tray, means detachably connecting said rigid member to said second support in a folded or retracted position of said member whereby a part of said member, disposed between said supports, constitutes a carrying handle for the tool tray, a light source, and means connecting said light source to an end of said rigid member disposed remote from said first support for angular adjustment of the light source relative to said rigid member about at least two axes which are disposed at an angle to one another.

2. A combination as defined by claim 1, said means connecting the light source to said rigid member including a long rigid element interposed between two of said axes.

3. A combination as defined by claim 2, said rigid element being pivotally connected to said rigid member for swinging movement about one of said axes, said light source being pivotally connected for swinging movement relative to said rigid element about a second one of said axes and remote from said first mentioned axis, and a swivel connection interposed between said second axis and the light source and constituting a third one of said axes.

4. The combination of a tool tray having an open top, a light source, articulated means connected at one end to the tray and having an opposite end on which the light source is supported for extending and retracting the light source relative to said tray, means attaching the light source to said articulated means for angularly adjusting the light source relative to the articulated means and the tray about two axes which are angularly disposed relative to one another, and means releasably latching a part of said articulated means to the tray whereby a portion

5

of the articulated means, disposed above said open top, forms a carrying handle for the tool tray.

5. A combination as defined by claim 4, one of said two axes constituting a swivel connection disposed between the light source and the other of said two axes.

5

References Cited by the Examiner

UNITED STATES PATENTS

2,207,017	7/1940	Lemmerman	-----	240—6.4	
2,745,949	5/1956	Borin	-----	240—81	10
2,850,622	9/1958	Johnson	-----	240—81	
3,026,409	3/1962	Deisch	-----	240—81	X

6

3,053,978	9/1962	Rhoades	-----	240—52.3	X
3,116,025	12/1963	Smaltz	-----	240—10.63	X

FOREIGN PATENTS

244,398	4/1963	Australia.
1,175,135	11/1958	France.

OTHER REFERENCES

Kunz, German printed application No. 1,122,166; published Jan. 18, 1962.

NORTON ANSHER, *Primary Examiner*.