



INTERNATIONAL APPLICATION PUBLISHED UNDER THE PATENT COOPERATION TREATY (PCT)

<p>(51) International Patent Classification ⁵ : B01D 27/10, F01M 11/03</p>	<p>A1</p>	<p>(11) International Publication Number: WO 92/18219 (43) International Publication Date: 29 October 1992 (29.10.92)</p>
<p>(21) International Application Number: PCT/SE91/00266 (22) International Filing Date: 15 April 1991 (15.04.91)</p> <p>(71)(72) Applicant and Inventor: BJÖRNSSON, Aegir [SE/SE]; Vallgatan 17, S-450 43 Smögen (SE).</p> <p>(74) Agents: GRAUDUMS, Valdis et al.; Albihn West AB, Box 142, S-401 22 Göteborg (SE).</p> <p>(81) Designated States: AT, AT (European patent), AU, BB, BE (European patent), BF (OAPI patent), BG, BJ (OAPI pa- tent), BR, CA, CF (OAPI patent), CG (OAPI patent), CH, CH (European patent), CM (OAPI patent), DE, DE (European patent), DK, DK (European patent), ES, ES (European patent), FI, FR (European patent), GA (OA- PI patent), GB, GB (European patent), GR (European patent), HU, IT (European patent), JP, KP, KR, LK, LU, LU (European patent), MC, MG, ML (OAPI patent), MR (OAPI patent), MW, NL, NL (European patent), NO, PL, RO, SD, SE, SE (European patent), SN (OAPI patent), SU, TD (OAPI patent), TG (OAPI patent), US.</p>		<p>Published <i>With international search report.</i> <i>In English translation (filed in Swedish).</i></p>

(54) Title: FILTER APPARATUS FOR CLEANING OIL**(57) Abstract**

An arrangement for a filter for purification of oil, for example combustion oil, lubricating oil, hydraulic oil or transformer oil, from liquid and particulate impurities which are in suspension, said filter (10) being formed of a filter paper, wound into a roll (12) around a stiff core (11) of a liquid-impermeable material. Further the filter unit is provided with a surrounding housing (13) of liquid-impermeable material which is arranged to guide the liquid flow essentially axially through the filter roll (12) from a high pressure side to a low pressure side. With a view to increasing the field of application the core (11) is provided with an internal plug (19) proximate the low pressure side of the filter roll. Moreover the core presents a number of radial passages (26) between the core interior and the filter roll (12). Further, the core (11) is provided with at least one openable valve (25; 27), with the help of which the interior of the core can be put in flow-connection with the filter roll's (12) low pressure side.

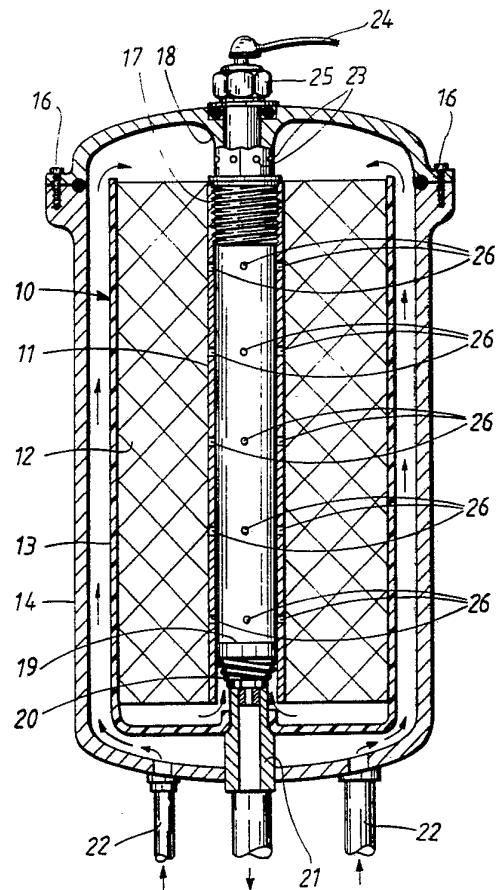

FOR THE PURPOSES OF INFORMATION ONLY

Codes used to identify States party to the PCT on the front pages of pamphlets publishing international applications under the PCT.

AT	Austria	ES	Spain	MG	Madagascar
AU	Australia	FI	Finland	ML	Mali
BB	Barbados	FR	France	MN	Mongolia
BE	Belgium	GA	Gabon	MR	Mauritania
BF	Burkina Faso	GB	United Kingdom	MW	Malawi
BG	Bulgaria	GN	Guinea	NL	Netherlands
BJ	Benin	GR	Greece	NO	Norway
BR	Brazil	HU	Hungary	PL	Poland
CA	Canada	IT	Italy	RO	Romania
CF	Central African Republic	JP	Japan	RU	Russian Federation
CG	Congo	KP	Democratic People's Republic of Korea	SD	Sudan
CH	Switzerland	KR	Republic of Korea	SE	Sweden
CI	Côte d'Ivoire	LI	Liechtenstein	SN	Senegal
CM	Cameroon	LK	Sri Lanka	SU	Soviet Union
CS	Czechoslovakia	LU	Luxembourg	TD	Chad
DE	Germany	MC	Monaco	TC	Togo
DK	Denmark			US	United States of America

TITLE

FILTER APPARATUS FOR CLEANING OIL

TECHNICAL FIELD

The present invention concerns an arrangement for a filter for the purification of oil, for example combustion oil, lubricating oil, hydraulic oil or transformer oil from liquid and particulate impurities which are in suspension, said filter being formed of a filter paper, wound into a roll around a stiff core of a liquid-impermeable material, and a housing, surrounding the filter unit, of liquid-impermeable material which is arranged to guide the liquid flow essentially axially through the filter roll from a high pressure side to a low pressure side.

TECHNICAL BACKGROUND

GB 796,475 describes an oil filter which for a long time formed the market standard in the category of lubrication filters. The development in combustion engines has, at least for private cars and trucks, gone in a direction towards engines with higher performance and higher operating temperatures. The requirements on the lubrication oil's quality and the system for purification of the same have also increased accordingly. In many cases the problem is solved with the help of more frequent oil and filter changes. The high quality oil contains many chemical additives which make it expensive to produce and at the same time imply a load on the environment. Used lubrication oil is often destroyed by burning in plants having poor or no cleaning. The normal reason necessitating the change of lubrication oil is that the oil is saturated with fine particles which the engine's filter system is incapable of collecting.

The increased use of hydraulic oil for different systems and arrangements also brings with it a considerable load on the

environment, for example when piston seals are damaged by particles in the oil, leading to leaks.

Another field of use for oil is as insulating fluid in transformers. Due to the occurrence of particles and moisture in the oil, arcing can occur in the fluid. The insulating fluid therefore has to be changed or filtered clean at regular intervals.

SE 450 650 describes an arrangement for filtering of combustion oil for diesel engines. The arrangement accomplishes an effective separation of particles and water droplets from the combustion oil but, due to the large flow resistance, this arrangement has a limited field of application.

Present filter arrangements lack the flexibility required to be effective at differing oil temperatures, viscosities and degrees of impurity.

TECHNICAL PROBLEM

An object of the present invention is therefore to achieve a filter arrangement which is more adaptable to different conditions of use than known filter arrangements. Another object is to achieve a highly effective filter arrangement for a broad spectrum of applications.

SOLUTION

This object is achieved according to the invention, in that the core is provided with an internal plug proximate the low pressure side of the filter roll, in that the core presents a number of radial passages between the core interior and the filter roll, and in that the core moreover is provided with at least one openable valve, with the help of which the interior of the core can be put in flow-connection with the filter roll's low pressure side.

The subsequent dependent claims describe different advantageous variants of the arrangement.

DESCRIPTION OF THE FIGURES

An embodiment of the invention will now be described in more detail with reference to the accompanying drawings, in which

Fig.1 schematically shows a vertical section of a filter arrangement according to a first embodiment of the invention, and

Fig.2 shows a variation of the filter arrangement depicted in Fig.1.

PREFERRED EMBODIMENTS

Both figures show a filter arrangement comprising a central filter insert 10, which presents a core 11 of oil-resistant material, around which cellulose paper is tightly wound into a roll 12. This roll is pressed into a filter holder bowl 13 which fits tightly against the roll's enveloping surface, but leaves free play at one end of the roll, which in the figure is the lower end. The other end of the roll is totally open.

The filter insert 10 is mounted inside a filter housing 14. The casing 14 comprises a cover 15, which is screwably tightenable by means of screws 16 in a cylindrical part. The core 11 of the filter insert 10 is screwed onto a centrally positioned sleeve 18 provided with external threads 17 and projecting from the inside of the cover 15. The opposite end of the insert 10 is supported by means of an end plug 19, a compression spring 20 and additionally a central opening in the filter holder bowl 13 against a pipe socket 21 directed towards the interior of the container. This pipe socket 21 connected tightly against the filter holder bowl 13 forms an outlet from the filter housing 14.

The housing 14 is provided with two inlet pipes 22, which open onto the outside of the filter housing bowl 13. Hereby a flow path is formed through the filter housing, which extends upwards in the figures, between the interior of the housing and the outside of the filter holder bowl to the filter housing cover. Here the flow reverses downwards and passes through the

roll 12. At the bottom of the filter holder bowl 13 the flow direction changes radially inwards and exits out of the filter housing via the central pipe socket 21.

The above described flow path forms a primary flow path through the filter, which is capable of removing all types of coarse grain and fine grain particles from the lubricating oil. Moreover this filter is capable of absorbing possible water droplets in the oil. The primary flow path through the filter roll 12 presents a proportionately large resistance to flow.

The sleeve 18 is provided with internal passages 23, which are openable by means of adjusting device 25 operable via an electric cable 24. This adjustment device can be arranged to keep the passages into the interior of the core 11 open, until the oil reaches a particular temperature, or alternatively to open the passages 23 in case the fluid pressure on the filter's pressure side reaches a particular value. In this way a secondary flow path is formed via the core interior and a number of holes 26 bored radially through the core wall.

Fig.1 shows a variant of the invention where all the holes 26 are open to the roll 12. This variant can be used to advantage for filtering lubrication oil, in which the secondary flow path with proportionately low resistance is open for cold starting since the oil is cold and the viscosity is therefore high. Consequently the oil passes more easily and more quickly through the filter with a reduced degree of purification, until the temperature rises and the viscosity falls, whereby the passages 23 are closed to attain the full degree of purification. This variant is even applicable for purifying hydraulic or transformer oil, in which case one uses both the primary and the secondary flow paths in a first coarse purification stage. In the second stage the filter's maximum purification capacity is then used via the primary flow path only.

Fig.2 shows a second variant of the invention where the core is divided axially by means of four valve plugs 27. Each of these valve plugs 27 is provided with an overflow valve 28 which is arranged to open at a particular fluid pressure. In this way one can thereby produce a stepwise increase or decrease of the number of open passages 26 in the core 11. This allows an extraordinarily good utilisation of the filter roll's purification capacity, which for example is shown in that dirt particles will be relatively evenly spread in the roll's axial direction.

The invention is not limited to the above described embodiment, many variations being imaginable within the scope of the following claims, For example the filter housing can be shaped differently than shown. The flow paths can be reversed from those described above. Furthermore the device for opening and closing of the secondary flow paths can be different than shown.

CLAIMS

1. An arrangement for a filter for the purification of oil, for example combustion oil, lubricating oil, hydraulic oil or transformer oil from liquid and particulate impurities which are in suspension, said filter (10) being formed of a filter paper, wound into a roll (12) around a stiff core (11) of a liquid-impermeable material, and a housing (13), surrounding the filter unit, of liquid-impermeable material which is arranged to guide the liquid flow essentially axially through the filter roll (12) from a high pressure side to a low pressure side, characterized in that the core (11) is provided with an internal plug (19) proximate the low pressure side of the filter roll, in that the core presents a number of radial passages (26) between the core interior and the filter roll (12), and in that the core (11) moreover is provided with at least one openable valve (25;27), with the help of which the interior of the core can be put in flow-connection with the filter roll's (12) low pressure side.

2. Arrangement according to claim 1, characterized in that a valve (25) is situated proximate the filter roll's (12) high pressure side.

3. Arrangement according to claim 2, characterized in that the valve (25) is adjustable to or from a first operating position, in which all the oil passes axially through the filter roll, to a second operating position, in which the oil can also flow radially into the filter roll via the passages (26).

4. Arrangement according to claim 1 or 2, characterized in that the passages (26) are separated along the core (11) in the longitudinal direction with a certain mutual distance.

5. Arrangement according to claim 4, characterized in that the interior of the core

(11) is divided in the axial direction by means of valves (27, 28) which are placed between the passages.

6. Arrangement according to claim 5, characterized in that the valves (28) are formed as overflow valves, which are arranged to open at predetermined over-pressure, such that the core's interior can be opened successively in the axial direction with increasing overpressure, in order to open more and more radially directed passages (26) to the filter roll (12).

1/2

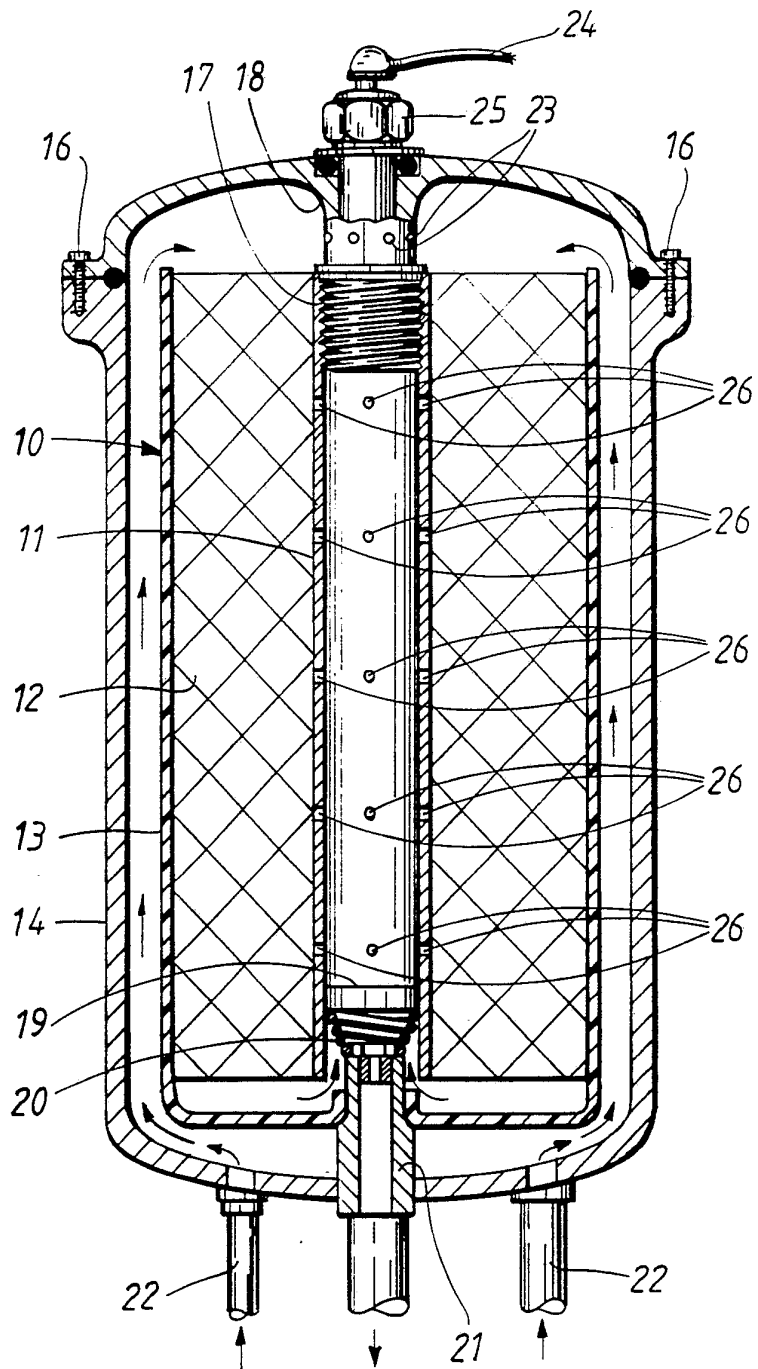

FIG. 1

2/2

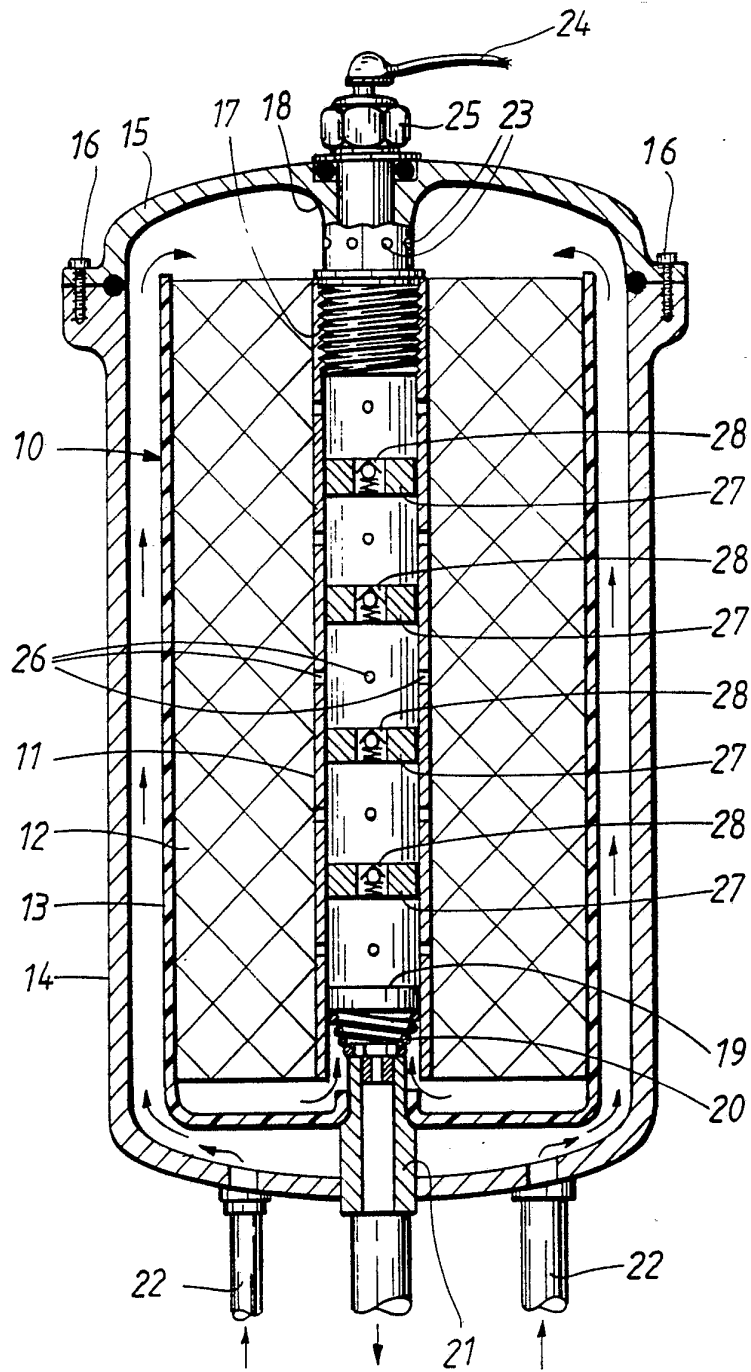
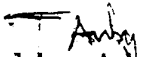

FIG. 2

INTERNATIONAL SEARCH REPORT

International Application No PCT/SE 91/00266

I. CLASSIFICATION OF SUBJECT MATTER (if several classification symbols apply, indicate all) ⁶ According to International Patent Classification (IPC) or to both National Classification and IPC IPC5: B 01 D 27/10, F 01 M 11/03				
II. FIELDS SEARCHED Minimum Documentation Searched ⁷				
Classification System	Classification Symbols			
IPC5	B 01 D; F 01 M			
Documentation Searched other than Minimum Documentation to the Extent that such Documents are Included in Fields Searched ⁸				
SE,DK,FI,NO classes as above				
III. DOCUMENTS CONSIDERED TO BE RELEVANT⁹				
Category *	Citation of Document, ¹¹ with indication, where appropriate, of the relevant passages ¹²	Relevant to Claim No. ¹³		
A	WO, A1, 8603687 (SELSDON, LESLIE, DONALD) 3 July 1986, see figure 1 ---	5,6		
A	GB, A, 2204250 (EIICHI SUGIURA) 9 November 1988, see the whole document -----	1		
<table style="width: 100%; border: none;"> <tr> <td style="width: 50%; vertical-align: top; border: none;"> <p>* Special categories of cited documents: ¹⁰</p> <p>"A" document defining the general state of the art which is not considered to be of particular relevance</p> <p>"E" earlier document but published on or after the international filing date</p> <p>"L" document which may throw doubts on priority claim(s) or which is cited to establish the publication date of another citation or other special reason (as specified)</p> <p>"O" document referring to an oral disclosure, use, exhibition or other means</p> <p>"P" document published prior to the international filing date but later than the priority date claimed</p> </td> <td style="width: 50%; vertical-align: top; border: none;"> <p>"T" later document published after the international filing date or priority date and not in conflict with the application but cited to understand the principle or theory underlying the invention</p> <p>"X" document of particular relevance, the claimed invention cannot be considered novel or cannot be considered to involve an inventive step</p> <p>"Y" document of particular relevance, the claimed invention cannot be considered to involve an inventive step when the document is combined with one or more other such documents, such combination being obvious to a person skilled in the art.</p> <p>"&" document member of the same patent family</p> </td> </tr> </table>			<p>* Special categories of cited documents: ¹⁰</p> <p>"A" document defining the general state of the art which is not considered to be of particular relevance</p> <p>"E" earlier document but published on or after the international filing date</p> <p>"L" document which may throw doubts on priority claim(s) or which is cited to establish the publication date of another citation or other special reason (as specified)</p> <p>"O" document referring to an oral disclosure, use, exhibition or other means</p> <p>"P" document published prior to the international filing date but later than the priority date claimed</p>	<p>"T" later document published after the international filing date or priority date and not in conflict with the application but cited to understand the principle or theory underlying the invention</p> <p>"X" document of particular relevance, the claimed invention cannot be considered novel or cannot be considered to involve an inventive step</p> <p>"Y" document of particular relevance, the claimed invention cannot be considered to involve an inventive step when the document is combined with one or more other such documents, such combination being obvious to a person skilled in the art.</p> <p>"&" document member of the same patent family</p>
<p>* Special categories of cited documents: ¹⁰</p> <p>"A" document defining the general state of the art which is not considered to be of particular relevance</p> <p>"E" earlier document but published on or after the international filing date</p> <p>"L" document which may throw doubts on priority claim(s) or which is cited to establish the publication date of another citation or other special reason (as specified)</p> <p>"O" document referring to an oral disclosure, use, exhibition or other means</p> <p>"P" document published prior to the international filing date but later than the priority date claimed</p>	<p>"T" later document published after the international filing date or priority date and not in conflict with the application but cited to understand the principle or theory underlying the invention</p> <p>"X" document of particular relevance, the claimed invention cannot be considered novel or cannot be considered to involve an inventive step</p> <p>"Y" document of particular relevance, the claimed invention cannot be considered to involve an inventive step when the document is combined with one or more other such documents, such combination being obvious to a person skilled in the art.</p> <p>"&" document member of the same patent family</p>			
IV. CERTIFICATION				
Date of the Actual Completion of the International Search	Date of Mailing of this International Search Report			
7th November 1991	1991 -11- 8			
International Searching Authority	Signature of Authorized Officer			
SWEDISH PATENT OFFICE	 Johan Auby			

**ANNEX TO THE INTERNATIONAL SEARCH REPORT
ON INTERNATIONAL PATENT APPLICATION NO.PCT/SE 91/00266**

This annex lists the patent family members relating to the patent documents cited in the above-mentioned international search report. The members are as contained in the Swedish Patent Office EDP file on **91-09-27**.
The Swedish Patent Office is in no way liable for these particulars which are merely given for the purpose of information.

Patent document cited in search report	Publication date	Patent family member(s)	Publication date
WO-A1- 8603687	86-07-03	GB-A-B- 2141354	84-12-19
		US-A- 4832836	89-05-23
		AU-B- 585208	89-06-15
		AU-D- 3833085	86-07-22
		EP-A-B- 0148535	85-07-17
		EP-A-B- 0243346	87-11-04
		GB-A- 2152658	85-08-07
		JP-A- 60216877	85-10-30
		-----	-----
GB-A- 2204250	88-11-09	DE-A- 3803761	88-12-01
		JP-A- 63278512	88-11-16