



(22) Date de dépôt/Filing Date: 2001/06/05

(41) Mise à la disp. pub./Open to Public Insp.: 2002/12/05

(45) Date de délivrance/Issue Date: 2007/01/16

(51) Cl.Int./Int.Cl. *A63C 11/22* (2006.01)

(72) Inventeurs/Inventors:
BUJOLD, EDWARD J., US;
WISE, EUGENE P., US

(73) Propriétaires/Owners:
BUJOLD, EDWARD J., US;
WISE, EUGENE P., US

(74) Agent: FURMAN & KALLIO

(54) Titre : POTEAU DE SPORT SECURITAIRE

(54) Title: SAFETY ATHLETIC POLE

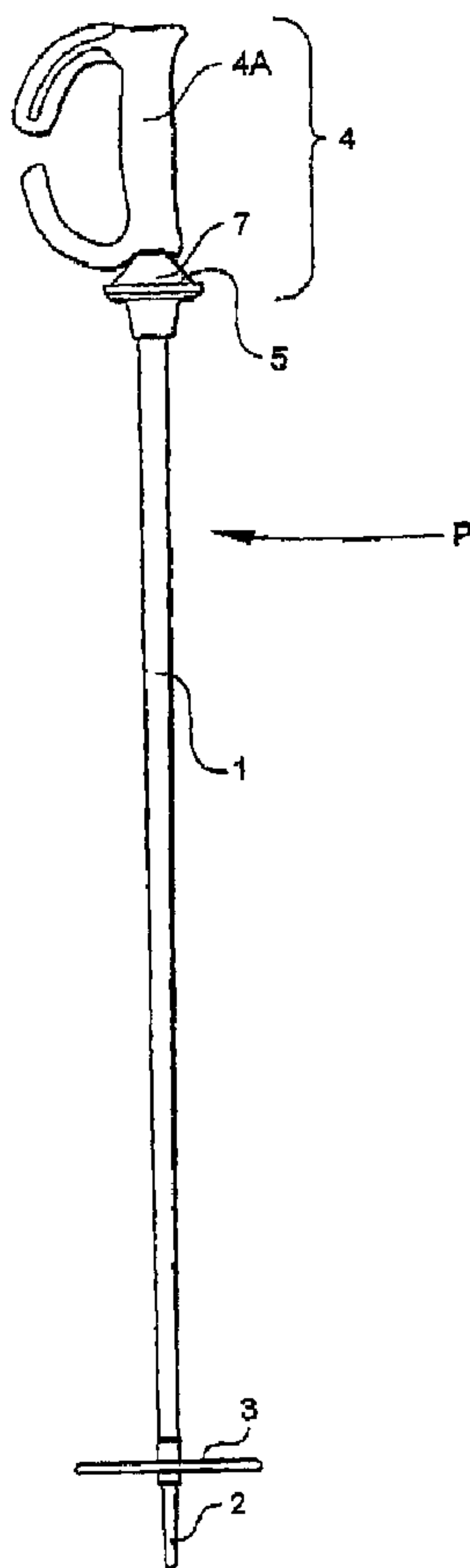

(57) Abrégé/Abstract:

An athletic pole including a handle, a shaft, and a handle-to-shaft transition assembly, said transition assembly adapted for allowing the handle to articulate. The transition assembly includes an enlarged shaft base on the shaft, the shaft base including a handle-

(57) **Abrégé(suite)/Abstract(continued):**

base-engaging surface. The transition assembly also includes an enlarged handle base on the handle. The handle base and the shaft base are biased together by a tension force into a mating, coaxially aligned position when any bending forces applied to the pole are insufficient to overcome the tension force, the handle being pivotable to an articulated position relative to the shaft upon the application of a predetermined bending force on the pole sufficient to overcome the tension force. During handle articulation, the enlarged dimensions of the handle base and the shaft base allow the periphery of the handle base to travel across and engage the handle-base-engaging surface of the shaft base such that, after an initial range of handle articulation, the bending force necessary to continue articulation or to maintain the handle in a desired articulated position is reduced relative to the bending force that would prevail if the periphery of the handle base were not allowed to travel across the handle-base-engaging surface toward the center of the shaft base.

Abstract of the Disclosure

An athletic pole including a handle, a shaft, and a handle-to-shaft transition assembly, said transition assembly adapted for allowing the handle to articulate. The transition assembly includes an enlarged shaft base on the shaft, the shaft base including a handle-base-engaging surface. The transition assembly also includes an enlarged handle base on the handle. The handle base and the shaft base are biased together by a tension force into a mating, coaxially aligned position when any bending forces applied to the pole are insufficient to overcome the tension force, the handle being pivotable to an articulated position relative to the shaft upon the application of a predetermined bending force on the pole sufficient to overcome the tension force. During handle articulation, the enlarged dimensions of the handle base and the shaft base allow the periphery of the handle base to travel across and engage the handle-base-engaging surface of the shaft base such that, after an initial range of handle articulation, the bending force necessary to continue articulation or to maintain the handle in a desired articulated position is reduced relative to the bending force that would prevail if the periphery of the handle base were not allowed to travel across the handle-base-engaging surface toward the center of the shaft base.

SAFETY ATHLETIC POLE

Technical Field and Background of the Invention

The invention described herein is a safety athletic pole designed for use in a variety of athletic activities including, among others, hiking and skiing. To maximize clarity but without imposing a limitation, discussion of the invention is hereafter directed toward its potential embodiment as a ski pole.

10 The traditional ski pole is composed of a handle, a long, thin, rigid shaft with a pointed tip, and a basket near the tip to restrict snow penetration. The ski pole assists skiers in maneuvering efficiently in various skiing terrains and under an assortment of snow and terrain conditions. While using ski poles, a skier, whether skiing downhill or cross country, may sustain significant injuries from the simplest of falls. To minimize this danger, novice skiers are taught to release their poles
15 or attempt to keep their arms close to their body. Recent ski pole handle design attempts to make release easier, but experience indicates that, in actuality, little has been done to prevent a number of ski pole-related upper extremity injuries.

20 When falling, the natural tendency is to hold the poles tighter and brace the fall with outstretched arms. The resulting positions put the thumb at a significant biomechanical disadvantage. Abnormal forces applied to the thumb in this manner often cause injury to the

ligamentous tendon complex, joint capsule, and bones. One of the most disabling injuries often acquired from such a fall is a complete tear of the ulna collateral ligament of the thumb. Statistically, this injury ranks as the second most common reported injury in skiing (knee injuries ranking first). If one includes unreported injuries, it may be the most common injury in skiing.

5 Many skiers we have interviewed have spent six to nine months recovering from injured thumbs for which they never sought medical attention. At first glance, these injuries seem innocuous to those outside of the medical profession. Unfortunately, this is not the case. Simple tasks like holding a cup of coffee are impossible for most skiers suffering from these injuries. Tasks that require motion of a thumb injured in this manner are difficult if not impossible to perform.

10 The present invention helps prevent these debilitating injuries by incorporating an articulated break-over mechanism into the pole design. The break-over mechanism allows the pole handle to articulate when an abnormally high bending force is applied to the handle, as in an accident. The break-over mechanism includes mating handle and shaft bases that are radially enlarged relative to the shaft. Prior to and during initial handle articulation, this radial enlargement of the mating handle
15 and shaft bases enhances pole stability and integrity by distancing the fulcrum point of the articulation mechanism from the pole axis. As the handle approaches full articulation, the enlarged handle and shaft bases further enhance pole stability and integrity by reducing the distance from the fulcrum point to the pole axis, thereby reducing spring actuation. Both the enlarged handle and shaft bases and the movable fulcrum point they provide render the invention both distinguishable from
20 and superior to the prior art.

In addition, the invention improves on similar prior art ski poles by providing a system of splines and spline-receiving grooves in the enlarged handle and shaft bases that minimizes potential

misindexing of the handle and pole both when the handle is unarticulated and in all stages of handle deflection.

Summary of the Invention

Therefore, it is an object of the invention to provide an athletic pole that provides enhanced
5 user safety.

It is another object of the invention to provide an athletic pole with an articulating break-over feature that permits handle articulation when an abnormally high bending force is applied by the user.

It is another object of the invention to provide an athletic pole that permits the user to adjust
10 the tension between the articulating pole handle and the pole shaft.

It is another object of the invention to provide an athletic pole with an articulating break-over mechanism that reduces the tension between the articulating pole handle and the pole shaft after initial articulation of the handle.

It is another object of the invention to provide an athletic pole with an articulating break-over
15 mechanism that maximizes pole stability and minimizes pole stress during articulation.

It is another object of the invention to provide an athletic pole that limits rotational motion of the handle relative to the shaft.

It is another object of the invention to provide an athletic pole with a handle and a shaft that retain coaxial orientation when normal bending forces are applied to the handle.

20 These objects of the present invention are achieved in the preferred embodiments disclosed below by providing an athletic pole including a handle, a shaft, and a handle-to-shaft transition assembly, the transition assembly being adapted for allowing the handle to articulate and for

minimizing rotational motion of the handle relative to the shaft during pole operation. The transition assembly includes an enlarged shaft base on the shaft and an enlarged handle base on the handle. The shaft base includes a handle-base-engaging surface, a raised alignment post on the handle-base-engaging surface, axial splines formed with the alignment post, and radial splines extending along the handle-base-engaging surface of the shaft base. The handle base includes a shaft-base-engaging surface having spline grooves complementary to the radial splines and the axial splines of the shaft base. The shaft-base-engaging surface also includes spline groove pairs parallel to and flanking radial portions of the the spline grooves, wherein the spline groove pairs receive the axial splines that flank the particular axial spline received by a radial portion of a spline groove during a particular handle articulation. The handle base also includes axial extensions of the radial portions of the spline grooves. The extensions engage the radial splines of the shaft base during handle articulation.

According to one preferred embodiment of the invention, the radial splines are formed with the handle-base-engaging surface and the axial splines.

According to another preferred embodiment of the invention, the shaft base also includes a narrow circumferential annulus for the handle base to seat upon during unarticulated operation.

According to yet another preferred embodiment of the invention, the shaft base also includes a ramp to facilitate movement of the handle base onto the annulus following handle articulation.

According to yet another preferred embodiment of the invention, the shaft base also includes a rim around the periphery of the shaft base. The rim limits the movement of the handle base across the shaft base by forming an outer boundary of the handle-base-engaging surface, and, upon release of the handle, the rim assists the handle in resuming a normal coaxial position relative to the shaft.

According to yet another preferred embodiment of the invention, the handle-base-engaging surface, the shaft-base-engaging surface, the rim, and the alignment post are annular.

According to yet another preferred embodiment of the invention, the handle base is conical.

5 According to yet another preferred embodiment of the invention, the handle base is fixedly secured to the handle.

According to yet another preferred embodiment of the invention, the spline grooves in the shaft-engaging-surface of the handle base comprise radial portions, radial-to-axial transition portions, and axial portions.

10 According to one preferred embodiment of the invention, an athletic pole including a handle, a shaft, and a handle-to-shaft transition assembly, the transition assembly being adapted for allowing the handle to articulate and for minimizing rotational motion of the handle relative to the shaft during pole operation. The transition assembly includes an enlarged shaft base on the shaft and an enlarged, conical handle base fixedly secured to the handle. The shaft base includes an annular handle-base-engaging surface, a raised, annular alignment post on the handle-base-engaging surface, axial splines
15 formed with the alignment post, and radial splines extending along the handle-base-engaging surface of the shaft base and formed with the handle-base-engaging surface and the axial splines. The handle base includes an annular shaft-base-engaging surface having spline grooves complementary to the radial splines and the axial splines of the shaft base. The shaft-base-engaging surface also includes spline groove pairs parallel to and flanking radial portions of the spline grooves, wherein
20 the spline groove pairs receive the axial splines that flank the particular axial spline received by a radial portion of a spline groove during a particular handle articulation. The handle base also

includes axial extensions of the radial portions of the spline grooves. The extensions engage the radial splines of the shaft base during handle articulation.

According to yet another preferred embodiment of the invention, the shaft base also includes an annular rim around the periphery of the shaft base. The rim limits the movement of the handle base across the shaft base by forming an outer boundary of the handle-base-engaging surface, and, upon release of the handle, the rim assists the handle in resuming a normal coaxial position relative to the shaft.

According to one preferred embodiment of the invention, including a handle, a shaft, and a handle-to-shaft transition assembly, the transition assembly being adapted for allowing the handle to articulate and for minimizing rotational motion of the handle relative to the shaft during pole operation. The transition assembly includes an enlarged shaft base on the shaft and an enlarged, conical handle base fixedly secured to the handle. The shaft base includes an annular handle-base-engaging surface, a raised, annular alignment post on the handle-base-engaging surface, axial splines formed with the alignment post, and radial splines extending along the handle-base-engaging surface of the shaft base and formed with the handle-base-engaging surface and the axial splines. The shaft base also includes a narrow circumferential annulus for the handle base to seat upon during unarticulated operation, a ramp to facilitate movement of the handle base onto the annulus following handle articulation, and an annular rim around the periphery of the shaft base. The rim limits the movement of the handle base across the shaft base during handle articulation by forming an outer boundary of the handle-base-engaging surface, and, upon release of the handle, the rim assists the handle in resuming a normal coaxial position relative to the shaft. The handle base includes an annular shaft-base-engaging surface having spline grooves complementary to the radial splines and

the axial splines of the shaft base. The spline grooves include radial portions, radial-to-axial transition portions, and axial portions. The shaft-base-engaging surface also includes spline groove pairs parallel to and flanking the radial portions of the spline grooves, wherein the spline groove pairs receive the axial splines that flank the particular axial spline received by a radial portion of a spline groove during a particular handle articulation. The handle base also includes axial extensions of the radial portions of the spline grooves. The extensions engage the radial splines of the shaft base during handle articulation.

Brief Description of the Drawings

Some of the objects of the invention have been set forth above. Other objects and advantages of the invention will appear as the description proceeds when taken in conjunction with the following drawings, in which:

Figure 1 is a side elevation of the athletic pole with the break-over mechanism located between the handgrip and the pole shaft;

Figure 2 is a fragmentary vertical cross-section of a preferred embodiment of the invention with a compression spring located in the handle, as it is adapted to large diameter, hollow shafts;

Figure 2A is a vertical cross-section of the spring cap used to anchor the upper end of the compression spring in the pole handle;

Figure 3 is a fragmentary vertical cross-section showing a variation of the preferred embodiment of the invention as it is adapted to small diameter, solid shafts;

Figure 4 is a series of sequential, fragmentary vertical cross-section views that illustrates the operation of the articulated break-over mechanism as it goes through stages of handle articulation relative to the pole shaft;

Figure 5 is a fragmentary vertical cross-section that shows an arrangement permitting adjustment of the articulation resistance of the handle without disassembly of the handle;

Figure 5A is a horizontal cross-section taken through line 5A--5A of Figure 5 that shows the spring cap and the cable terminal inside the pole handle;

5 Figure 6 is a fragmentary vertical cross-section that shows another arrangement that permits adjustment without disassembly;

Figure 7 is a fragmentary vertical cross-section that shows an alternate method of attachment of the handle to large diameter, hollow shafts;

10 Figure 8 is a fragmentary vertical cross-section of an embodiment of the invention that utilizes a tension spring located in the shaft, with means for tension adjustment, without disassembly, located in the handle;

Figure 8A is a horizontal cross-section taken through line 8A--8A of Figure 8 that shows a hexagonal portion of the anchor member used to secure the upper end of the cable;

15 Figure 9 is a top plan view of the handle-base-engaging shaft base surface, showing the splines in the shaft base;

Figure 9A is a fragmentary vertical cross-section taken through line 9A--9A of Figure 9 that shows another view of the splines in the shaft base and a view of the ramp in the shaft base;

Figure 10 is a top plan view of the shaft-base-engaging handle base surface, showing the spline-receiving grooves in the handle base;

20 Figure 10A is a fragmentary vertical cross-section taken through line 10A--10A of Figure 10 that shows another view of a portion of the spline-receiving grooves in the handle base;

Figure 11 is a fragmentary vertical cross-section according to a preferred embodiment of the invention having a handle-to-shaft transition assembly that does not include splines and grooves;

Figure 12 is a top plan view of the handle-base-engaging shaft base surface according to the embodiment of the invention shown in Figure 11;

5 Figure 12A is a fragmentary vertical cross-section taken through line 12A--12A of Figure 12;

Figure 13 is a top plan view of the shaft-base-engaging handle base surface according to embodiment of the invention shown in Figures 11, 12, and 12A;

10 Figure 13A is a fragmentary vertical cross-section taken through line 13A--13A of Figure 13; and

Figure 14 is a graph showing articulation thumb force expressed as the percentage of the thumb force necessary to cause initial handle articulation as a function of the handle articulation angle.

Description of the Preferred Embodiment and Best Mode

15 Referring now specifically to the drawings, an athletic pole product according to a preferred embodiment of the invention is illustrated broadly at reference letter P in Figure 1. A conventional long, thin shaft 1 with a snow-penetrating tip 2 and a penetration limiting basket 3 is connected to a handle 4 comprising a handgrip 4A and a handle body 7. The connection is accomplished by a spring-loaded articulating joint 5. The articulating joint 5 provides a break-over feature that limits
20 the force that the ski pole P can apply to the hand, and is the subject of this invention.

A preferred design arrangement that accomplishes the desired objectives is shown in Figure 2, which is a cross-sectional view of the handle 4 of the safety ski pole P. Referring now to Figure

2, a compression spring 6 is utilized to provide a seating force between the handle body 7 and a matching seat comprising a shaft base 8, which is attached to the shaft 1. Coaxial centering of the handle 4 and the shaft 1 under normal loads imposed during skiing is accomplished by the matching surfaces and features of the handle body 7 and the seat 8, and a restraining rail comprising a rim 9
5 around the perimeter of the seat 8.

In the embodiment shown in Figure 2, the compression spring 6 resides in a guiding handle cavity 6A in the handle body 7 and its compressive force is transmitted from the handle body 7 to the seat 8 and the shaft 1 by attachment means comprising a flexible cable 10. The upper end of the cable 10 is anchored to a slidable spring cap 11 by means of a cross pin 12 inserted in a cross hole
10 13 in the spring cap 11. The cable 10 is secured at its lower end by a cross member 14 and a cable-end anchor 14A, the cross member 14 residing in the holes 14B in the shaft 1 and kept in place, in this instance, by a collar 15 of the seat 8. The cross member 14 extends beyond the outer diameter of the shaft 1 into axial slots 16 in the seat 8 in order to radially index the seat 8 to the shaft 1. Other means of retention may be used, such as that shown in Figure 3, which is particularly adaptable to
15 small diameter and/or solid shafts. In this instance, a cross pin 17A is held in place by a retaining ring 17. Other alternatives are to thread or cement the seat 8' to the shaft 1'.

Referring again to Figure 2, the level of transverse force that is required to be applied to the handle 4 to initiate the breakaway action is a function of the combination of the moment arm created by the radial dimension of a handle base 22 and the seating force provided by the spring 6 acting
20 through the flexible cable 10. A practical combination will have the diameter of the handle base 22 significantly larger than that of the shaft 1 and/or the handle body 7 where it interfaces with the handgrip 4A in order for a practical spring 6 to be able to reside within the dimensional confines of

the handle 4 or the shaft 1. Once the handle base 22 is selected, various means can be employed to provide the desired resistance to articulation by presetting the assembly compression of the spring 6. The means employed in the configuration shown in Figure 2 and Figure 2A is to assemble an anchor pin 12 into a selected pair of cross-holes 13, 13a, or 13b in the spring cap 11.

5 As shown in Figure 2, the handle body 7 is inserted into the handgrip 4A. The handgrip 4A, which is customarily a molded elastomer, is held in place by a button head screw 18 threaded into a cross member 19 which is inserted into the cross holes 20 in the handle body 7 and held in place by the handgrip 4A upon assembly. Referring again to both Figure 2 and Figure 2A, while the handgrip 4A can be held in place by friction or by an adhesive, it is convenient to be able to remove
10 it so that the user may adjust the handle tension by selecting a different pair of cross holes 13, 13a, or 13b in the spring cap 11 in which to insert anchor pin 12.

 When the spring tension is adjusted properly, the handle 4 and the shaft 1 will maintain a coaxial position under normal bending moments imposed by the skier's hand, wrist, and arm, as reacted by the shaft 1 against normally encountered surfaces. However, if a higher than normal
15 bending moment is experienced, for instance as the result of a fall that may trap the pole P under the skier's body or under his ski(s), as shown in Figure 4, the handle 4 will pivot with an edge 21 of the handle base 22 forming the fulcrum, and a handle-base-engaging surface 24 between the rail 9 and a central alignment post 23 of the seat 8 forming the pivot point. When the handle 4 moves to a large articulation angle, the handle base 22 slides across the handle-base-engaging surface 24 of the
20 seat 8, coming to rest against the post 23 of the seat 8, where it remains as the handle 4 articulates further. The handle base 22 is prevented from moving further toward the center of the seat 8 by the combined restraining action of the post 23 and the cable 10 as the handle 4 is articulated to extreme

angles, even beyond 90 degrees. The flared holes 25A in the handle body 7 and the seat 8 through which the cable 10 passes are suitably radiused to prevent excessive bending stresses in the cable 10, and the small diameter of the holes 25A fit closely to the cable 10 to prevent snow from entering the handle cavity 6A or a shaft cavity 1A. The spring 6 will be extended beyond the initial
5 adjustment extension as a result of the handle articulation, but the resulting load on the skier's hand, thumb and wrist will not be sufficient to cause injury. Once the handle base 22 rests against the post 23, the articulating force significantly reduces, becoming much less than the initiating force, as a result of a reduction in the moment arm as the edge 21 of the handle base 22 moves toward the post 23.

10 When the bending moment on the handle 4 is released, it will automatically resume its normal position coaxial with the shaft 1.

The post 23 of the seat 8 is splined, fitting loosely but non-rotatably into a similarly splined pocket 25B in the base of the handle body 7. Spline grooves 25 in the handle body 7 extend axially from the upper end of the pocket 25B, then bend around the lower end of the pocket 25B, extending
15 radially to the outer diameter of the handle base 22. As the handle 4 is articulated relative to the shaft 1, one or more of the splines on the post 23 will engage matching spline grooves 25 of the handle base 22 throughout the range of articulation of the handle 4, thereby resisting rotation of one relative to the other. This feature resists misindexing of the handle 4 and the shaft 1, each of which may have non-symmetrical features that require alignment. Additionally, this prevents twisting of
20 the flexible cable 10 that otherwise may result from repeated actuations. Another embodiment of the invention with additional features to restrict rotation of the handle relative to the shaft is described below relative to Figures 9, 9A, 10, and 10A.

Figure 5 and Figure 5A show an alternative arrangement for providing spring compression adjustment. The flexible cable 26 has an internally threaded terminal 27 attached to its upper end. This terminal 27 has a hexagonal exterior surface 27A to prevent its rotation in a hexagonal hole 27B in the spring cap 28 while permitting axial relative translation as determined by the position of an adjusting screw 29, accessed through a hole 30. In this embodiment, the compression spring 31 does not have squared and ground ends and the spring seats in the spring cap 28 and the handle body 32 are configured to fit the plain cut coil ends 26A of the spring 31. This causes the adjusting torque to be transmitted from the screw 29 to the cable terminal 27 through the hexagonal hole 27B in the spring cap 28 through the spring 31 to the handle body 32, thereby preventing twisting of the cable 26 during adjustment. For illustrative purposes, the spring 31 is shown compressed to the maximum allowable initial force setting.

Figure 6 shows still another method of providing adjustability of spring compression. The flexible cable 33 has an externally threaded terminal 34 attached to its upper end and extending through the spring cap 35, which is retained by an adjusting nut 36. Adjustment of the position of the nut 36 without twisting the cable 33 is accomplished by holding the terminal 34 with a screwdriver while turning the nut 36. Access to the terminal 34 and the nut 36 is provided by removal of a spring-clip retained cover 37.

Figure 7 shows an alternate method of joining the handle 4' to the shaft 40. The seat 38 includes a cylindrical projection 39 that pilots inside the shaft 40, with the upper end of the shaft 40 seating on the underside of the seat 38. The flexible cable 41 is anchored at the lower end by a cross member 42 residing in a pair of transverse holes 42A in the shaft 40. The seat 38 and the shaft 40 are kept in close contact by the tension in the cable 41. The cross member 42 is suitably retained

transversely; in this embodiment, this is achieved by a sheath 43 held in place by an elastomeric sleeve 44.

While the examples shown in Figures 2 through 7 have employed a compression spring located in the ski pole handle, the objective of this invention can be achieved through other combination of spring types and locations, for instance: a tension spring located in the handle; a compression spring located in the shaft; or a tension spring located in the shaft. Additionally, compound springs may be used. An example of an alternate spring arrangement is shown in Figure 8. Referring to Figure 8, a tension spring 45 is utilized to provide a seating force between the handle body 46 of the handle 4" and the matching seat 47, which is attached to the shaft 48. A tension spring 45 is anchored at its lower end by a pin 49, which resides in holes 49A in the shaft 48 and is kept in place by, in this instance, a sleeve 50. Other means of retention may be used. The spring force is transferred to the handle 4" through the flexible cable 51, which is attached to an anchor member 52 by means of a second pin 53. As shown in Figure 8 and Figure 8A, the anchor member 52 is kept from rotating relative to the handle 4" by a hexagonal portion 54 of the anchor member 52 that is axially slidable through a matching hexagonal cavity 54A in the handle body 46. The axial position of the anchor member 52 is moveable, to permit adjustment of the spring tension through use of a screw 55 threaded into the anchor member 52. The head of the screw 55 is seated on a second anchor member 56, which in turn rests centrally on the handle body 46.

In a preferred embodiment of the ski pole shown in Figures 9, 9A, 10, and 10A, the seat 8" and handle base 22' include a system of splines and spline-receiving grooves for minimizing potential rotation of the handle body 7' relative to the shaft (Figures 1 through 8) both when the handle body 7' is unarticulated and in all phases of handle articulation. Turning to Figures 9 and 9A,

the seat 8" is shown. A plurality of radial splines 60 are formed with a handle-base-engaging surface 24' of the seat 8". In addition, a plurality of axial splines 61 are formed with the alignment post 23 and the radial splines 60. The radial splines 60 and the axial splines 61 engage spline-receiving grooves in the handle base (Figures 10 and 10A) during handle articulation in order to minimize rotational motion of the handle body (Figure 10A) and the shaft (Figures 1 through 8) during handle articulation. Other features of the seat 8" serve to stabilize the handle body (Figure 10A) when it is unarticulated and during articulation. Specifically, a narrow circumferential annulus 62 is provided in the seat 8" for the handle base (Figures 10 and 10A) to seat upon during normal, unarticulated operation. In addition, in one embodiment of the seat 8", a ramp 63 is also provided to facilitate movement of the handle base (Figures 10 and 10A) onto the annulus 62 following articulation.

Turning now to Figures 10 and 10A, the handle base 22' of the handle body 7' is shown. A shaft-base-engaging surface 64 on the handle base 22' features spline grooves 25 for receiving the radial splines and axial splines of the shaft base (Figures 9 and 9A) during handle articulation. The spline grooves 25 each have a radial portion 70, a radial-to-axial transition portion 71, and an axial portion 72. In addition, axial extensions 65 of the radial portions 70 of the spline grooves 25 are formed in the outer periphery of the handle base 22'. The axial extensions 65 further guide and stabilize the handle body 7' as the handle base 22' engages the shaft base (Figures 9 and 9A) during handle articulation. The shaft-base-engaging surface 64 of the handle base 22' also provides spline groove pairs 66 that are parallel to and flank the radial portions 70 of the spline grooves 25. The spline groove pairs 66 serve to engage the two axial splines formed with the alignment post on the shaft base (Figures 9 and 9A) that flank any particular axial spline engaged by the corresponding radial portion 70 of a spline groove 25 on the handle base 22' during a specific handle articulation.

Like the radial portions 70 of the spline grooves 25, the radial-to-axial transition portions 71 of the spline grooves, the axial portions 72 of the spline grooves, and the axial extensions 65 of the radial portions 70 of the spline grooves 25, the spline groove pairs 66 are provided to guide and stabilize the handle body 7' as the handle base 22' engages the shaft base (Figures 9 and 9A) during handle articulation, thereby minimizing rotational motion of the handle body 7' relative to the shaft (Figures 1 through 8) during handle articulation.

The splines and grooves discussed above provide anti-rotational advantages to one preferred embodiment of the athletic pole; the basic advantages provided by the enlarged handle-to-shaft transition assembly exist regardless of the presence or absence of the splines and grooves. Turning to Figure 11, a preferred embodiment of the invention without splines and grooves is shown. The enlarged dimension of the handle base 80 relative to the handle body 81, and the correspondingly enlarged dimension of the seat 82 relative to the shaft 83, ease handle articulation by providing advantages resulting from, among other things, the moving fulcrum formed by the handle base 80 and the seat 82 during handle articulation.

One advantage provided by the enlarged dimensions of the handle base 80 and the seat 82 and the moving fulcrum they form during handle articulation is illustrated in the graph shown in Figure 14 relative to a preferred embodiment of the invention. The "100 percent" marking on the vertical scale of the graph in Figure 14 represents the pressure required for the thumb to initiate handle articulation when applying force at a point on the handle 92 without assistance from the remainder of the hand, thereby representing a worst-case accident scenario. In general, after an abbreviated initial range of handle articulation, the enlarged dimensions of the handle base 80 and the seat 82 provide for the force necessary for the user either to continue articulating the handle 92

or to maintain the handle 92 in a desired articulated position to be reduced relative to the bending force that would prevail if the edge 85 of the handle base 80 were not allowed to travel across the handle-base-engaging surface 91 toward the center of the seat 82. The curve in Figure 14 illustrates that, in a preferred embodiment of the invention, after the initial range of articulation, the thumb force necessary to articulate the handle 92 or to maintain the handle 92 in a desired articulated position actually remains less than the thumb force necessary to initiate handle articulation. When considered in a structural context, as illustrated by Figures 11 and 14, the enlarged dimensions of the handle base 80 and seat 82 and the associated moving fulcrum provide for the edge 85 of the handle base 80 to travel across the handle-base-engaging surface 91 of the seat 82 from the rail 86 to the alignment post 90 and for the handle 92 to continue to be further articulated after the edge 85 of the handle base 80 engages the alignment post 90 such that, after the initial range of handle articulation, the force necessary for the user either to continue articulating the handle 92 or to maintain the handle 92 in a desired articulated position is reduced relative to the bending force that would prevail if the edge 85 of the handle base 80 were not allowed to travel across the handle-base-engaging surface 91 toward the center of the seat 82; in a preferred embodiment, as shown in Figure 14, such force actually remains less than the bending force necessary to articulate the handle 92 through the initial range of handle articulation. In addition, the enlarged dimensions of the handle base 80 and the seat 82 and the resultant moving fulcrum reduce the stresses on the spring 84 and the cable 93 relative to poles having no enlarged break-over features or moving fulcrum.

The above-described reduction in the force required to continue or maintain handle articulation after the initial range of handle articulation enhances user safety by reducing the amount of thumb, hand, and wrist stress experienced during handle articulation, thereby creating a shock-

absorbing effect and reducing the chance or degree of injury in the event of an accident. In addition, the reduction in spring and cable stress relative to poles having no enlarged break-over features or moving fulcrum minimizes spring, cable, and handle body and shaft-base-engaging surface wear resulting from articulation and, as a result, lengthens the life of the unit.

5 As stated above, the splines and grooves found in other preferred embodiments of the invention have no effect on these advantages of this preferred embodiment of the invention, functioning instead to minimize the rotation of the handle 92 relative to the shaft 83. In addition, despite the above-described roles of the alignment post 90 and the rail 86 in handle articulation as it occurs in one embodiment of the invention, neither the alignment post 90 nor the rail 86 are
10 necessary for the advantages of the enlarged dimensions of the handle base 80 and seat 82 to be present.

 For the sake of clarity and completeness, Figures 12 and 12A are provided to illustrate the seat 82 without splines or grooves, and Figures 13 and 13A are provided to illustrate the handle base 80 without splines or grooves, all according to the preferred embodiment of the invention shown in
15 Figure 11.

 A safety athletic pole is described above. Various details of the invention may be changed without departing from its scope. Furthermore, the foregoing description of the preferred embodiment of the invention and the best mode for practicing the invention are provided for the purpose of illustration only and not for the purpose of limitation--the invention being defined by the
20 claims.

Amended page 19

We claim:

1. An athletic pole including a handle, a shaft, and a handle-to-shaft transition assembly, said transition assembly adapted for allowing the handle to articulate relative to the shaft, said transition assembly comprising:

(a) said handle including a radially enlarged handle base;

(b) said shaft including a main shaft portion and a radially enlarged shaft base on said main shaft portion, said shaft base comprising a collar for receiving the main shaft portion and an enlarged handle base support formed with said collar;

(c) a first engaging surface defined by one of the enlarged handle base support and the handle base correspondingly sized to a second engaging surface defined by the other of the handle base support and the handle base for permitting mating engagement of the first engaging surface and the second engaging surface;

(d) wherein the peripheral dimension of said handle base and the peripheral dimension of said handle base support are each at least twice the peripheral dimension of the main shaft portion and at least twice the peripheral dimension of the handgrip engaging portion; and

Amended page 20

(e) a raised alignment post defining an inner boundary of the first engaging surface and a pocket on the second engaging surface;

(f) an annular rim extending around the periphery of the first engaging surface

(g) wherein said pocket receives said alignment post when the handle is not articulated and said alignment post and said rim limits the movement of the second engaging surface across the first engaging surface during handle articulation by forming an inner boundary and an outer boundary, respectively, of the first engaging surface; and

(h) said handle base and said shaft base being biased together by a tension force into a mating, coaxially aligned position when any bending forces applied to the pole are insufficient to overcome the tension force, the handle being pivotable to an articulated position relative to the shaft upon the application of a predetermined bending force on the pole sufficient to overcome the tension force;

whereby, during handle articulation, an outer periphery of the second engaging surface travels across and engages the first engaging surface such that, after an initial range of handle articulation, the bending force necessary to continue articulation or to maintain the handle in a desired articulated position relative to the shaft is less than the bending force necessary to articulate the handle through the initial range of handle articulation.

2. Any athletic pole adapted for minimizing injuries to the hand and wrist of the user

Amended page 21

in the event of an accident, said athletic pole comprising:

(a) a handle including a radially enlarged handle base;

(b) a shaft extending from the handle and including a main shaft portion and a radially enlarged shaft base on said main shaft portion, said shaft base comprising a collar for receiving the main shaft portion and an enlarged handle base support formed with said collar

(c) a first engaging surface defined by one of the shaft base and the handle base and correspondingly sized to a second engaging surface defined by the other of the shaft base and the handle base for permitting mating engagement of the first engaging surface and the second engaging surface;

(d) wherein the peripheral dimension of said handle base and the peripheral dimension of said handle base support are each at least twice the peripheral dimension of the main shaft portion and at least twice the peripheral dimension of the handgrip-engaging portion;

(e) attachment means for attaching the handle to the shaft; and

(f) biasing means exerting sufficient tension on said attachment means for biasing said attachment means to maintain the handle base and the shaft base in a mating,

Amended page 22

coaxially aligned position when any bending forces applied to the pole are insufficient to overcome the tension of the biasing means on the attachment means, the periphery of the second engaging surface and the first engaging surface forming a movable fulcrum point thereon for permitting controlled, tensioned articulation of the handle relative to the shaft resulting from an application of a predetermined bending force on the pole sufficient to overcome the tension of the biasing means on the attachment means for pivoting the handle to an articulated position relative to the shaft;

whereby, during handle articulation, an outer periphery of the second engaging surface travels across and engages the first engaging surface such that, after an initial range of handle articulation, the bending force necessary to continue articulation or to maintain the handle in a desired articulated position relative to the shaft is less than the bending force necessary to articulate the handle through the initial range of handle articulation.

3. An athletic pole according to claim 2, a raised alignment post defining an inner boundary of the first engaging surface and a pocket on the second engaging surface, said pocket receiving said alignment post when the handle is not articulated, and the inner boundary of the alignment post limiting movement of the second engaging surface relative to the first engaging surface during handle articulation.
4. An athletic pole according to claim 3, wherein the alignment post is annular.
5. An athletic pole according to claim 2, wherein the first engaging surface includes

Amended page 23

a rim that, during handle articulation, limits the movement of the periphery of the second engaging surface across the first engaging surface by forming an outer boundary of the first engaging surface, and, upon release of the handle, assists the handle in resuming a coaxially aligned position relative to the shaft.

6. An athletic pole according to claim 5, wherein the rim is annular and extends around the periphery of the first engaging surface.

7. An athletic pole according to claim 2, wherein the attachment means is a cable and the biasing means is a spring.

8. An athletic pole adapted for minimizing injuries to the hand and wrist of the user in the event of an accident, said athletic pole comprising:

(a) a handle including a radially enlarged handle base;

(b) a shaft extending from the handle and including a main shaft portion and a radially enlarged shaft base on said main shaft portion, said shaft base comprising a collar for receiving the main shaft portion and an enlarged handle base support formed with said collar;

(c) a first engaging surface defined by one of the handle base support and the handle base sized to a second engaging surface defined by the other of the handle base

Amended page 24

support and the handle base for permitting mating engagement of the first engaging surface and the second engaging surface,

(d) an annular raised alignment post on the first engaging surface and an annular rim extending around the periphery of the first engaging surface, said alignment post received by a pocket on said second engaging surface while the handle is not articulated and said alignment post and said rim limiting the movement of the periphery of the second engaging surface across the first engaging surface during handle articulation by forming an inner boundary and an outer boundary, respectively, of the first engaging surface, and wherein said rim also assists the handle in resuming a coaxially aligned position relative to the shaft upon release of the handle;

(e) wherein the peripheral dimension of said handle base and the peripheral dimension of said handle base support are each at least twice the peripheral dimension of the main shaft portion and at least twice the peripheral dimension of the handle;

(f) a cable extending through a centrally located opening of the alignment post for attaching the handle to the shaft; and

(g) a spring for exerting sufficient tension on said cable for biasing said cable to maintain the handle base and the shaft base in a mating, coaxially aligned position when any bending forces applied to the pole are insufficient to overcome the tension of the spring on the cable, the periphery of the second engaging surface and the first engaging

Amended page 25

surface collectively forming a movable fulcrum point thereon for permitting controlled, tensioned articulation of the handle relative to the shaft resulting from an application of a predetermined bending force on the pole sufficient to overcome the tension of the spring on the cable for pivoting the handle to an articulated position relative to the shaft;

whereby, during handle articulation, the outer periphery of the second engaging surface travels across and engages the first engaging surface such that, after an initial range of handle articulation, the bending force necessary to continue articulation or to maintain the handle in a desired articulated position relative to the shaft is less than the bending force necessary to articulate the handle through the initial range of handle articulation.

9. An athletic pole adapted for minimizing injuries to the hand and wrist of the user in the event of an accident, said athletic pole comprising:

(a) a handle having a handle base;

(b) a shaft extending from the handle and including a proximal end adjacent the handle, a distal end, and a shaft base on the proximal end that normally engages the handle base;

(c) attachment means for attaching the handle base to the shaft base;

Amended page 26

(d) a first engaging surface, defined by one of the shaft base and the handle base, sized to a second engaging surface, defined by the other of the shaft base, and the handle base for permitting mating engagement of the first engaging surface and the second engaging surface;

(e) biasing means exerting sufficient tension on said attachment means for biasing said attachment means to maintain the handle base; and the shaft base in a mating, coaxial position during normal use, the periphery of the second engaging surface and the first engaging surface collectively forming a movable fulcrum point thereon for permitting controlled, tensioned articulation of the handle relative to the shaft resulting from an application of a predetermined bending force on the pole sufficient to overcome the tension of the biasing means on the attachment means; and

(f) a raised alignment post defining an inner boundary on the first engaging surface and a pocket on the second engaging surface, said pocket receiving said alignment post when the handle is not articulated, and the inner boundary of the alignment post limiting movement of the second engaging surface relative to the first engaging surface during handle articulation.

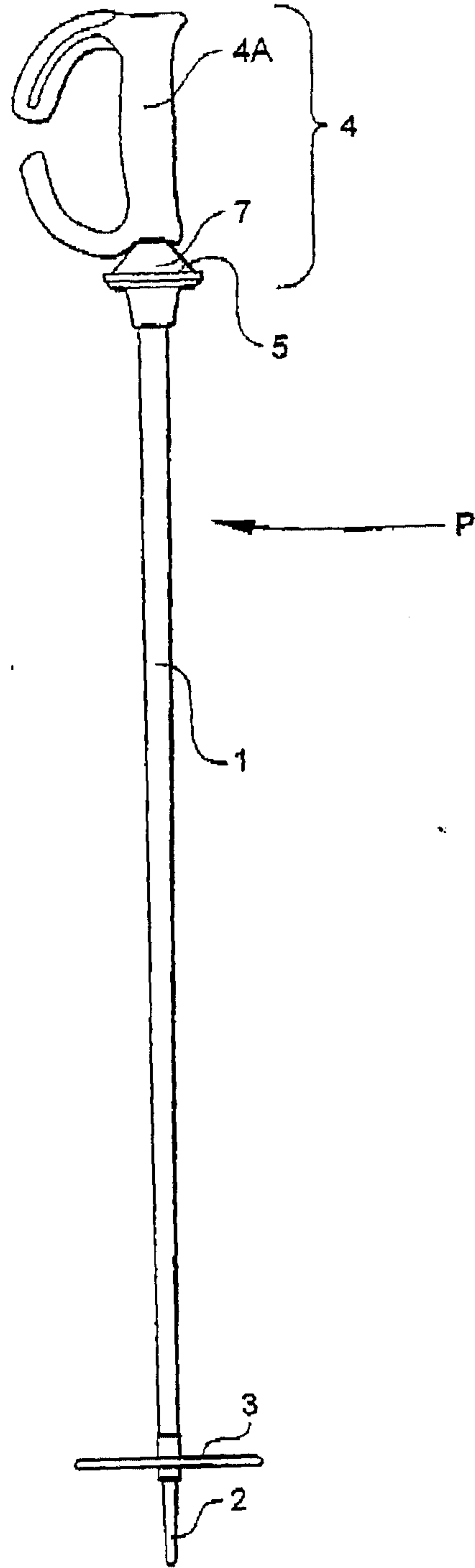

Fig. 1

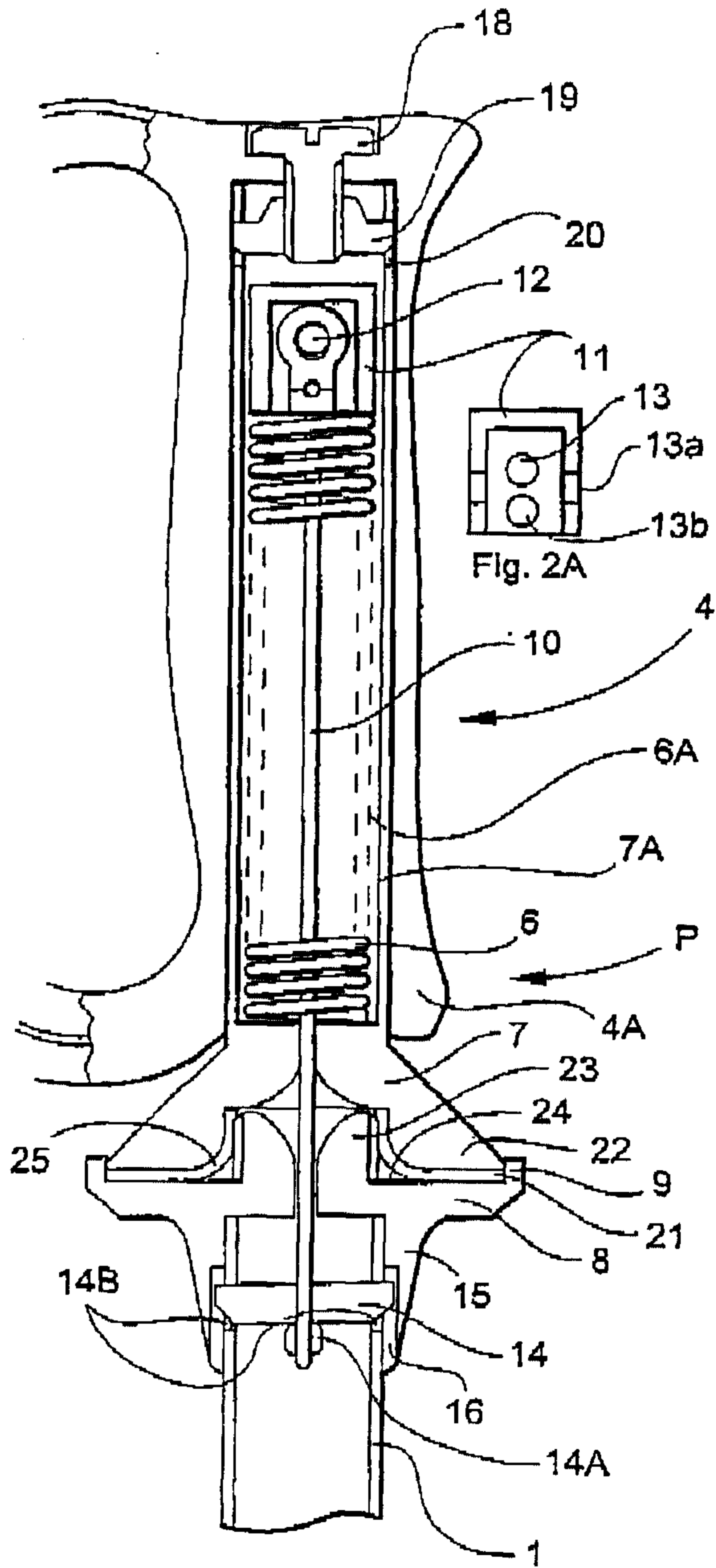

Fig. 2

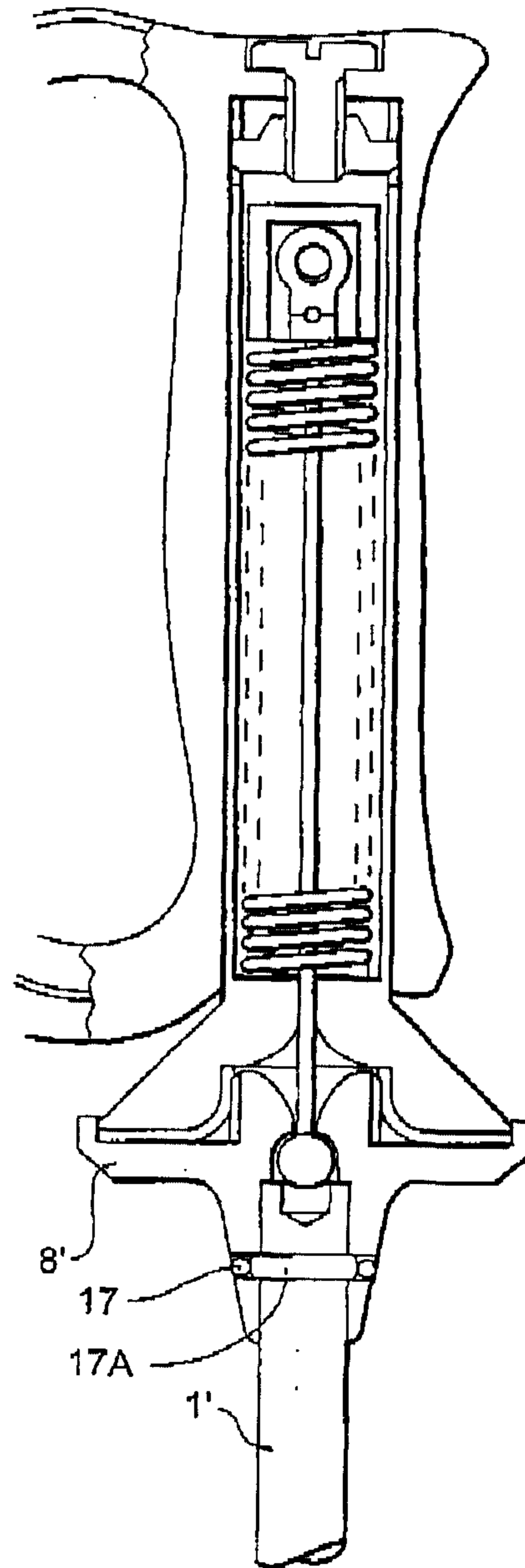

Fig. 3

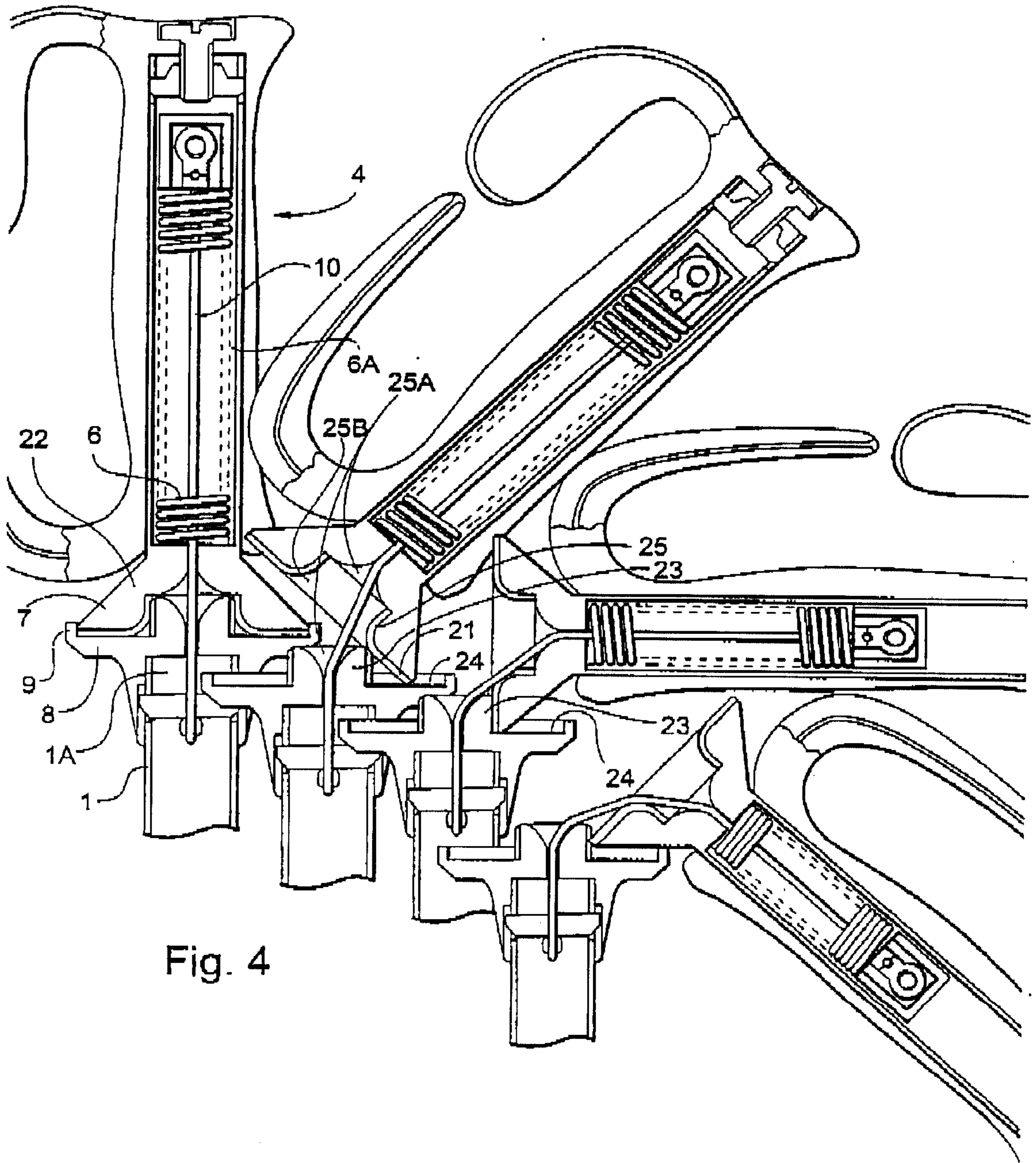

Fig. 4

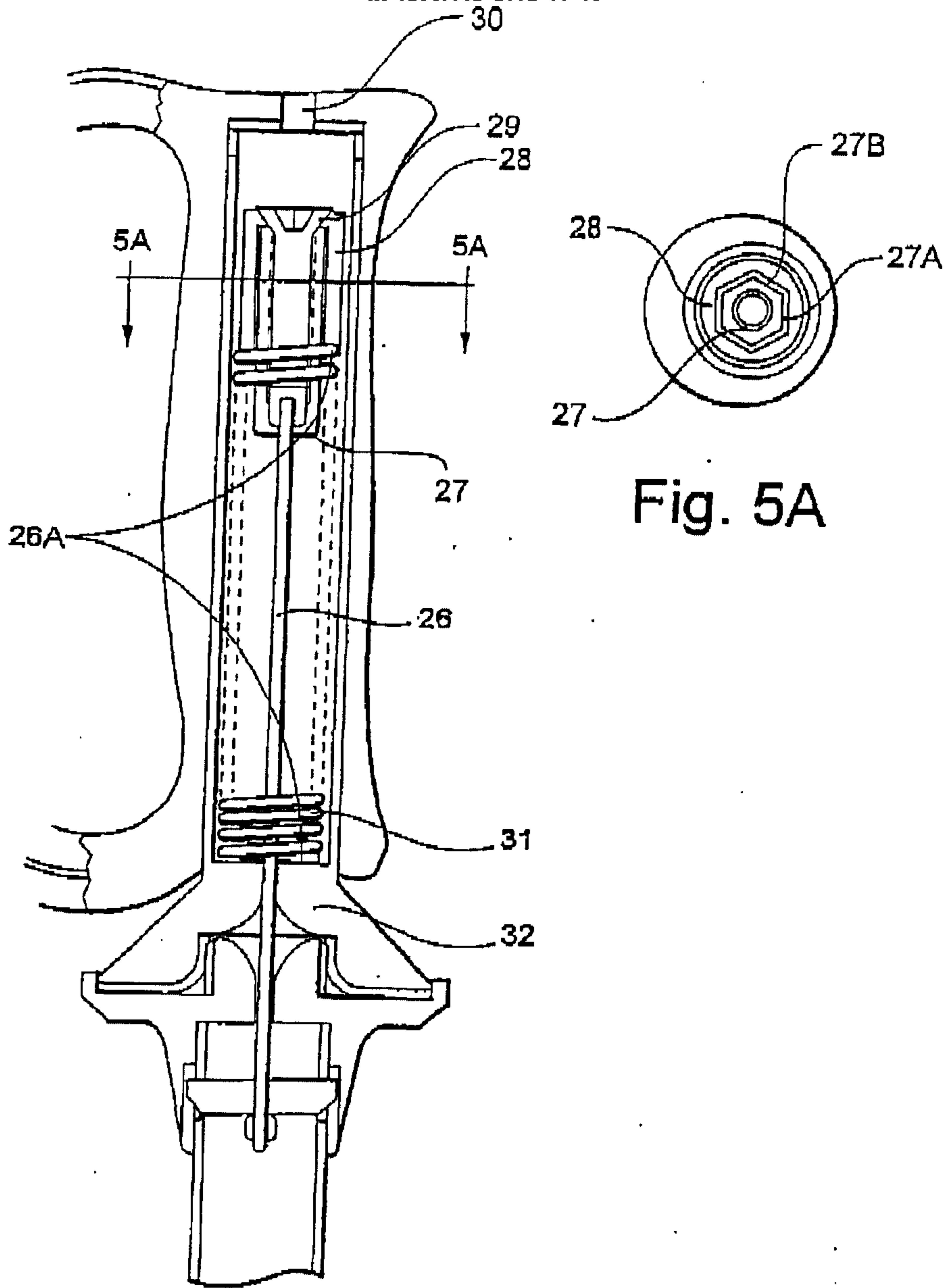

Fig. 5A

Fig. 5

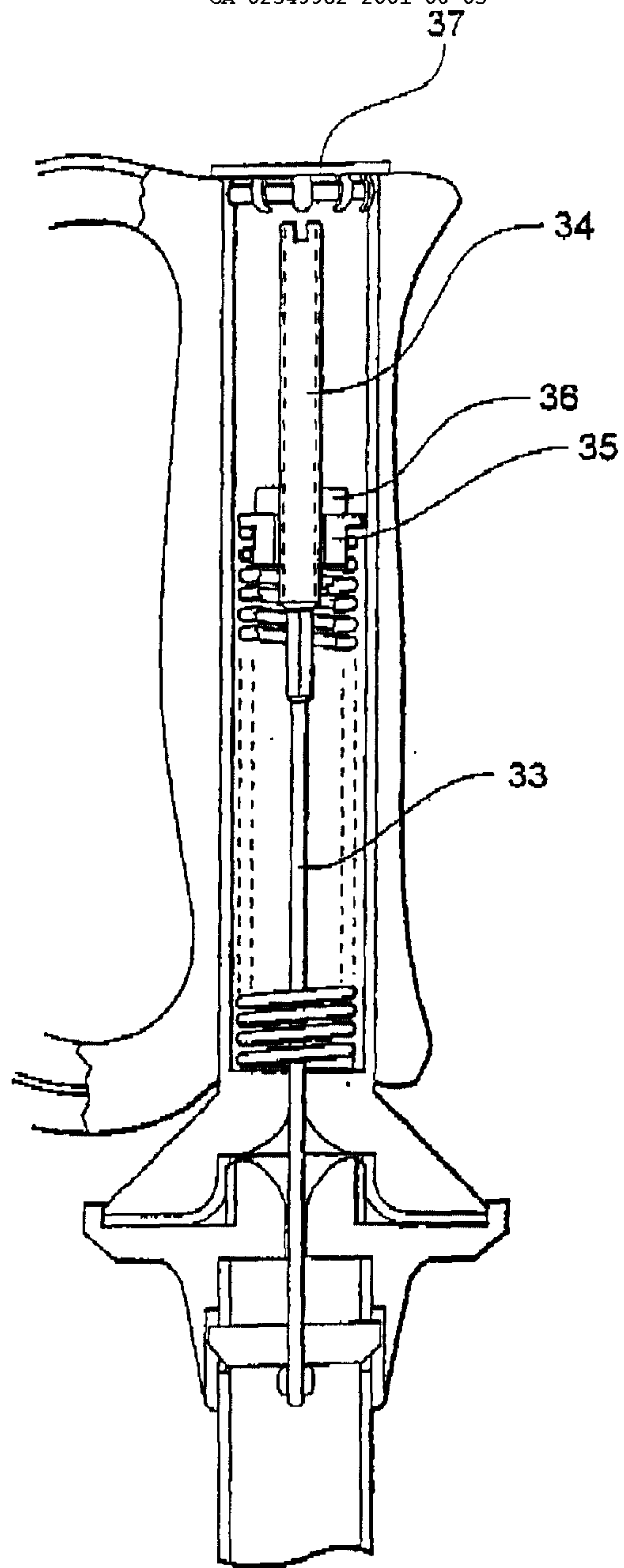

Fig. 6

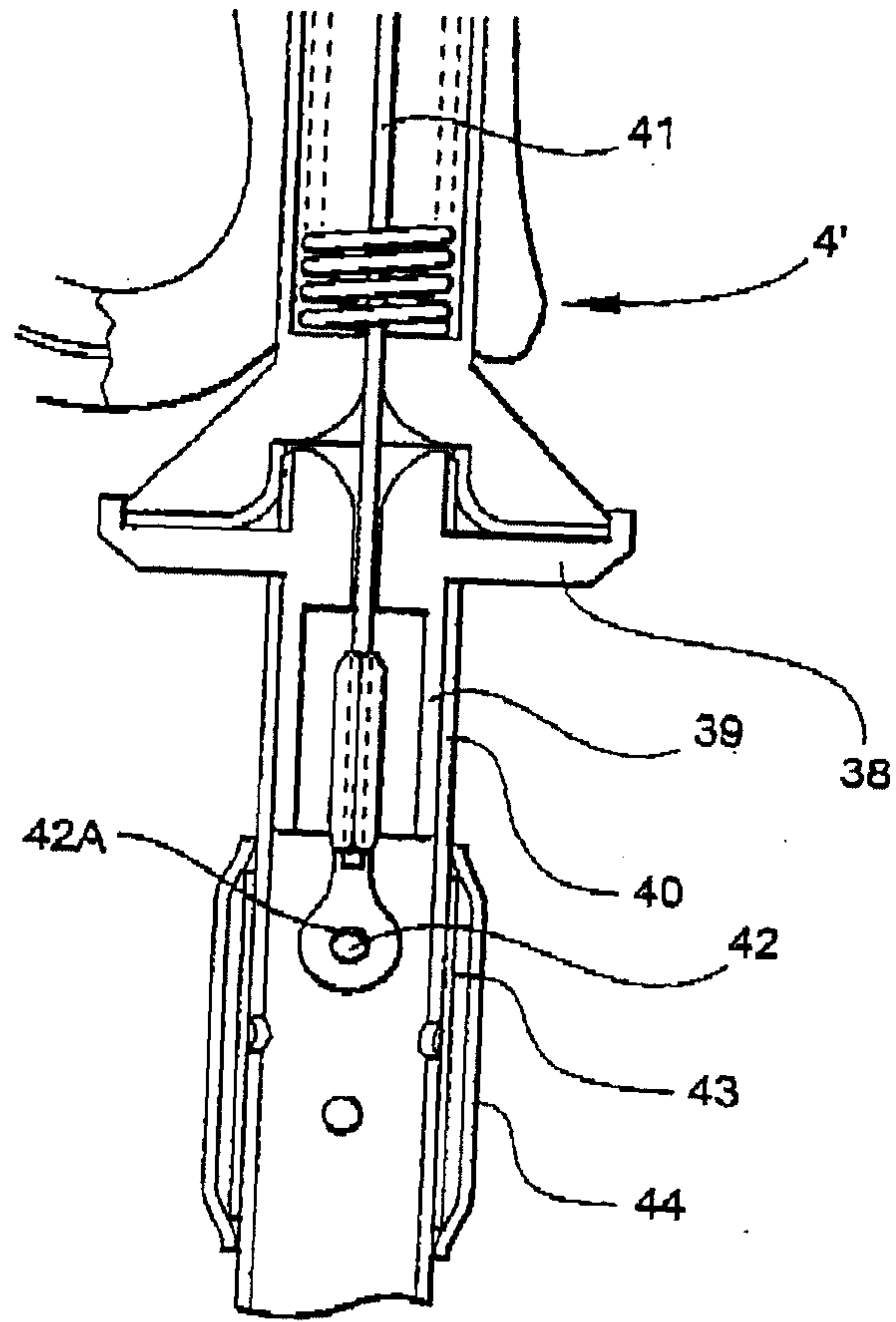

Fig. 7

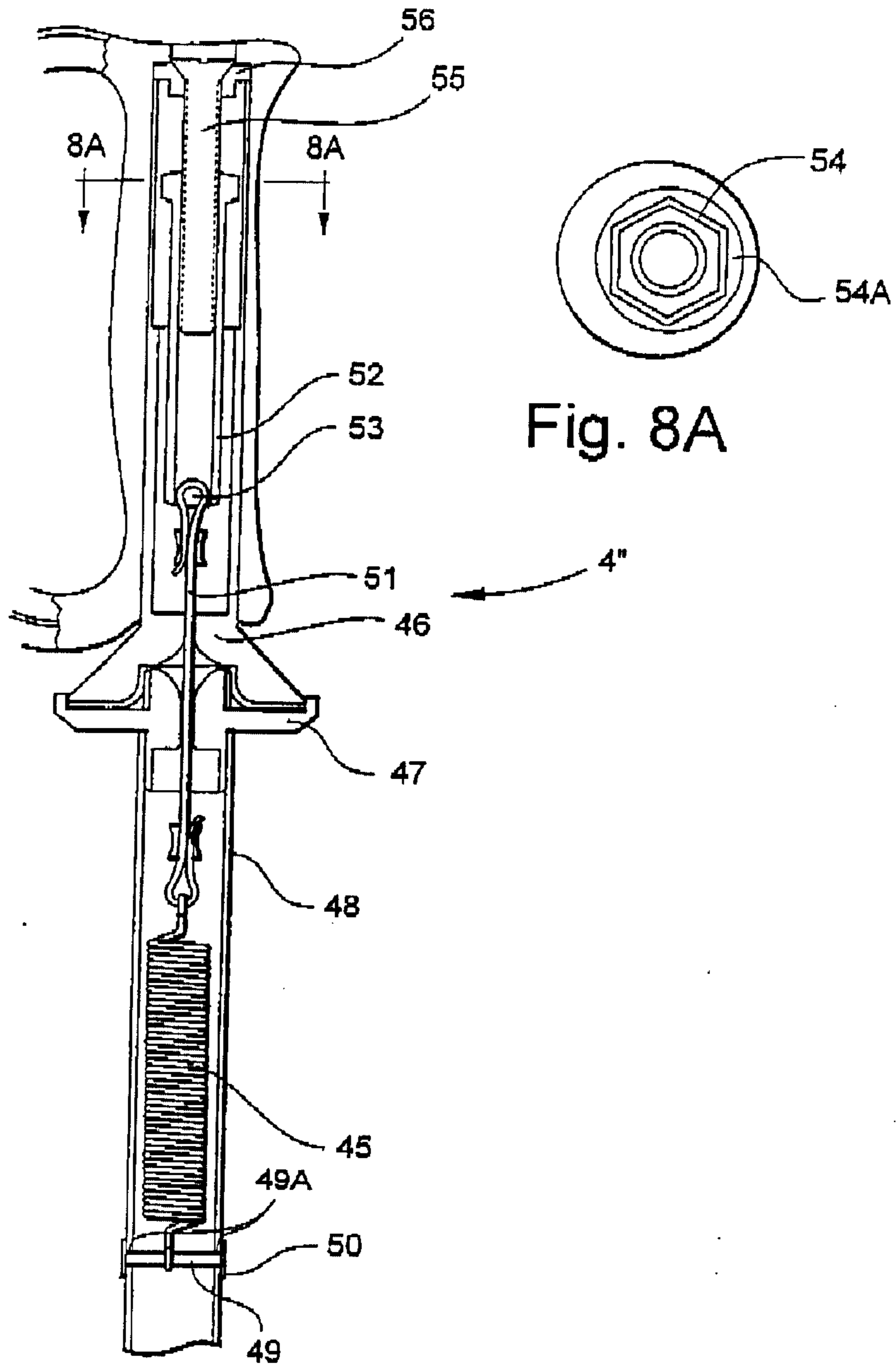

Fig. 8

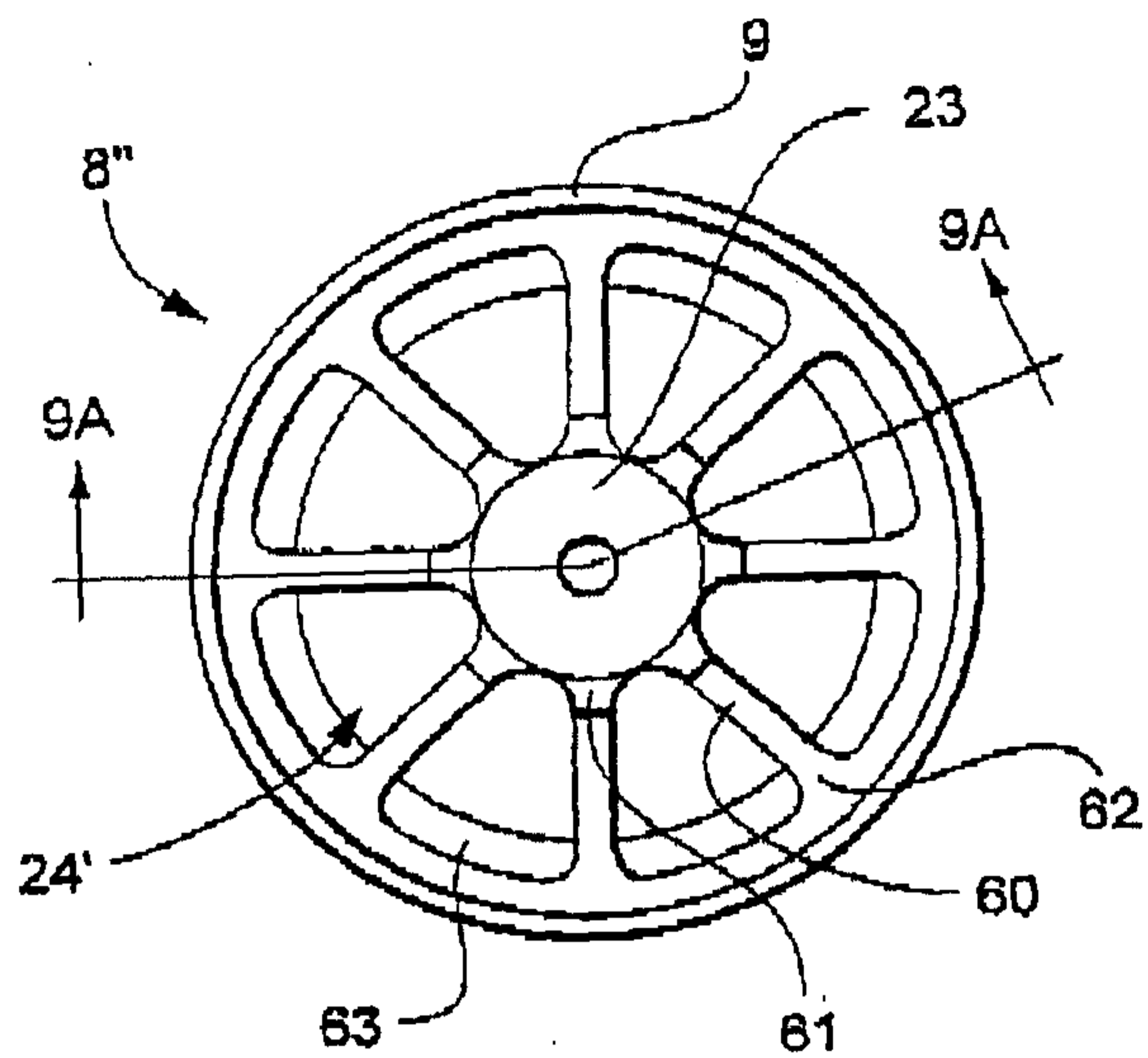
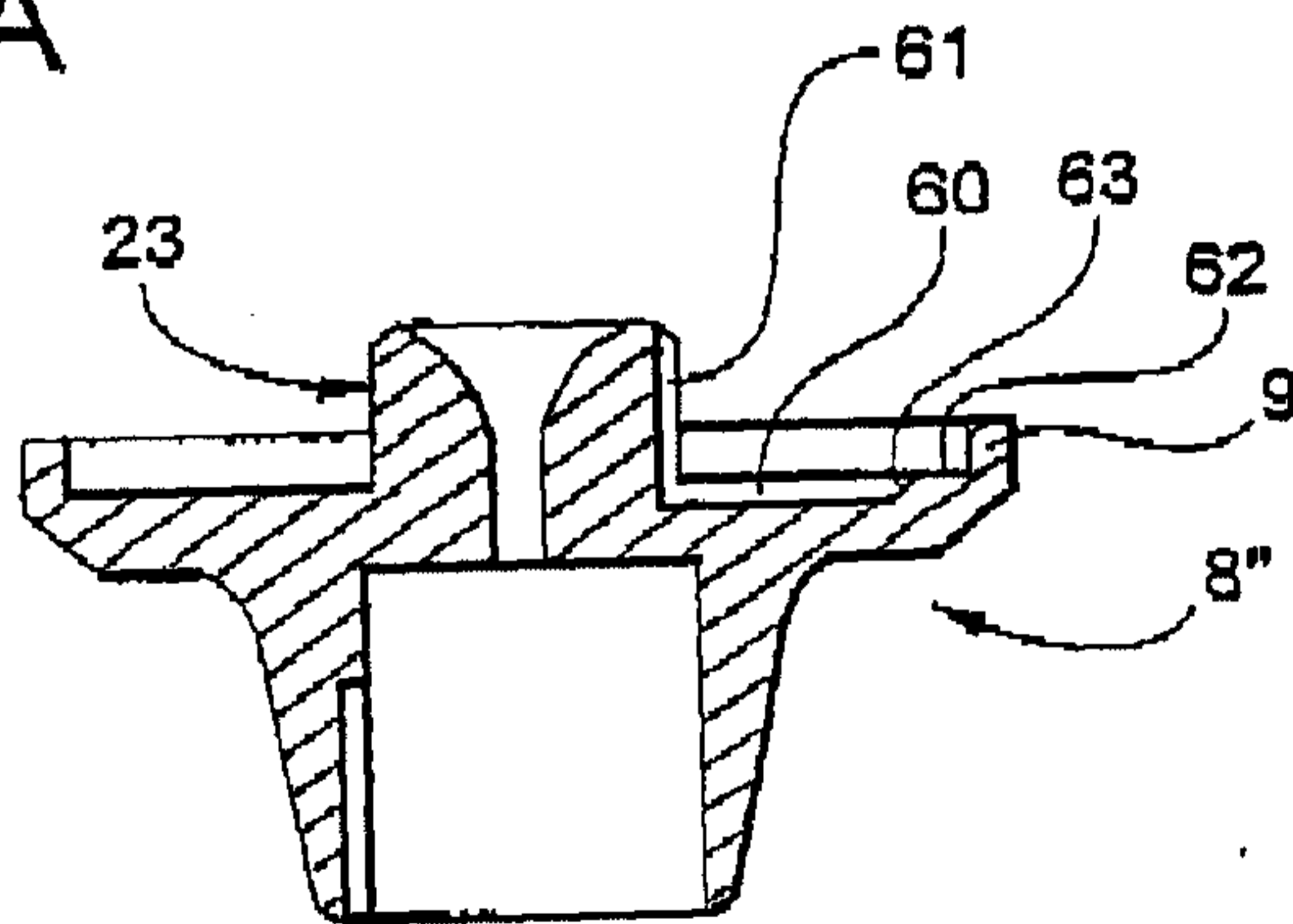
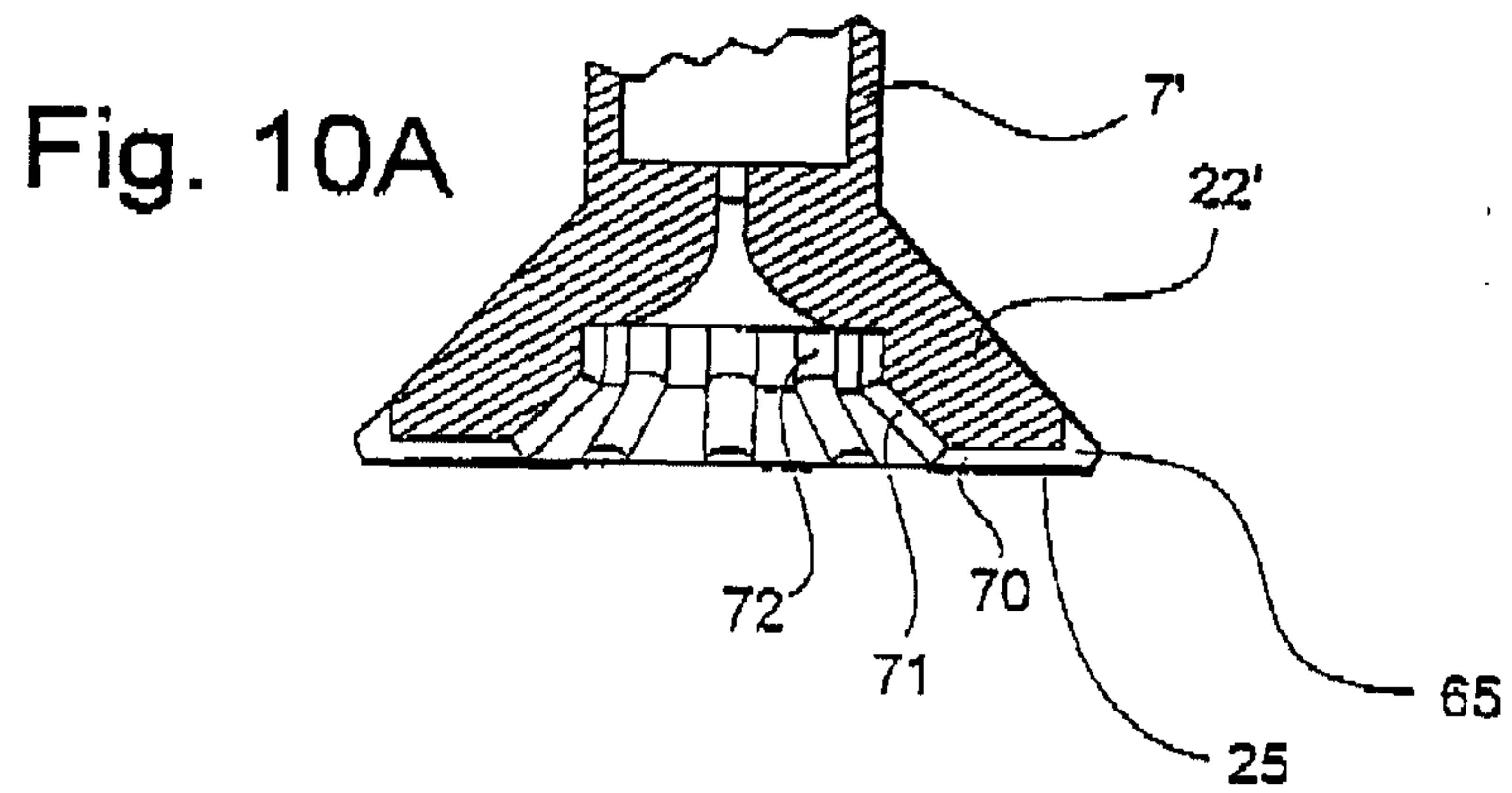
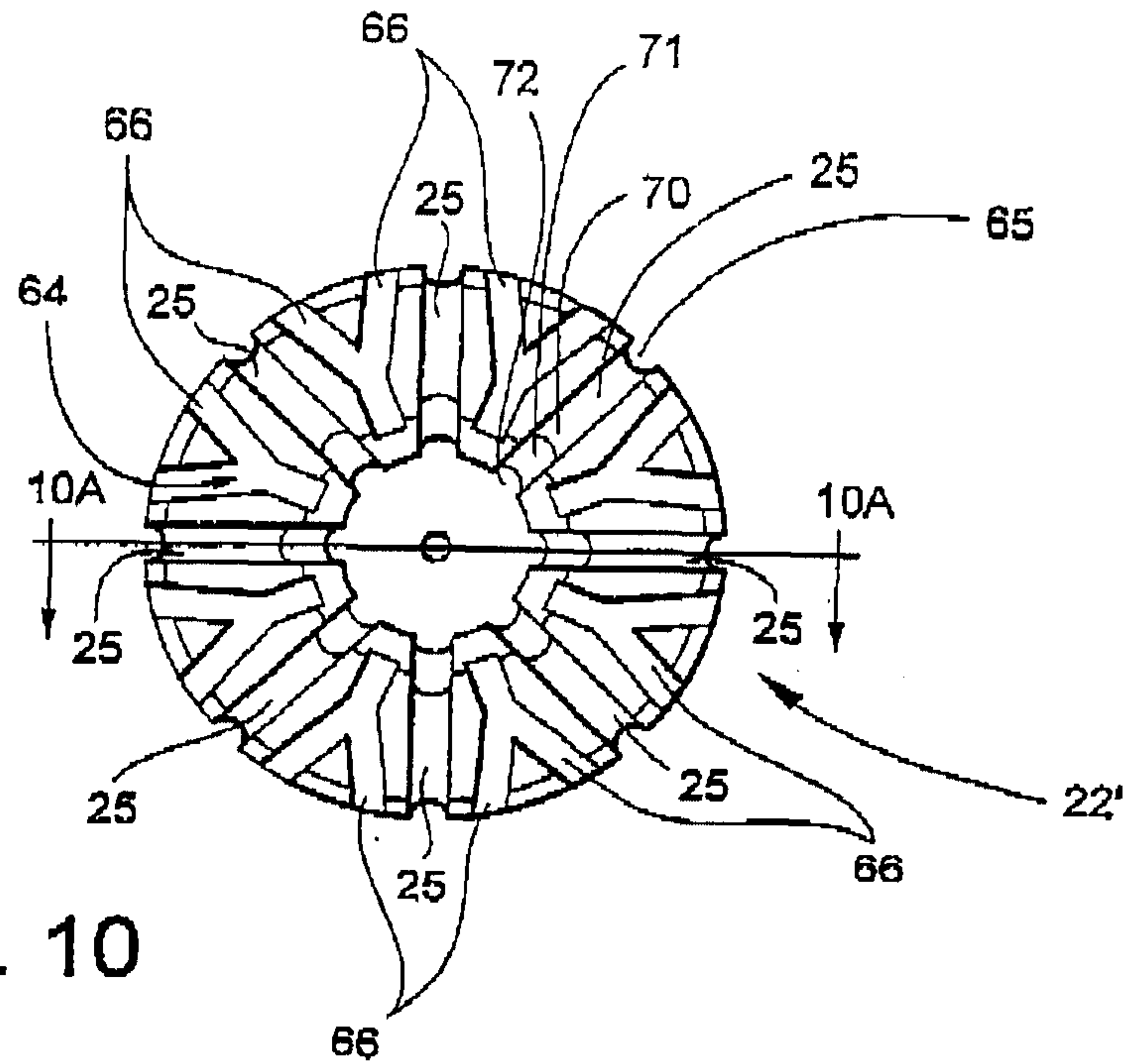

Fig. 9

Fig. 9A





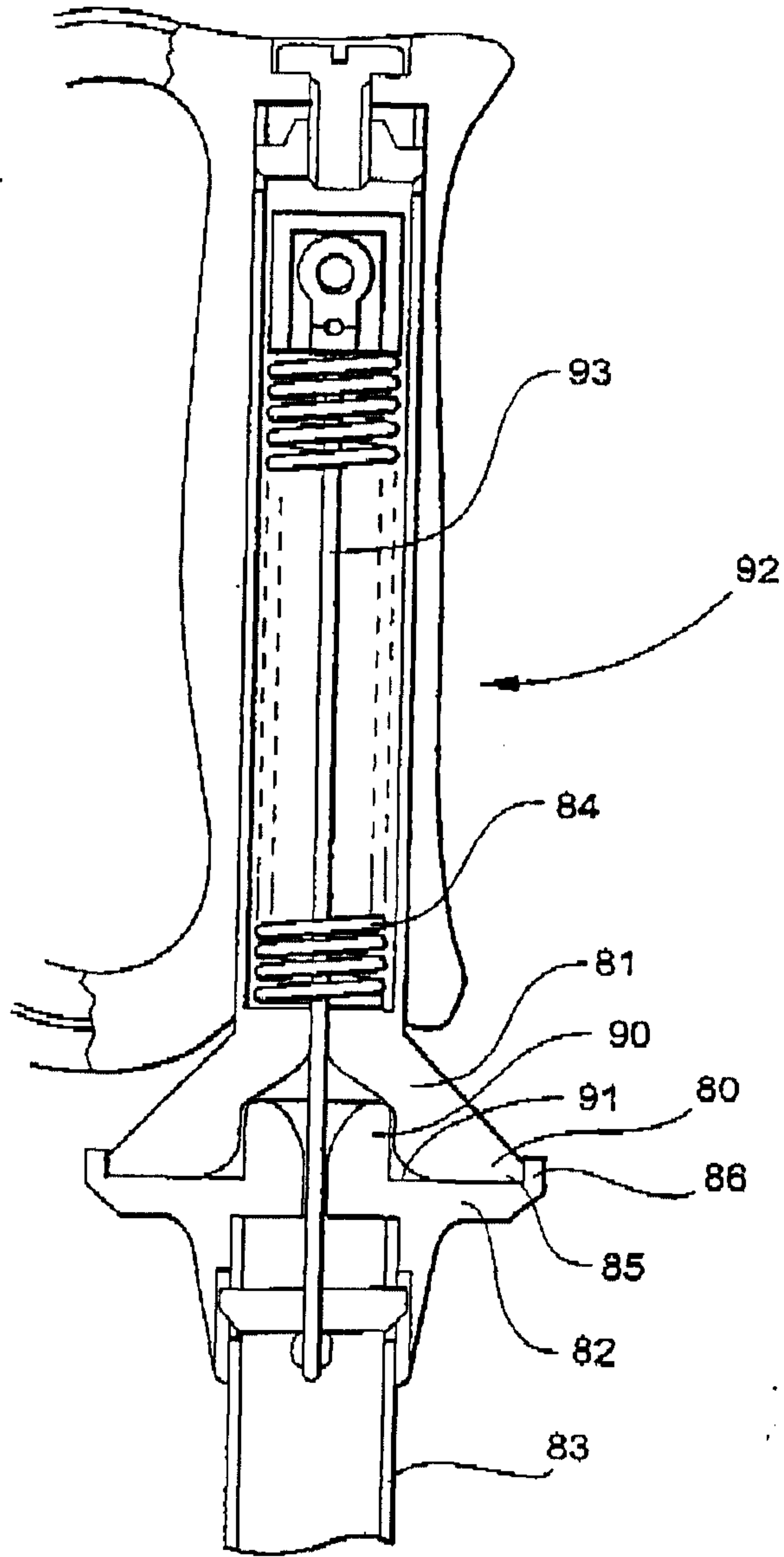

Fig. 11

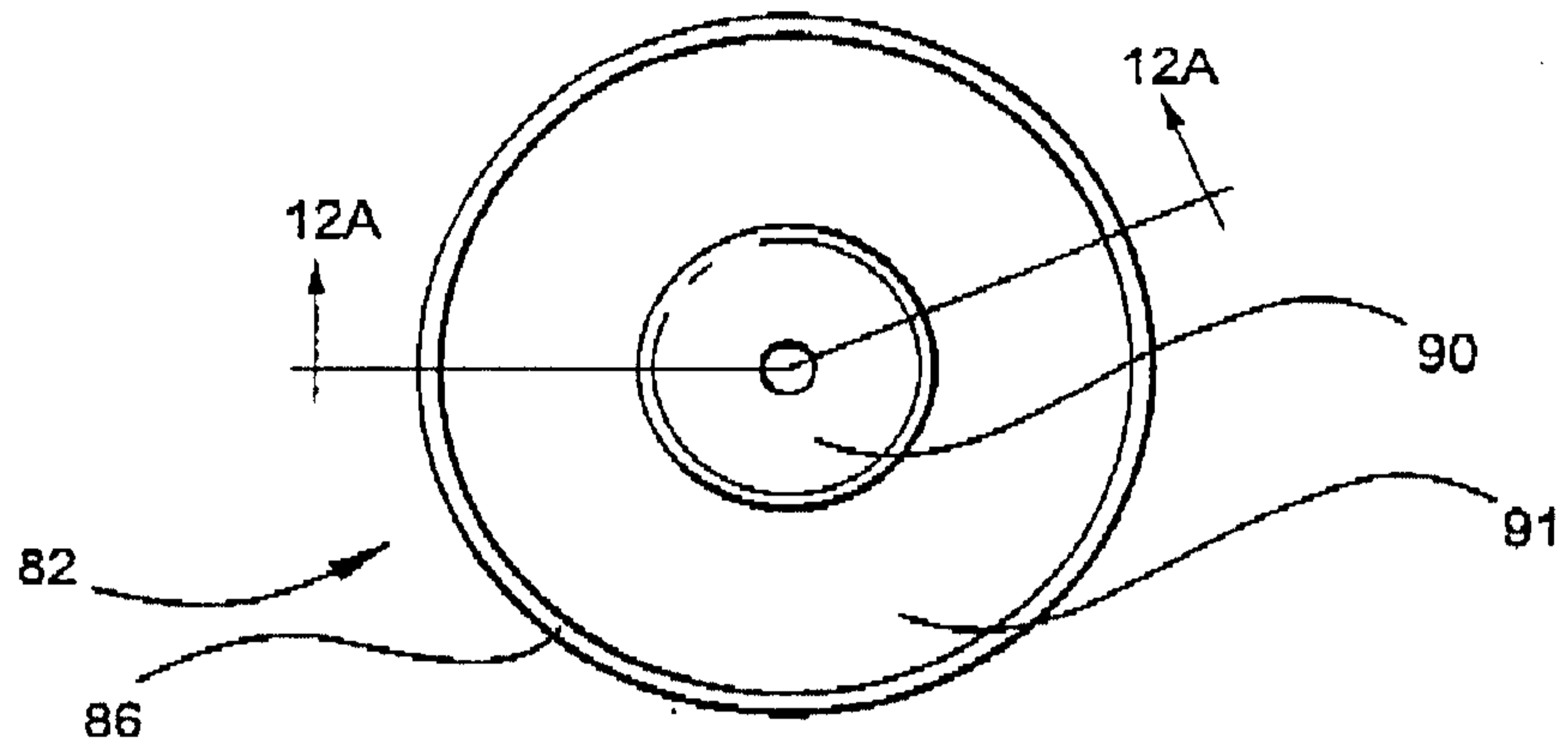
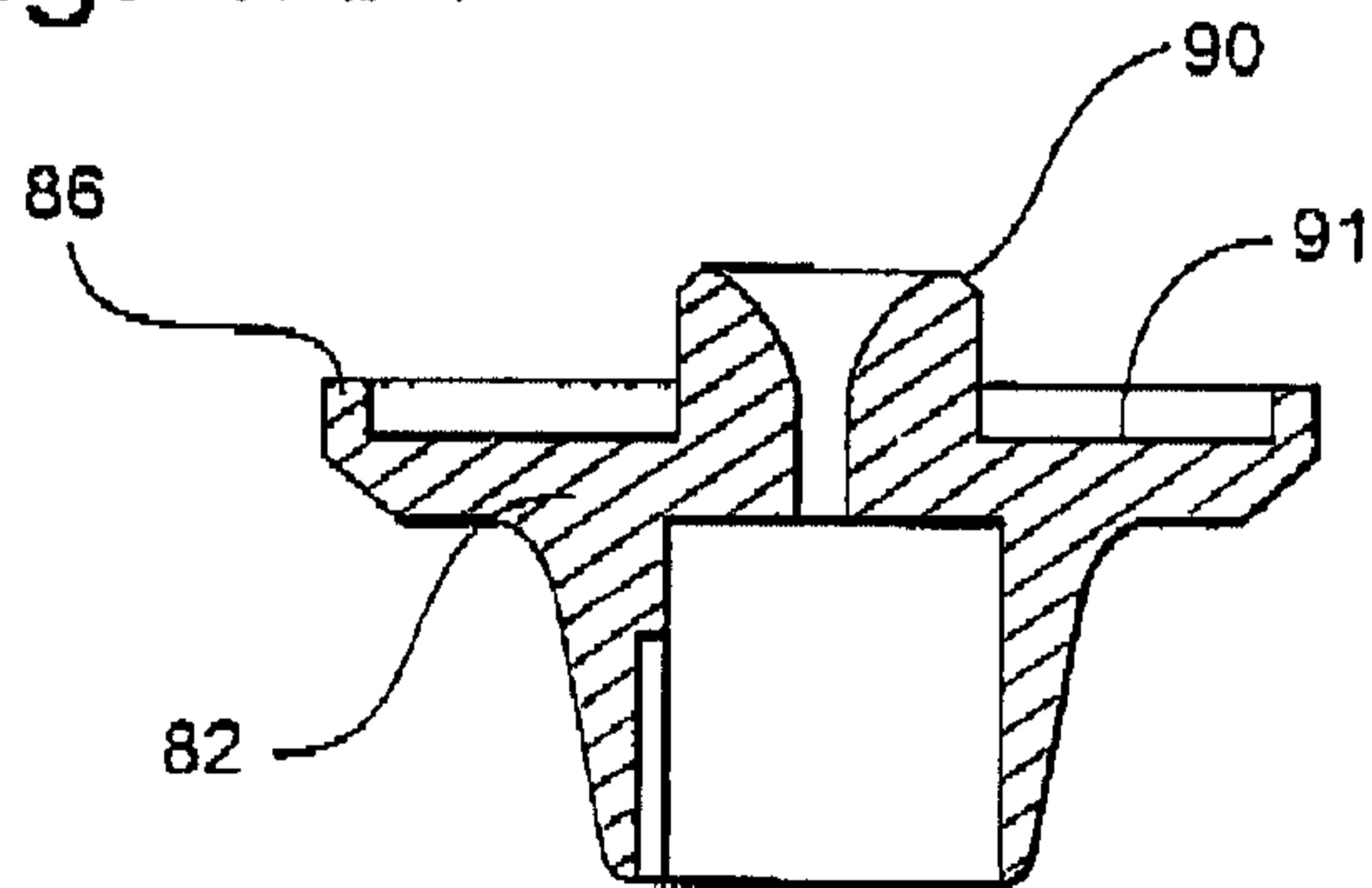

Fig. 12

Fig. 12A



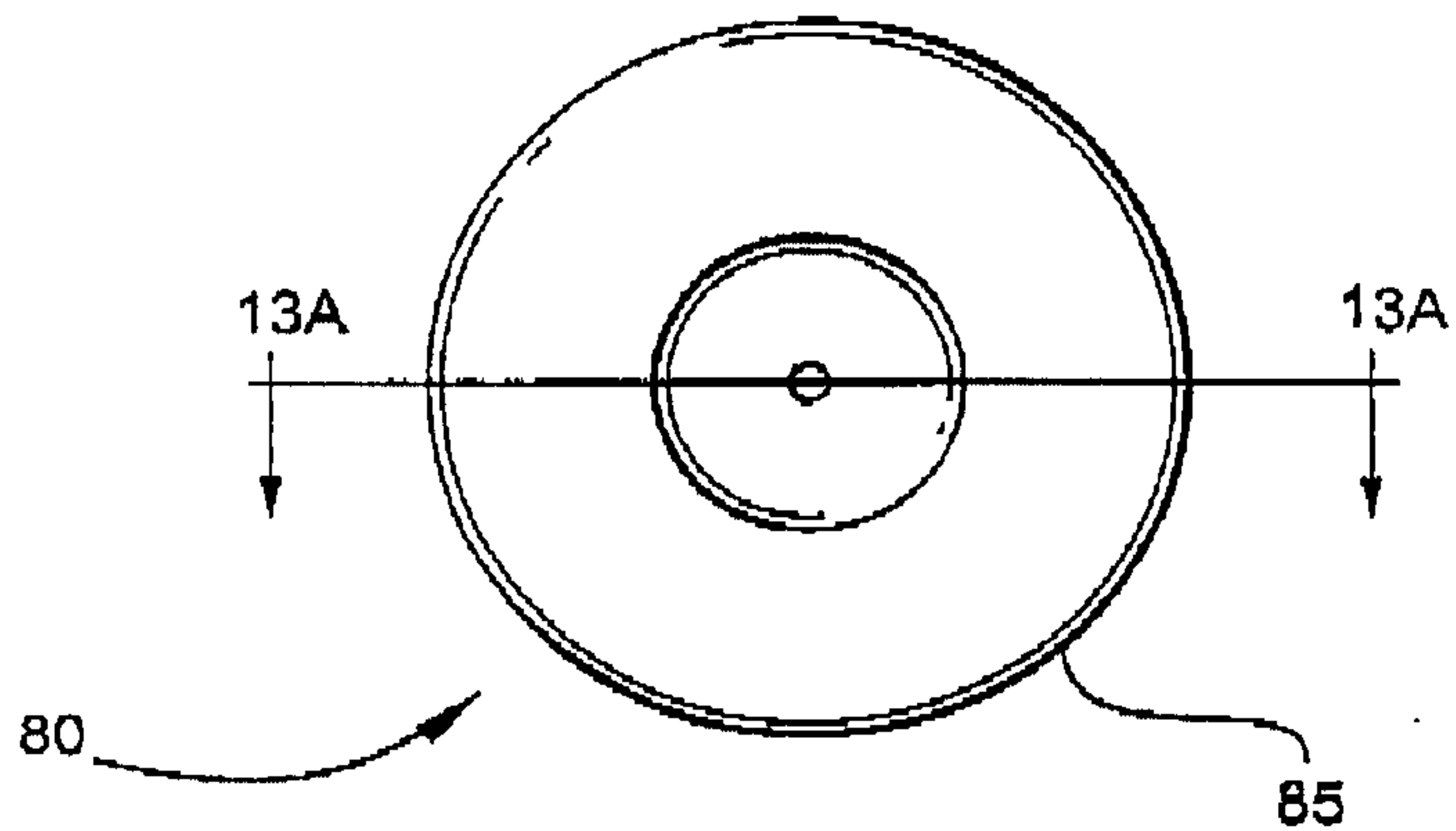

Fig. 13

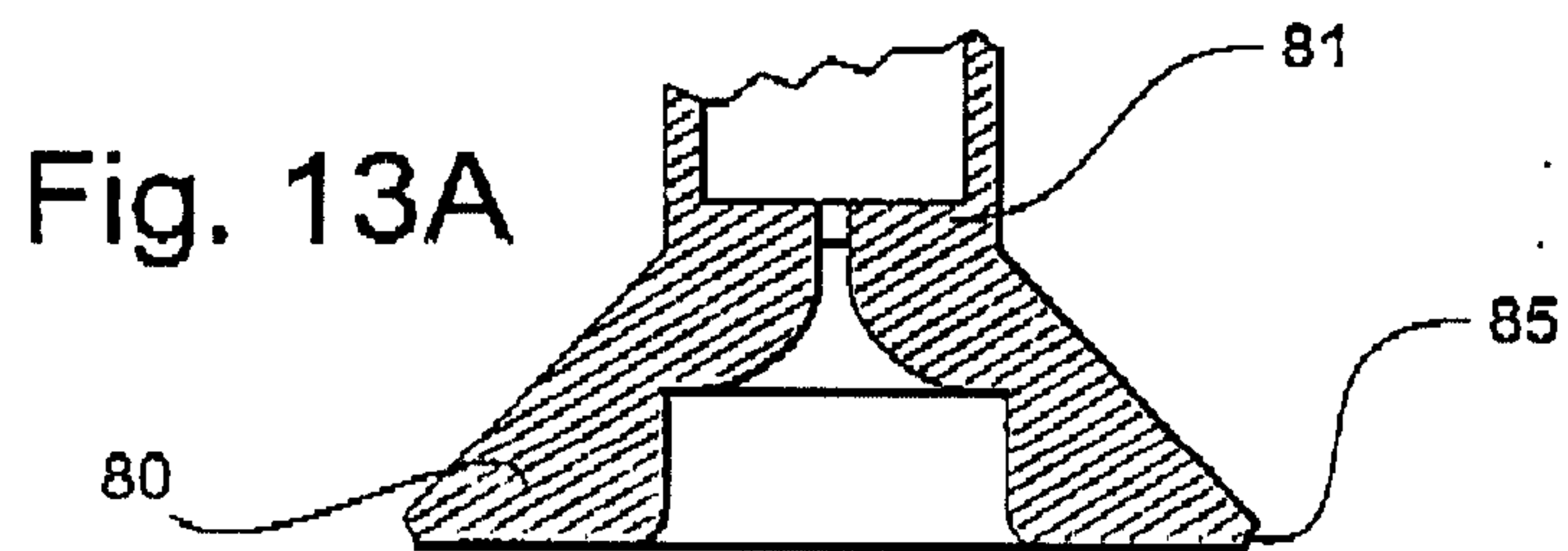

Fig. 13A

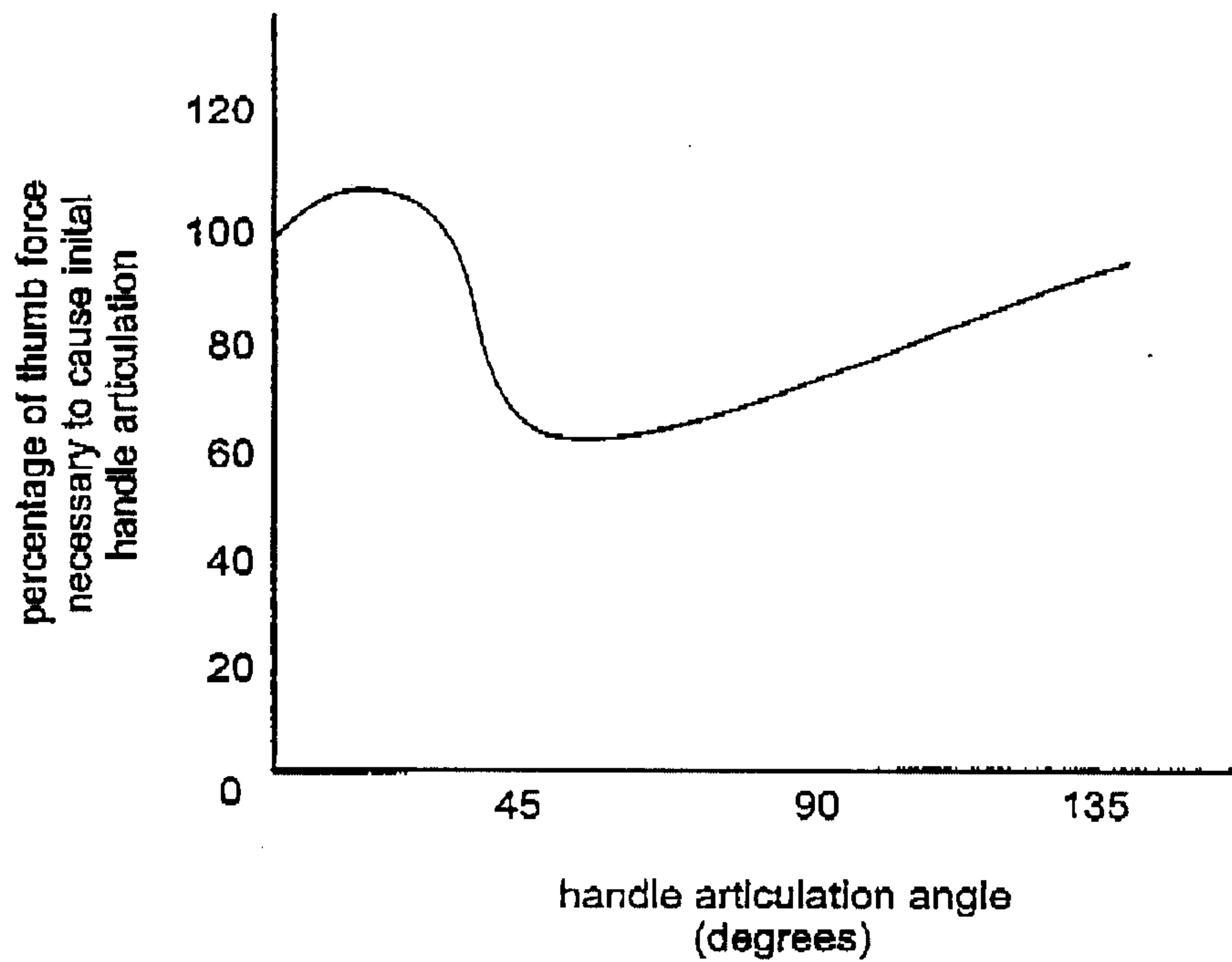

Fig. 14

