

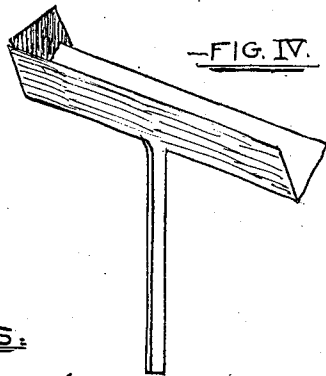

J. KING.

Improvement in Elevators for Building Materials.  
No. 131,008.

Patented Sep. 3, 1872.

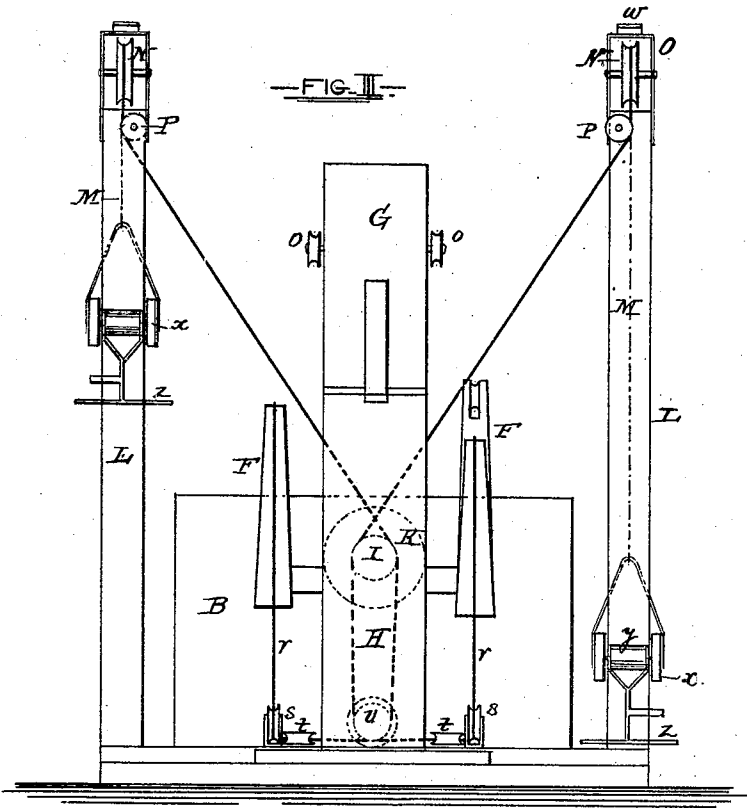

-WITNESSES:

*Geo. H. Norrand.*  
*Dennis Timmy*

-INVENTOR:

*John King*  
*By his attys.*  
*Cox and Cox*

# UNITED STATES PATENT OFFICE.

JOHN KING, OF QUINCY, ILLINOIS.

## IMPROVEMENT IN ELEVATORS FOR BUILDING MATERIALS.

Specification forming part of Letters Patent No. 131,008, dated September 3, 1872.

*To all whom it may concern:*

Be it known that I, JOHN KING, of the city of Quincy, in the county of Adams and State of Illinois, have invented certain new and useful Improvements in Elevators for Building Materials, of which the following is a specification, reference being had to the accompanying drawing.

### *Nature and Objects of the Invention.*

The invention relates to an arrangement of geared wheels, operating ropes passing over pulley-wheels, whereby a reciprocal movement is communicated to lever-arms, the opposite ends of which are provided with a rope passing around pulley-wheels upon the platform of the device, then upward and over a drum, thence to and around pulley-wheels on the upper ends of standards on each side of the platform, the rope being connected with elevator-platforms, which, by the movement of the lever-arms, are alternately elevated and lowered, the standards acting as guides.

The object of the invention is to provide a means of elevating building material, though it is obvious it may be applied to other analogous purposes.

### *Description of the Accompanying Drawing.*

Figure 1 is a side elevation of my invention. Fig. 2 is a plan view of the same. Fig. 3 is an end elevation. Fig. 4 is a view of the platform-hod.

### *General Description.*

A in the accompanying drawing is a crank rigidly secured to the end of a shaft, *a*, which works in bearings in the sides of the box B, one end of the shaft projecting through the front side of the box and being provided with a ratchet-wheel, *b*, the teeth of which are properly engaged by the point of the pawl *c*. The shaft *a* is properly provided with an externally-toothed open gear-wheel, C, the teeth of which engage the teeth of the laterally-toothed wheel D, which should be of greater diameter than the wheel C, and fixedly secured at or about the center of the shaft *d*, which revolves in bearings in the ends of the box B and is properly supported about its center by the inclined braces or bars *e*. Thus the planes of the shafts *a* and *d* intersect each other at right angles. The shaft *d* is properly provided, at points ad-

jacent to its bearings, with the drums E, to which are secured one of the ends of the cords or ropes *f*, which are so arranged upon the drums E that when the same revolve one cord is wound and the other unwound. At a point opposite and below the drums E, the slots *g* are cut in the lower part of the box B, directly across the longitudinal centers of which passes the axle *h*, upon which are provided the grooved pulley-wheels *i j*. The cords *f* pass from the drums E under the pulley-wheels *i*, thence to and over the pulley-wheels *k* in the ends of the arms F, thence over the wheels *j*, thence to the eyes *l* on the opposite and outer sides of the arms F, in which the ends of the cords are secured. Thus the wheels *i j k*, with the cord *f*, operate in the manner of a block and tackle. Midway between the slots *g* the pulley-wheel *l* is so placed that its lateral planes have an inclination of about forty-five degrees, ( $45^{\circ}$ ;) about this wheel passes the cord *n*, which extends over the wheels *o*, which revolve on axles near the upper part of the standard G; thence the cords extend downward and are attached to the eyes *p*, on the inner sides of the ends of the arms F, thus connecting these arms and regulating their alternate movement. The arms F are pivoted at their elbows or angles to the standard G and have a vertical movement. The front and rear parts of the arms are joined at an angle somewhat greater than forty-five degrees, ( $45^{\circ}$ ;) the apex of the angle being below. The rear portion is of one piece of material, while the front may be of one piece, or, as in the present instance, of more pieces, connected by straps *q*, and capable of extension to afford a greater leverage power to the arm, to the rear end of which is secured one end of the cord *r*, which extends downward and under the pulley-wheel *s*, placed in a vertical position on the platform of the device, below the rear end of the arm F, thence about the pulley-wheel *t*, which is adjacent to the wheel *s*, but operating horizontally. From the wheel *t* the cord *r* passes to and over the wheel *v*, on the inside of the standard H, thence upward and around the spool I of the drum K. The cord thence passes down to and about the wheels *v t* and *s* to the end of the other arm F, in a manner corresponding to that already described. By this arrangement the revolution of the drum

K and the reciprocal movement of the arms F are accomplished and assisted. Upon each side of the platform, upon the device opposite to each other, are properly secured the vertical standards L, which are so placed as that their vertical centers are in the same vertical plane as the similar center of the drum K, from which they are equidistant. These standards may be of a single piece of material, or may be jointed or otherwise made capable of extension. Their upper ends are connected by a rod, *w*. The elevator-platform may be of any desired construction suited to the nature of the material to be elevated. In the present instance they consist of notched bars, *x*, properly secured by bolts, those parts of which between the bars *x* operating both as axles upon which the friction-wheels *y* revolve, and also to support the step *z*. The platform is provided with a suitable means of attachment, to which the cord M is secured; thus the standard acts as a guide in raising and lowering the platform, the friction-wheels *y* operating upon opposite sides of the standard, facilitating the ascent and descent. The upper part of the standard is provided with a pulley-wheel, N, revolving in a fixed axle in the cap O, immediately below which, and upon opposite sides of the standards, are placed the pulley-wheels P. One end of the cord M is secured properly to the elevator-platform, thence passes over the wheel N, thence downward and about the wheel P, thence downward and around the drum K, its other end passing similarly over corresponding wheels upon the opposite standard L, and secured to the elevator-platform on the opposite side thereof. Thus by this arrangement of the cord M the elevator-platforms are alternately raised and lowered. The drum K is provided with the spool I, and rigidly secured to the axle R, which works in bearings in the standards G and H, which standards are properly connected by the brace S. The standards L should be of a length equal to the height to which it is desired to elevate the material. Rope or chain may be used in the place of cord.

#### Operation.

One of the elevator-platforms being in its lowest position, the material to be raised is placed thereon. The crank A is now turned, thus causing the drums E to revolve, which winds up one of the cords *f* and unwinds the other; by this movement the front end of one of the arms F is drawn downward, thus raising the rear end of the same and drawing the cord *r* taut on the spool I, thus causing the drum K to revolve and take up the cord M, whereby the elevator-platform on the opposite side of the device is raised as high as desired. As by the operation of elevating one of the platforms those cords which are directly operative in this respect are loosened, hence the opposite elevator-platform descends by its own gravity at the same time as the other is being elevated.

#### Claims.

What I claim as my invention, and desire to secure by Letters Patent, is—

1. The combination and arrangement of the drums E, cords *f*, pulley-wheels *i j k*, and arms F, substantially as and for the uses and purposes shown and described.
2. The wheel *l*, in combination with the cord *n*, wheels *o*, and arms F, substantially as shown and described.
3. The arms F provided with the cords *f* and *r*, arranged and operated as shown and described in combination with the drum K, substantially as and for the uses and purposes shown and set forth.
4. The standards L, pulley-wheels N and P, cord M, drum K, in combination with an elevator-platform, substantially as shown and set forth.

In testimony that I claim the forgoing improvements in elevators for building materials, as above described, I have hereunto set my hand and seal.

JOHN KING. [L. S.]

Witnesses:

P. C. KELLER,  
THOS. T. WOODRUFF.